TITLE:

An example application in support of Optical Link Interface (OLI)

SOURCE:

Sudheer Dharanikota, Raj Jain
Curtis Brownmiller

Nayna Networks Inc.
Worldcom

CONTACT: Raj Jain

**Raj Jain is now at
Washington University in Saint Louis
Jain@cse.wustl.edu
<http://www.cse.wustl.edu/~jain/>**

DATE: January 2002

DISTRIBUTION: T1X1.5

ABSTRACT:

This document considers communication between Photonic Cross Connects (PXC) with Opto-electronic line systems as an application that motivates the need for Optical Link Interface (OLI) or Virtual Backplane Interface (VBI).

Key words: PXC, DWDM, LMP, OLI, VBI, Fault monitoring and Fault reporting

1. Motivation for OLI/VBI

A recent ANSI contribution [1] requested to present the applications that require OLI (Optical Link Interface, [2]) or VBI (Virtual Backplane Interface, [2]). In this document we present an application that motivates such interfaces and then discuss different cases where a protocol supporting OLI or VBI may be useful.

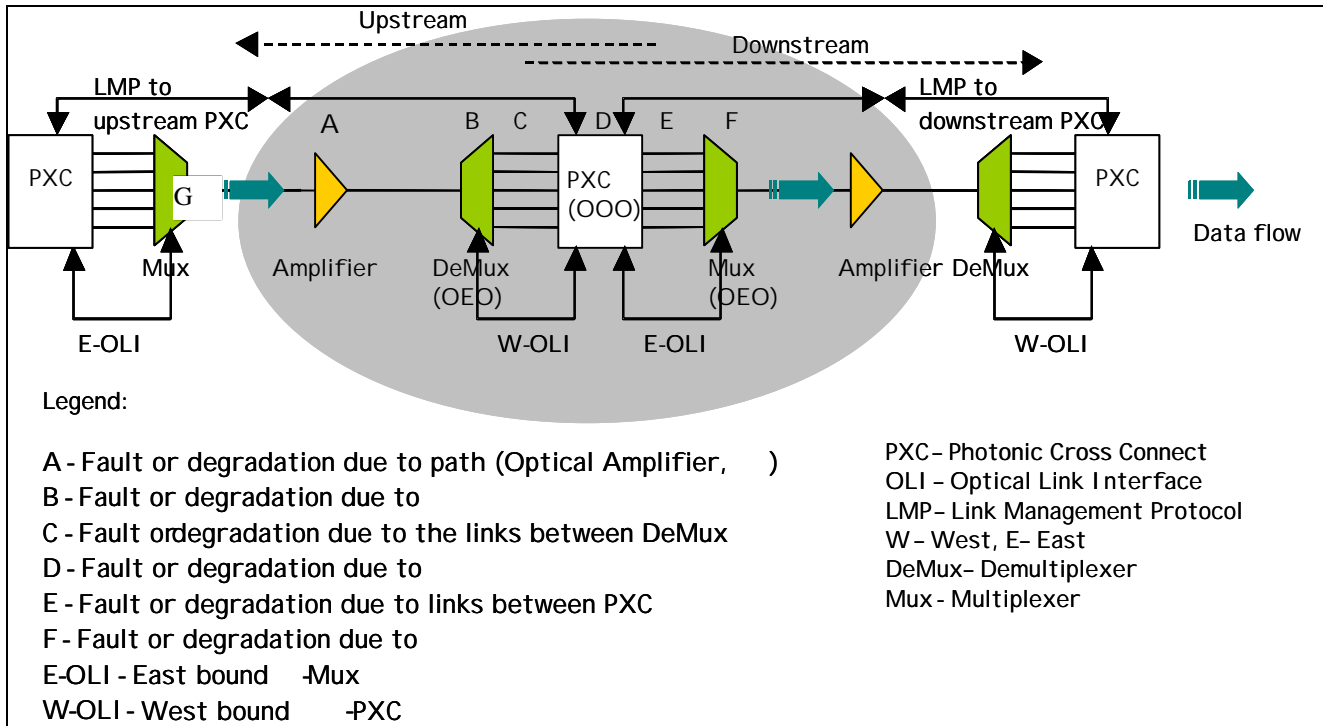

Figure 1 A typical PXC and OEO Line System inter-working scenario with the depiction of different fault conditions

Application:

Figure 1 presents typical optical domain segments that contain Photonic Cross-connects (an all optical device (OOO)), an Opto-electronic line system (typically an OEO DWDM equipment) and other optical devices (e.g., optical amplifiers). Such a scenario is greatly enhanced, when an interface with an OEO device is used to provide fault notification. The addition of this capability will reduce reporting times and thereby improving overall fault restoration times.

Different Cases:

In Figure 1 we present different failure or degradation conditions that can trigger restoration activities of a connection. These faults and degradations are:

- A - Fault or degradation due to path (Optical Amplifier, fiber etc.)
- B - Fault or degradation due to DeMux (De-Multiplexer)
- C - Fault or degradation due to the links between DeMux and PXC
- D - Fault or degradation due to PXC
- E - Fault or degradation due to links between PXC and Mux (Multiplexer)
- F - Fault or degradation due to Mux

Case (i) Upstream electrical faults/degradations that a PXC cannot detect

A PXC cannot detect upstream degradations such as excessive BER (Bit Error Rate) or LOF (Loss Of Frame) that can only be detected in the electrical domain. These degradations could have originated at locations A, B, or G in the above figure. Also upstream failures such as Loss Of Light (LOL) cannot be detected by a PXC if the DeMux generates a downstream SONET or SDH AIS frame. Therefore to monitor and communicate the failures and degradations that are not visible to a PXC, one needs an open interface protocol (W-OLI) between the upstream OEO devices such as DWDM equipment and OOO devices such as PXC's.

Case (ii) Downstream faults/degradations that can be rectified by PXC

Failures or degradations at E or F that can be detected by Mux may be solved by the upstream PXC. If such failures are not communicated to the PXC, it may take longer time to report via LMP (Link Management Protocol, [0]) like protocols. Hence to improve connection restoration times an open interface protocol (E-OLI) between the downstream OEO devices such as DWDM equipment and OOO devices such as PXC's.

Case (iii) Others

A communication between Mux or DeMux with a PXC may provide other benefits such as provisions for non-real time fault analysis, communicating the PXC invisible resource mappings (such as fiber to connection relationship) to the PXC which in turn can be used for better provisioning, and an infrastructure to use for communicating the client layer information to the server layer equipment.

2. Non-Goals

The goal of the example presented here is rapid and reliable notification of failures and to enable fault isolation to a switching point so that a recovery can be initiated. Isolating a failed component is not a goal of the OLI/VBI protocols. Once the existing connections have been recovered, faulty components can be located by off-line diagnostics or test methods.

Although primary applicability of OLI protocols is for all-optical devices, this does not exclude other applications. In the future these same concepts and protocols can be extended for other client-server layers.

3. Conclusions

In this document, we presented an application that could benefit from OLI/VBI related standardizations. Many failure or degradation cases that require such a communication to provide better fault restoration times are discussed.

4. References

1. Sprint, "OLI/VBI Standardization Strategy," ANSI T1X1.5/2002-001.
2. Many Authors, "Optical Link Interface Requirements," ITU-T Q14/15 Rapporteur Meeting, 4-8 June 2001, Turin, Italy, http://ties.itu.int/u/tsg15/sg15/wp3/q14/0106/wd33_uitoli.doc
3. M. Vessers, "Virtual Backplane Interface," ITU-T Q14/15 Rapporteur Meeting, 4-8 June 2001, Turin, Italy.
4. J. P. Lang, et al., "Link Management Protocol (LMP)," IETF working group document, draft-ietf-ccamp-lmp-02.txt, an IETF working group draft.