



**The ATM Forum**  
**Technical Committee**

**Introduction to ATM Forum**  
**Performance Benchmarking**  
**Specifications**

**af-test-00**

**May, 1996**

**Introduction to ATM Forum Performance Benchmarking Specifications**

Version 1.0

May, 1996

(C) 1996 The ATM Forum. All Rights Reserved. No part of this publication may be reproduced in any form or by any means.

The information in this publication is believed to be accurate at its publication date. Such information is subject to change without notice and the ATM Forum is not responsible for any errors. The ATM Forum does not assume any responsibility to update or correct any information in this publication. Notwithstanding anything to the contrary, neither The ATM Forum nor the publisher make any representation or warranty, expressed or implied, concerning the completeness, accuracy, or applicability of any information contained in this publication. No liability of any kind shall be assumed by The ATM Forum or the publisher as a result of reliance upon any information contained in this publication.

The receipt or any use of this document or its contents does not in any way create by implication or otherwise:

- Any express or implied license or right to or under any ATM Forum member company's patent, copyright, trademark or trade secret rights which are or may be associated with the ideas, techniques, concepts or expressions contained herein; nor
- Any warranty or representation that any ATM Forum member companies will announce any product(s) and/or service(s) related thereto, or if such announcements are made, that such announced product(s) and/or service(s) embody any or all of the ideas, technologies, or concepts contained herein; nor
- Any form of relationship between any ATM Forum member companies and the recipient or user of this document.

Implementation or use of specific ATM recommendations and/or specifications or recommendations of the ATM Forum or any committee of the ATM Forum will be voluntary, and no company shall agree or be obliged to implement them by virtue of participation in the ATM Forum.

The ATM Forum is a non-profit international organization accelerating industry cooperation on ATM technology. The ATM Forum does not, expressly or otherwise, endorse or promote any specific products or services.

## Table of Contents

1.	Introduction.....	1
1.1	Scope.....	1
1.2	Goals of Benchmarking.....	1
1.3	Non Goals of Benchmarking.....	2
1.4	Structure of Document.....	2
1.5	Terminology.....	2
1.6	Abbreviations.....	3
2.	Objectives of Performance Testing.....	3
3.	Classes of Applications.....	4
3.1.	Performance Testing Above the ATM Layer.....	5
3.2.	Performance Testing at the ATM Layer.....	5
4.	Performance Testing.....	7
A	Out-of service Measurement of QoS Parameters	
A.1	Test Configuration.....	8
A.1.1	Test Cell Input.....	10
A.1.2	Test Cell Output.....	10
A.2	Analyzing of the test cell stream.....	12
A.2.1	Cell error ratio (CER).....	12
A.2.2	Cell loss ratio (CLR).....	12
A.2.3	Cell misinsertion rate (CMR).....	13
A.2.4	Cell missequenced ratio (CSR).....	13
A.3	Measuring two-point cell delay and cell delay variation.....	14
A.3.1	Mean cell transfer delay.....	14
A.3.2	Maximum cell transfer delay.....	15
A.3.3	Peak-to-peak two-point cell delay variation.....	15
A.4	Measuring one-point cell delay variaiton.....	15
A.4.1	Maximum one-point cell delay variation.....	15
A.5	Test cell format.....	16
A.5.1	Sequence Number.....	16
A.5.2	Time Stamp 1.....	16
A.5.3	Time Stamp 2.....	17
A.5.4	Reserved.....	17
A.5.5	Scrambling Indicator.....	17
A.5.6	Test Cell Version.....	17
A.5.7	Payload Type.....	17
A.5.8	Unused.....	17
A.6	Algorithms.....	17
A.6.1	Gaining Synchronization to Sequence Number.....	18
A.6.2	Determining the presence of Scrambling.....	18
A.6.3	Detecting and Accumulating Errored Cells.....	18

A 6.4 Detecting Lost, Out-of-Sequence and Misinserted Cells ..... 19

B 1 Measurement of QoS Parameters using OAM Flow ..... 19

B 2 Overview of performance management OAM ..... 19

B 3 Out-of-service use of performance management OAM..... 19

B 4 Benefits of performance management OAM technique ..... 20

B 5 ATM Test Cell ..... 21

5. Status and Conclusion ..... 21

## 1. Introduction

Performance testing in ATM deals with the measurement of the level of quality of a SUT or a IUT under well-known conditions. The level of quality can be expressed in the form of metrics such as latency, end-to-end delay, effective throughput. Performance testing can be carried at the end-user application level (e.g., ftp, nfs) or at or above the ATM layers (e.g., cell switching, signaling, etc.). Performance testing also describes in details the procedures for testing the IUTs in the form of test suites. These procedures are intended to test the SUT or IUT and should not assume or imply any specific implementation or architecture of these systems.

This document contains a proposal for a baseline document for performance testing. It highlights the objectives of performance testing and suggests an approach for the development of the test suites.

Performance testing has been referred to as "performance benchmarking" in other contributions presented at the ATM Forum. For consistency with reference [1], it is recommended to use the terminology "performance testing" instead.

### 1.1 Scope

Performance benchmarking is related to user perceived performance of ATM technology. For the success of ATM technology, it is important that the performance of existing and new applications be better than that on other competing networking technologies. In other words, goodness of ATM will not be measured by cell level performance but by frame-level performance and performance perceived at higher layers.

Most of the quality of Service (QoS) metrics, such as cell transfer delay (CTD), cell delay variation (CDV), cell loss ratio (CLR), and so on, may or may not be reflected directly in the performance perceived by the user. For example, while comparing two switches if one gives a CLR of 0.1% and a frame loss ratio of 0.1% while the other gives a CLR 1% but a frame loss of 0.05%, the second switch will be considered superior by many users,

ATM Forum and ITU have standardized the definitions of QoS metrics. We need to do the same for higher level performance metrics. Without a standard definition, each vendor will use their own definition of common metrics such as throughput and latency resulting in a confusion in the market place. Avoiding such a confusion will help buyers eventually leading to better sales resulting in the success of the ATM technology.

## 1.2 Goals of Benchmarking

The goal of this effort is to enhance the marketability of ATM technology and equipment. Any additional criteria that helps in achieving that goal can be added later to this list.

a. The ATM Forum shall define metrics that will help compare various ATM equipment in terms of performance.

b. The metrics shall be such that they are independent of switch or NIC architecture.

1. The same metrics shall apply to all architectures.

c. The metrics can be used to help predict the performance of an application or to design a network configuration to meet specific performance objectives.

d. The ATM Forum will develop a precise methodology for measuring these metrics.

1. The methodology will include a set of configurations and traffic patterns that will allow vendors as well as users to conduct their own measurements.

e. The benchmarking shall cover all classes of service including CBR, VBRRT, VBRNRT, ABR, and UBR.

f. The metrics and methodology for different service classes may be different.

g. The benchmarking shall cover as many protocol stacks and ATM services as possible.

1. As an example, benchmarks for verifying the performance of services such as IP, Frame Relay and SMDS over ATM may be included.

h. The benchmarking shall include metrics to measure performance of network management, connection setup, and normal data transfer.

## 1.3 Non-Goals of Benchmarking

a. The ATM Forum is not responsible for conducting any measurements.

b. The ATM Forum will not certify measurements.

c. The ATM Forum will not set thresholds such that equipment performing below those thresholds are called "unsatisfactory."

d. The ATM Forum shall not establish any requirement that dictates a cost versus performance ratio.

## 1.4 Structure of Document

This document is structured as follows:

- Section 1 constitutes the introduction. It describes the scope, goals and non-goals of the ATM Forum. The structure of the document and the terminology are listed.
- Section 2 provides the objective of Performance Testing.
- Section 3 explains the classes of applications. Performance testing is divided into measurement above the ATM Layer which includes AAL5 layer and the higher layers and at the ATM Layer.
- Section 4 describes the Living List.
- Section 5 gives the conclusion.

## 1.5 Terminology

The following definitions are used in this document. Some of the definitions are taken wholly or partly from [1].

\*Implementation Under Test (IUT): The part of the system that is to be tested.

\*Metric: a variable or a function that can be measured or evaluated and which reflects quantitatively the response or the behavior of an IUT or an SUT.

\*System Under Test (SUT): The system in which the IUT resides.

\*Test Case: A series of test steps needed to put an IUT into a given state to observe and describe its behavior.

\*Test Suite: A complete set of test cases, possibly combined into nested test groups, that is necessary to perform testing for an IUT or a protocol within an IUT.

## 1.6 Abbreviations

ISO	International Organization for Standardization
IUT	Implementation Under Test
NP	Network Performance
NPC	Network Parameter Control
PDU	Protocol Data Unit

PVC	Permanent Virtual Circuit
QoS	Quality of Service
SUT	System Under Test
SWG	Sub Working Group
SVC	Switched Virtual Circuit

## 2. Objectives of Performance Testing

Asynchronous Transfer Mode, as an enabling technology for the integration of services, is gaining an increasing interest and popularity. ATM networks are being progressively deployed and in most cases a smooth migration to ATM is prescribed. This means that most of the existing applications can still operate over ATM via service emulation or service interworking along with the proper adaptation of data formats. At the same time, several new applications are being developed to take full advantage of the capabilities of the ATM technology through an Application Protocol Interface (API).

While ATM provides an elegant solution to the integration of services and allows for high levels of scalability, the performance of a given application may vary substantially with the IUT or the SUT utilized. The variation in the performance is due to the complexity of the dynamic interaction between the different layers. For example, an application running with TCP/IP stacks will yield different levels of performance depending on the interaction of the TCP window flow control mechanism and the ATM network congestion control mechanism used. Hence, the following points and recommendations are made. First, ATM adopters need guidelines on the measurement of the performance of user applications under different SUTs. Second, some functions above the ATM layer, e.g., adaptation, signaling, constitute applications (i.e. IUTs) and as such should be considered for performance testing. Also, it is essential that these layers be implemented in compliance with the ATM Forum specifications. Third, performance testing can be executed at the ATM layer in relation to the QoS provided by the different service categories. Finally, because of the extensive list of available applications it is preferable to group applications in generic classes. Each class of applications requires different testing environment such as metrics, test suites and traffic test patterns. It is noted that the same application, e.g., ftp, can yield different performance results depending on the underlying layers used (TCP/IP to ATM versus TCP/IP to MAC layer to ATM). Thus performance results should be compared based on the utilization of the same protocol stack.

The following objectives are set for ATM performance testing:

- (I) Definition of criteria to be used to distinguish classes of applications. Example of criteria are given in Section 4.
- (ii) Definition of classes of applications, at or above the ATM Layer, for which performance metrics are to be provided.



- (iii) Identification of the functions at or above the ATM Layer which influence the perceived performance of a given class of applications. Example of such functions include traffic shaping, quality of service, adaptation, etc. These functions need to be measured in order to assess the performance of the applications within that class.
- (iv) Definition of common performance metrics for the assessment of the performance of all applications within a class. The metrics should reflect the effect of the functions identified in (iii).
- (v) Provision of detailed test cases for the measurement of the defined performance metrics.

The following areas are excluded from the scope of ATM performance testing:

- (I) Applications which performance cannot be assessed by common implementation independent metrics. In this case the performance is tightly related to the implementation. An example of such applications is network management which performance behavior depends on whether it is a centralized or a distributed implementation.
- (ii) Performance metrics which depend on the type of implementation or architecture of the SUT or the IUT.
- (iii) Test configurations and methodologies which assume or imply a specific implementation or architecture of the SUT or the IUT.
- (iv) Evaluation or assessment of results obtained by companies or other bodies.
- (v) Certification of conducted measurements or of bodies conducting the measurements.

### 3. Classes of Applications

Developing a test suite for each existing and new application can prove to be a difficult task. Instead, applications should be grouped into categories or classes. Applications in a given class have similar performance requirements and can be characterized by common performance metrics. This way, the defined performance metrics and test suites will be valid for a range of applications. Classes of applications can be defined based on one or a combination of criteria. The following criteria can be used in the definition of the classes:

- (i) Time or delay requirements: real-time versus non real-time applications.
- (ii) Distance requirements: LAN versus WAN applications.
- (iii) Media type: voice, video, data, or multimedia application.

- (iv) Quality level: for example desktop video versus broadcast quality video.
- (v) ATM service category used: some applications have stringent performance requirements and can only run over a given service category. Others can run on several service categories. An ATM service category relates application aspects to network functionalities. Examples of user applications for the defined service categories in UNI 4.0 are given in [2].
- (vi) Others to be determined.

### 3.1 Performance Testing Above the ATM Layer

Performance metrics can be measured at the user application layer, and sometimes at the transport layer and the network layer, and can give an accurate assessment of the perceived performance. Since it is difficult to cover all the existing applications and all the possible combinations of applications and underlying protocol stacks, it is desirable to classify the applications into classes as described in section 4. Performance metrics and performance test suites can be provided for each class of applications.

The perceived performance of a user application running over an ATM network is dependent on many parameters. It can vary substantially by changing an underlying protocol stack, the ATM service category it uses, the congestion control mechanism used in the ATM network, etc. Furthermore, there is no direct and unique relationship between the ATM Layer Quality of Service (QoS) parameters and the perceived application performance. For example, in an ATM network implementing a packet level discard congestion mechanism, applications using TCP as the transport protocol may see their effective throughput improved while the measured cell loss ratio may be relatively high. In practice, it is difficult to carry measurements in all the layers that span the region between the ATM Layer and the user application layer given the inaccessibility of testing points. More effort needs to be invested to define the performance at these layers. These layers include adaptation, signaling, etc.

### 3.2 Performance Testing at the ATM Layer

The notion of application at the ATM Layer is related to the service categories provided by the ATM service architecture. The Traffic Management Specification, version 4.0, specifies five service categories [2]: CBR, rt-VBR, nrt-VBR, UBR, and ABR. Each service category defines a relation of the traffic characteristics and the Quality of Service (QoS) requirements to network behavior. A set of ATM QoS parameters is defined in [2]. There is an assessment criteria of the QoS associated with each of these parameters. These are summarized in Table 6.1.

QoS PERFORMANCE PARAMETER	QoS ASSESSMENT CRITERIA
Cell Error Ratio	Accuracy
Severely-Errored Cell Block Ratio	Accuracy
Cell Misinsertion Rate	Accuracy
Cell Loss Rate	Dependability
Cell Transfer Delay	Speed
Cell Delay Variation	Speed

Table 6.1: ATM Transfer Performance Parameters.

A few methods for the measurement of the QoS parameters are defined in [2]. However, detailed test cases and procedures, as well as test configurations are needed for both in-service and out-of-service measurement of QoS parameters. An example of test configuration for the out-of-service measurement of QoS parameters is given in [1].

Performance testing at the ATM Layer covers the following categories:

- (i) In-service and out-of-service measurement of the QoS performance parameters for all five service categories (or application classes in the context of performance testing): CBR, rt-VBR, nrt-VBR, UBR, and ABR. The test configurations assume a non-overloaded SUT.
- (ii) Performance of the SUT under overload conditions. In this case, the efficiency of the congestion avoidance and congestion control mechanisms of the SUT are tested.

In order to provide common performance metrics that are applicable to a wide range of SUT's and that can be uniquely interpreted, the following requirements must be satisfied:

- (i) Reference load models for the five service categories CBR, rt-VBR, nrt-VBR, UBR, and ABR, are required. Reference load models are to be defined by the Traffic Management Working Group.
- (ii) Test cases and configurations must not assume or imply any specific implementation or architecture of the SUT.

## 4. Performance Testing

This *Living List* is intended as a means to capture text from contributions dealing with in-service and out-of-service measurement of QoS parameters. The current contents of the list come from contributions atmf 95-1306 (TTC), atmf 95-1576 (HP), atmf 95-1577 (HP) and the Test SWG document af-test-0022. Text in the Living List will be modified by contributions to the Test SWG until the text is either approved for inclusion in a new ATM Network Transmission Performance Testing document or is deleted.

Performance testing consists of measuring QoS or NP parameters that are traffic dependent under well-known traffic conditions (load and profile).

Performance testing falls into two categories of tests:

- \* Measurement of QoS or NP parameters: QoS or NP parameters must not exceed a certain level under "normal load" condition. "Normal load" condition is for example, for the ATM layer: Cell traffic load compliant to the traffic contract; for SVC connections: Signalling traffic less than a certain specified level.

- \* Overload Testing: The SUT has some overload defense mechanism implemented which should be tested.

Examples

- \* UPC (usage parameter control) or NPC (network parameter control) at the ATM layer;
- \* Call/Connection rejection at the signalling level.

In general, performance testing involves two kinds of test equipment: a Generator and an Analyzer, which can be built in a single piece of the test equipment. A generic test configuration is shown in Figure 5.1. The Generator generates different patterns of traffic (cell traffic to test PVC or calls to test SVC connections) while the Analyzer measures such performance parameters as: cell error ratio, cell transfer delay, cell delay variation, etc.

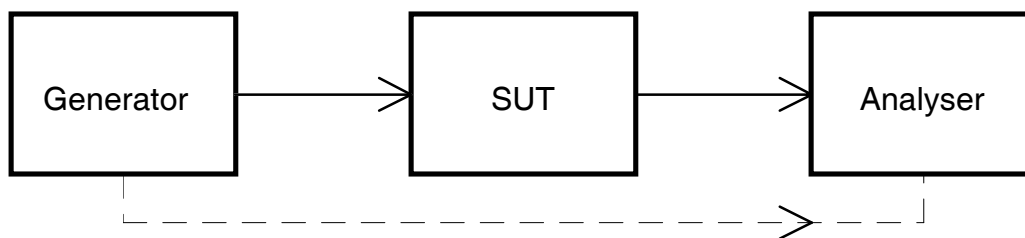

Figure 5.1: Generic Test Configuration for Performance Testing

## A. Out-of-service Measurement of QoS Parameters

### A.1 Test Configuration

Since QoS parameters are defined as parameters that can directly be observed by the users, the following definitions can be given:

- \* System under Test (SUT) is an ATM network or an ATM switch;
- \* Access for QoS measurement is the T or S reference point at the UNI.

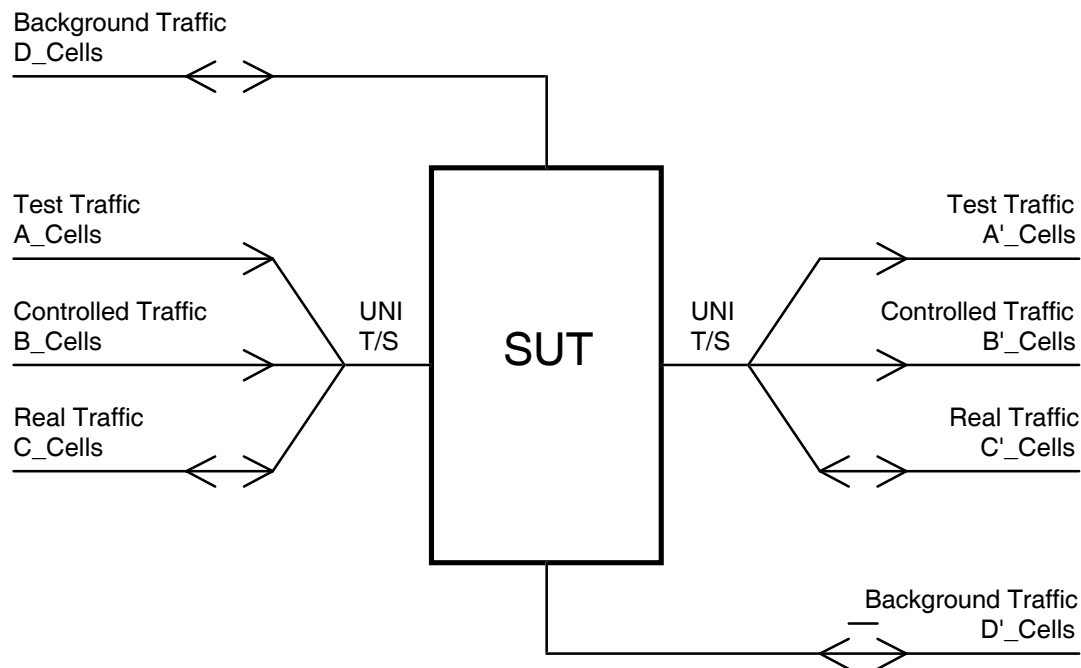

Figure A.1: QoS Measurement Arrangement

The SUT is loaded by the following cell traffic:

- \* Traffic at the Test Cell Input:
  - \* Test Traffic (A\_Cells, unidirectional, called test cell stream) generated by the test equipment for the VP and/or VC used for testing purposes;

- \* Controlled Traffic (B\_Cells, unidirectional) generated by the test equipment but for VPs/VCs not used for testing;
  - \* Real Traffic (C\_Cells, bi-directional) generated/terminated by real subscribers connected to the UNI used for testing.
- \* Traffic at the Test Cell Output:
- \* Test Traffic (A'\_Cells, unidirectional) terminated at the test equipment for the VP and/or VC used for testing purposes;
  - \* Controlled Traffic (B'\_Cells, unidirectional) terminated at the test equipment but for VPs/VCs not used for testing;
  - \* Real Traffic (C'\_Cells, bi-directional) generated/terminated by real subscribers connected to the UNI used for testing.
- \* Background Traffic (D\_Cells and D'\_Cells, bi-directional):
- \* Traffic generated by real subscribers not connected at the Test Cell Input or Test Cell Output.

In general two types of test configurations exist:

1. SUT is fully under control by the tester. There is no real and no background traffic. Test traffic as well as the controlled traffic is generated by the test equipment. This configuration will allow reproducible test results to be obtained because the QoS parameters very much depend on the overall traffic in the SUT.

2. SUT is loaded with real as well as background traffic that is out of control of the tester. It is difficult to get reproducible test results mainly because the real and background traffic could lead to some overload conditions within the SUT. Therefore it is necessary to measure not only the QoS parameters but in parallel the load:

- \* at the UNI of the Test Cell Input;
- \* at the UNI of the Test Cell Output;
- \* within the SUT

### **A.1.1 Test Cell Input**

The Test Cell Input is a T or S reference point. Two categories of cells can be generated:

A\_Cells that form the test traffic. Each cell contains:

- \* VPI or VCI of a VP resp. VC established for testing purposes.

- \* Correct header (HEC)
- \* Cell payload containing an identification (e.g. a cell sequence number, a time stamp).
- \* Payload has to be guarded by a CRC. Form of the CRC for further study.

Test traffic conforms to the negotiated traffic contract. It should be noted that any non-conformity could introduce cell loss and therefore a significant decrease of the QoS.

B\_Cells which form controlled traffic. Each cell contains:

- \* VPI or VCI different from VP resp. VC used for testing purposes.
- \* Correct header (HEC)
- \* Cell payload: for further study.

### A.1.2 Test Cell Output

The Test Cell Output is a T or S reference point. Since the QoS parameters are based on events of cells, therefore actual measurements can only be performed above the physical layer.

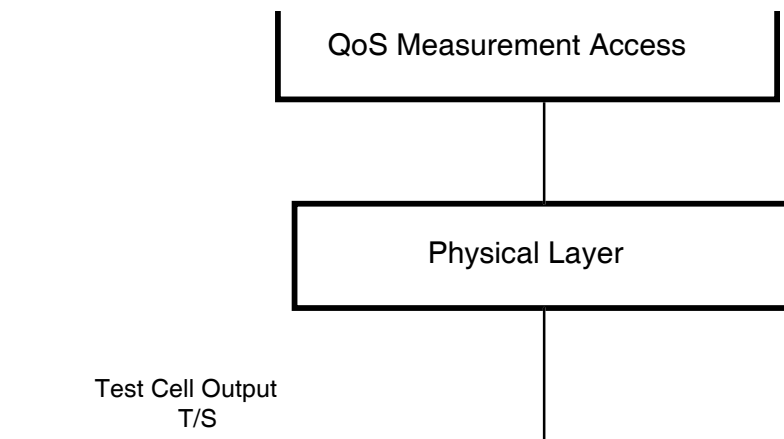

Figure A.2: QoS Measurement Access

The physical layer implemented in the test equipment may be considered as free of processing errors and without processing delay; or errors and delays in the physical layer should be taken into account in the calculation of the QoS parameter values.

QoS measurement access will get only valid cells from the physical layer because cells with a faulty HEC arriving at the Test Cell Output will get the header corrected or will be discarded. Therefore it will not be possible to analyze faulty cells with a HEC error in the ATM layer.

At the QoS measurement access the cell stream will be divided into the following two types of cells:

A'\_Cells belong to the test traffic identified by the VPI and/or VCI.

The following analysis will be done:

\* CRC of the payload:

\* If CRC is correct, the cell is assumed to be a valid test cell. In this case it is possible to analyze the cell identification in the payload. It shows that the cell is in the right sequence:

--- If yes, the cell is assumed to be a correct test cell (called a\_cells).

--- If no, the cell is assumed to be a missequenced test cell (called b\_cells).

\* If CRC is incorrect, the cell is assumed to be an errored test cell even if there is a possibility that the cell is a misinserted one (called c\_cells).

B'\_Cells do not belong to the test traffic but have to be taken into account (together with the real traffic) to calculate the total traffic at the Test Cell Output.

## A.2 Analyzing of the test cell stream

### A.2.1 Cell error ratio (CER)

A continuous test cell stream containing A\_cells is sent at the Test Cell Input. At the Test Cell Output the A'\_cells are analyzed during a time interval of t1 (service dependent, the value is for further study). CER is calculated as follows:

$CER = c / A'$  where

A': number of A'\_cells (received test cells)

c: number of errored A'\_cells (c\_cells: payload CRC is faulty)



This method will lead to incorrect results if misinserted cells with payload bit errors are received (overcount of c and A').

### A.2.2 Cell loss ratio (CLR)

A continuous test cell stream containing A\_cells is sent at the Test Cell Input. At the Test Cell Output the A'\_cells are analyzed during a time interval of t1 (service dependent, the value is for further study). CLR is calculated as follows:

$$\text{CLR} = (A - A') / A \text{ where}$$

A: number of sent A\_cells (test cells)

A': number of received A'\_cells (test cells)

This method will lead to incorrect results if misinserted cells with payload bit errors are received (overcount of A'). In case of misinserted cells > cell loss CLR will be negative.

### A.2.3 Cell misinsertion rate (CMR)

A continuous test cell stream containing only B\_cells is sent at the Test Cell Input. At the Test Cell Output no A'\_cells should arrive otherwise they are misinserted. Therefore A'\_cells are counted during a time interval of t2 (service dependent, the value is for further study). CMR is calculated as follows:

$$\text{CMR} = A' / t2 \text{ where}$$

A': number of received A'\_cells (test cells)

### A.2.4 Cell missequenced ratio (CSR)

I.356 doesn't define a cell missequenced ratio (CSR) because AAL controls missequencing of cells. Nevertheless missequencing of cells is a faulty behavior of the ATM network that can be observed by the user. Therefore an appropriate measuring method is recommended.

A continuous test cell stream containing A\_cells is sent at the Test Cell Input. At the Test Cell Output the A'\_cells are analyzed during a time interval of t1 (service dependent, the value is for further study). CSR is calculated as follows:

$$\text{CSR} = b / A' \text{ where}$$

A': number of received A'\_cells (test cells)

b: number of b\_cells where the cell identification in the payload shows that the cell was overtaken by the previous cell (cell sequence error).

Example:

Cell number:	1	3	4	2	5
Counter value b:	n	n	n	n+1	n+1

Text from ATMF 95-1577 (HP):

### A.3 Measuring two-point cell delay and cell delay variation

To perform Two-point Cell Delay and Cell Delay Variation (CDV) measurements, a timestamp must be used to transmit the time at which each cell is generated. The timestamp generator and receiver must be synchronised for measurements to be made. The timestamps must be synchronized in both frequency and absolute value to allow delay measurements to be made. This may only be practical in a round-trip situation. If the timestamps are only synchronized in frequency (with an unknown offset) it may still be possible to perform CDV measurements.

A timestamp is encoded into the ATM test cell or the performance management OAM cell. When using ATM Test Cells only correct A'\_cells (a\_cells and b\_cells: no payload CRC fault) are analyzed. When using Performance Management OAM cells only the OAM cells (having a correct CRC-10) associated with the A'\_cell stream are analyzed.

All of the two-point CDV parameters are evaluated from the measurement of the Cell Transfer Delay (CTD):

$$CTD = t_r - t_s \text{ where}$$

$t_r$ : receive time relative to the synchronized time reference when the cell reached the Test Cell Output side.

$t_s$ : transmit time relative to the synchronized time reference when the cell left the Test Cell Input side.

Note: CTD is one of the cell transfer performance parameters. It very much depends on the cell traffic in the test traffic, the controlled traffic and the real traffic as such, as well as on the background traffic.

#### A.3.1 Mean cell transfer delay.

Mean cell transfer delay is the arithmetic average (mean) of the CTD measured over the time period  $t_1$  (service dependent, the value is for further study).

$$MCTD(t_1) = S_{cdt} / a \text{ where}$$

a: number of received and correct A'\_cells.

Scdt: Summation of the CDT ( $t_r - t_s$ ) of all correct A'\_cells.

### A.3.2 Maximum cell transfer delay.

Maximum cell transfer delay is the maximum value of the CTD measured over the time period  $t_1$  of all correct A'\_cells.

### A.3.3 Peak-to-peak two-point cell delay variation.

Peak-to-peak two-point cell delay variation is the maximum value of the CTD minus the minimum value of the CTD measured over the time period  $t_1$  of all correct A'\_cells.

## A.4 Measuring one-point cell delay variation

To perform one-point cell delay variation measurements, the arrival time of cells is analyzed according to the Generic Cell Rate Algorithm (GCRA) (ref 3). Any received A'\_cells are used to compute one-point CDV. These may contain test cells or live user data cells. No timestamp needs to be encoded in the transmit data. As a result, the one-point CDV may be performed either in-service or out-of-service.

Equivalent versions of the GCRA and their corresponding parameters are shown below.

	ITU-T recommendation	virtual scheduling	leaky bucket
	I.356	algorithm	algorithm
one-point CDV	$y_k'$	TAT - $t_a$	$x'$
Limit parameter/ CDV tolerance	$\tau$	L	L
increment parameter/ peak emission interval	T	I	I

#### A.4.1 Maximum one-point cell delay variation.

Maximum one-point cell delay variation is the maximum value of the one-point CDV variable X' in the continuous-state leaky bucket implementation of the Generic Cell Rate Algorithm over the time period t1. The increment parameter I is an input parameter to the one-point CDV measurement and should be set to be greater than or equal to the reciprocal of the average received cell rate. The test against the Limit parameter L may be disabled or the maximum one-point CDV measurement can be limited to the value chosen for L.

Text from ATMF 95-1306 (TTC):

#### A.5 Test Cell Format

Figure A.5 below illustrates the modified proposal for the ATM test cell. This is a slight modification of the O.191 test cell, where the "version" code has been replaced with two 4-bit fields for controlling interpretation of the cell at the receive side. The CRC-16 has been replaced with a CRC-10, and a second time stamp has been added for round-trip applications. The application of the scrambling sequence described in Appendix 1 of reference 4 has been changed to be optional, and the presence or absence of scrambling is determined by the value present in the "Scrambling Identifier" field, described below.

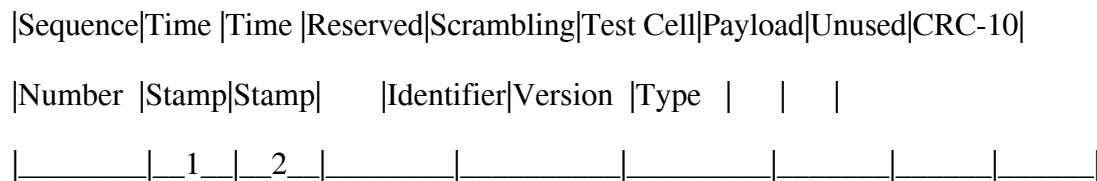

Figure A.5: Test Cell Payload Structure

##### A.5.1 Sequence Number

The sequence number is identical to that field described in contribution 95-0608. It is a 24-bit binary number which is incremented for each cell transmitted on a test cell connection. The field is to be used in detecting lost, misinserted, and out of sequence cells.

##### A.5.2 Time Stamp 1

A 32-bit accumulator which is identical in form and function to the time stamp defined for OAM PM cells in the B-ICI Specification Version 1.1. [3] This time stamp is applied to a cell

immediately prior to the time that the cell is emitted from the test cell source, and before the CRC-10 is calculated over the cell payload.

### A.5.3 Time Stamp 2

Also a 32-bit accumulator which is identical in form and function to the time stamp defined for OAM PM cells in the B-ICI Specification Version 1.1. [3] If this behavior is supported and a return virtual channel is available, this time stamp is applied to a cell at the destination prior to returning a cell to the source. The request to return a cell will be indicated with a bit in the Payload Type field, described below. If this second time stamp is not supported by the test cell source, the field should be encoded with the value 0.

### A.5.4 Reserved

The reserved section of the test cell is currently unused, but reserved for future added fields which may be needed to support new measurements. If scrambling is not applied to the test cell body, all octets in the reserved section of the cell should be encoded with the hexadecimal value 6A. If scrambling is enabled, the reserved section should be encoded with the value 0.

### A.5.5 Scrambling Indicator

This byte is reserved for use at the receive side in determining whether or not the source is applying a scrambling polynomial to the test cells. If scrambling is applied to the payload, this byte should be encoded as zero and then scrambled with the rest of the cell as described in reference 4. If scrambling is not present, this byte should be encoded with the hexadecimal value 6A.

### A.5.6 Test Cell Version

This four-bit field will indicate the version of the test cell structure. This will be encoded with the value 0, and future values will be used to indicate the presence of additional fields in the test cell.

### A.5.7 Payload Type

This field will be specific for each Test Cell Version value. For Test Cell Version 0, the Payload Type field will be used as a bit-mapped field, where the three least significant bits will indicate attributes of the test cell as follows:

**Bit 0:** Indicates the validity of Time Stamp 2. If test equipment places a valid value in the Time Stamp 2 field, it should set this bit as an indication.

**Bit 1:** Indicates the absence of the CRC-10 for error checking. In some cases, it may be difficult or impossible for test equipment under certain circumstances to apply a correct CRC-10 to a test cell. If this is so, the test equipment should indicate this by setting this

bit in the Payload Type field. A value of zero in this bit position confirms the validity of the CRC-10 attached to the cell.

**Bit 2:** Indicates the desire to have the receive end apply a second time stamp and loop the cell back to the source. If this bit is set in a received test cell, the receive end should clear the bit, apply a value into Time Stamp 2, assert bit 0 in the Payload Type field, recalculate the CRC-10, and return the cell to the generator.

### **A.5.8 Unused**

This field consists of 6 unused bits which should be set to 0.

### **A.5.9 CRC-10**

A valid CRC-10 identical to that used for OAM PM cells as described in reference 3. The CRC-10 is chosen to maintain compatibility with existing OAM cell definitions, and to facilitate future test cell support in devices which are currently OAM capable. This will provide investment protection for current investments in test and transmission equipment.

## **A.6 Algorithms**

In order to accomplish the goals set forth in O.191 as described above, it is necessary that not only the format of the test cell, but also the processing associated with deriving a measurement be standardized.

### **A.6.1 Gaining Synchronization to Sequence Number**

For further study

### **A.6.2 Determining the presence of Scrambling**

At the receive side, with scrambling disabled, reception of two consecutive scrambling indicator values of 6A will indicate the absence of scrambling. Similarly, at the receive side with scrambling enabled, reception of two consecutive scrambling indicator values of 0 will indicate the presence of scrambling. The receiving ATM tester should inspect two test cells with valid CRC-10 fields indicating no payload errors and use the above tests to determine whether or not scrambling is present or not on the test cell.

### **A.6.3 Detecting and Accumulating Errored Cells**

The CRC-10 field present in the cell should be used to determine the presence of errors in the payload of the received test cell. Cell Error Ratio would then be calculated as indicated in section A.2.1 of reference 1.

### **A.6.4 Detecting Lost, Out-of-Sequence and Misinserted Cells**

Adopt the algorithm described in reference 4.

Text from ATMF 95-1576 (HP):

## **B.1 Measurement of QoS Parameters using OAM Flow**

Performance Management OAM techniques (ref 1,2) have been designed to allow in-service measurement of ATM performance parameters. This is the primary test methodology to be used by ATM network and end equipment.

To perform out-of-service measurement of ATM performance parameters, a format for an ATM test cell has been under discussion in both the ATM Forum and the ITU.

## **B.2 Overview of performance management OAM**

Performance management OAM cells are inserted periodically into the user data stream (every  $n$  user cells where  $n$  can equal 128, 256, 512, 1024). VP OAM cells are identified by using VCI=3 for segment OAM and VCI=4 for end-to-end OAM. VC OAM cells are identified by using a PTI value = 100 for segment OAM and a PTI value = 101 for end-to-end OAM. An end-to-end OAM cell flow forms part of the user traffic contract.

The performance management OAM cells carry fields that allow measurement of impairments experienced by the user cell stream. The following measurements can be performed: BEDC errors, cell loss, cell misinsertion and two-point cell delay measurements (using optional timestamp).

A forward monitoring OAM cell allows measurement of the user cell stream in the forward direction. A backward reporting OAM cell reports back the results gathered at the far end.

## **B.3 Out-of-service use of performance management OAM**

In addition to the in-service application, it is proposed that a basic method for out-of-service testing of ATM networks is defined in which end-to-end performance management OAM cells are transmitted and the user data cells are replaced with a dummy load. This dummy load could be a PRBS or fixed pattern. A PRBS would be the best load to use to check network transparency (that is to check that the network carries all bit patterns correctly). In addition to the measurements performed on the performance management OAM cells, a cell or bit error ratio measurement may be performed on the received payload if required.

Performance management OAM capability may be designed into ATM network or end equipment. This is therefore a convenient test method to use if network management systems control the out-of-service test or if test equipment analyzes a test signal generated by a network element.

## **B.4 Benefits of performance OAM technique**

Use of performance OAM out-of-service would have the following benefits:

- \* A single test methodology for in-service and out-of-service testing ensures that results obtained in each situation will be comparable.
- \* Because OAM cells arrive at a lower rate than user cells, there is more time available for processing measurements. This is particularly useful in processor-based measurement architectures.
- \* Because the sequence number used is eight bits (as opposed to 24 bits in the out-of-service test cell), measurement processing is simpler.
- \* Because of the widespread deployment of performance OAM techniques in ATM network elements, off-the-shelf devices are readily available to perform these functions.
- \* Testing an ATM network using performance OAM tests the network's ability to carry the OAM flows as well as user data.
- \* The backward reporting mechanism would provide a convenient method for test equipment to communicate results.
- \* Where simultaneous measurements on multiple channels are performed, use of performance OAM allows a mixture of in-service and out-of-service testing to be performed. In this case, channels carrying live traffic can be monitored at the same time as test channels.
- \* It is a simple test method that will result in economical implementation of low-end ATM test equipment.

Because only the OAM cells carry a timestamp, the cell delay and cell delay variation (CDV) measurements obtained are only of a sampled nature. This should not be a problem when computing mean cell transfer delay, but some extremities of the CDV characteristic may not be seen. By using one-point CDV measurement techniques, the CDV characteristic is obtained for all cells. This is only relevant for a CBR distribution but this is where CDV measurement is mostly required.

#### **B.5 ATM test cell**

Use of performance management OAM out-of-service is a complementary test method to using the ATM test cell. Use of the test cell is necessary to isolate cell loss, misinsertion and missequencing errors more precisely. Also, precise evaluation of cell delay and cell delay variation requires a more frequently transmitted timestamp than that provided by OAM cells.

## **6. Status and Conclusion**



This document has introduced performance benchmarking, discussed the role of ATM Forum's goals and non-goals. Also the testing has been confined to the ATM layer and the AAL-5 layer for the present, though higher layer testing will be addressed later. The living list which talks of the work done so far in in-service and out-of-service measurement of QoS parameters has been provided.