

Fundamentals of Telecommunications

Raj Jain

**Raj Jain is now at
Washington University in Saint Louis
Jain@cse.wustl.edu
<http://www.cse.wustl.edu/~jain/>**



- ❑ Single phone conversation: m-Law and A-Law
- ❑ Multiplexing: T1 Framing, Signaling, Frame Formats
- ❑ Digital TDM Hierarchy
- ❑ Echo Cancellation
- ❑ Signaling: Functions, modes

Time Division Multiplexing

- ❑ Voice signal has a bandwidth of 4 kHz
(300 Hz to 3300 Hz is transmitted on phone systems)
- ❑ Nyquist sampling theorem:
Sample at twice the highest signal frequency
⇒ Sample at 8 kHz ⇒ Sample every 125 μ sec
- ❑ 256 levels ⇒ 8 bits per sample \times 8000 samples/sec
= 64 kbps

PCM and Companding

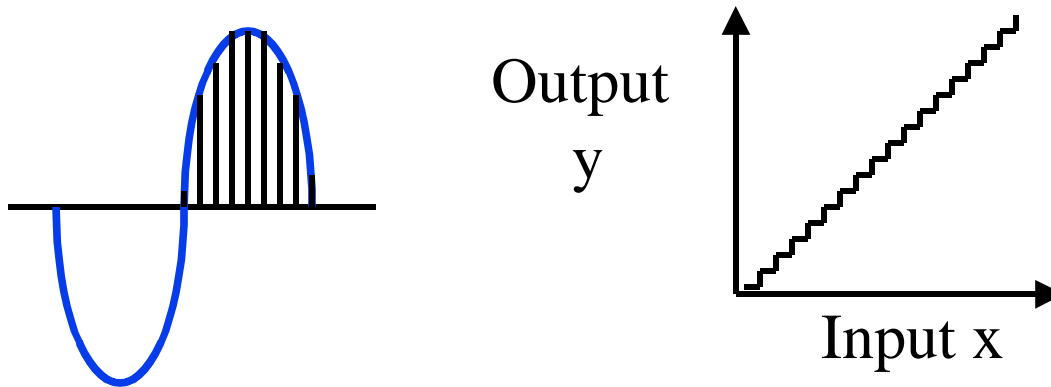

- ❑ Analog voice to Digital Signal
⇒ Pulse code modulation (PCM)
- ❑ Difference between actual and transmitted level
⇒ Quantizing noise. More perceptible at low levels.
⇒ Expand the number of levels at low amplitudes
Compress at high amplitudes = Companding

μ -Law and A-Law

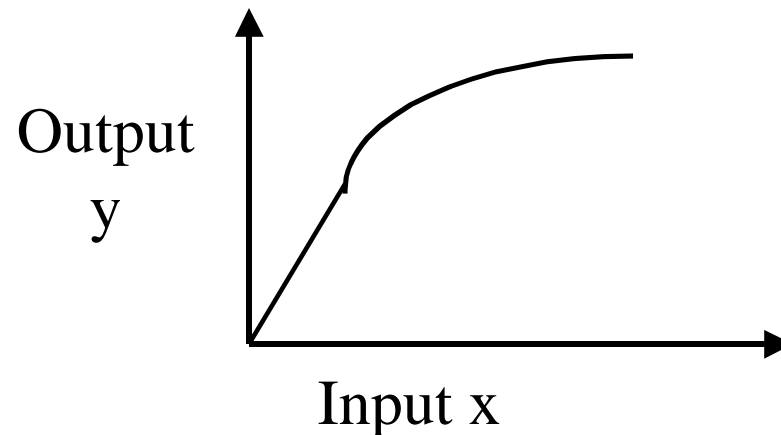

- ❑ In North America: μ -Law

$$y = \ln(1 + \mu x) / \ln(1 + \mu), \quad \mu = 255$$

- ❑ In Europe: A-Law

$$y = (1 + \ln Ax) / (1 + \ln A), \quad A = 87.6$$

- ❑ Linear for small values of x ($x \leq 1/\mu$ or $x \leq 1/A$) and logarithmic for larger values.

Echo Cancellation

- q Problem: Full duplex transmission over a single pair
- q Solution 1: FDM for the two directions.
⇒ Only half of the bandwidth for each direction
- q Solution 2: Use digital signal ⇒ Some part of the signal returns (echo). Near-end and far-end echoes

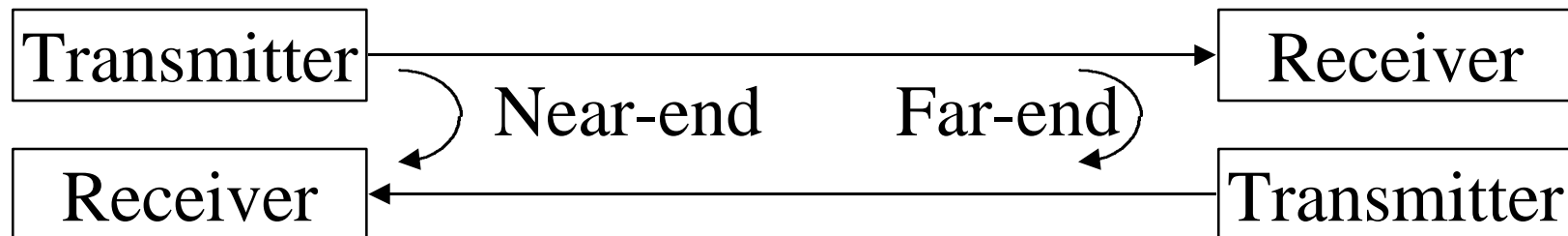

- Echo Cancellation: Reflections from various distances along the path are estimated and subtracted from the received signal ⇒ 144 kbps up to 4 km

300 bps over Single Pair

- 300 bps modems (Bell 108 specification)
- Use frequency shift keying
 - 0 \Rightarrow 1070 Hz, 1 \Rightarrow 1270 Hz in one direction
 - 0 \Rightarrow 2025 Hz, 1 \Rightarrow 2225 Hz in the other direction

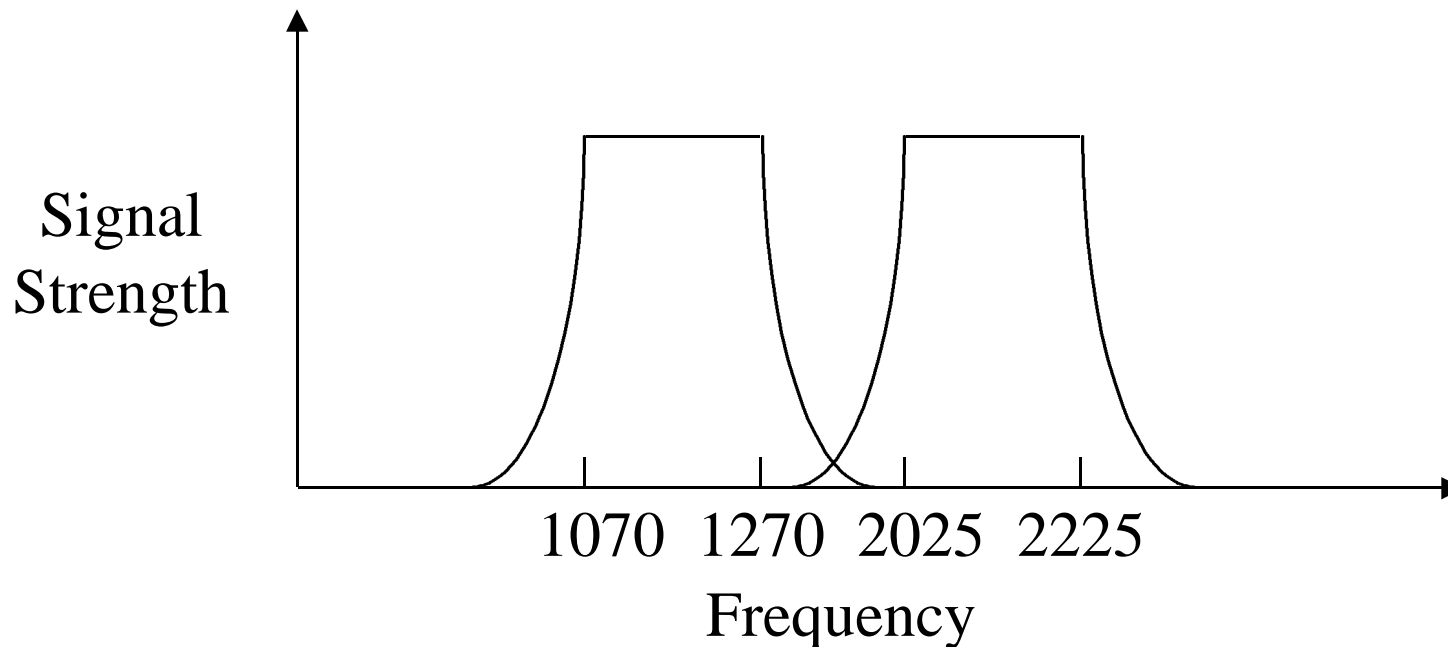

Local Loop

- ❑ Distribution network uses a star topology
⇒ Hierarchical System: Subscribers are connected to local exchanges (or end offices), which are connected via trunks to other tandem or toll switching centers.
- ❑ Feeder cables connect central office to remote nodes. Can be replaced via fiber.
May multiplex using TDM or WDM

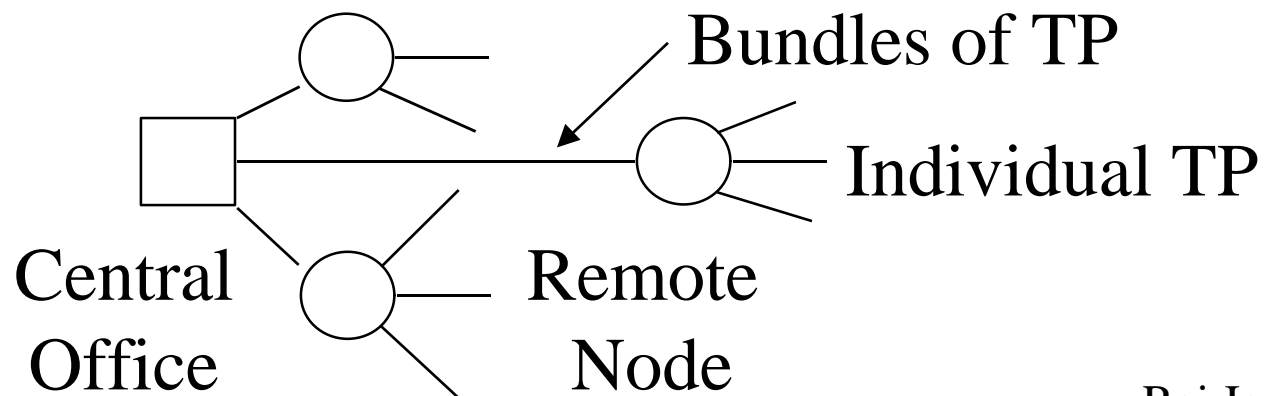

Multiplexing

- ❑ Multiple conversations \Rightarrow Multiple frequency bands
Frequency division multiplexing (FDM)
Useful for analog signals.
- ❑ In 1962, telephone carrier cable between Bell System offices could carry approx 1.5 Mbps over a mile
= Distance between manholes in large cities
= Distance between amplifiers
- ❑ $1500/64 \approx 24 \Rightarrow$ Can multiplex approx.
24 voice channels on that carrier
 \Rightarrow Telecommunication-1 carrier or T1 carrier.
Named after the ANSI committee.

T1 Frame

- T1 = 24 voice channels
= Digital Service 1 = DS1

- Used time-division multiplexing:

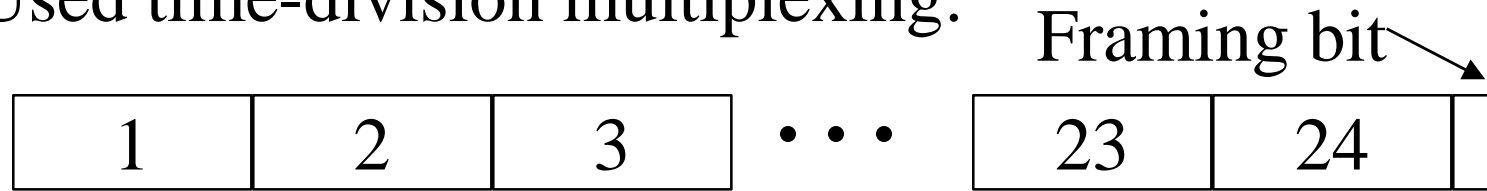

← T1 Frame = 193 bits/125 μ s →

- q Simple Framing: Add 101010 (1 bit per frame)



- q Any other sequence \Rightarrow Resynchronize

T1 Signaling

- ❑ On-hook/off-hook or destination address = Signaling
- ❑ Initially, manual through operators
Later through switches
- ❑ In T1-frames, initially, the 8th bit of every 6th frame in each channel was used for signaling
- ❑ 8th bit is not reliable
⇒ Use only 7 bits per frame ⇒ 56 kbps
- ❑ In the newer PRI (primary rate interface) format used with ISDN, the signaling information of 23 channels is combined into a separate 24th channel.
Each user gets full 64 kbps.

D4 and ESF Frame Formats

Frame #	193 rd bit	Use	193 rd bit	Use
1	1	FT	X	FDL
2	0	FS	X	CRC
3	0	FT	X	FDL
4	0	FS	0	FS
5	1	FT	X	FDL
6	1	FS	X	CRC
7	0	FT	X	FDL
8	1	FS	0	FS
9	1	FT	X	FDL
10	1	FS	X	CRC
11	0	FT	X	FDL
12	0	FS	1	FS
13			X	FDL
14			X	CRC
15			X	FDL
16			0	FS
17			X	FDL
18			X	CRC
19			X	FDL
20			1	FS
21			X	FDL
22			X	CRC
23			X	FDL
24			1	FS

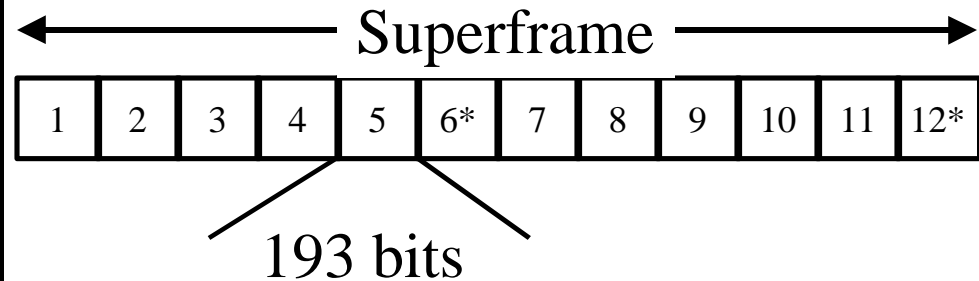

D4 Format superframe = 12 Frames

ESF format extended superframe = 24 Frames

FT = Terminal Framing Bit

FS = Multiframe Alignment

FDL = Datalink bit (M bit)

CRC = Cyclic Redundancy Check bit

X = Data dependent

Subrate Multiplexing

- ❑ Used for data rates lower than 56 kbps.
- ❑ One bit of the 7 bits is used to indicate data rate
- ❑ 6 bits per channel = 48 kbps
 - Five 9.6 kbps subchannels
 - Ten 4.8 kbps subchannels
 - Twenty 2.4 kbps subchannels
- ❑ Five subchannels \Rightarrow Subchannel 1 uses frames 1, 6, 11, ...

European System: E1

- ❑ European counter part of American T1
- ❑ Designed by Conference of Post and Telecommunications (CEPT)
- ❑ 32 bytes per 125 μ s frame = 2.048 Mb/s
 - 30 channels are used for data
 - One channel for synchronization
 - One channel for signalling

Digital TDM Hierarchy

North America		Europe		Japan	
DS0	64 kbps		64 kbps		64 kbps
DS1	1.544 Mbps	E1	2.048 Mbps	J1	1.544 Mbps
DS2	6.313 Mbps	E2	8.448 Mbps	J2	6.312 Mbps
DS3	44.736 Mbps	E3	34.368 Mbps	J3	32.064 Mbps
DS4	274.176 Mbps	E4	139.264 Mbps	J4	97.728 Mbps
DS1C	3.152 Mbps	E5	565.148 Mbps	J5	397.200 Mbps

Signaling

- ❑ Signal = Control
- ❑ Signaling in telephone networks
= Control messages in computer networks
- ❑ Examples:
 - Connection setup request
= Off-hook signal from telephone to switch
 - Connection setup acknowledge = Dial tone
 - Destination address = Pulse or tone dialing
 - Destination busy = Busy tone
 - Destination Available = Ringing tone

Other Signaling Functions

- ❑ Transmission of dialed number between switches
- ❑ Transmission of information between switches indicating that a call cannot be completed
- ❑ Transmission of billing information
- ❑ Transmission of information for diagnosing and isolating failures
- ❑ Control of satellite channels

Types of Signaling Fns

- ❑ **Supervisory:** To obtain resources to establish/hold/release a connection.
- ❑ **Address:** Identify destination. Subscriber to switch. Between switches.
- ❑ **Call information:** Provide call status to the calling subscriber
- ❑ **Network Management:** Operation, troubleshooting, and maintenance of the network. Not directly involved in call establishment/termination.
- ❑ Signaling between a subscriber and the network is different (simple) from that inside the network.

Signaling Channel

- ❑ In-band signaling \Rightarrow Signaling over the same channel as payload
- ❑ Out-of-band signaling \Rightarrow Separate channels for signaling (but may be same physical circuits)
- ❑ Common Channel Signaling (CCS)
 - \Rightarrow Separate circuits for signaling
 - \Rightarrow Allows several new functions, such as 800

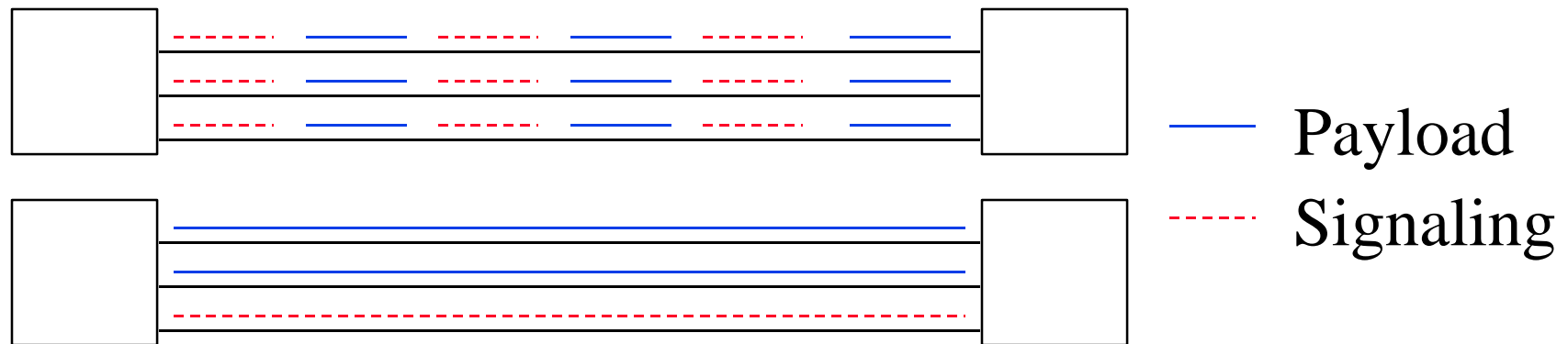

Signaling Modes

- ❑ Associated Mode: CCS follows the same path as payload
- ❑ Nonassociated Mode: CCS uses a separate network

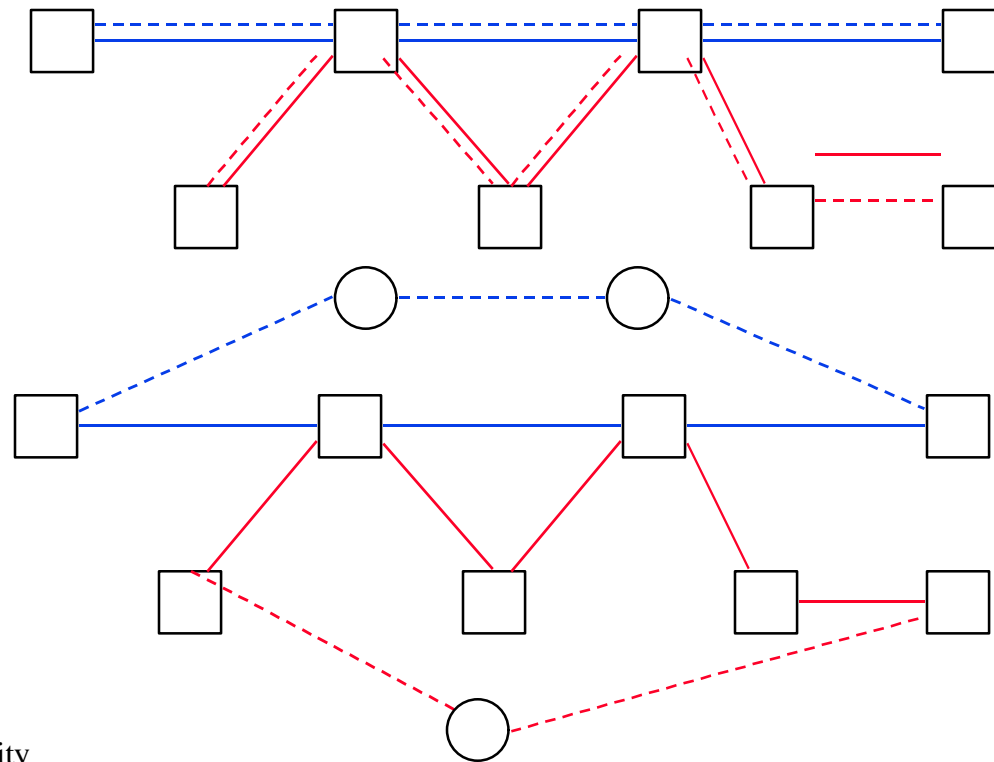

Summary

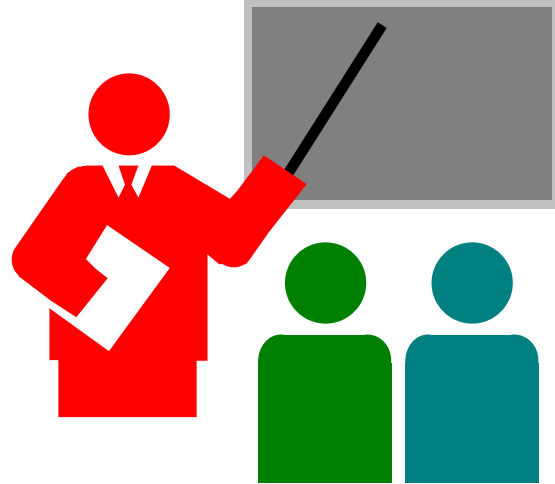

- ❑ T1, DS1, DS3, ...
- ❑ T1 Frames consist of 193 bits per 125 μ s.
- ❑ Echo cancellation is required if sharing the same wire-pair for both directions.
- ❑ Signaling: In band vs Common Channel, associated vs non-associated..

Homework

- ❑ Read Sections 2.1.2, 6.1.3-6.3.1 of McDyson's book
- ❑ Submit answer to the following:
What is the percentage of overhead in DS-1 transmission format (percentage of bits that are not user data)?
- ❑ Due: Next Week