

Wireless Data Networking

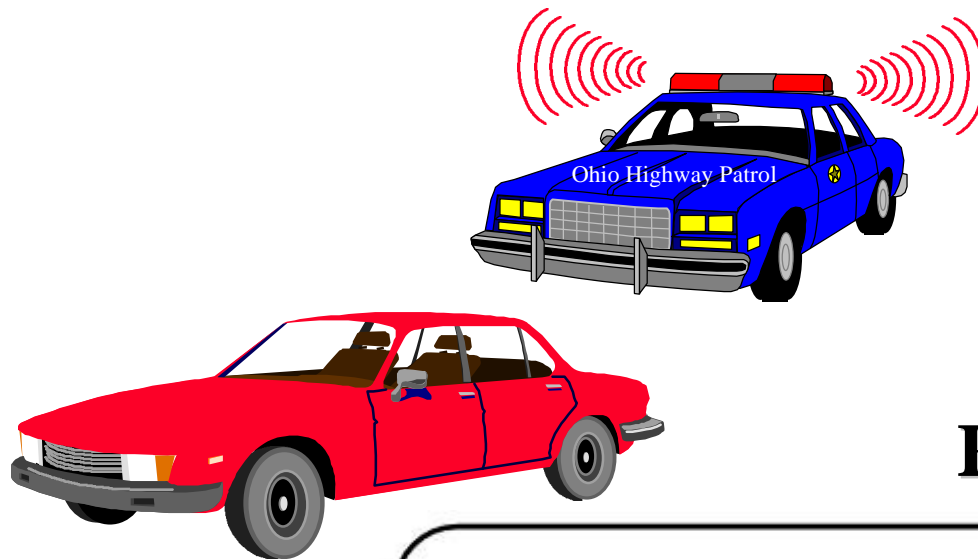

Raj Jain

**Raj Jain is now at
Washington University in Saint Louis
Jain@cse.wustl.edu**

<http://www.wustl.edu/~jain/>

<http://www.cse.wustl.edu/~jain/>

Raj Jain



- ❑ Spread Spectrum
- ❑ Wireless wide area networks: CDPD and Metricom
- ❑ Wireless local area networks
- ❑ Wireless LAN standard: IEEE 802.11, Hiperlan

Note: wireless **phone** services and standards not covered.

Mobile vs Wireless

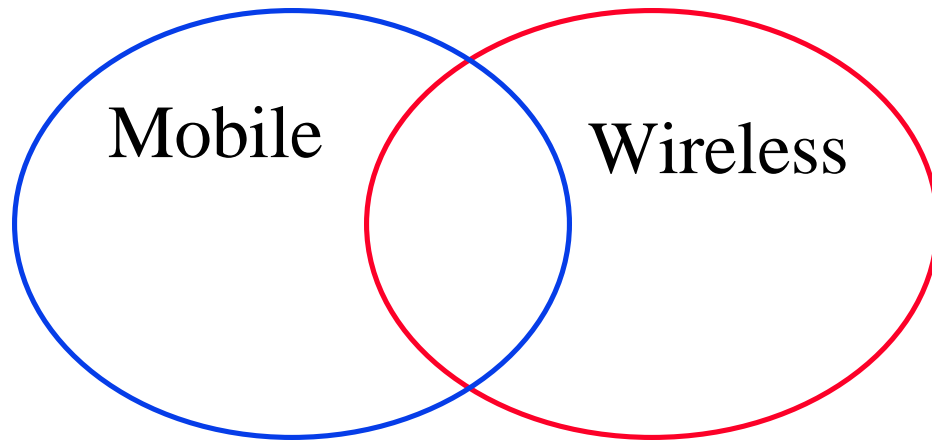

- ❑ Mobile vs Stationary
- ❑ Wireless vs Wired
- ❑ Wireless \Rightarrow media sharing issues
- ❑ Mobile \Rightarrow routing, addressing issues

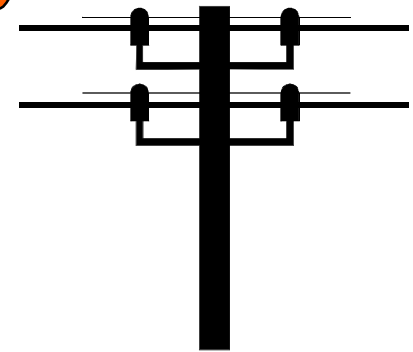



Raj Jain

Frequency Hopping Spread Spectrum

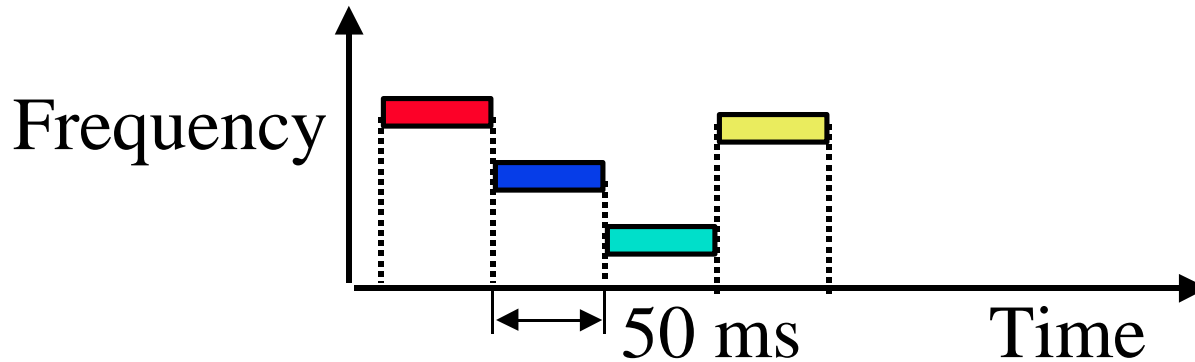

- ❑ Pseudo-random frequency hopping
- ❑ Spreads the power over a wide spectrum
⇒ Spread Spectrum
- ❑ Developed initially for military
- ❑ Patented by actress Hedy Lamarr
- ❑ Narrowband interference can't jam

Spectrum

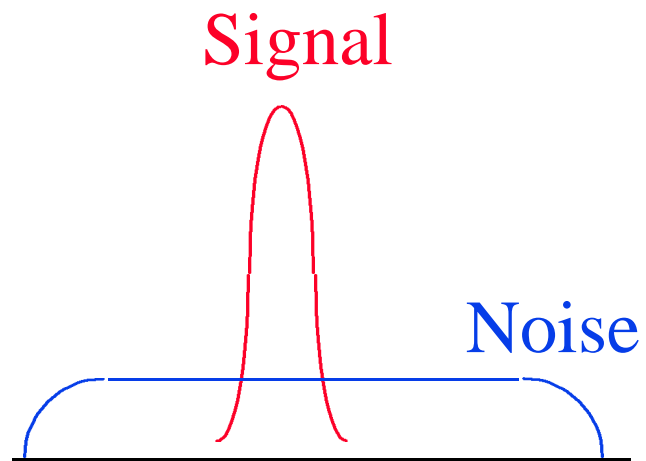

(a) Normal

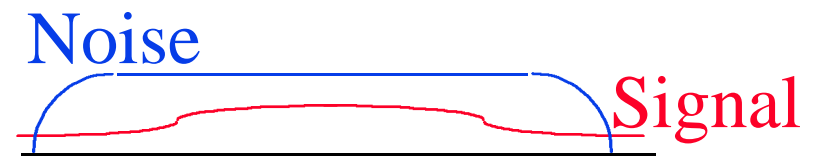

(b) Frequency Hopping

Direct-Sequence Spread Spectrum

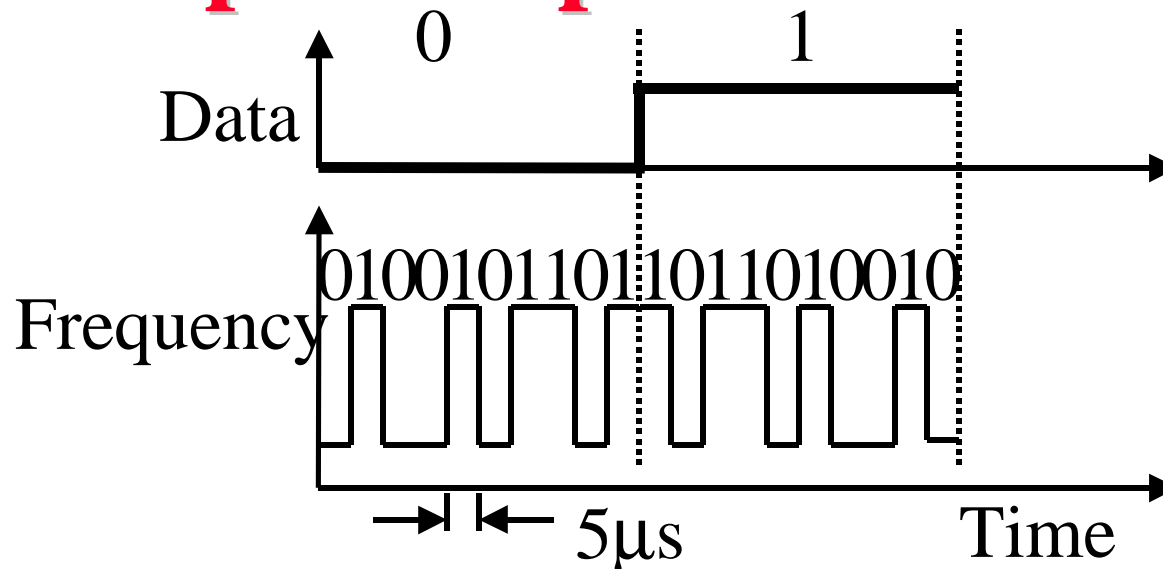

- ❑ Spreading factor = Code bits/data bit, 10-100 commercial (Min 10 by FCC), 10,000 for military
- ❑ Signal bandwidth $>10 \times$ data bandwidth
- ❑ Code sequence synchronization
- ❑ Correlation between codes \Rightarrow Interference \Rightarrow Orthogonal

Raj Jain

DS Spectrum

Time Domain

Frequency Domain

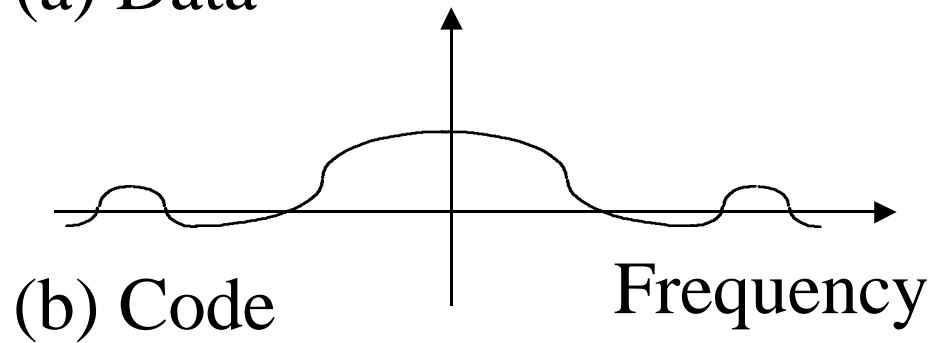
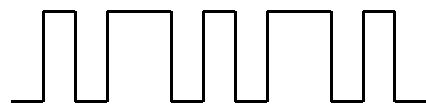
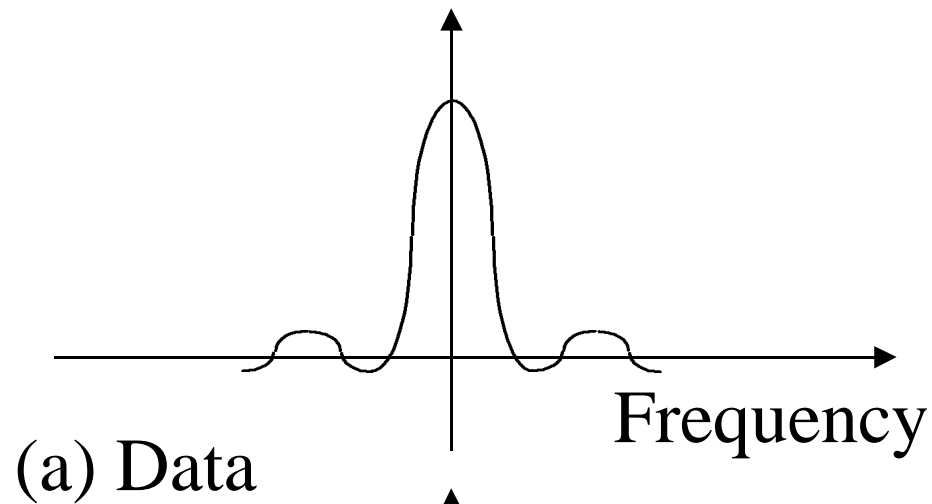
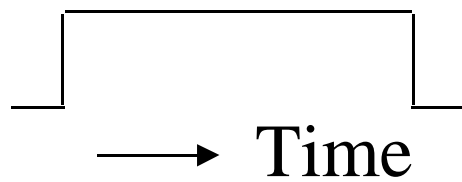

Wireless WAN Services

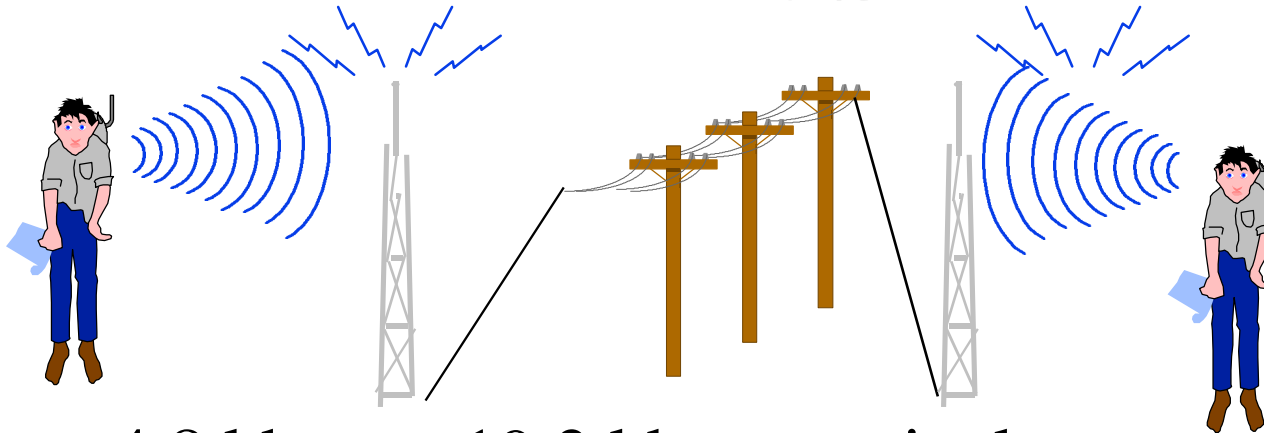

- ❑ 4.8 kbps to 19.2 kbps nominal
- ❑ Throughput 2 to 8 kbps
- ❑ Wired backbone using leased lines
- ❑ Packetized short transmission
- ❑ Email, stock quotes, weather
- ❑ Options: Ardis, RAM Mobile Data, Cellular, Cellular Digital Packet Data (CDPD), and Metricom

Raj Jain

Cellular Digital Packet Data (CDPD)

- ❑ Originally named “Celluplan” by IBM
- ❑ Allows data to use idle cellular channels
- ❑ Data hops from one channel to next as the channels become busy or idle

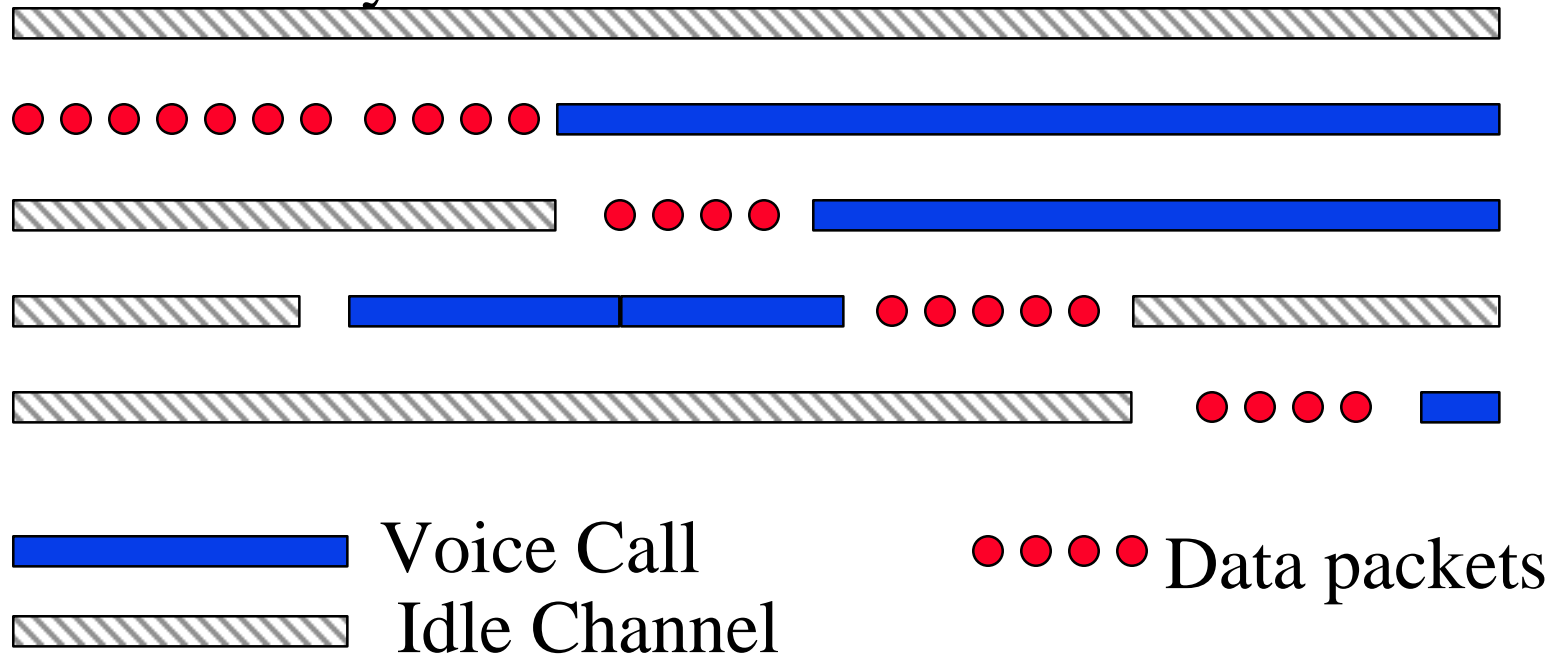

Raj Jain

CDPD

- ❑ Backed by 9 major service providers
- ❑ Nationwide cellular packet data service
- ❑ Connectionless and connection-oriented service
 - Connectionless \Rightarrow No ack, no guarantees
 - Connection-oriented \Rightarrow reliable delivery, sequencing, flow control
- ❑ Point-to-point and multipoint connections
- ❑ Quickly hops-off a channel grabbed by cellular system. Currently, dedicated channels.

Wireless LANs

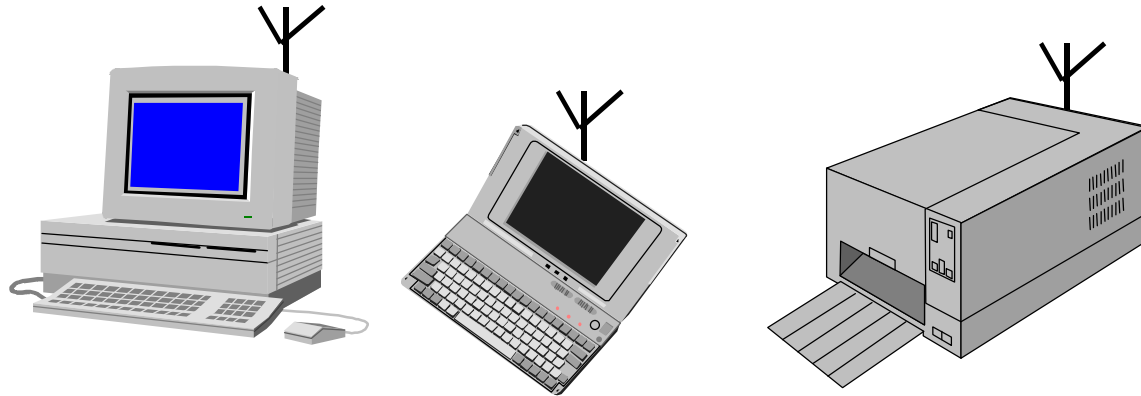

- IR \Rightarrow Line of sight, short range, indoors
- RF \Rightarrow Need license
- Spread-Spectrum: Resistance to interference

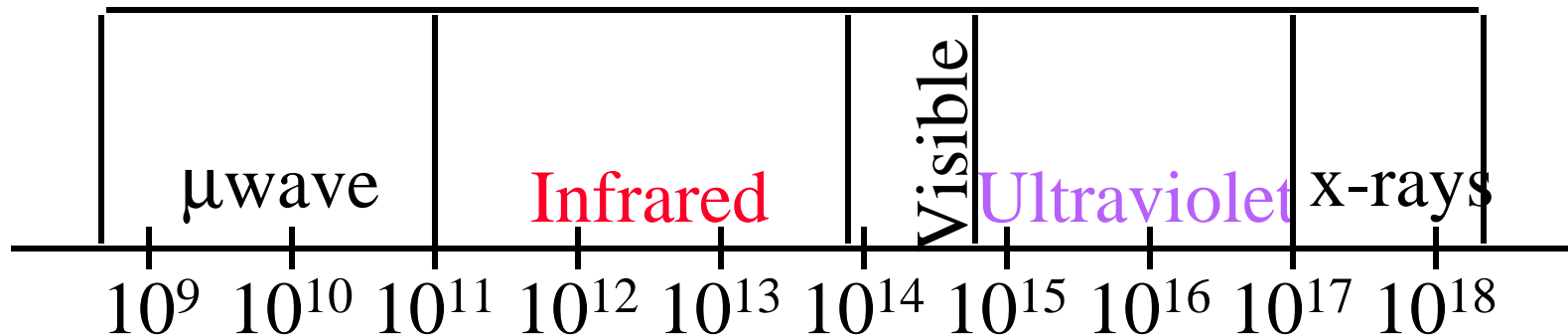

Raj Jain

Wireless LANs

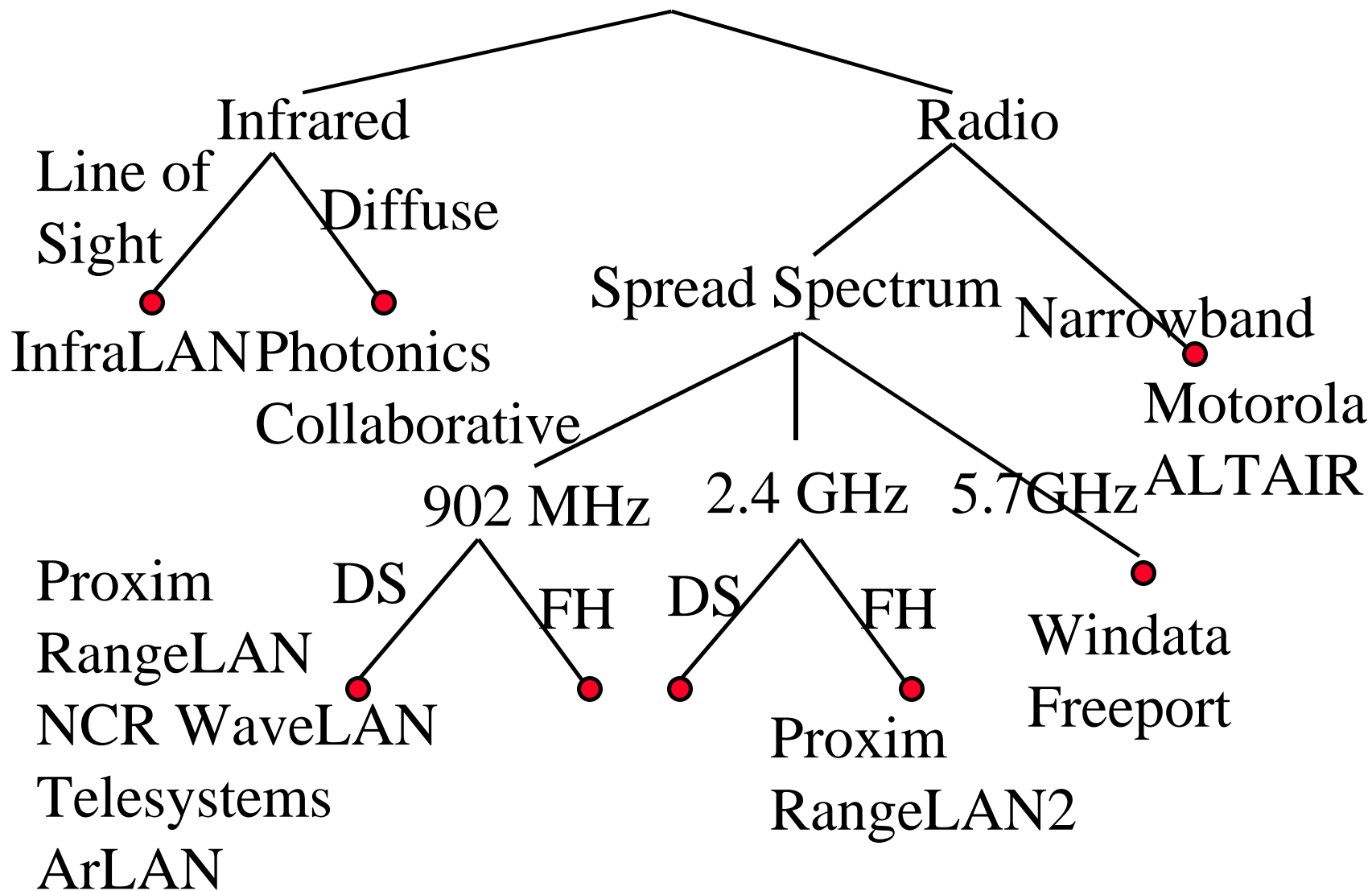

IEEE 802.11 Features

- ❑ 1 and 2 Mbps
- ❑ Supports both Ad-hoc and base-stations
- ❑ Spread Spectrum \Rightarrow No licensing required.
Three Phys: Direct Sequence, Frequency Hopping, 915-MHz, **2.4 GHz** (Worldwide ISM), 5.2 GHz, and Diffused Infrared (850-900 nm) bands.
- ❑ Supports multiple priorities
- ❑ Supports time-critical and data traffic
- ❑ Power management allows a node to doze off

Hidden Node Problem

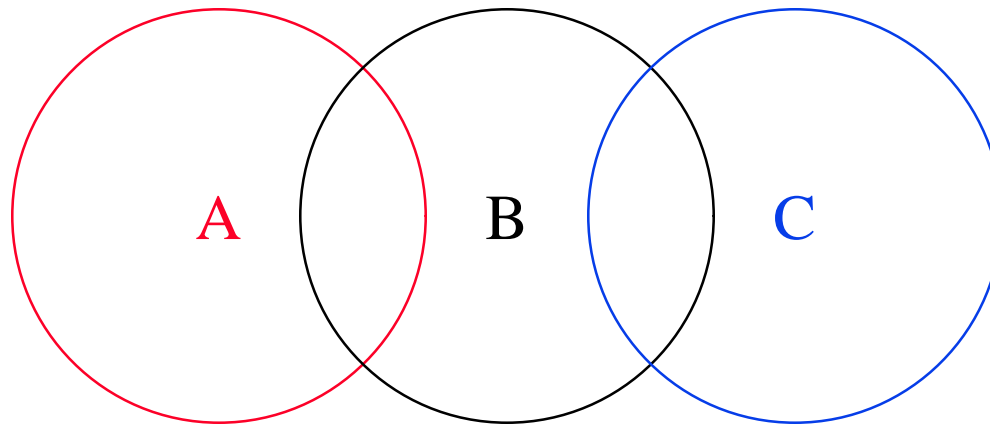

- ❑ C cannot hear A.
It may start transmitting while A is also transmitting
⇒ A and C can't detect collision.
- ❑ Only the receiver can help avoid collisions

4-Way Handshake

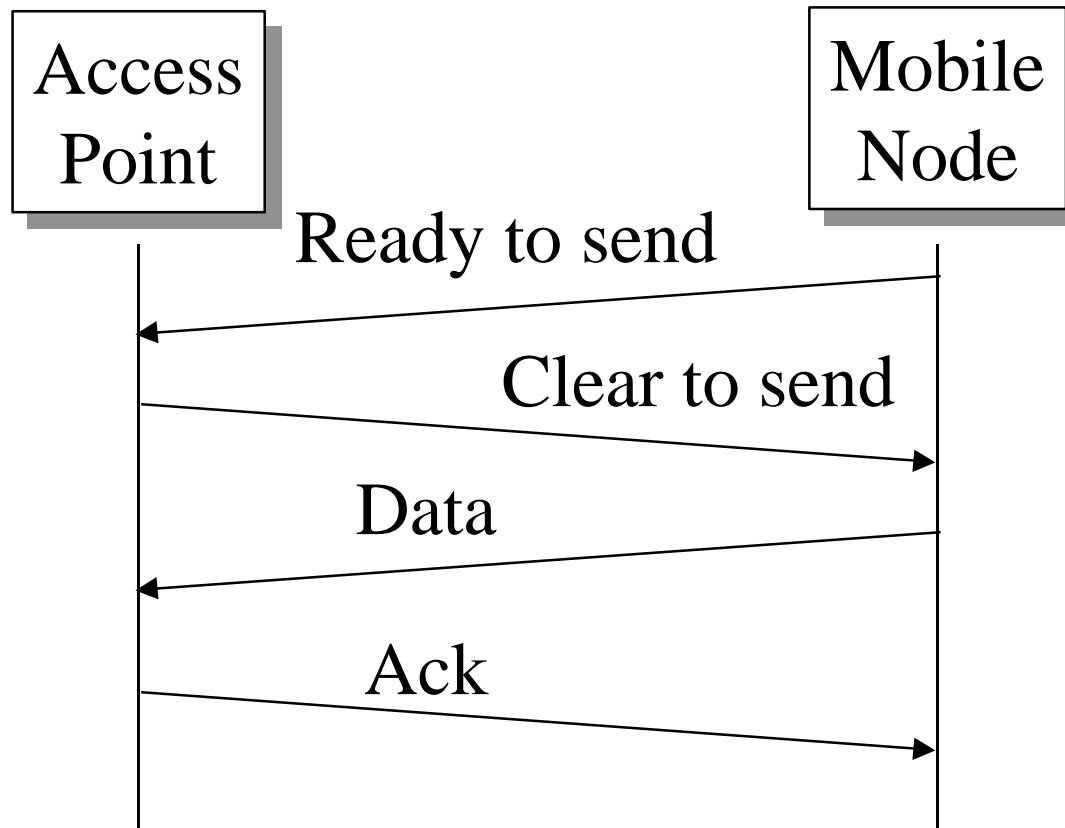

IEEE 802.11 MAC

- ❑ Carrier Sense Multiple Access with Collision Avoidance (CSMA/CA)
- ❑ Listen before you talk. If the medium is busy, the transmitter backs off for a random period.
- ❑ Avoids collision by sending a short message: Ready to send (RTS)
RTS contains dest. address and duration of message.
Tells everyone to backoff for the duration.
- ❑ Destination sends: Clear to send (CTS)
- ❑ Can not detect collision \Rightarrow Each packet is acked.
- ❑ MAC level retransmission if not acked.

Ad-Hoc vs Infrastructure

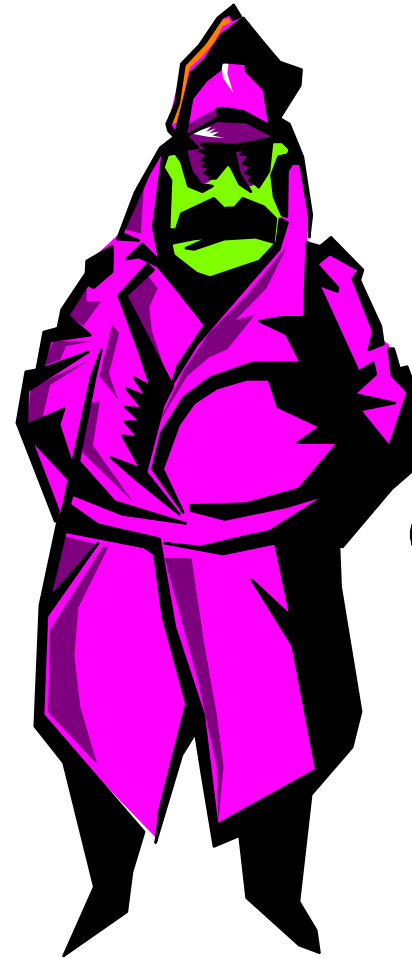
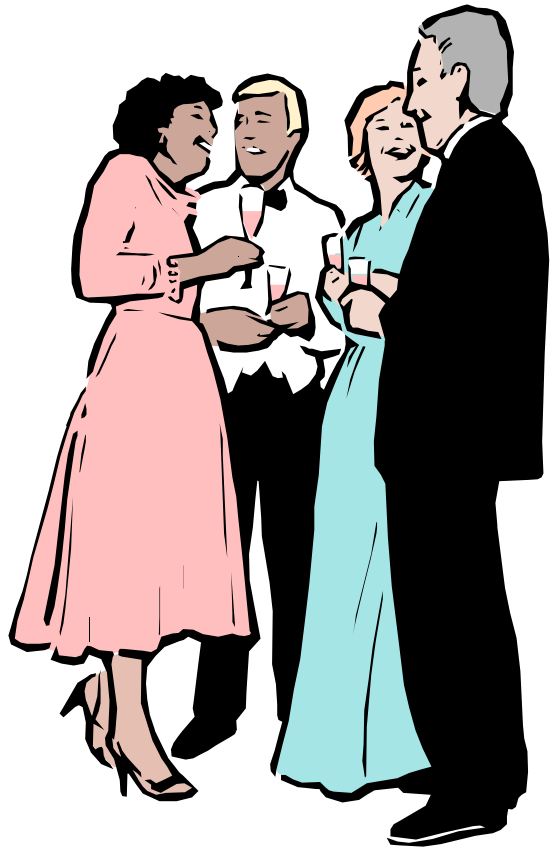

Raj Jain

Peer-to-Peer or Base Stations?

- ❑ Ad-hoc (Autonomous) Group:
 - Two stations can communicate
 - All stations have the same logic
 - No infrastructure, Suitable for small area
- ❑ Infrastructure Based: Access points (base units)
 - Stations can be simpler than bases.
 - Base provide connection for off-network traffic
 - Base provides location tracking, directory, authentication \Rightarrow Scalable to large networks
- ❑ IEEE 802.11 provides both.

IEEE 802.11 Architecture

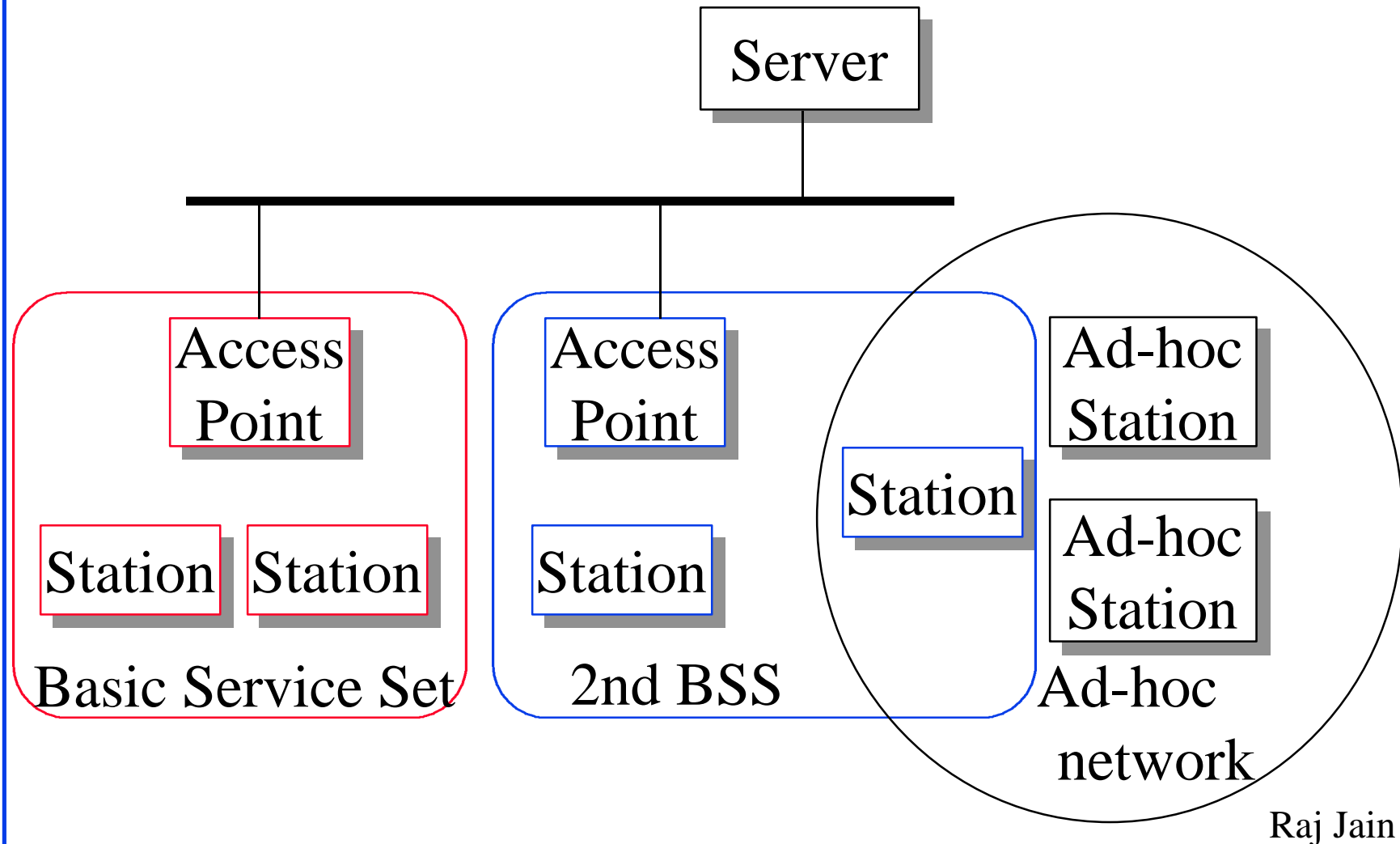

Raj Jain

IEEE 802.11 Priorities

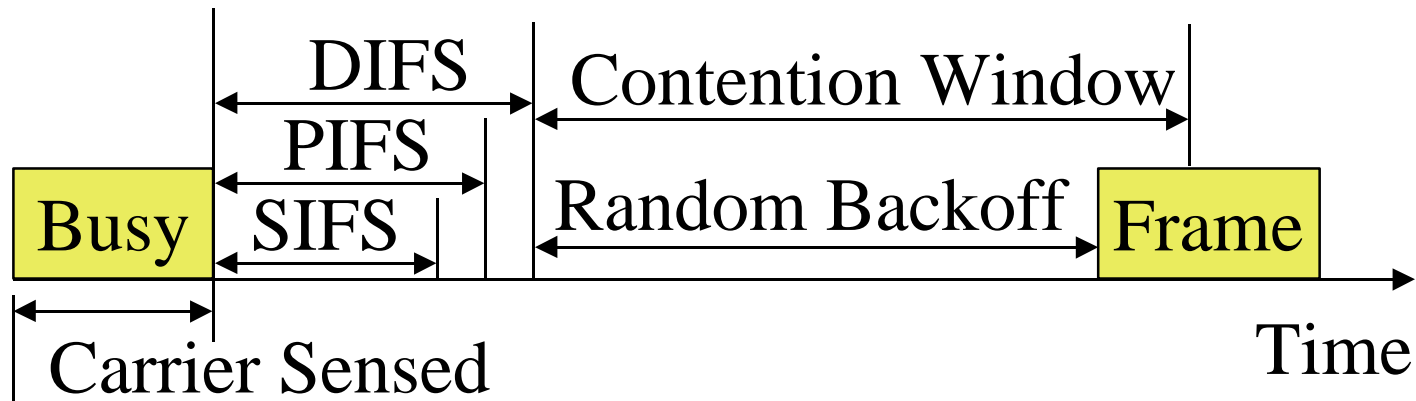

- ❑ Initial interframe space (IFS)
- ❑ Highest priority frames, e.g., Acks, use short IFS (SIFS)
- ❑ Medium priority time-critical frames use “Point Coordination Function IFS” (PIFS)
- ❑ Asynchronous data frames use “Distributed coordination function IFS” (DIFS)

Time Critical Services

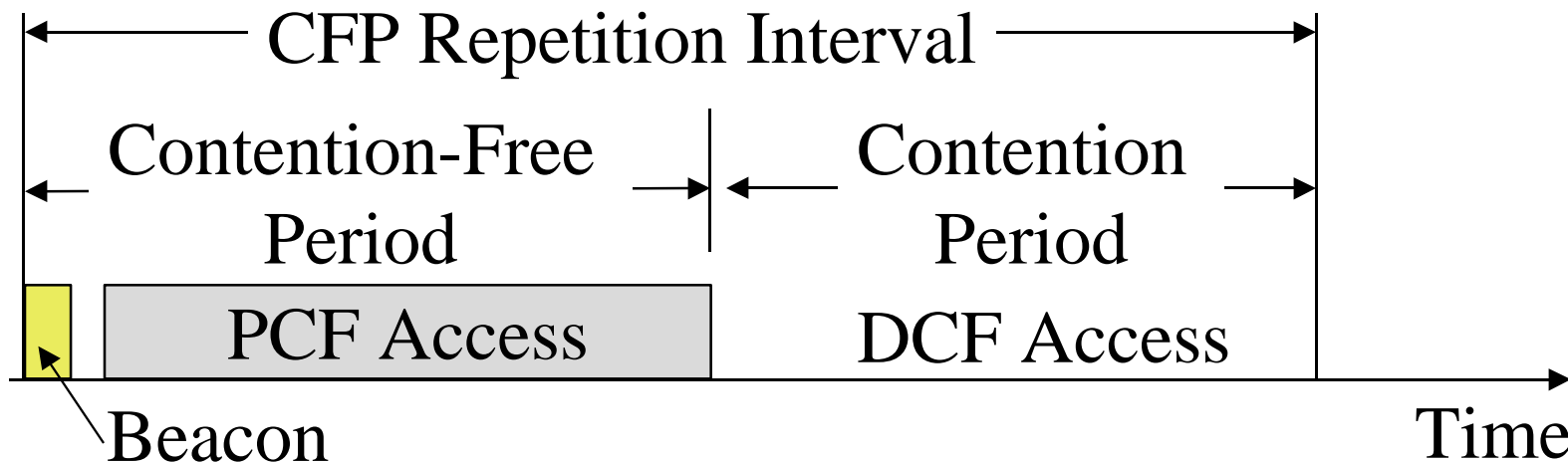

- ❑ Timer critical services use Point Coordination Function
- ❑ The point coordinator allows only one station to access
- ❑ Coordinator sends a beacon frame to all stations. Then uses a polling frame to allow a particular station to have contention-free access
- ❑ Contention Free Period (CFP) varies with the load.

Raj Jain

Power Management

- ❑ A station can be in one of three states:
 - Transmitter on
 - Receiver only on
 - Dozing: Both transmitter and receivers off.
- ❑ Access point (AP) buffers traffic for dozing stations.
- ❑ AP announces which stations have frames buffered.
Traffic indication map included in each beacon.
All multicasts/broadcasts are buffered.
- ❑ Dozing stations wake up to listen to the beacon.
If there is data waiting for it, the station sends a poll frame to get the data.

Status and Future

- ❑ 802.11 including both MAC and PHY approved June 1997.
- ❑ More bandwidth in future by:
 1. Better encoding: Multilevel modulation \Rightarrow 8 Mbps
 2. Fewer channels with more bandwidth \Rightarrow 4 MHz channels. Or Entire ISM band for one channel.
 3. Find another band. May get 150 MHz band in 5-GHz band. Fifteen 10-MHz channels with 15-20 Mb/s.

HIPERLAN

- ❑ High Performance Radio LAN
- ❑ European Telecom Standards Institute (ETSI)'s subtechnical committee RES10.
- ❑ 5.12-5.30 GHz and 17.1-17.3 GHz bands
- ❑ Phy: 23.5 Mbps on 23.5 MHz, non-spread spectrum (GMSK)
- ❑ MAC: CSMA/CA but different from IEEE 802.11
- ❑ Peer-to-peer only.
- ❑ Power management: Nodes announce their wakeup cycle. Other nodes send according to the cycle. A low-bit rate header allows nodes to keep most ckts off.

Raj Jain

Summary

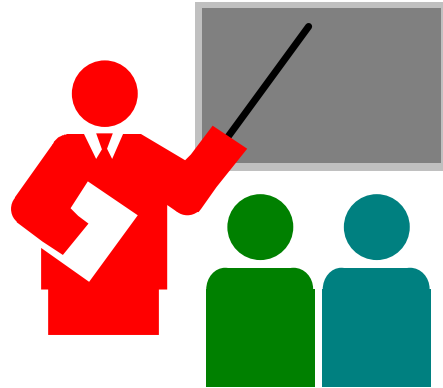

- ❑ Spread spectrum: Frequency hopping or direct sequence
- ❑ WANs: Ardis, RAM, Cellular, CDPD, Metricom
- ❑ Proprietary LANs: Photonics, RangeLan, ALTAIR
- ❑ LAN Standards: IEEE 802.11, Hiperlan

Wireless: Key References

- ❑ For a detailed list of references see:
http://www.cis.ohio-state.edu/~jain/refs/wir_refs.htm
- ❑ E. Prem, “Wireless Local Area Networks,” Aug 97,
http://www.cis.ohio-state.edu/~jain/cis788-97/wireless_lans