

Virtual LANs

Raj Jain

Professor of Computer and Information Sciences

**Raj Jain is now at
Washington University in Saint Louis**

Jain@cse.wustl.edu

<http://www.cse.wustl.edu/~jain/>

7/

MBone Instructions

- ❑ Handouts for the class are available on-line:
<http://www.cis.ohio-state.edu/~jain/cis788-97/index.html> or
<http://www.netlab.ohio-state.edu/~jain/cis788-97/index.html> or
<ftp://netlab.ohio-state.edu/pub/jain/cis788-97/>
- ❑ The schedule keeps changing. Please always check current schedule at:
<http://www.cis.ohio-state.edu/~jain/cis788-97/schedule.html>

Instructions (Cont)

- ❑ Please email your positive and negative feedback about the quality of the reception as well as the content with a subject field of “**Feedback**” to mbone@netlab.ohio-state.edu
- ❑ If you are not able to receive the program due to some technical difficulties, please email “**Feedback**” to mbone@netlab.ohio-state.edu
- ❑ Please email technical questions with the subject field “**Question**” to mbone@netlab.ohio-state.edu. We will try to answer selected questions live.



- ❑ What is a LAN and what is a Virtual LAN?
- ❑ Types of Virtual LANs
- ❑ IEEE 802.1Q standard

What is a LAN?

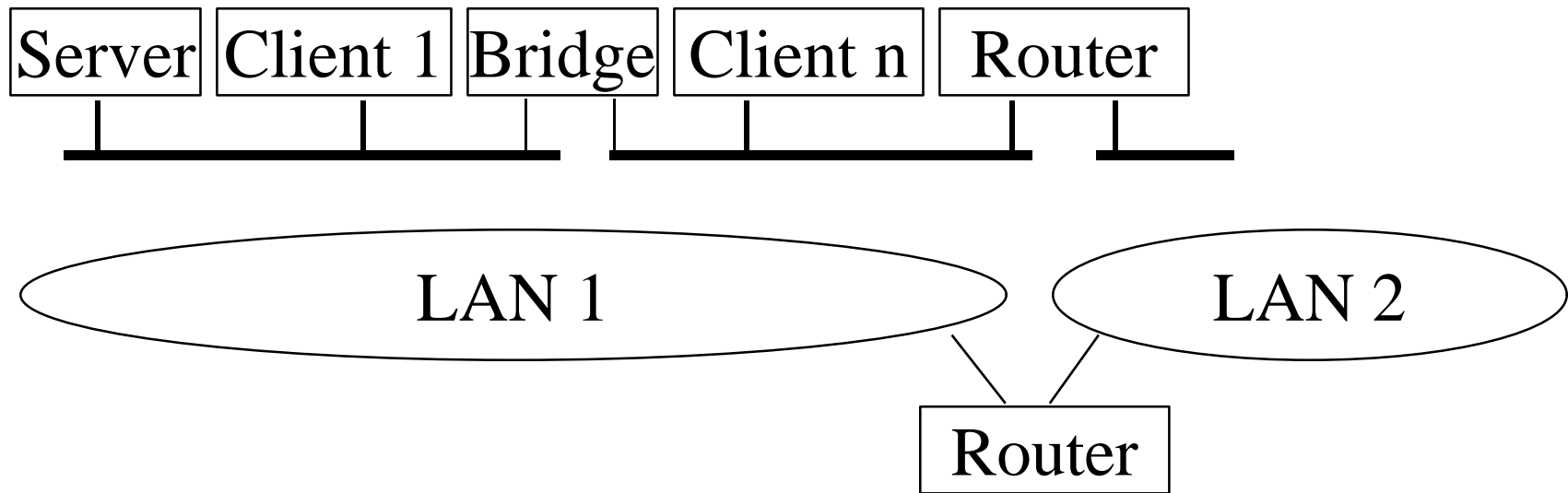

- ❑ LAN = Single broadcast domain = Subnet
- ❑ No routing between members of a LAN
- ❑ Routing required between LANs

What is a Virtual LAN

Physical View

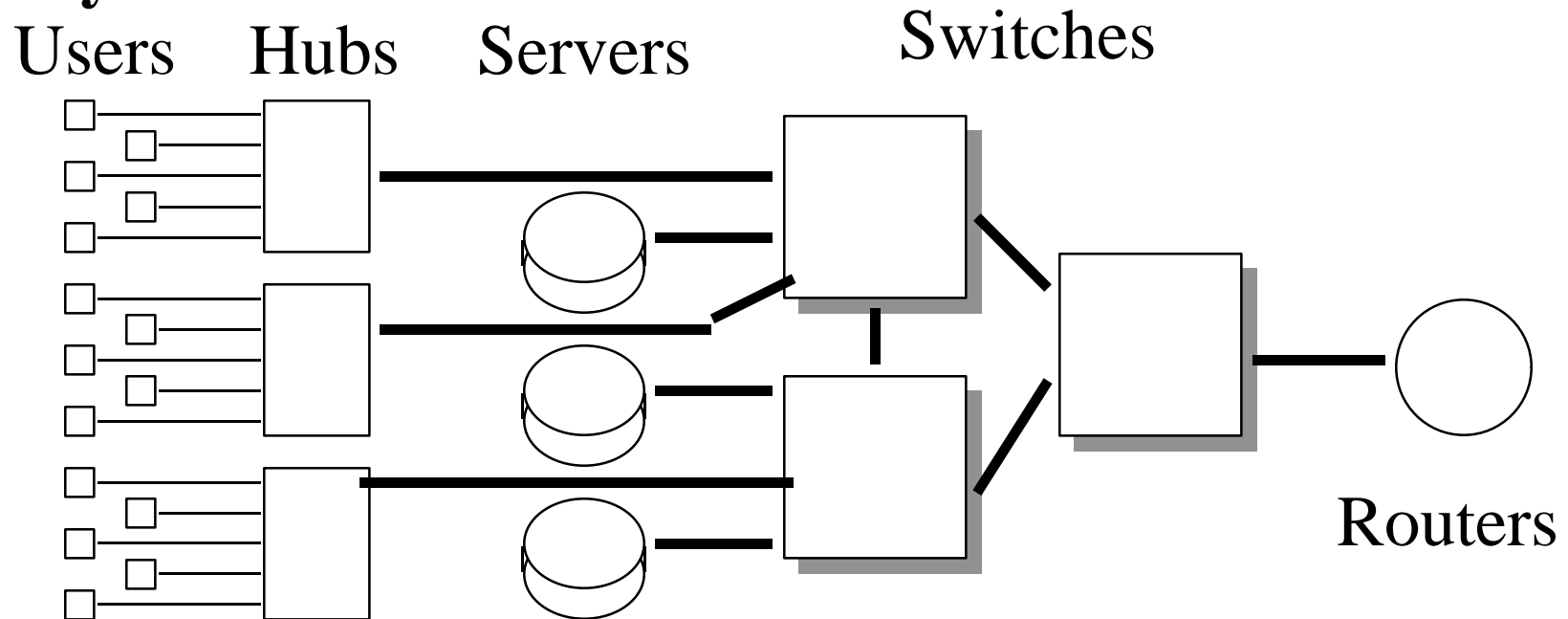

Logical View

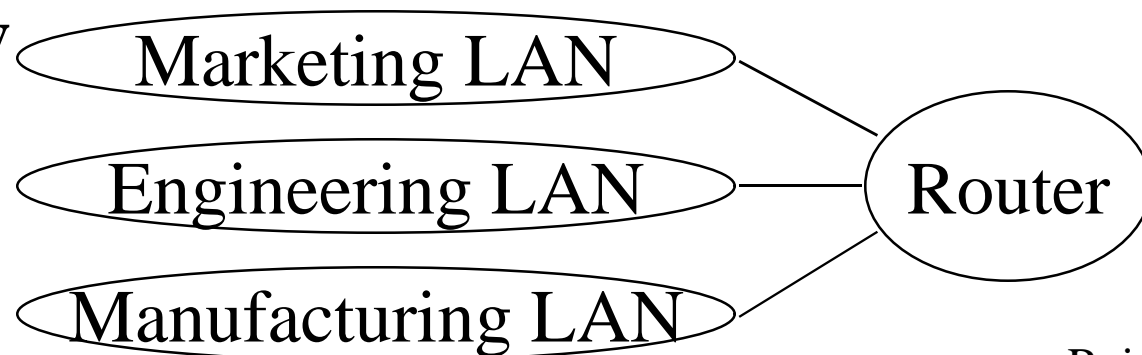

Virtual LAN

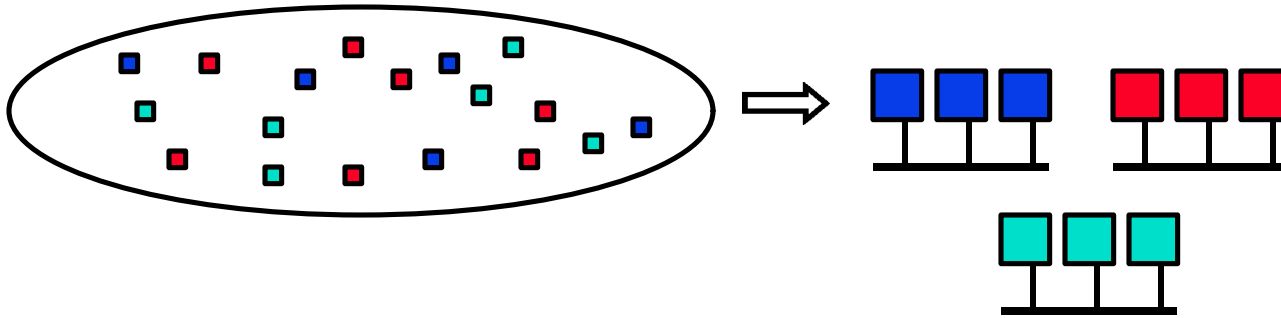

- ❑ Virtual LAN = Broadcasts and multicast goes only to the nodes in the virtual LAN
- ❑ LAN membership defined by the network manager
⇒ Virtual

VLAN: Why?

- Virtual is Better than Real
 - Location-independent
 - ⇒ Marketing LAN can be all over the building
 - Users can move but not change LAN
 - Traffic between LANs is routed
 - ⇒ Better to keep all traffic on one LAN
 - Switch when you can, route when you must
 - ⇒ Do not VLAN over expensive WAN links
 - Better security

Types of Virtual LANs

- Layer-1 VLAN = Group of Physical ports
- Layer-2 VLAN = Group of MAC addresses
- Layer-3 VLAN = IP subnet

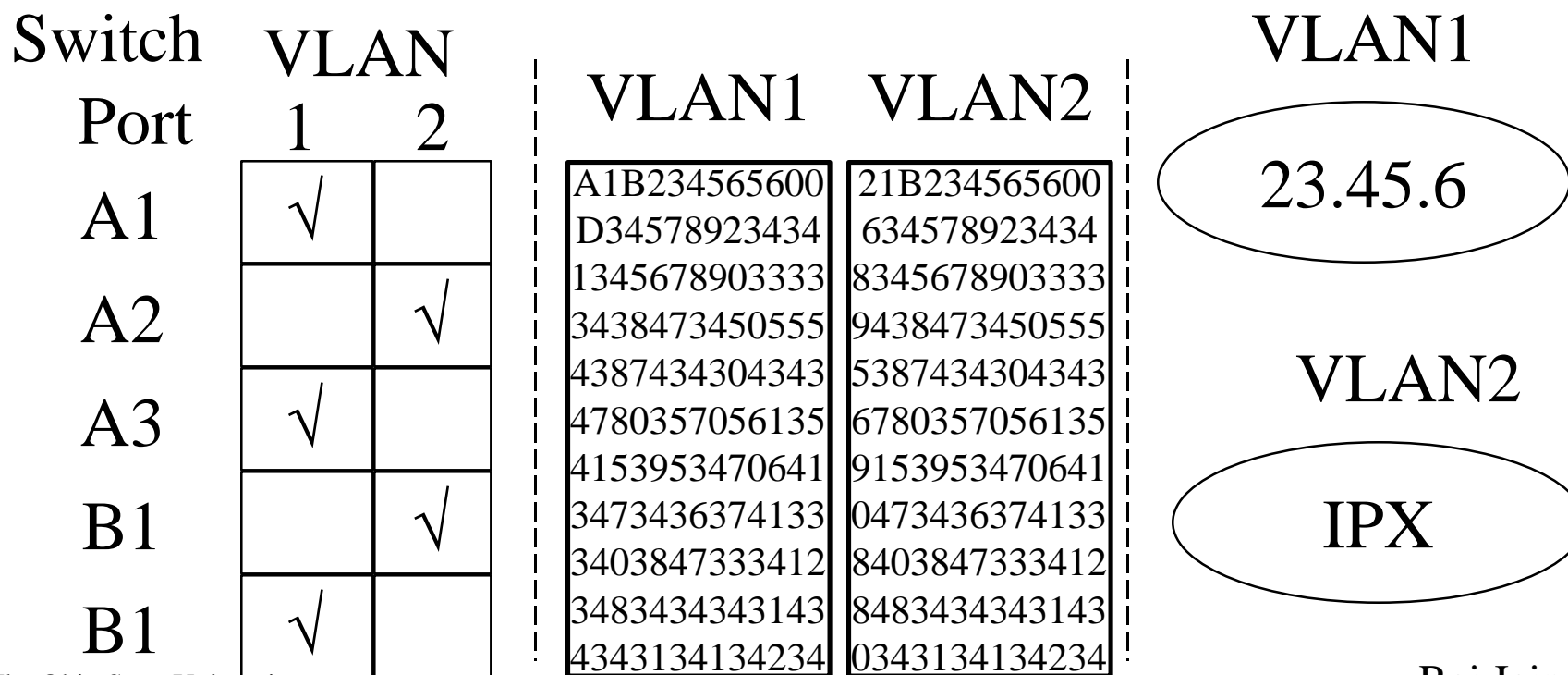

Layer-1 VLANs

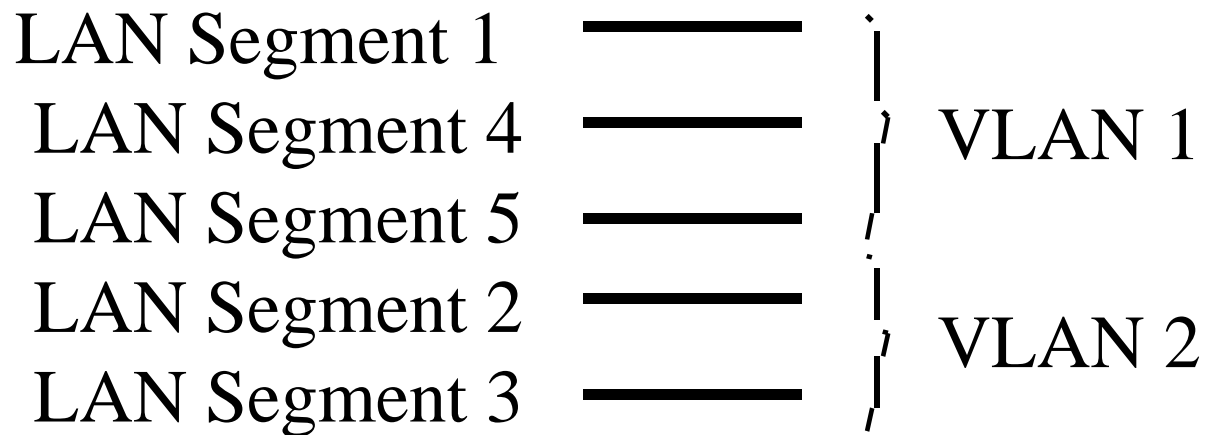

- ❑ Also known as port switching
- ❑ Can be used to provide security and isolation
- ❑ Does not allow user mobility.
- ❑ Moved user has a new subnet \Rightarrow new IP address
 \Rightarrow May go through a router to access the old server

Layer-2 VLANs

- ❑ LANs defined by a list of MAC addresses
- ❑ Provides full user movement
- ❑ Clients and server always on the same LAN regardless of location
- ❑ Problem: Too many addresses need to be entered and managed

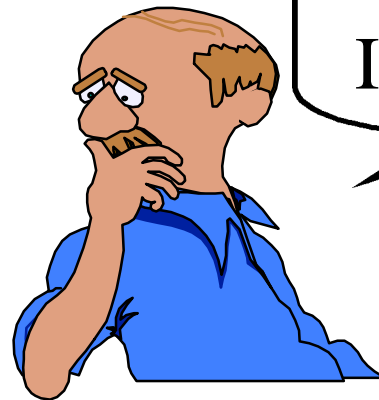

0234786890
Is that a marketing node?

Layer-2 VLANs (Cont)

- Notebook PCs change docking stations
⇒ MAC address changes
- Alternative: Membership implied by MAC protocol type field. VLAN1 = IP, VLAN2 = LAT, ...

Ethernet



802.3

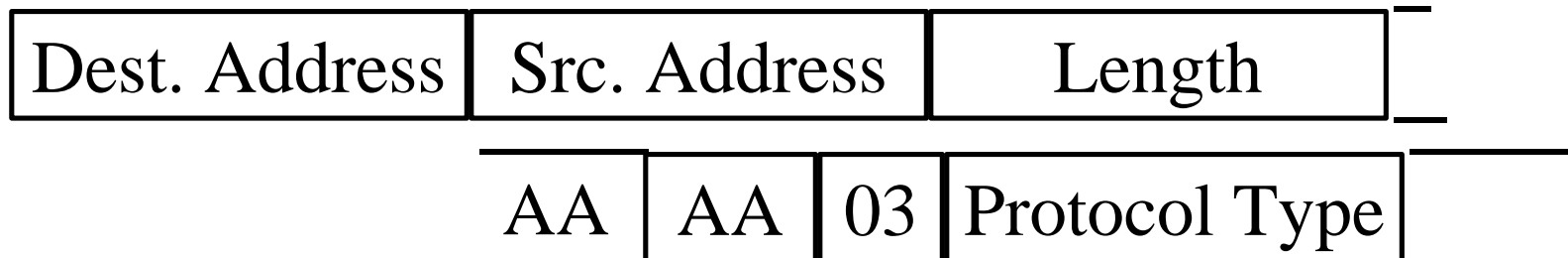

Layer-3 VLANs

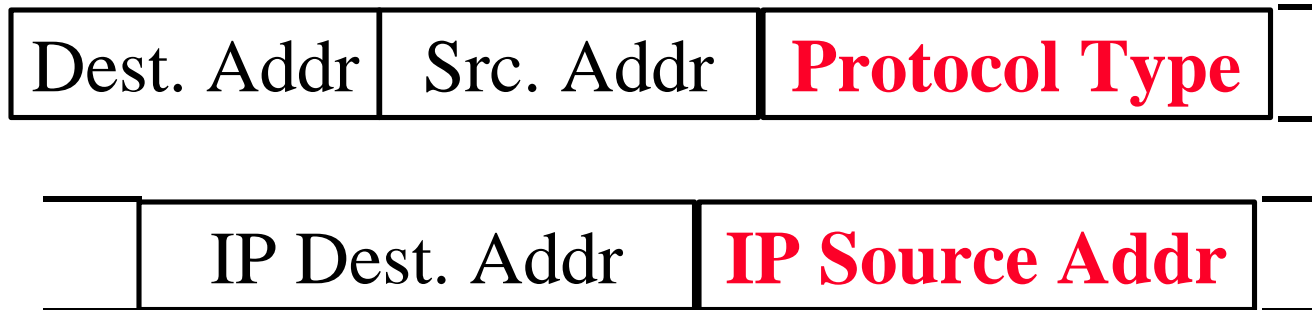

- ❑ Also known as virtual subnet
- ❑ VLAN membership implied by MAC-layer protocol type field and subnet field 123.34.*.*
- ❑ VLAN configuration is learned by the switches
- ❑ Stations do not belong to VLANs, packets do.
- ❑ Multiprotocol stations are put into multiple VLANs

Higher Layer VLANs

- ❑ Different VLANs for different applications:
 - FTP
 - Multimedia
- ❑ Service based VLANs: All workstations using Email server are on the EMAIL-VLAN, all workstations using employee database sever are on the HR-VLAN,..
- ❑ IP Multicast address based VLANs
- ❑ General policy based: VLAN membership can be based on a combination of incoming port, MAC address, subnet, or higher layer info, time of day.

VLAN Tagging

Dest. Addr	Src. Addr	VLAN Tag	Prot. Type
------------	-----------	----------	------------

- ❑ First switch adds tag containing VLAN id to all incoming packets
- ❑ Intermediate switches do not recompute the VLAN id
- ❑ Last switch removes tags from all outgoing packets
- ❑ Tag is not swapped at every hop like VC Id or labels

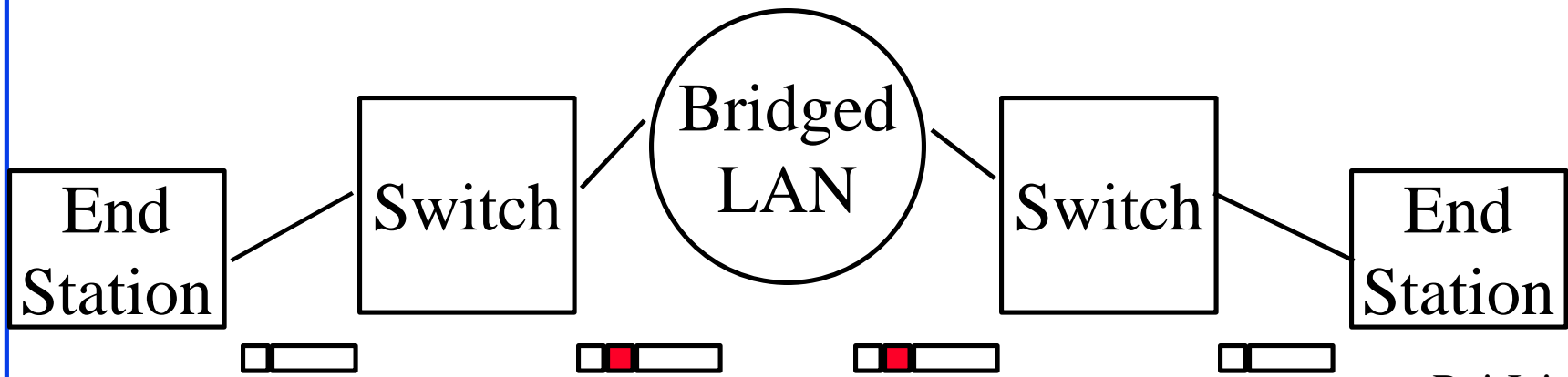

Synonyms

- Tag
- Label
- Mark
- Sticker
- Brand

IEEE 802.1Q: Features

- ❑ Allows up to 4095 VLANs
- ❑ Allows port based, MAC address based, and higher-layer VLANs
- ❑ Upward compatible with existing VLAN-unaware hubs and bridges
- ❑ Supports both shared-media and switched LANs
- ❑ Allows mixing legacy bridges and VLAN-aware bridges
- ❑ Retains plug and play mode of current LAN bridges

Features (Cont)

- ❑ Extends 802.1p priority mechanism to priority based on VLAN membership
- ❑ Allows priority associated with each VLAN
- ❑ VLAN-based priority takes precedence over other priority considerations
- ❑ Allows signaling priority information on non-priority (CSMA/CD) LANs
- ❑ Allows both local/universal MAC addresses
- ❑ Operation with/without explicit VLAN header in the frame

Features (Cont)

- ❑ Supports static and dynamic configurations for each VLAN
- ❑ Allows intermixing different IEEE 802 MACs and FDDI
- ❑ Allows signaling source routing information on CSMA/CD LANs
- ❑ Each VLAN is a subset of a "single" physical spanning tree
Does not preclude future extensions to multiple spanning trees

Features (Cont)

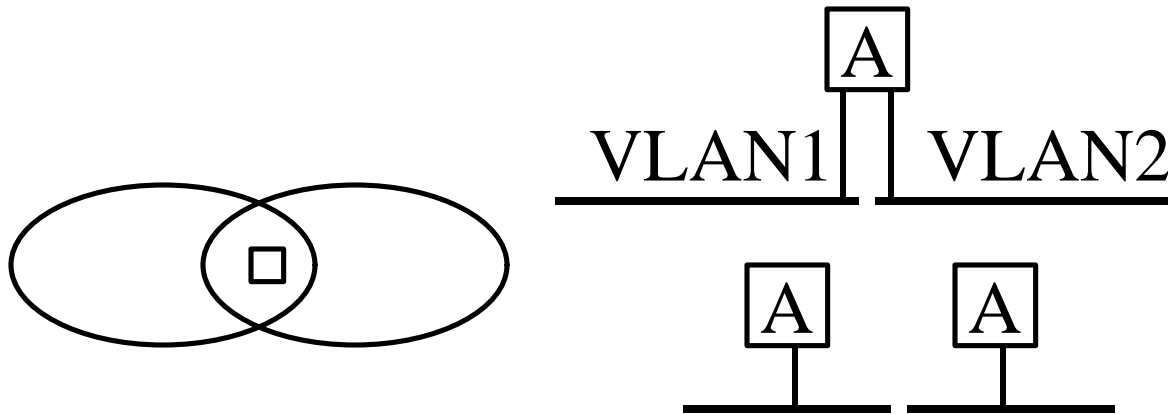

❑ Overlapping VLANs:

- Multiple stations with same individual address
- One station with multiple interfaces using the same address
- Restriction: One station or interface per VLAN

Tagging Rules

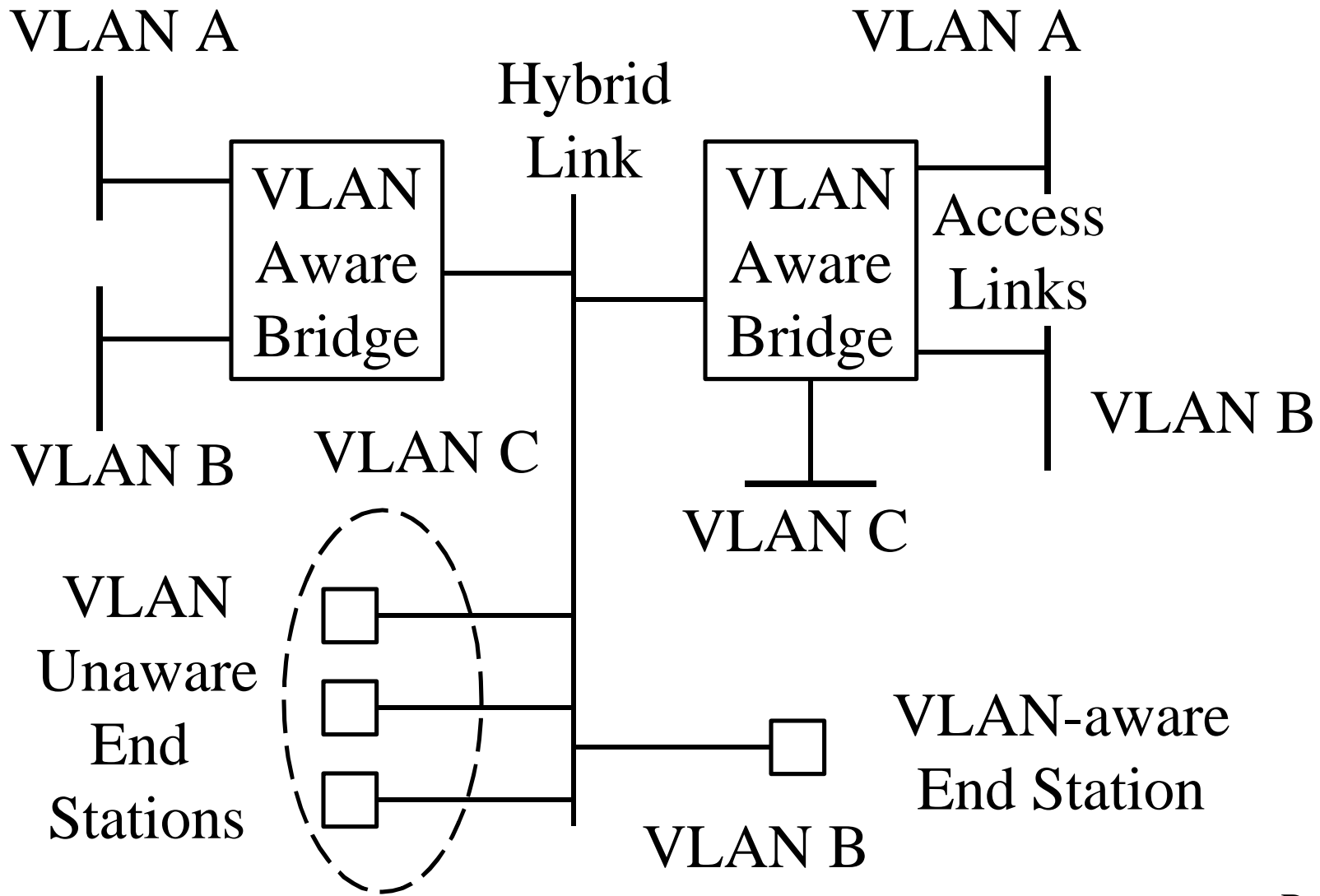

Tagging Rules (Cont)

- ❑ On a given LAN segment for a given VLAN, all frames should be either implicitly or explicitly tagged.
- ❑ Different VLANs on the same segment may use different options.
- ❑ Access Link: Contain VLAN unaware devices
All frames on access links are untagged
- ❑ Hybrid Link: Contains both VLAN-aware and VLAN-unaware devices
 - All frames for some VLANs are tagged
 - All frames for other VLANs are untagged

Tagged Frame Format

□ Tag Header:



□ Ethernet Frame:

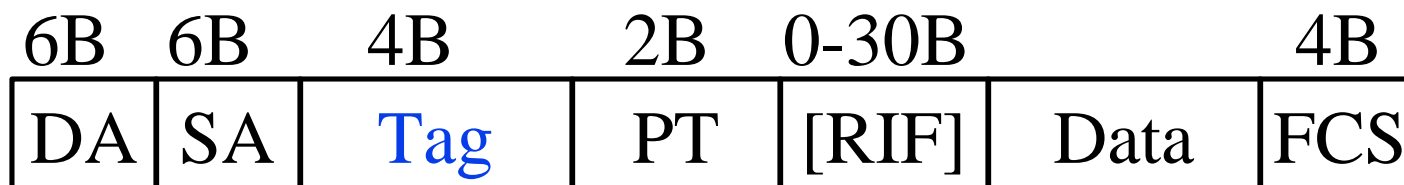

□ 802.3 Frame:

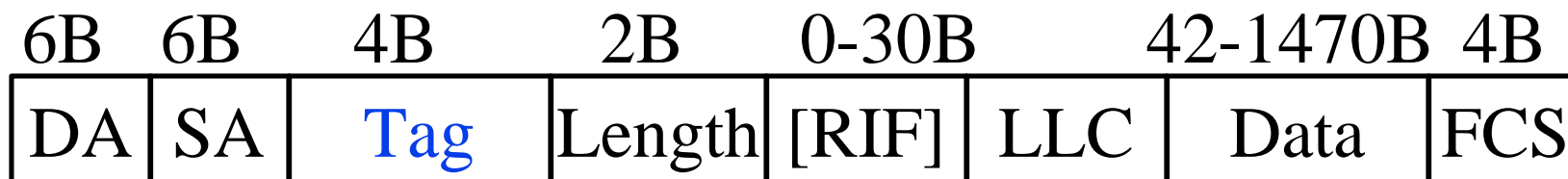

Frame Format (Cont)

- ❑ TPID = Tag Protocol ID
- ❑ CFI = Canonical Format Indicator
 - = Bit order of address info in TR/FDDI frames
 - = Presence/absence of RIF in 802.3/Ethernet frames
- ❑ RIF = Routing Information Field
 - New routing type: 01 = Transparent frame
⇒ No routing info.
- ❑ DA = Destination Address, SA = Source Address
PT = Protocol Type, LLC = Logical Link Control
FCS = Frame Check Sequence
- ❑ Largest data size = 1470 on 802.3

Frame Format (Cont)

□ Token Ring:

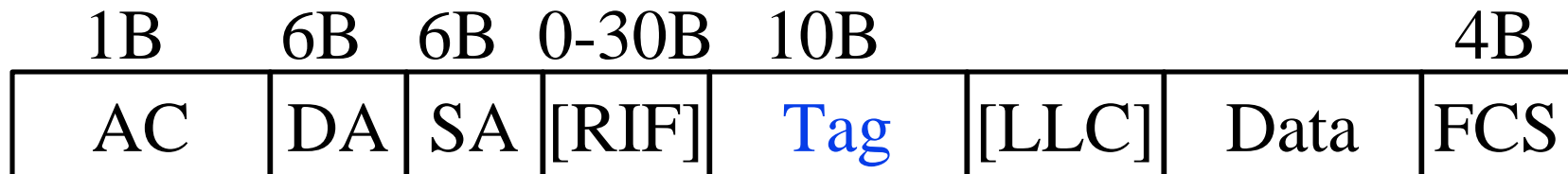

□ FDDI:

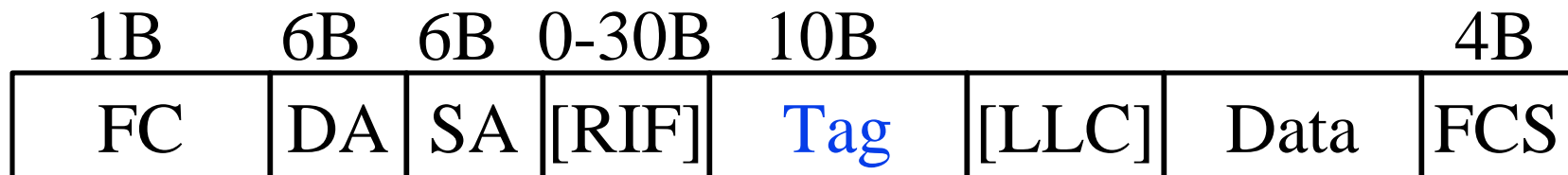

GVRP

- ❑ GARP VLAN registration protocol
- ❑ GARP = Generic attribute registration protocol
- ❑ Register VLAN Ids and port filtering modes
- ❑ Both end-stations and bridges can be GARP participants
- ❑ GARP Participants issue/revoke membership declaration \Rightarrow Creates entries in the databases
- ❑ VLAN-aware bridges propagate VLAN membership changes on all active ports

GVRP (Cont)

- ❑ VLAN-aware end stations can "source prune" traffic for VLANs that have no other members
- ❑ Initially, all ports on all bridges are set to a default "Port VLAN ID"

GMRP in VLANs

- ❑ Original GMRP is designed for one LAN
⇒ One one context or base spanning tree context
- ❑ With VLANs, multicast addresses are registered a particular VLAN context
⇒ Filtering behavior in a VLAN does not affect other VLANs

VLAN Filtering Database

- ❑ Two Types of Entries:
 - VLAN Registration entries
 - Group Registration entries
- ❑ Both types can static or dynamic
 - Static VLAN Entries: via Management
 - Dynamic Filtering Entry:
 - ❑ via learning or registration
 - ❑ Learnt entries are aged out
- ❑ Port Map for each VLAN: Whether frames should be tagged or untagged

Communication Between VLANs

- ❑ Need routers
- ❑ Can use 1-armed VLAN-aware router
- ❑ VLAN-aware switches can route between VLANs
- ❑ Such switches can be placed in the core, in the edges, or everywhere

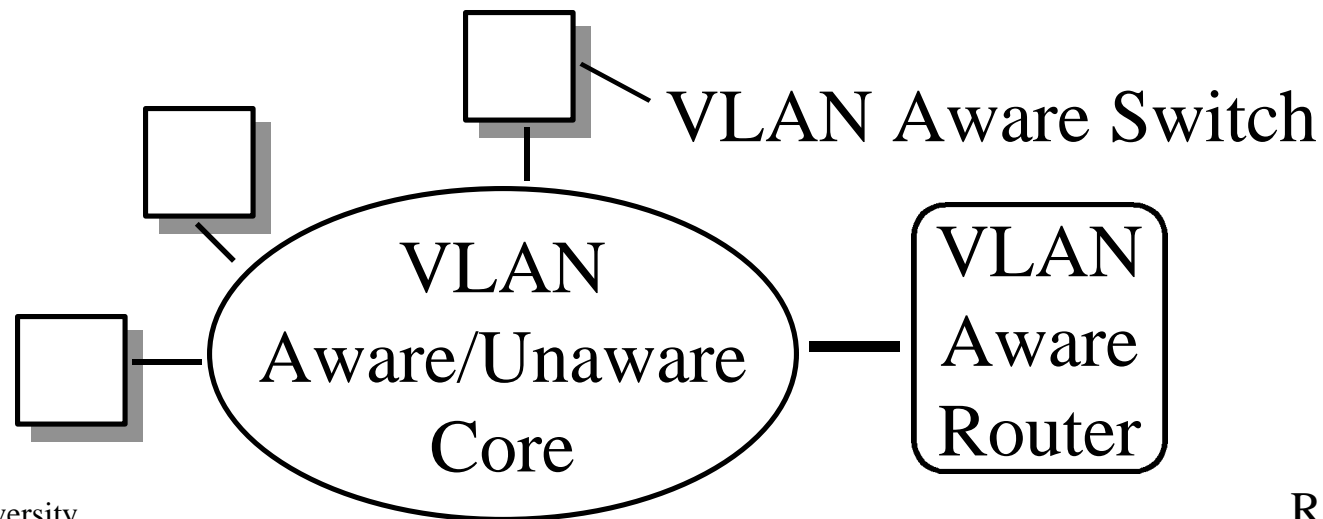

Summary

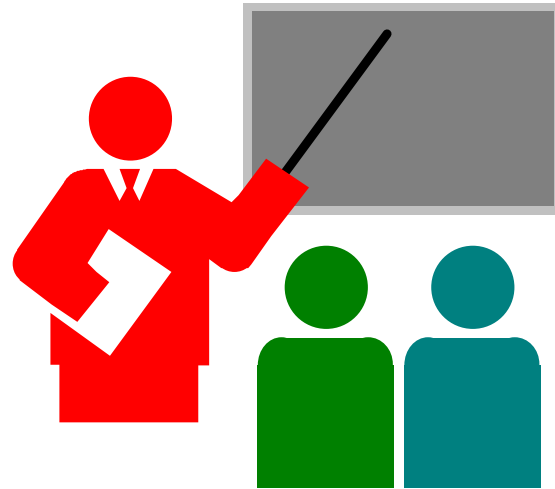

- ❑ Virtual LANs \Rightarrow Location independent LAN Groups
- ❑ Layer-1, Layer-2, Layer-3, higher layer VLANs
- ❑ IEEE 802.1Q allows both explicit and implicit tagging
- ❑ Need routing between VLANs

References

- ❑ For a detailed list of references, see http://www.cis.ohio-state.edu/~jain/refs/lsw_refs.htm
- ❑ Email list: p8021-request@hepnrc.hep.net
Mail archive: <http://www.hep.net/mail/p8021.html>
- ❑ Draft Standard for Virtual Local Area Networks, IEEE P802.1Q/D6, May 16, 1997.

Other Related Standards

- Traffic Class Expediting and Dynamic Multicast Filtering, IEEE P802.1p/D6, April 28, 1997.
- 802.1D MAC bridges
- 802.1G Remote MAC Bridging
- 802.1H Ethernet V2.0 and 802 bridging

Current Schedule

7/17/97 Priority and Multicasting on LANs

7/22/97 **No Class**

7/24/97 Virtual LANs

7/29/97 Gigabit Ethernet

7/31/97 Quiz 2 (No MBone transmission)

8/5/97 Residential broadband: Cable Modems, xDSL

8/7/97 Multimedia: Compression Standards

8/12/97 Multimedia over IP: RSVP, RTP

8/14/97 Wireless LANs and WANs

8/19/97 Quiz 3 (No MBone transmission)

Credits

This MBone transmission was made possible by:

- ❑ Mark Fullmer, OSU/UTS
- ❑ Mike Iverson, OSU/UTS
- ❑ Mike Douglas, OSU/UTS
- ❑ Jayaraman Iyer, OSU/CIS
- ❑ Sohail Munir, OSU/CIS