

# Computer Networks and the Internet

**Raj Jain**

Washington University in Saint Louis

Saint Louis, MO 63130

Jain@wustl.edu

Audio/Video recordings of this lecture are available on-line at:

<http://www.cse.wustl.edu/~jain/cse473-10/>



1. Physical Media
2. Switching: Circuit vs. Packet
3. Internet: Edge, Core
4. Network Performance Measures: Delay, Loss, Throughput
5. Protocol Layers
6. Network Security
7. History

**Note:** This class lecture is based on Chapter 1 of the textbook (Kurose and Ross) and the slides provided by the authors.

# What is a Network?

- ❑ Network: Enables data transfer among nodes
  - ❑ Generally heterogeneous nodes
  - ❑ More than 2 nodes
  - ❑ E.g., Your home or office network

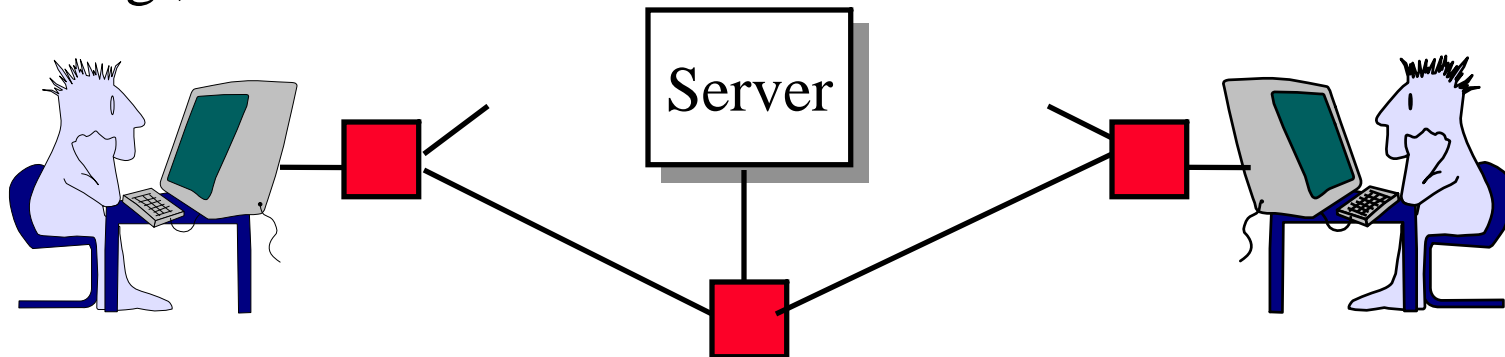

- ❑ Communication: Two nodes.
  - ❑ Link level electrical issues.



# Key Concepts



Server

- ❑ **End Systems:** Systems that are sinks or sources of data, e.g., Desktops, Laptops, Servers, Printers, Cell Phones, etc.
- ❑ **Intermediate Systems:** Systems that forward/switch data from one link to another, e.g., routers, switches
- ❑ **Hosts:** End Systems
- ❑ **Gateways:** Routers
- ❑ **Servers:** End Systems that provide service, e.g., print server, storage server, Mail server, etc.
- ❑ **Clients:** End systems that request service
- ❑ **Links:** Connect the systems.  
Characterized by transmission rate, propagation delay

# Transmission Media

## □ Guided:

- Twisted Pair
- Coaxial cable
- Optical fiber

## □ Unguided:

- Microwave
- Satellite
- Wireless

# Electromagnetic Spectrum

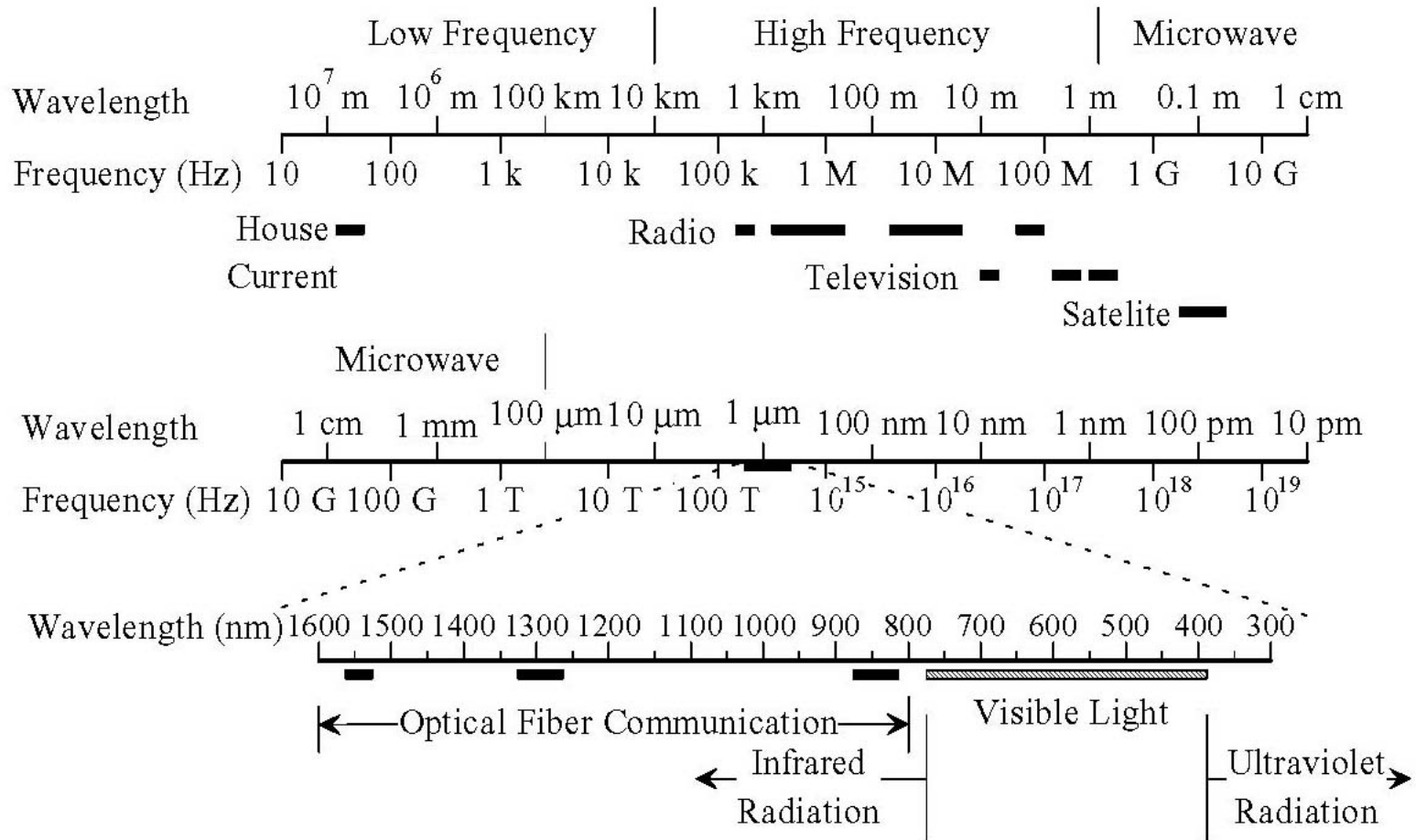

□ Infrared light is used for optical communication

# Twisted Pair (TP)

- Separately insulated
- Twisted together
- Often "bundled" into cables
- Usually installed in building during construction



(a) Twisted pair

- ❑ Twists decrease the cross-talk
- ❑ Neighboring pairs have different twist length
- ❑ Most of telephone and network wiring in homes and offices is TP.

# Shielded and Unshielded TP

- ❑ Shielded Twisted Pair (STP)
  - ❑ Metal braid or sheathing that reduces interference
  - ❑ More expensive
  - ❑ Harder to handle (thick, heavy)
  - ❑ Used in token rings
- ❑ Unshielded Twisted Pair (UTP)
  - ❑ Ordinary telephone wire
  - ❑ Cheap, Flexible
    - ⇒ Easiest to install
  - ❑ No shielding
    - ⇒ Suffers from external interference
  - ❑ Used in Telephone and Ethernet

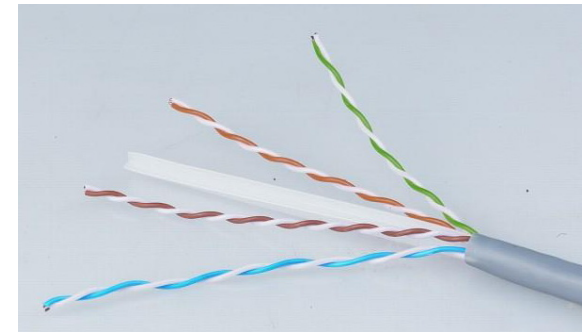
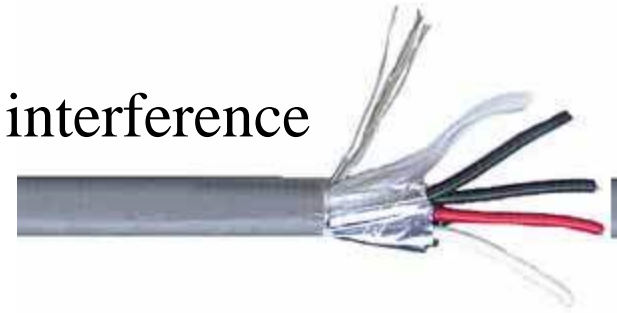



# UTP Categories

- ❑ Cat 3
  - ❑ Up to 16MHz
  - ❑ Voice grade found in most offices
  - ❑ Twist length of 7.5 cm to 10 cm
- ❑ Cat 4
  - ❑ Up to 20 MHz. Not used much in practice.
- ❑ Cat 5
  - ❑ Up to 100MHz
  - ❑ Used in 10 Mbps and 100 Mbps Ethernet
  - ❑ Twist length 0.6 cm to 0.85 cm
- ❑ Cat 5E (Enhanced), Cat 6, Cat 7, ...

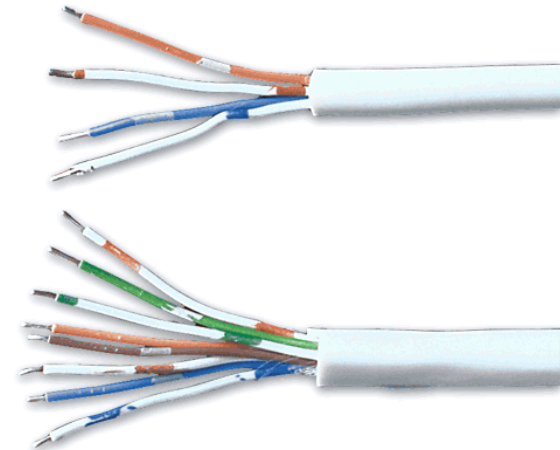

# Coaxial Cable

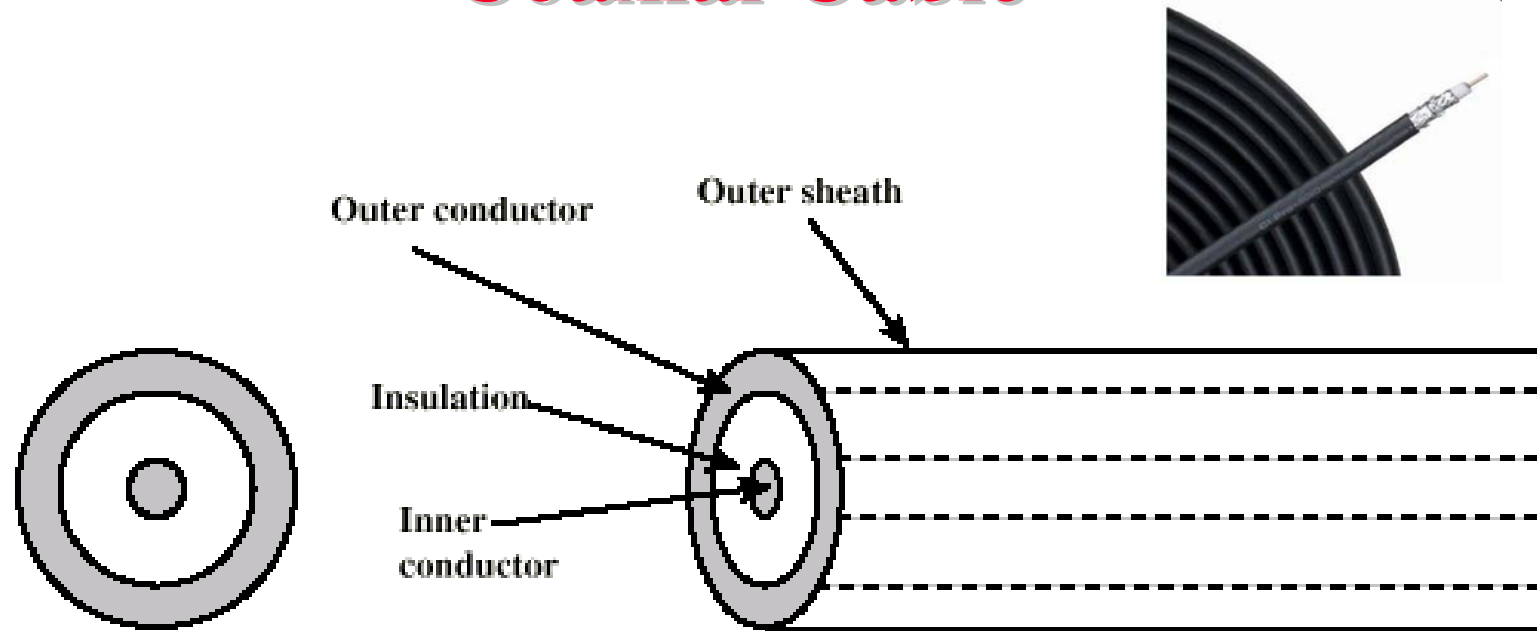

- Outer conductor is braided shield
- Inner conductor is solid metal
- Separated by insulating material
- Covered by padding

- ❑ Higher bandwidth than UTP. Up to 500 MHz.
- ❑ Used in cable TV

# Optical Communication...History

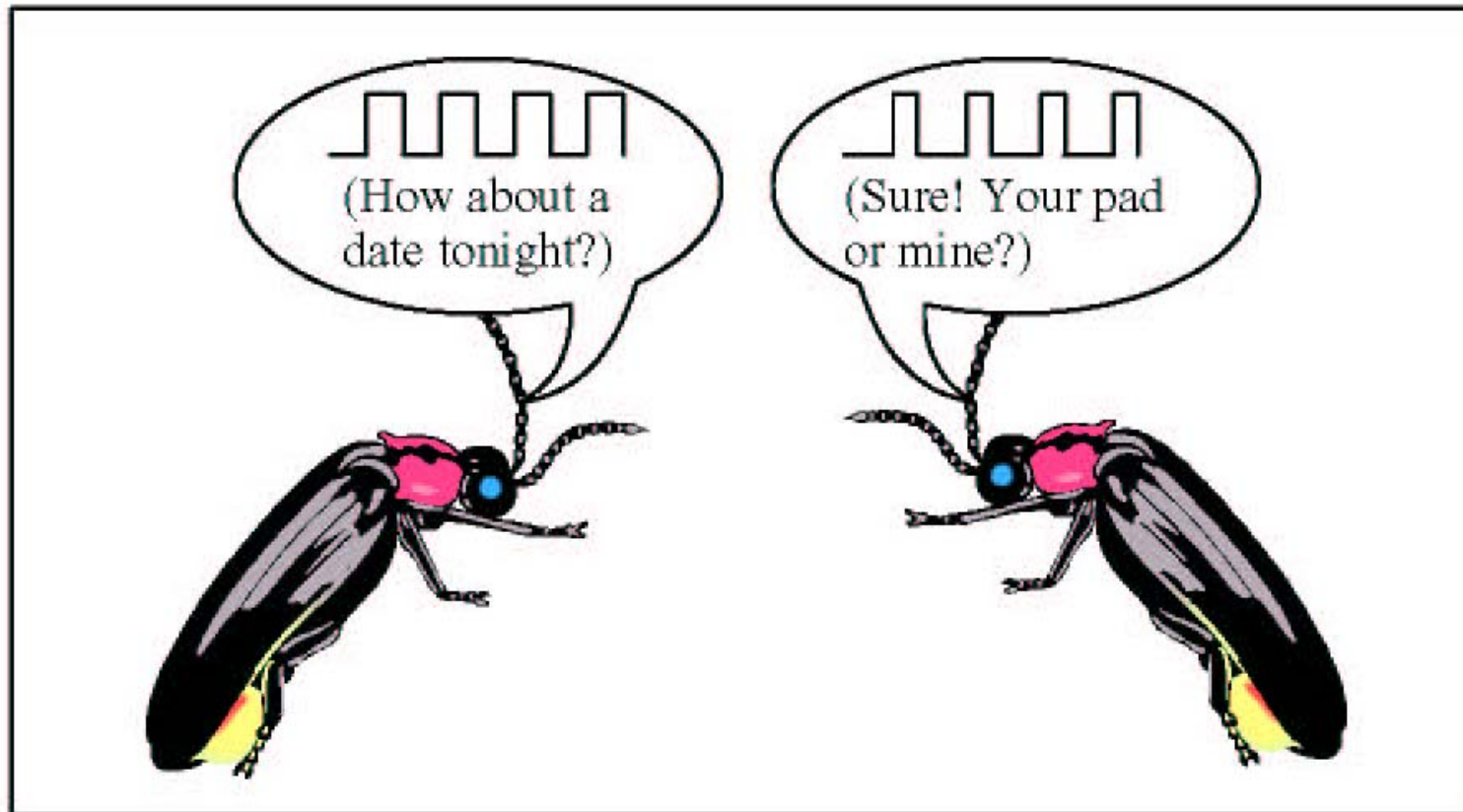

Fireflies use pulse-width modulation.

# Optical Fiber

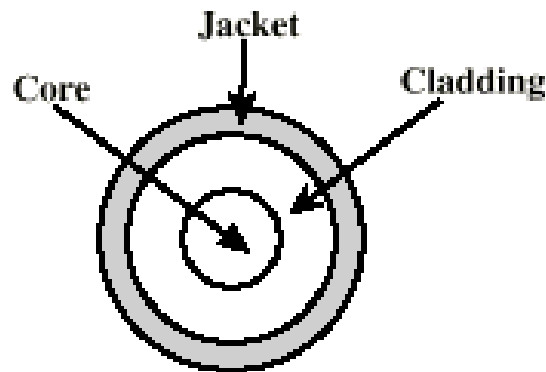

- Glass or plastic core
- Laser or light emitting diode
- Specially designed jacket
- Small size and weight

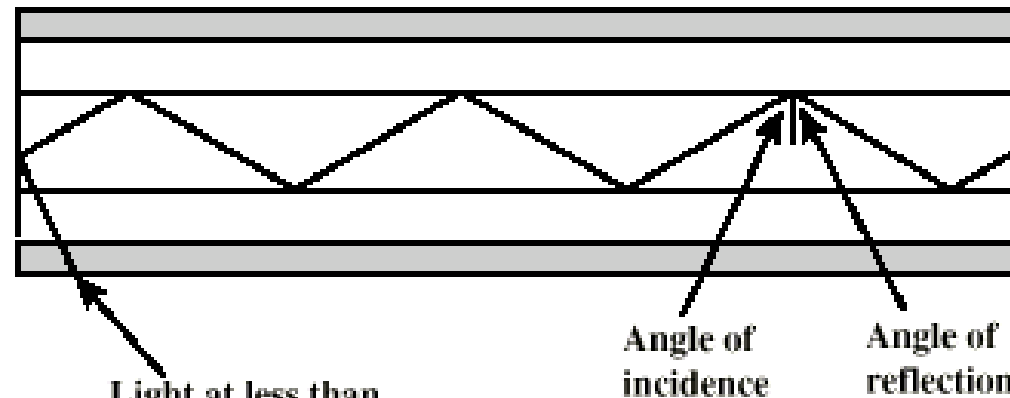

- ❑ A cylindrical mirror is formed by the cladding
- ❑ The light wave propagate by continuous reflection in the fiber
- ❑ Not affected by external interference  $\Rightarrow$  low bit error rate
- ❑ Fiber is used in all long-haul or high-speed communication
- ❑ Infrared light is used in communication

# Wireless Transmission Frequencies

- ❑ 2GHz to 60GHz
  - ❑ Terrestrial Microwave, Satellite Microwave
  - ❑ Highly directional
  - ❑ Point to point
- ❑ 30MHz to 1GHz
  - ❑ Omni-directional
  - ❑ Broadcast radio
- ❑  $3 \times 10^{11}$  to  $2 \times 10^{14}$ 
  - ❑ Infrared
  - ❑ Short distance

# Multiplexing



- ❑ How multiple users can share a link?
- ❑ Time Division Multiplexing (TDM)

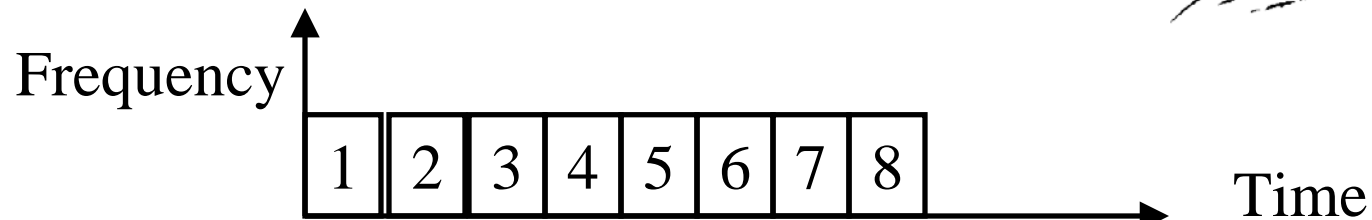

- ❑ Frequency Division Multiplexing (FDM)

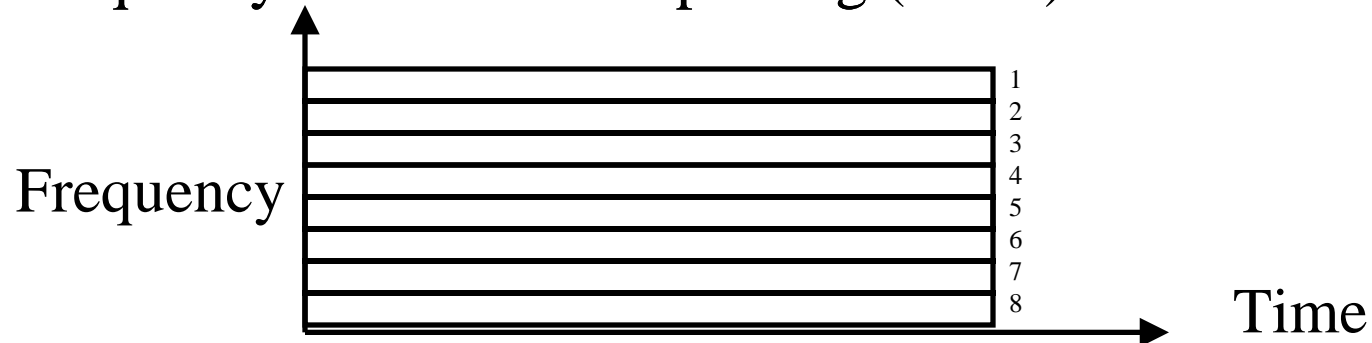

- ❑ Other multiplexing methods will be covered as needed.

# Types of Networks

- Point to point vs Broadcast

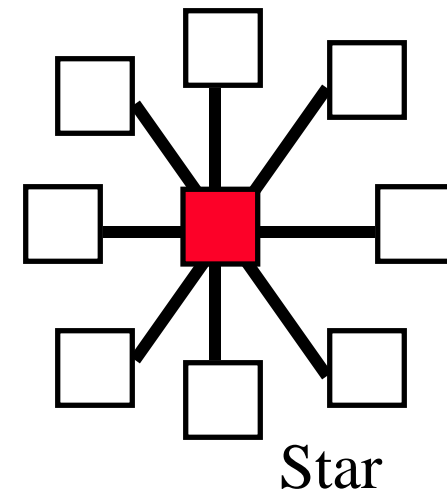
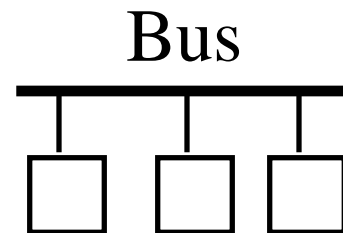
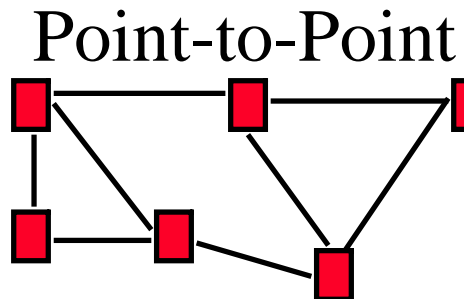

- Circuit switched vs packet switched

- Circuit: Bits repeated at every switch along the circuit path

- Packet: Packets are forwarded

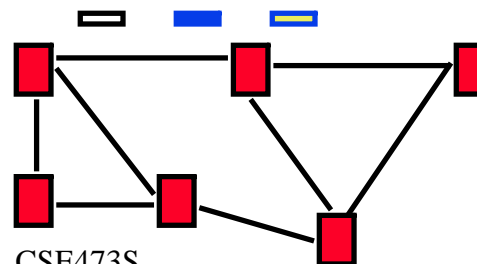
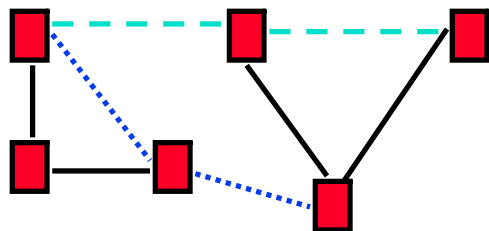

# Circuit vs. Packet Switching

	Circuit Switching	Packet Switching
Call setup	Required	Optional
Overhead during call	Minimal	Per packet overhead
State	Stateful	No state
Resource Reservation	Easy	Difficult
Quality of Service	Easy	Difficult
Sharing	By overbooking	Easy

- **Myth:** Circuits require dedicated resources  
⇒ No sharing  
True only for constant bit rate (CBR) circuits



# Types of Networks (Cont)

- ❑ Enterprise vs Telecom Networks
  - Ethernet is the most common interface in Enterprise
  - Frame relay and ATM are common in Telecom Networks
- ❑ Local Area Networks (LAN) 0-2 km, Single Ownership
- Metropolitan Area Networks (MAN) 2-50 km,
- Wide Area Networks (WAN) 50+ km
  - ❑ Originally LAN/MAN/WAN technologies were different
  - ❑ Now they are all same
- ❑ Telecom Networks:
  - ❑ Access: Between subscriber and the service provider
  - ❑ Metro: Covering a city
  - ❑ Core: Between cities

# Homework 1A

- Which networking media will you use for the following applications and why?
  1. Very large file transfer at home
  2. High-speed multiple channel video transmission at office
  3. News reading while traveling in a car

# What is Internet?

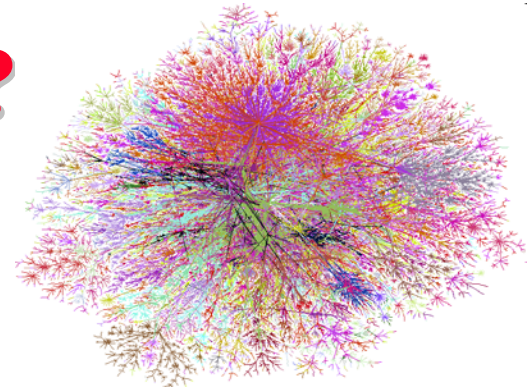
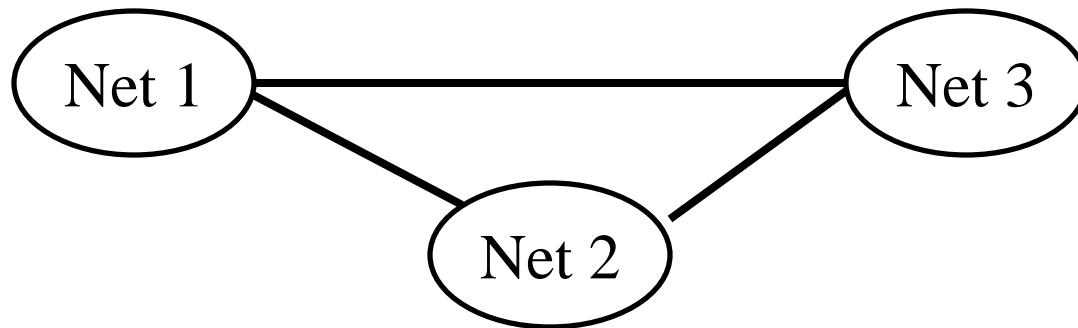

- ❑ Internet = Network connecting networks
- ❑ Approximately 600 million hosts on Internet in July 2008.
- ❑ ISP: Internet Service Provider.
  - ❑ Provide access to Internet.
  - ❑ Telecommunications (Telephone) Companies, AT&T, Verizon, Comcast, ...
  - ❑ Coffee Shops (Wi-Fi)

# Structure of the Internet



- ❑ Enterprise/Home Networks: Stub Networks. Privately owned  $\Rightarrow$  Not owned by ISP.
- ❑ Access Network: Enterprise to ISP
- ❑ Core Network: ISP's network

# Types of ISPs

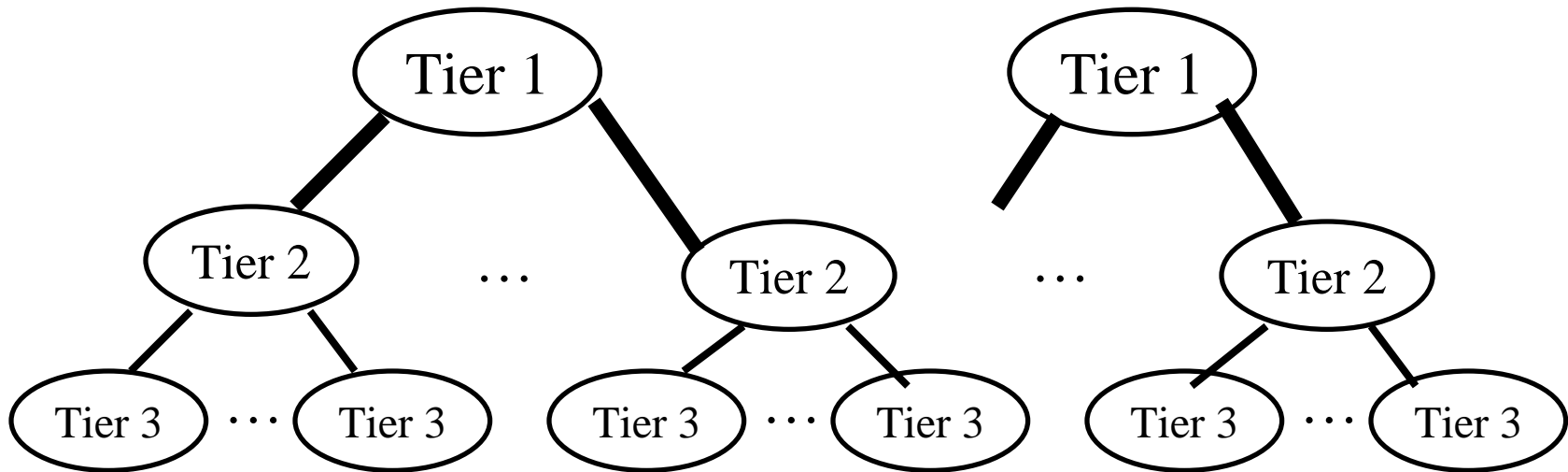

- ❑ Tier 1: Global or National, e.g., AT&T, Verizon, ...
- ❑ Tier 2: Regional
- ❑ Tier 3: Local

# Network Edge: Enterprise Networks

1. Ethernet
2. Wi-Fi

# Ethernet

- ❑ Uses UTP (Unshielded Twisted Pair)
- ❑ 10 Mbps, 100 Mbps, 1 Gbps, 10 Gbps
- ❑ Originally bus, now point-to-point (Star) topology

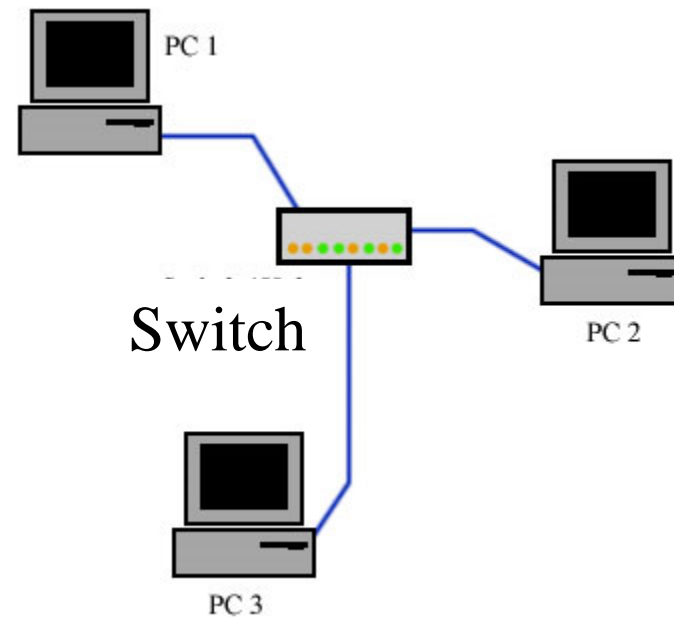
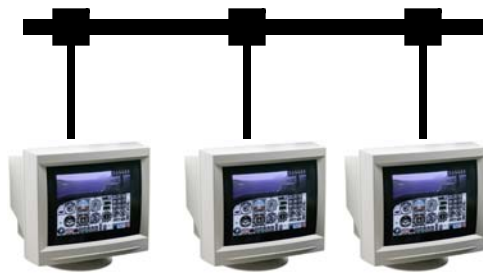

# Wi-Fi

- ❑ IEEE 802.11
- ❑ Uses 2.4 GHz and 5.8 GHz





# Access Networks

1. Dial Up
2. DSL
3. Cable
4. Fiber-To-The-Home
5. Wi-Fi
6. WiMAX

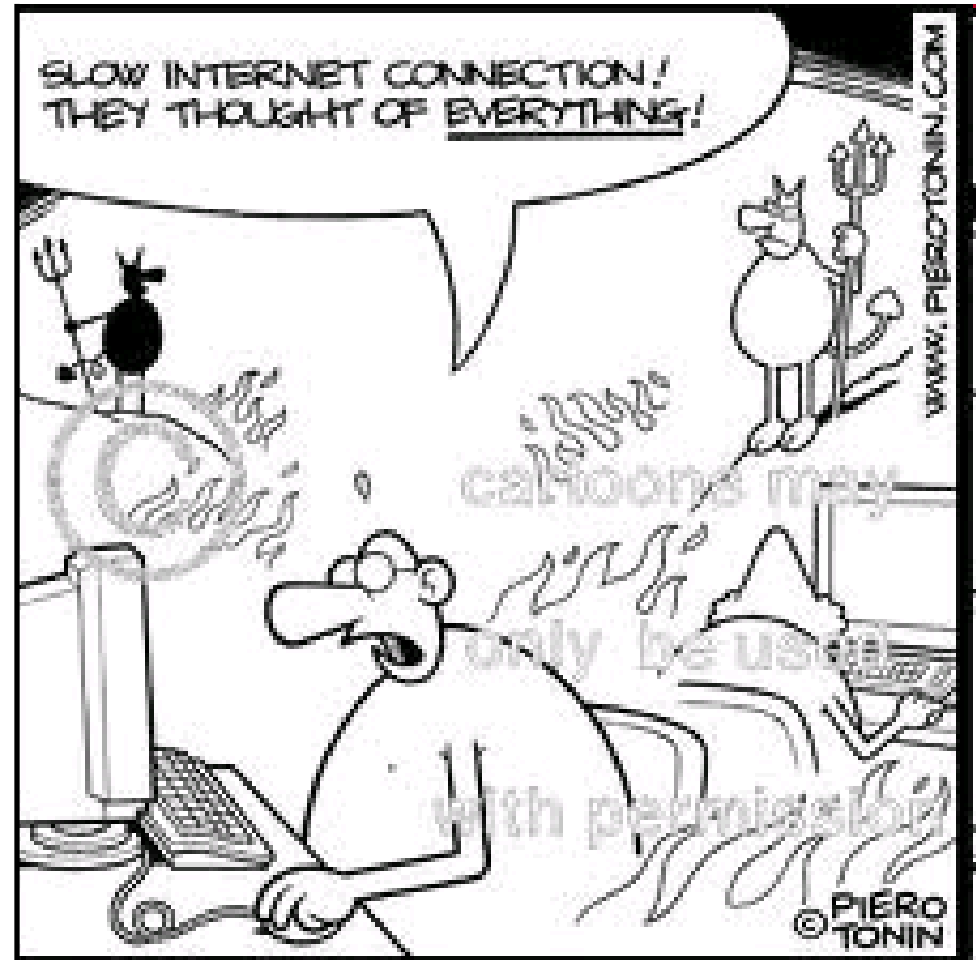

# Dial Up

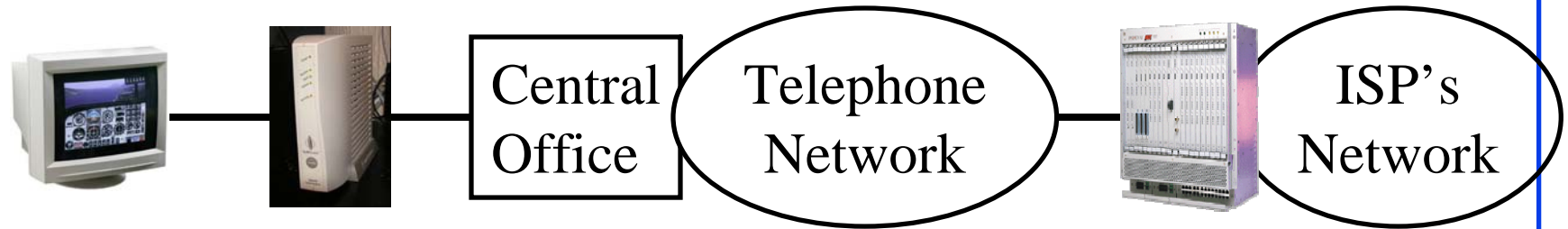

Home PC

Modem

Modems

- ❑ Modem (Modulator/Demodulator) convert electrical bits to sound waveforms for transmission over telephone network
- ❑ Telephone network designed to carry 4 kHz voice
- ❑ Up to 56 kbps
- ❑ Does not need much help from the phone company

# Bits, Hertz, and Baud

- Bits: Unit of information. Binary 0 or 1
- Bits are transmitted as pulses: E.g., Manchester encoding

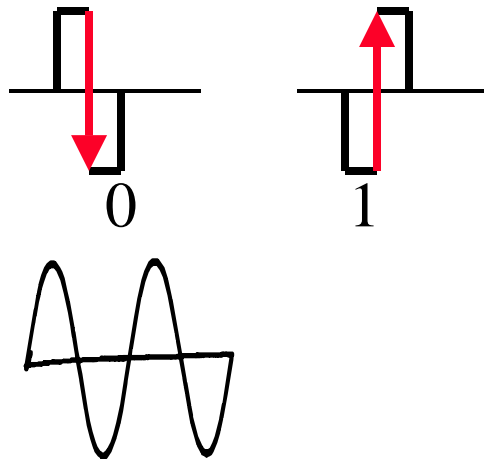

0=High-to-low transition  
1=Low-to-high transition

- Receiver design depends on the duration of smallest pulse  
1kbps  $\Rightarrow$  One bit per millisecond  $\Rightarrow$  Each pulse is  $\frac{1}{2}$  ms  
 $\Rightarrow$  2 kBaud
- The pulses become a mixture of sine waves on the medium
- Wires allow only certain frequencies  $\Rightarrow$  Hertz = cycles/second

- Bi-Level Coding:  $1=+5V$ ,  $0=0V$

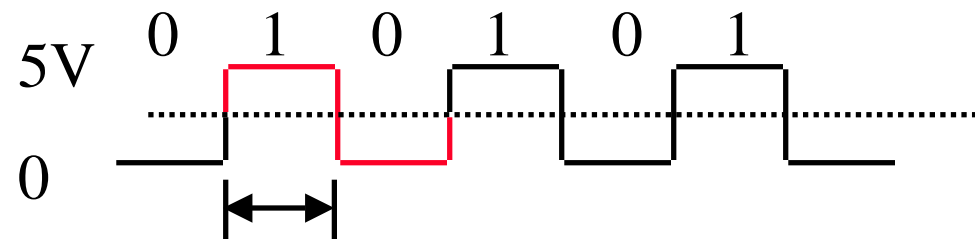

- Multi-Level Coding:  $00=-5V$ ,  $01=-1.67V$ ,  $10=+1.67V$ ,  $11=5V$

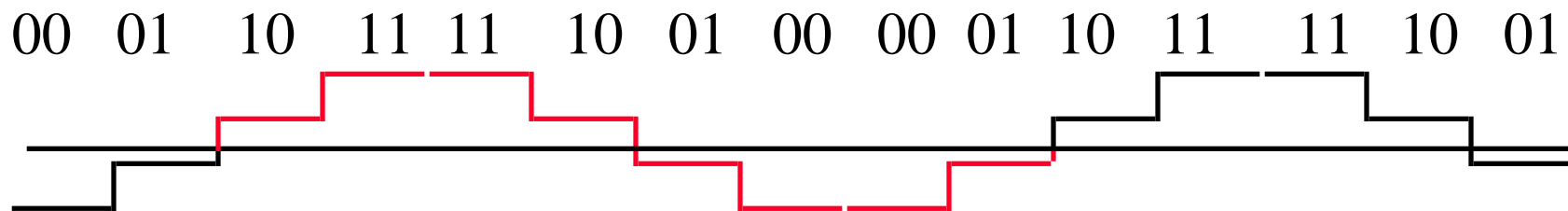

# DSL

- ❑ Digital Subscriber Line (DSL)
- ❑ Can transmit very high data rates on phone wire using special equipment at the phone company allowing higher frequency signals

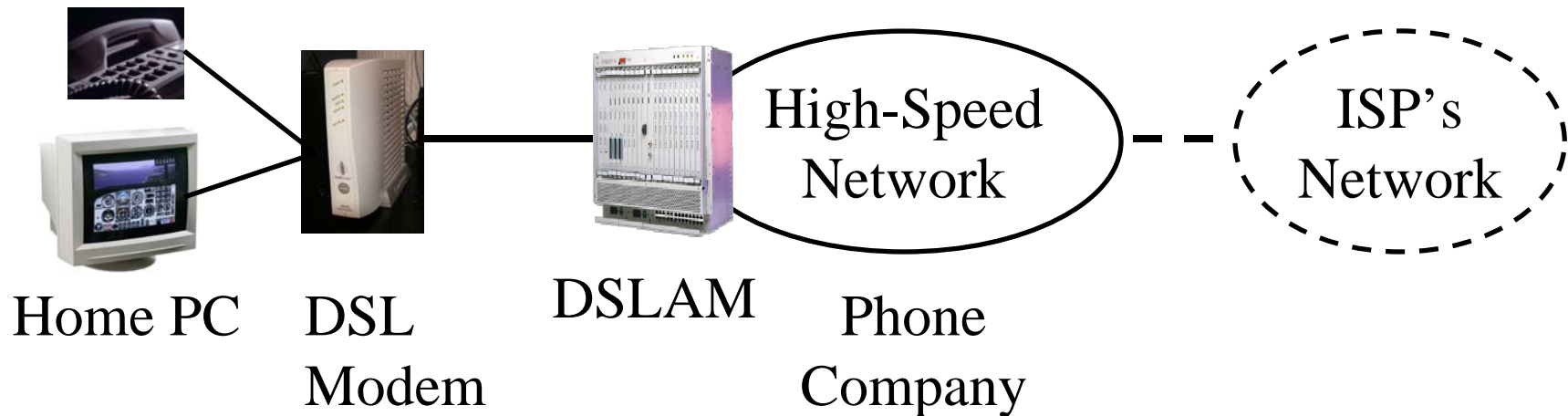

- ❑ DSL Access Multiplexer (DSLAM)
- ❑ 100 kbps - 100 Mbps

# Cable



- ❑ Cable companies have a very-high speed medium (for video transmission)
- ❑ Phone wire = 4kHz for voice  
Video Cable = 500 MHz for video  
One TV Channel = 6 MHz
- ❑ 30 Mbps down/1 Mbps up
- ❑ Fiber in the main line + Coax in tributaries  
⇒ Hybrid Fiber Coax (HFC)



Cable  
Modem

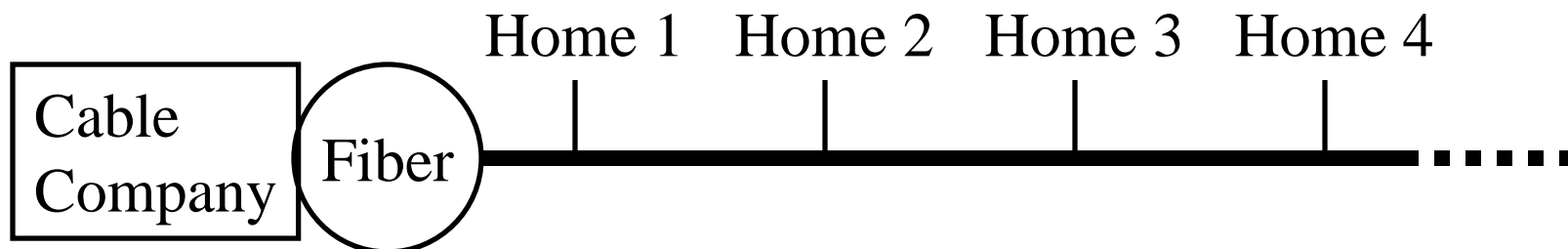

# Fiber-To-The-Home (FTTH)

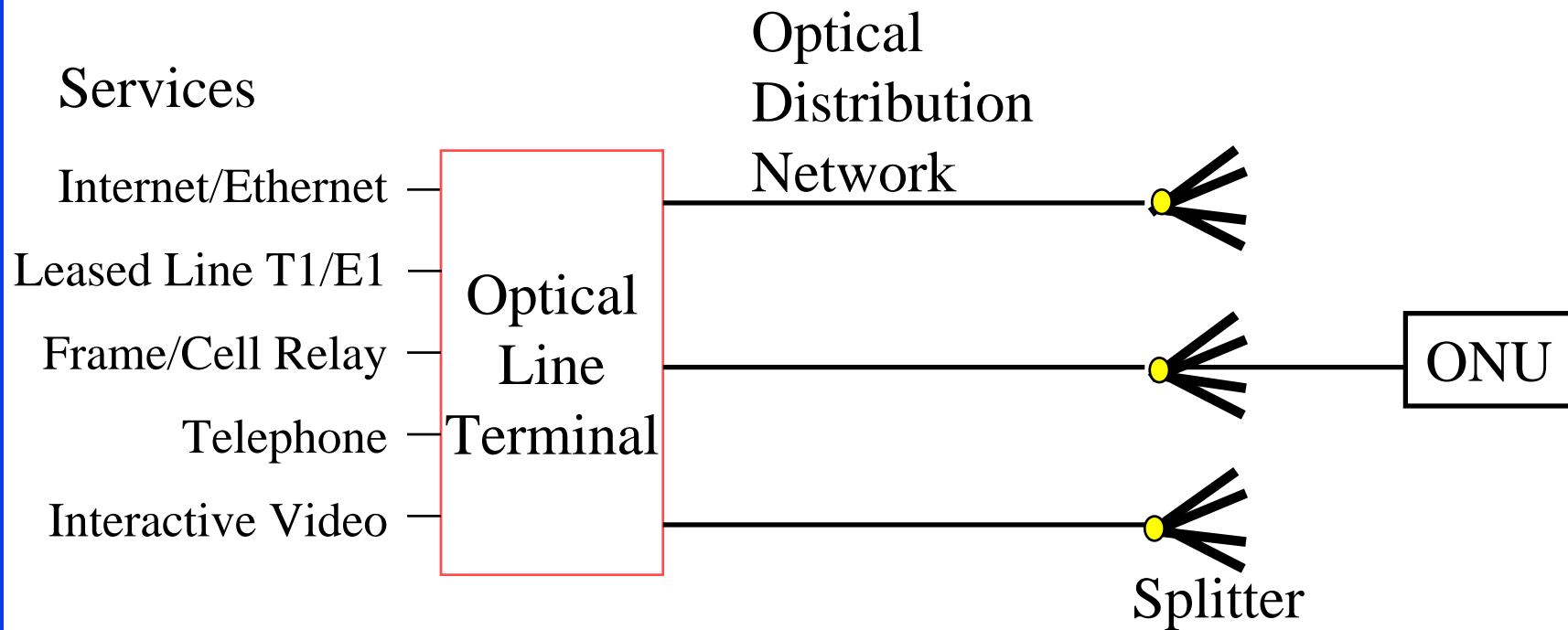

- ❑ 100+ Mbps per home. Multiple services.
- ❑ No electronic components in the distribution system  
⇒ Passive ⇒ Reliable
- ❑ Passive Optical Network (PON)

# Wireless Access Networks

- ❑ Wi-Fi hot spots
- ❑ Cellular access
- ❑ WiMAX



# WiMAX

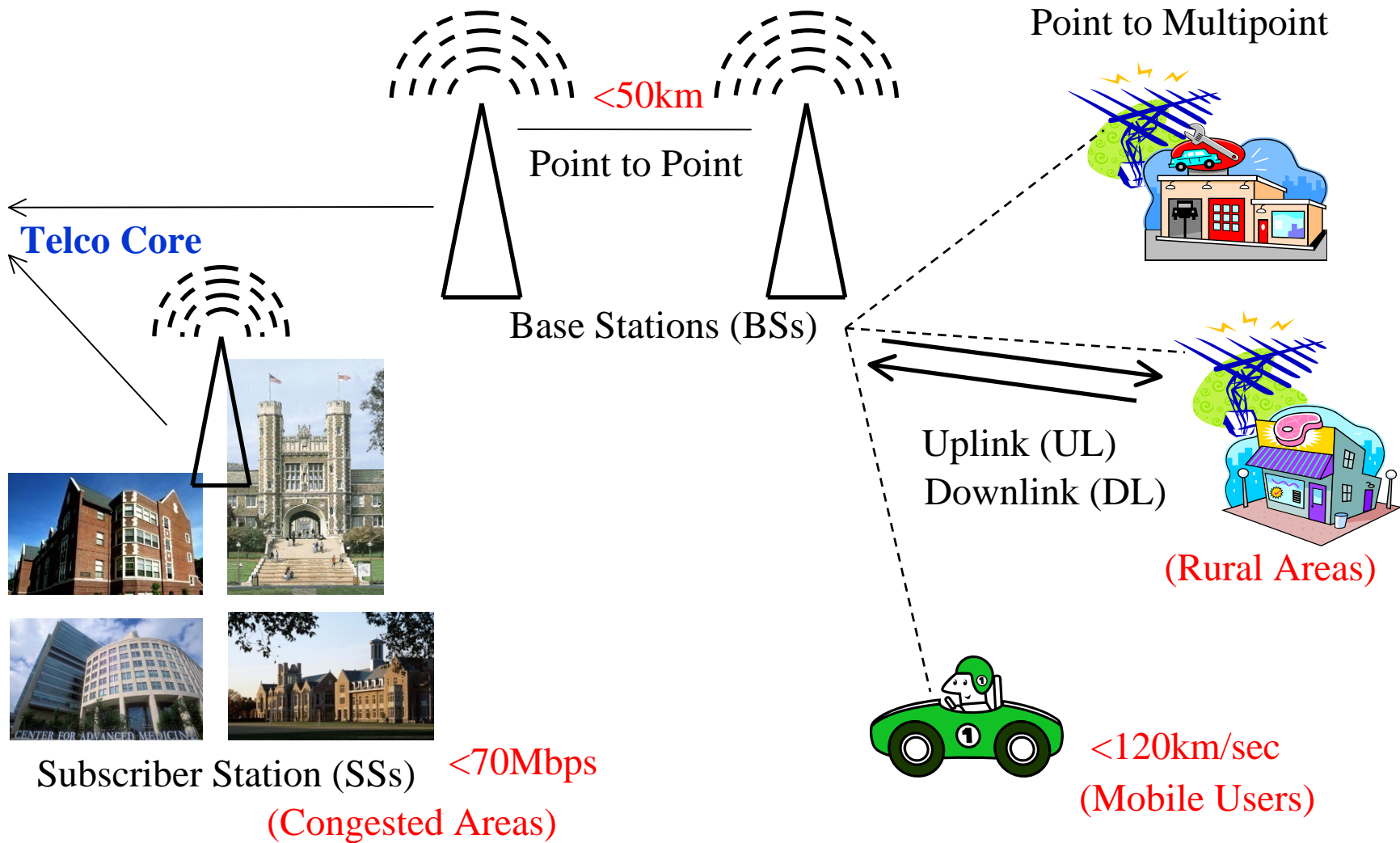

# Network Performance Measures

- Delay
- Throughput
- Loss Rate

# Delay Example (CBR Circuits)

- ❑ How long would it take to send a file of 640,000 bits from host A to host B over a circuit-switched network?
  - ❑ All links are 1.536 Mbps
  - ❑ Each link is shared by 24 users
  - ❑ 500 ms to establish end-to-end circuit
- ❑ Per User Rate =  $1536/24 = 64$  kbps
- ❑ Time to transfer =  $640\text{kb}/64\text{kb} = 10$  s
- ❑ Total time =  $.5$  s +  $10$  s =  $10.5$  s

# Packet Switching Delay

1. Processing Delay: Check packets, decide where to send, etc.
2. Queuing Delay: Wait behind other packets
3. Transmission Delay: First-bit out to last-bit out on the wire  
= Packet Length/bit rate
4. Propagation Delay: Time for a bit to travel from in to out  
= Distance/speed of signal  
Light speed =  $3 \times 10^8$  m/s in vacuum,  $2 \times 10^8$  m/s in fiber

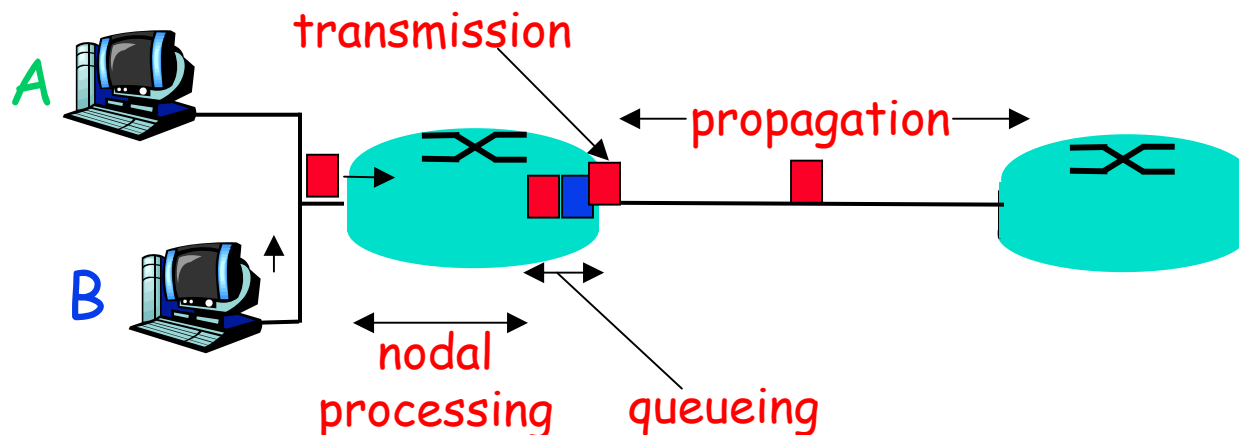

# Packet Switching Delay: Example

- ❑ 1500 Byte packets on 10 Mbps Ethernet, 1km segment
- ❑ Transmission Delay =  $1500 \times 8 / 10 \times 10^6 = 1200 \mu\text{s} = 1.2\text{ms}$
- ❑ Propagation delay =  $1000 \text{ m} / 2 \times 10^8 = 5 \mu\text{s}$

# Throughput

- ❑ Measured in Bits/Sec
- ❑ Capacity: Nominal Throughput
- ❑ Throughput: Realistic
- ❑ Bottleneck determines the end-to-end throughput



Net end-to-end capacity = 10 Mbps

Actual throughput will be less due to sharing and overhead.

# Loss Rate

- ❑ Queuing  $\Rightarrow$  Buffer overflow
- ❑ Bit Error Rate on the link
- ❑ Lost packets are retransmitted by the previous node or the source

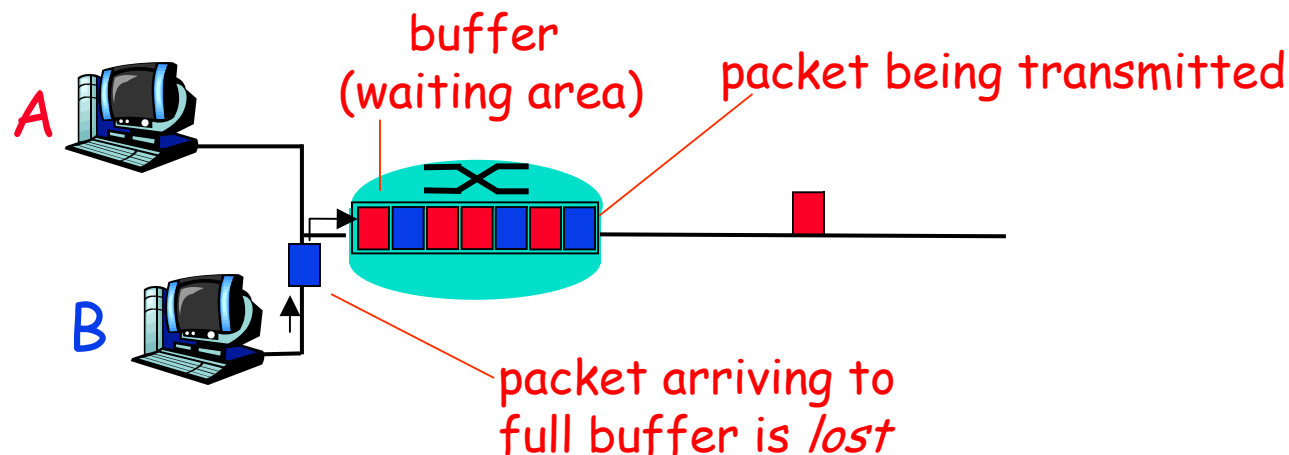

# Homework 1B

P5: Consider two hosts, A and B, connected by a single link of rate  $R$  bps. Suppose that the two hosts are separated by  $m$  meters, and suppose the propagation speed along the link is  $s$  meters/sec. Host A is to send a packet of size  $L$  bits to Host B.

- A. Express the propagation delay,  $d_{prop}$  in terms of  $m$  and  $s$
- B. Determine the transmission time of the packet  $d_{trans}$  in terms of  $L$  and  $R$ .
- C. Ignoring processing queuing delays, obtain an expression for the end-to-end delay
- D. Suppose Host A begins to transmit the packet at time  $t=0$ . At time  $t=d_{trans}$  where is the last bit of the packet?
- E. Suppose  $d_{prop}$  is greater than  $d_{trans}$ . At time  $t=d_{trans}$ , where is the first bit of the packet?
- F. Suppose  $d_{prop}$  is less than  $d_{trans}$ , at time  $t=d_{trans}$ , where is the first bit of the packet
- G. Suppose  $s=2.5 \times 10^8$  m/s,  $L=240$  bits, and  $R=56$  kbps,. Find the distance  $m$  so that  $d_{prop}$  equals  $d_{trans}$ .



# Protocol Layers

- ❑ Problem: Philosophers in different countries speak different languages. The Telex system works only with English.

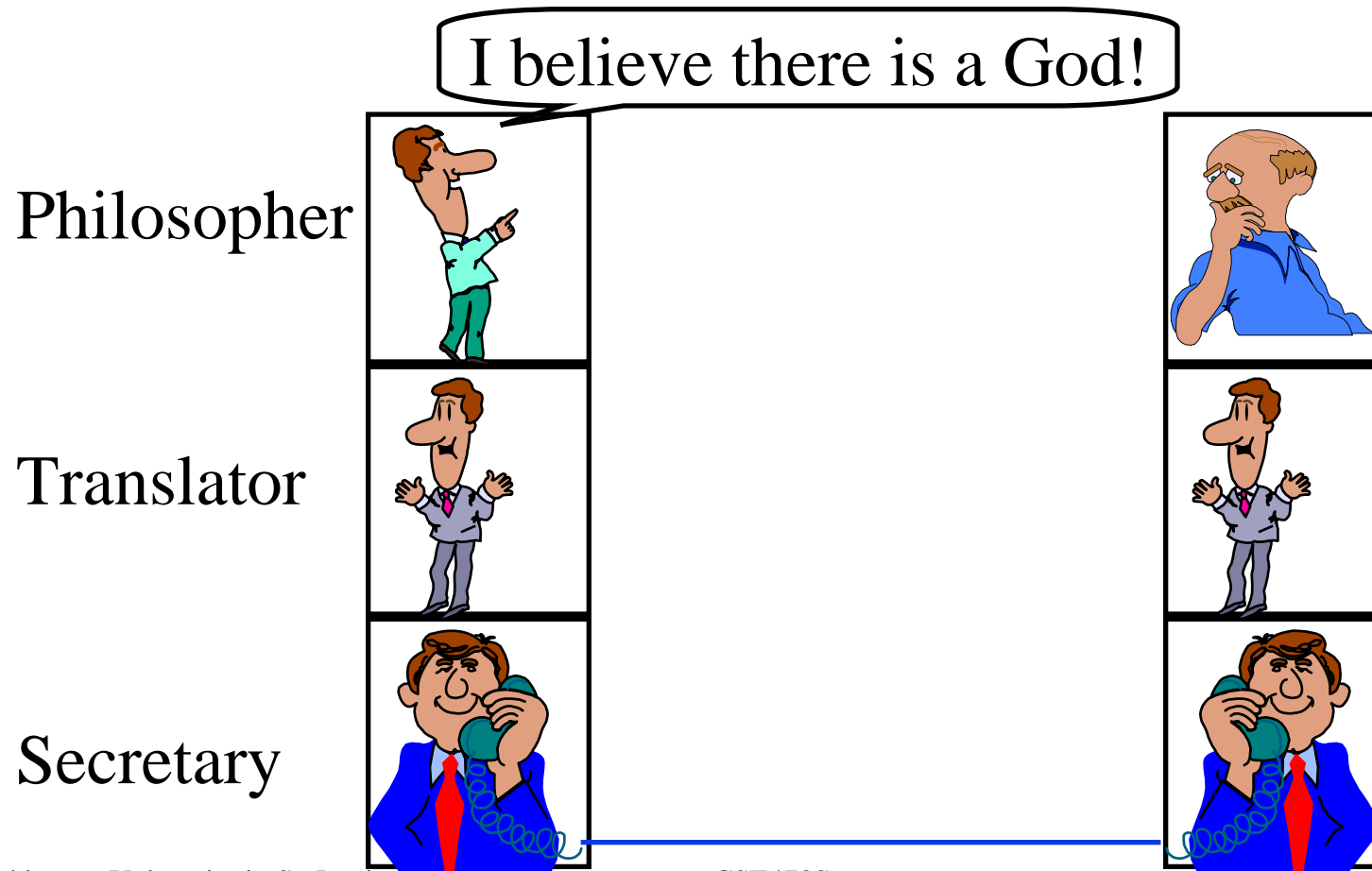

# ISO/OSI Reference Model

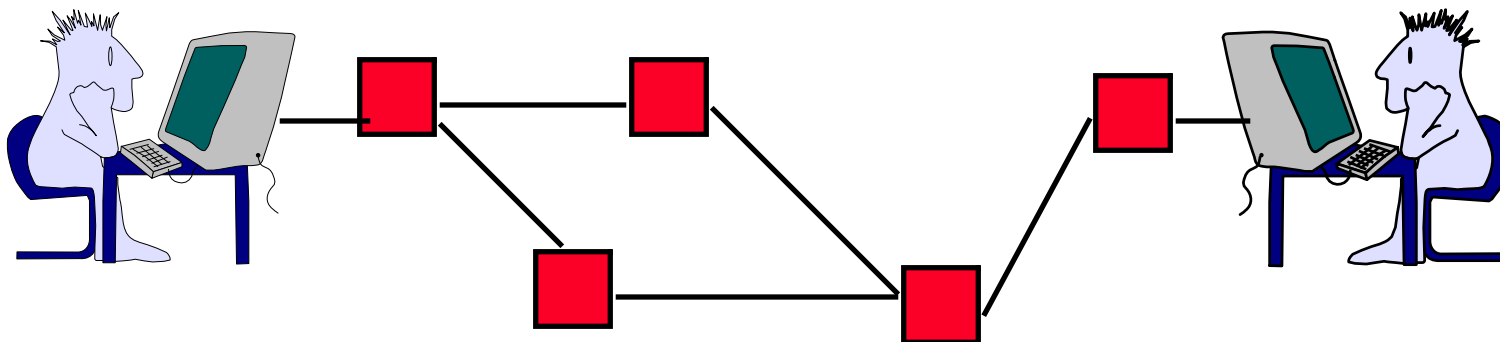
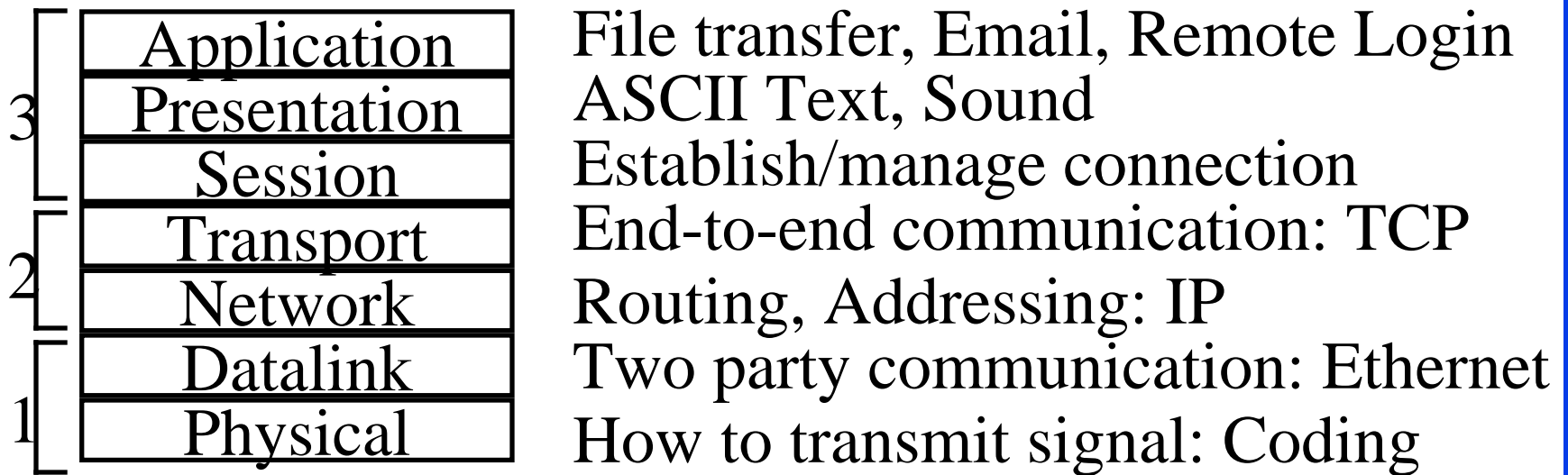

# Service and Protocol Data Units

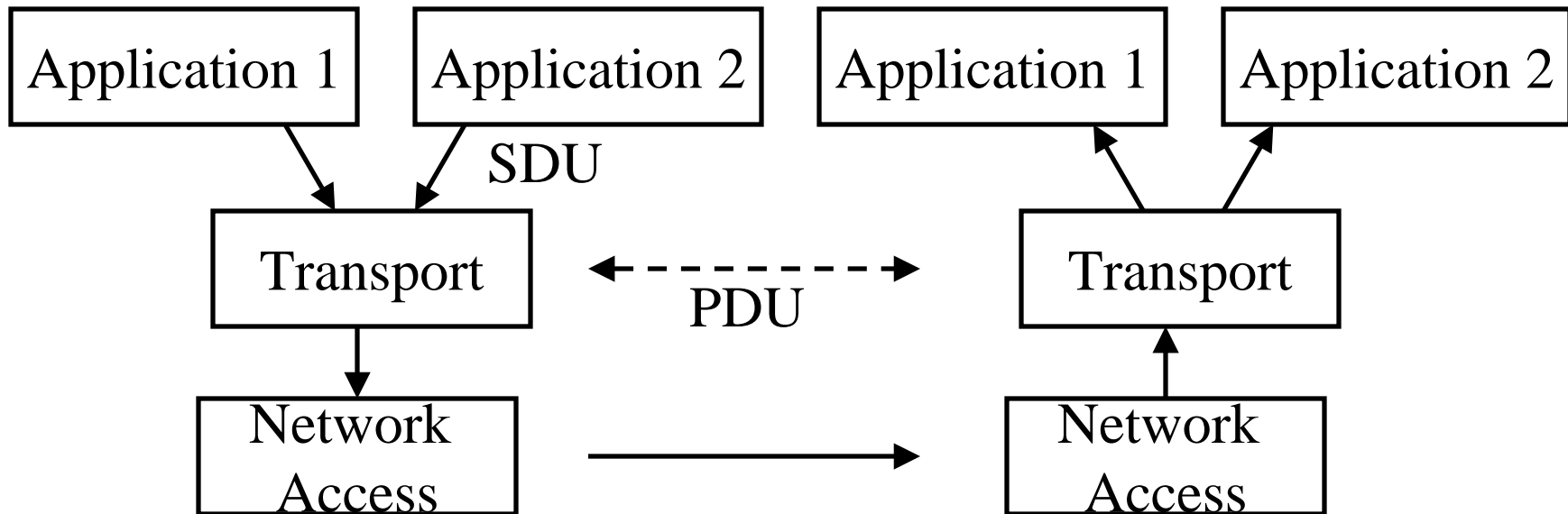

- ❑ Service Access Points (SAPs)
- ❑ Service Data Units (SDUs)
- ❑ Protocol Data Units (PDUs)

# Service Data Unit (SDU)

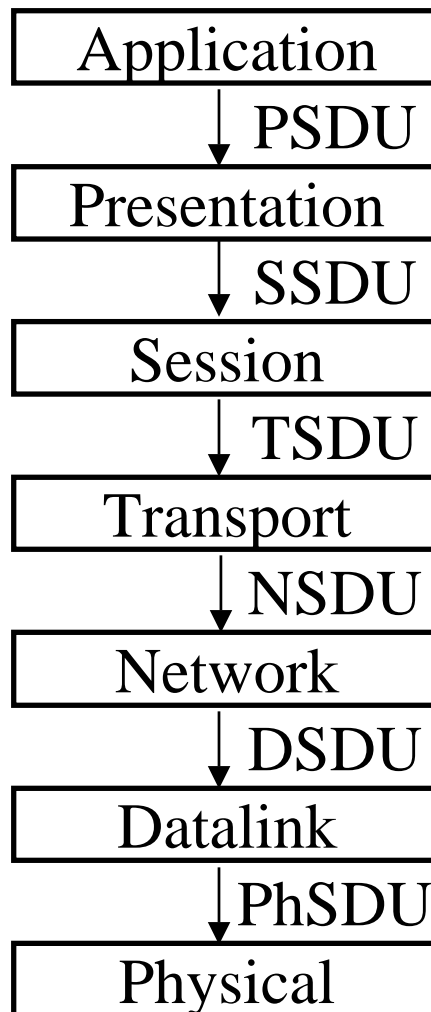

# Protocol Data Unit (PDU)

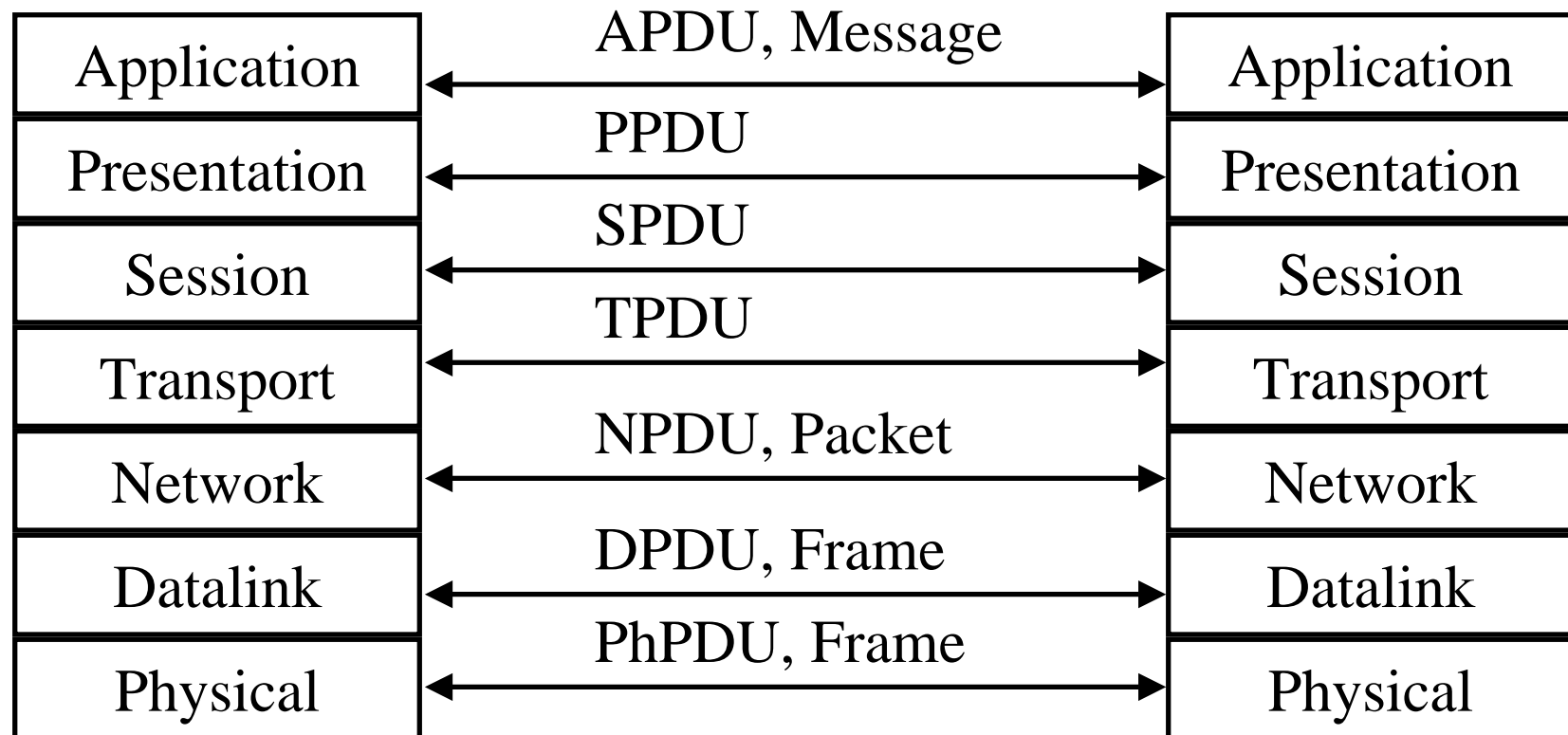

# Service Primitives

- Indication = Interrupt

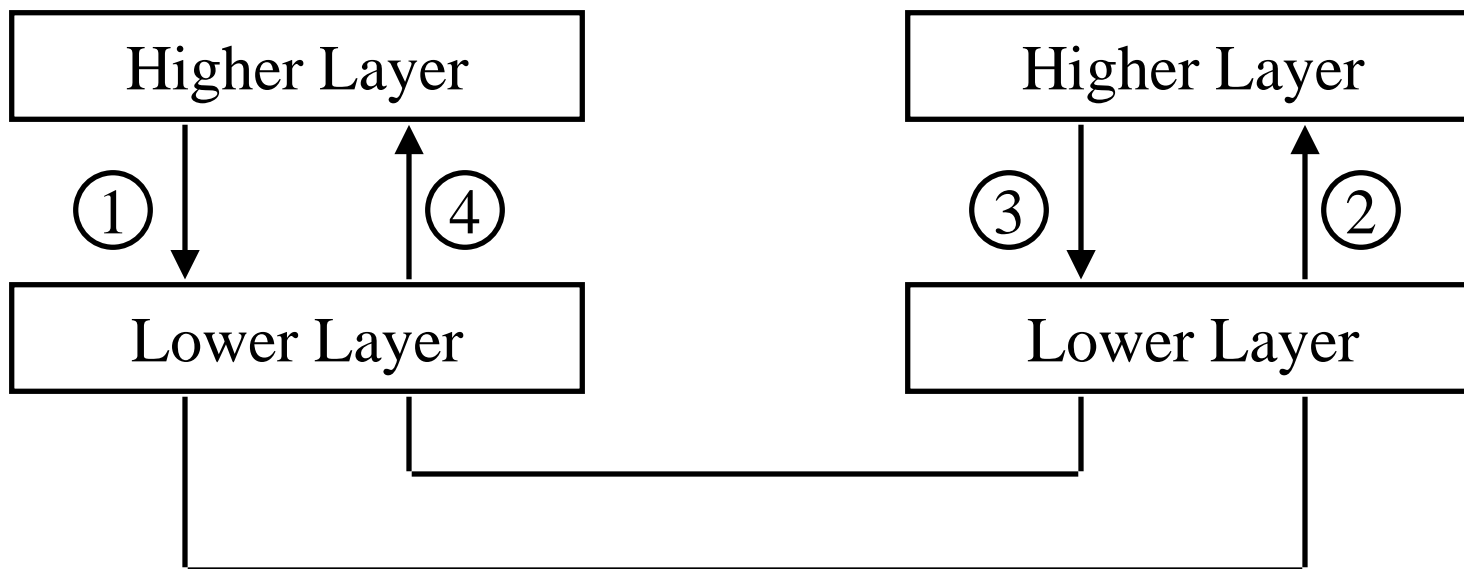

1. Request

2. Indication

3. Response

4. Confirm

Unconfirmed service: No confirmation or response

# TCP/IP Reference Model

- ❑ TCP = Transport Control Protocol
- ❑ IP = Internet Protocol (Routing)

TCP/IP Ref Model      TCP/IP Protocols

Application	FTP	Telnet	HTTP
Transport	TCP		UDP
Internetwork	IP		
Host to Network	Ethernet	Point-to-Point	Packet Radio
Physical	Coax	Fiber	Wireless

# OSI vs TCP/IP

<b>OSI</b>	<b>TCP/IP</b>
Application	Application
Presentation	
Session	
Transport	Transport (host-to-host)
Network	Internet
Data Link	Network Access
Physical	Physical



# OSI vs TCP Reference Models

- ❑ OSI introduced concept of services, interface, protocols. These were force-fitted to TCP later  
⇒ It is not easy to replace protocols in TCP.
- ❑ In OSI, reference model was done before protocols. In TCP, protocols were done before the model
- ❑ OSI: Standardize first, build later  
TCP: Build first, standardize later
- ❑ OSI took too long to standardize. TCP/IP was already in wide use by the time.
- ❑ OSI became too complex.
- ❑ TCP/IP is not general. Ad hoc.

# PDU in TCP/IP Architecture

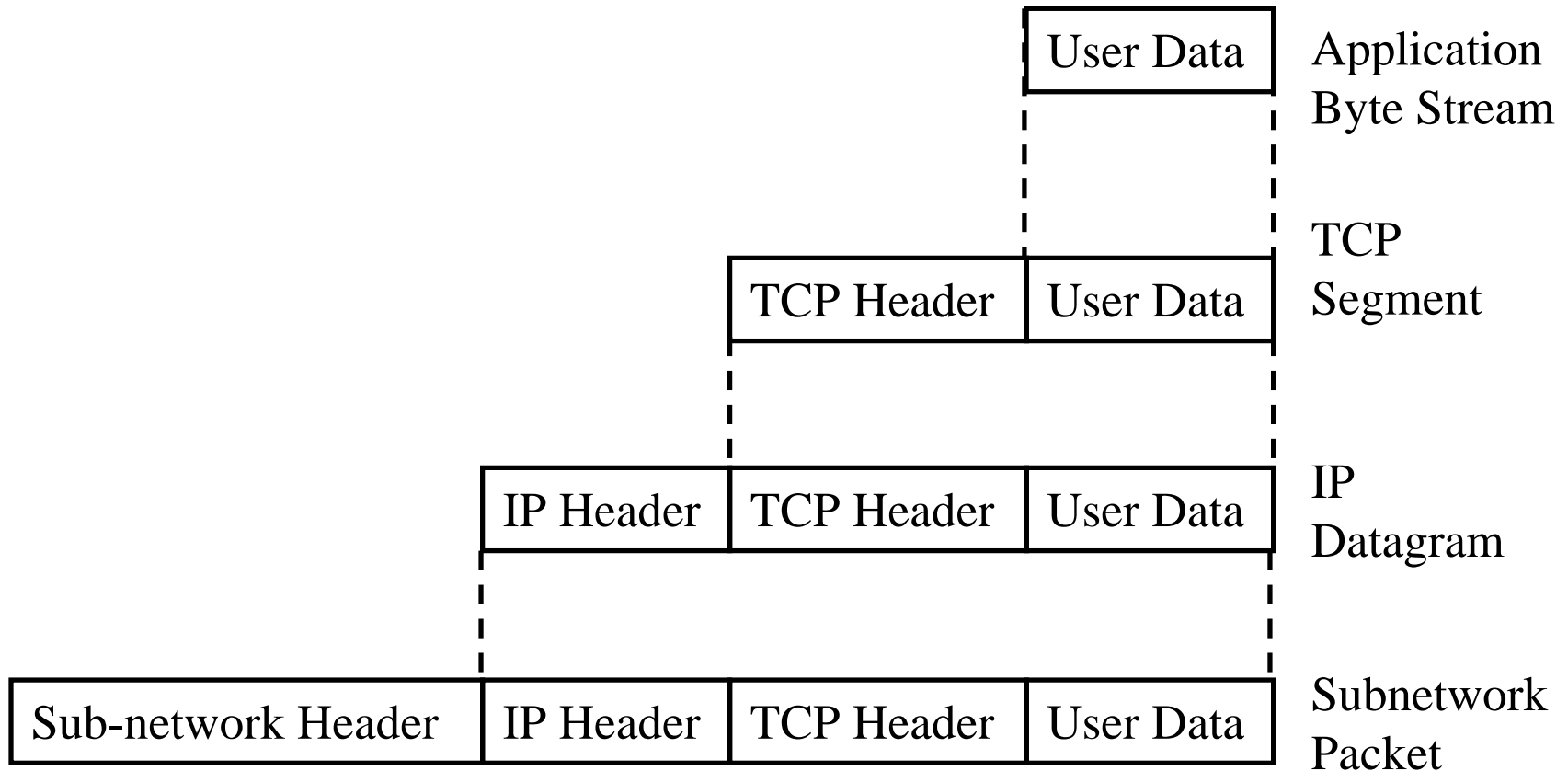

# TCP/IP Applications

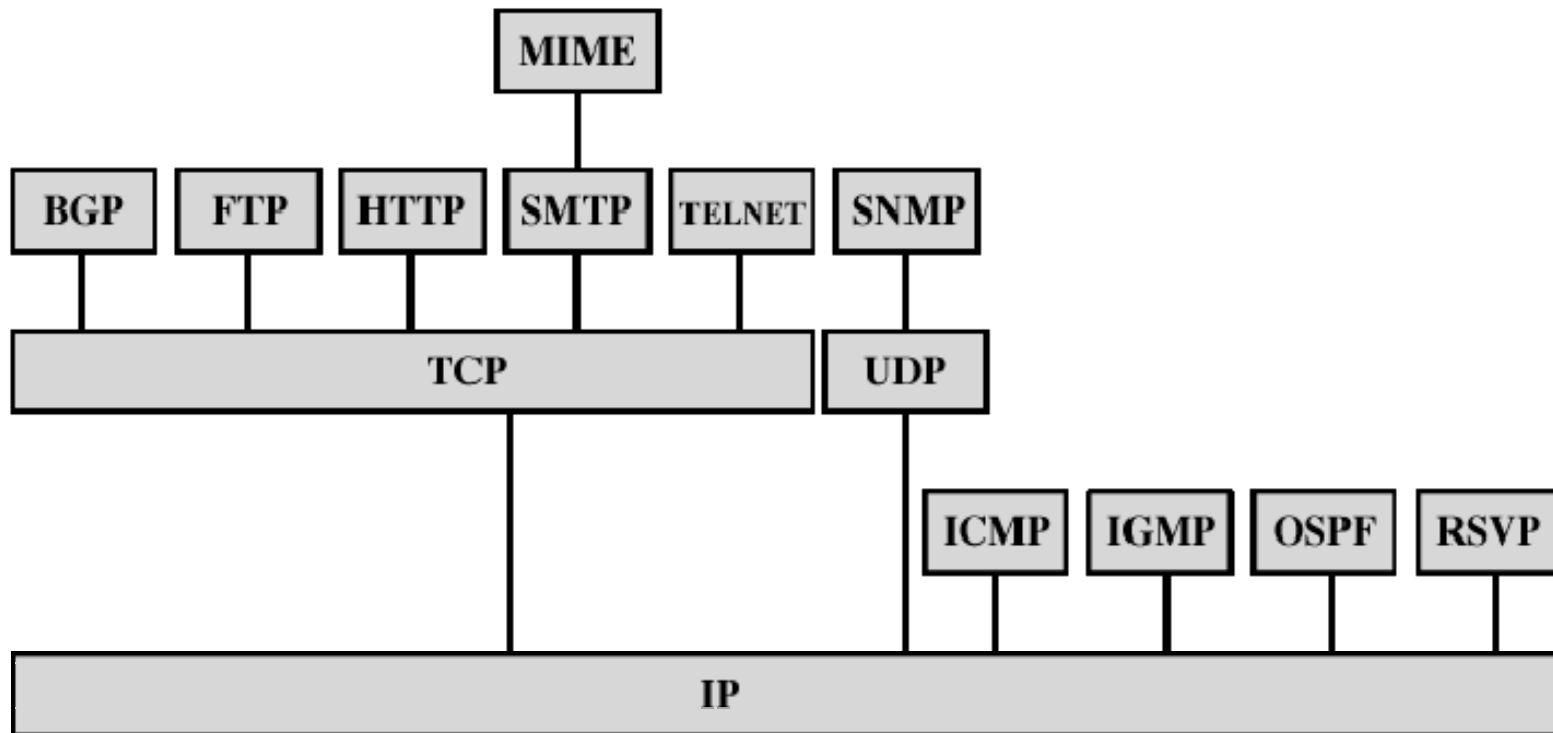

**BGP** = Border Gateway Protocol  
**FTP** = File Transfer Protocol  
**HTTP** = Hypertext Transfer Protocol  
**ICMP** = Internet Control Message Protocol  
**IGMP** = Internet Group Management Protocol  
**IP** = Internet Protocol  
**MIME** = Multi-Purpose Internet Mail Extension

**OSPF** = Open Shortest Path First  
**RSVP** = Resource ReSerVation Protocol  
**SMTP** = Simple Mail Transfer Protocol  
**SNMP** = Simple Network Management Protocol  
**TCP** = Transmission Control Protocol  
**UDP** = User Datagram Protocol

# Network Security

- ❑ Security Components
- ❑ Types of Malware
- ❑ Types of Attacks
- ❑ Buffer Overflows
- ❑ Distributed DoS Attacks

# Security Components

- ❑ **Confidentiality**: Need access control, Cryptography, Existence of data
- ❑ **Integrity**: No change, content, source, prevention mechanisms, detection mechanisms
- ❑ **Availability**: Denial of service attacks,
- ❑ Confidentiality, Integrity and Availability (**CIA**)



# Types of Malware

- ❑ **Viruses**: Code that *attaches* itself to programs, disks, or memory to propagate itself.
- ❑ **Worms**: Installs copies of itself on other machines on a network, e.g., by finding user names and passwords
- ❑ **Trojan horses**: Pretend to be a utility. Convince users to install on PC.
- ❑ **Spyware**: Collect personal information
- ❑ **Hoax**: Use emotion to propagate, e.g., child's last wish.
- ❑ **Trap Door**: Undocumented entry point for debugging purposes
- ❑ **Logic Bomb**: Instructions that trigger on some event in the future
- ❑ **Zombie**: Malicious instructions that can be triggered remotely. The attacks seem to come from other victims.

# Types of Attacks

- ❑ **Denial of Service (DoS):** Flooding with traffic/requests
- ❑ **Buffer Overflows:** Error in system programs. Allows hacker to insert his code in to a program.
- ❑ **Malware**
- ❑ **Brute Force:** Try all passwords.
- ❑ **Port Scanning:**
  - ⇒ Disable unnecessary services and close ports
- ❑ **Network Mapping**

# Buffer Overflows

- ❑ Return address are saved on the top of stack.
- ❑ Parameters are then saved on the stack.
- ❑ Writing data on stack causes stack overflow.
- ❑ Return the program control to a code segment written by the hacker.

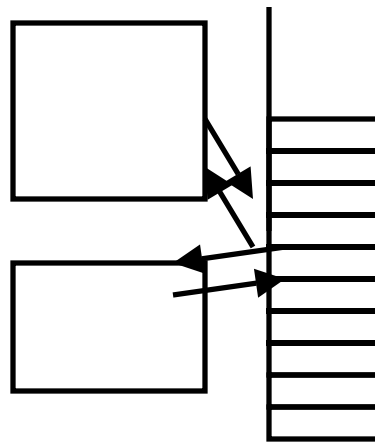



# Distributed DoS Attacks

- ❑ **Tribe Flood Network** (TFN) clients are installed on compromised hosts.
- ❑ All clients start a simultaneous DoS attack on a victim on a trigger from the attacker.
- ❑ **Trinoo** attack works similarly. Use UDP packets. Trinoo client report to Trinoo master when the system comes up.
- ❑ **Stacheldraht** uses handlers on compromised hosts to receive encrypted commands from the attacker.

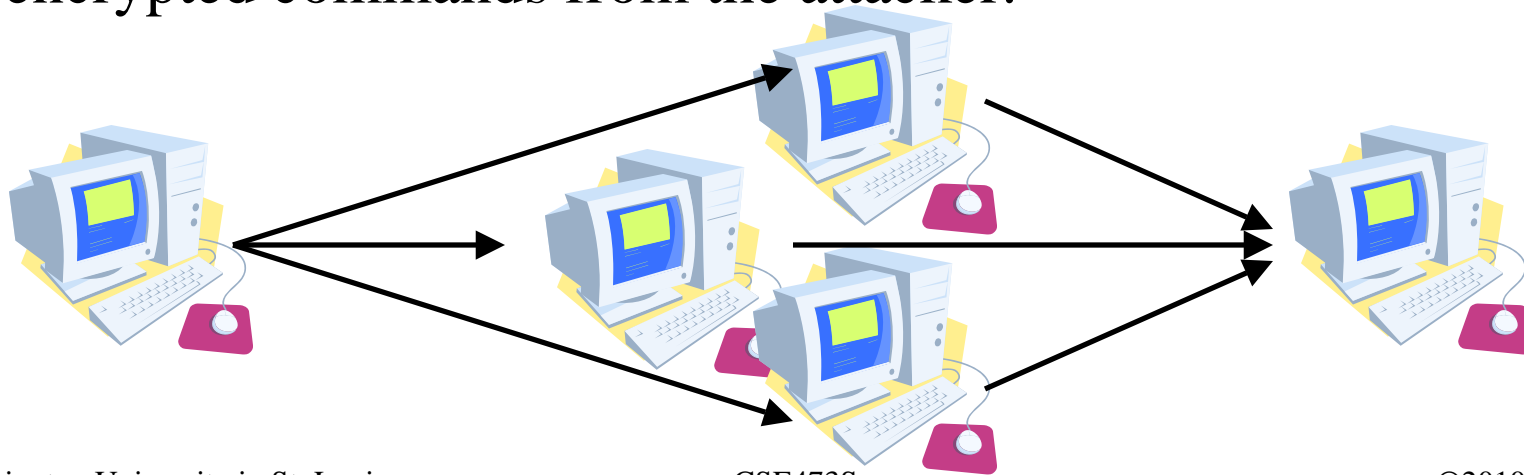

# History of Internet

- ❑ 1961: Kleinrock developed queueing theory. Showed effectiveness of packet-switching
- ❑ 1964: Baran's report on packet-switching in military nets
- ❑ 1967: ARPAnet conceived by Advanced Research Projects Agency
- ❑ 1969: First ARPAnet node operational  
First Request for Comment (RFC)

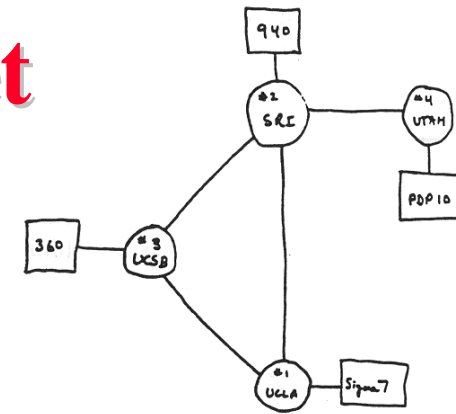

THE ARPA NETWORK

[www.ietf.org](http://www.ietf.org)

# Internet Generations

## Internet 1.0 (1969 – 1989)

- Single ownership  $\Rightarrow$  Trust
- complete knowledge
- Algorithmic optimality  $\Rightarrow$  RIP

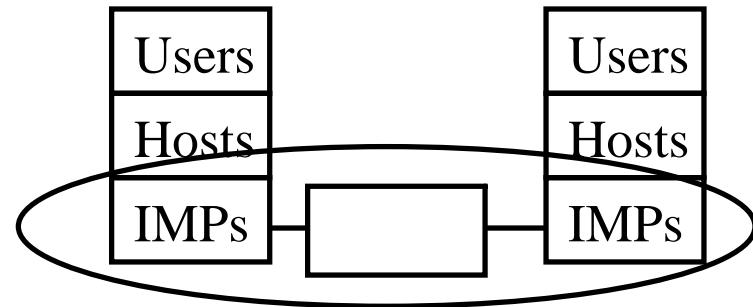

## Internet 2.0 (1989–2009) Commerce

- Multiple ownership of infrastructure  $\Rightarrow$  Distrust, **Security**
- No knowledge of internal topology and resources
- Policy based** routing  $\Rightarrow$  BGP

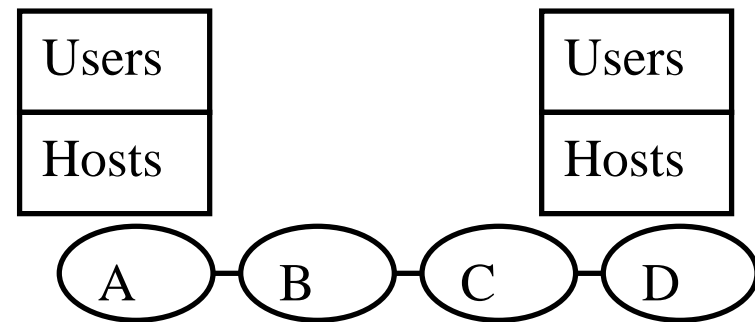

## Internet 3.0 (2009–2029) Commerce

- Users, Content, Host ownership
- Requirements, Service Negotiation
- Mobility of users and distributed data

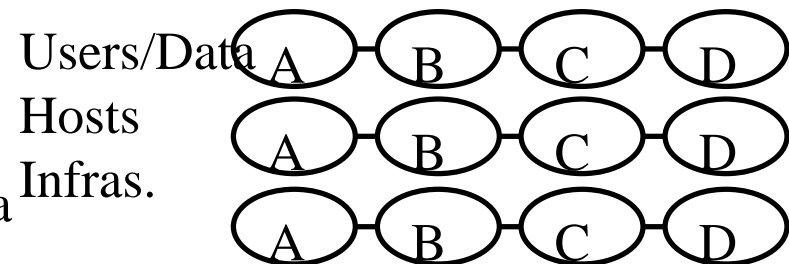

# History of Internet (Cont)

- ❑ Early 1990s: HTML, HTTP: Berners-Lee
- ❑ 1994: Mosaic, later Netscape
- ❑ 2007:
  - ❑ ~500 million hosts
  - ❑ Voice, Video over IP
  - ❑ P2P applications: BitTorrent (file sharing) Skype (VoIP), PPLive (video)
  - ❑ Video applications: YouTube, gaming
  - ❑ Wireless, Mobility

# Key Concepts

- ❑ Internet Protocol (IP): Protocol
- ❑ Address: All systems have an IP address, for example, 125.36.47.23
- ❑ Name: All systems have a human readable name, e.g., scorpio.cec.wustl.edu, ibm.com.
- ❑ Technically called DNS (domain name systems) name. Details will be introduced later.
- ❑ IETF: Internet Engineering Task Force. Make standards for Internet. IETF.org
- ❑ RFC: Request for comments. Documents that describe Internet protocols.

# Homework 1C

1. Find the IP address of your computer
2. Find the IP address of [www.google.com](http://www.google.com) (different from google.com)
3. Measure delay from your computer to [www.google.com](http://www.google.com)

For all cases submit the screen snapshot showing the command used and the output. (Use Alt-Print-screen to capture a window to clipboard and then paste to word)

# Summary

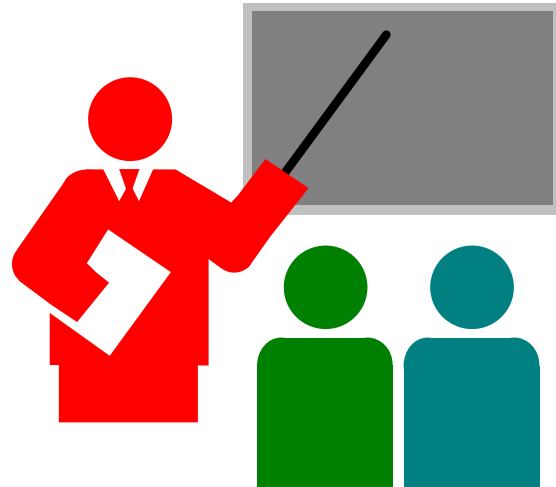

1. Most common medium is UTP, wireless, fiber
2. Internet is a network of networks
3. Enterprise, access, and core networks
4. Performance Measures: Delay, Throughput, Loss Rate
5. Protocol Layers: ISO and TCP/IP reference models

**Thank You!**





# Solution to Homework 1A

- Which networking media will you use for the following applications and why?
  1. Very large file transfer at home: CAT-6 UTP for gigabit Ethernet
  2. High-speed multiple channel video transmission at office: Fiber or Coax
  3. News reading while traveling in a car: wireless

# Solution to Homework 1B

P5: Consider two hosts, A and B, connected by a single link of rate  $R$  bps. Suppose that the two hosts are separated by  $m$  meters, and suppose the propagation speed along the link is  $s$  meters/sec. Host A is to send a packet of size  $L$  bits to Host B.

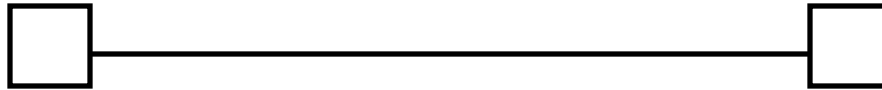

A. Express the propagation delay,  $d_{prop}$  in terms of  $m$  and  $s$

$$d_{prop} = m/s$$

B. Determine the transmission time of the packet  $d_{trans}$  in terms of  $L$  and  $R$ .

$$d_{trans} = L/R$$

C. Ignoring processing queuing delays, obtain an expression for the end-to-end delay

$$\text{Delay} = d_{trans} + d_{prop} = m/s + L/R$$

D. Suppose Host A begins to transmit the packet at time  $t=0$ . At time  $t=d_{trans}$  where is the last bit of the packet?

*Just entering the wire*

## Solution to Homework 1B (Cont)

E. Suppose  $d_{prop}$  is greater than  $d_{trans}$ . At time  $t=d_{trans}$ , where is the first bit of the packet?

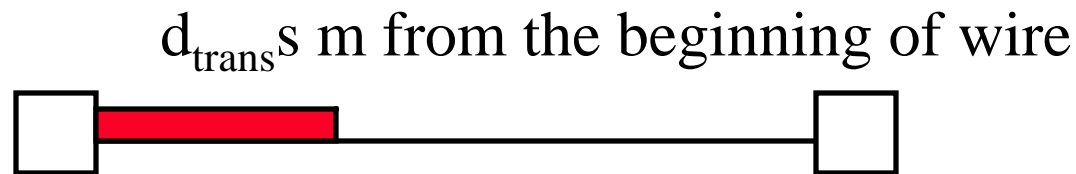

F. Suppose  $d_{prop}$  is less than  $d_{trans}$ , at time  $t=d_{trans}$ , where is the first bit of the packet?

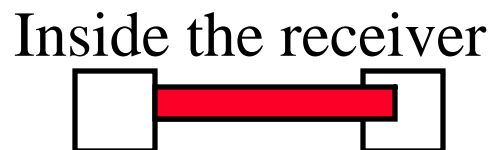

G. Suppose  $s=2.5 \times 10^8$ ,  $L=120$  bits, and  $R=56$  kbps,. Find the distance  $m$  so that  $d_{prop}$  equals  $d_{trans}$ .

$$240/56000 = m/2.5 \times 10^8 \Rightarrow m = 535.5 \text{ km}$$

# Solution to Homework 1C

- ❑ Find the IP address of your computer
  - ❑ Ipconfig
  - ❑ 192.168.0.108
- ❑ Find the IP address of [www.google.com](http://www.google.com)
  - ❑ Ping [www.google.com](http://www.google.com)
  - ❑ 74.125.95.105
- ❑ Measure delay from your computer to [www.google.com](http://www.google.com)

For all cases show the command used and the output.

# Solution to Homework 1C (Cont)

```
D:\exp>tracert www.google.com
```

```
Tracing route to www.l.google.com [74.125.95.105]
```

```
over a maximum of 30 hops:
```

```
 1  <1 ms  <1 ms  <1 ms  192.168.0.1
 2   9 ms   9 ms   9 ms  bras4-10.stlsmo.sbcglobal.net [151.164.182.113]
 3   8 ms   7 ms   7 ms  dist2-vlan50.stlsmo.sbcglobal.net [151.164.14.131]
 4   7 ms   7 ms   7 ms  151.164.93.224
 5  15 ms  15 ms  15 ms  151.164.241.189
 6  21 ms  21 ms  22 ms  72.14.197.85
 7  21 ms  22 ms  21 ms  209.85.254.120
 8  32 ms  26 ms  42 ms  209.85.241.22
 9  32 ms  26 ms  26 ms  209.85.241.35
10  28 ms  34 ms  37 ms  72.14.239.193
11  32 ms  32 ms  33 ms  iw-in-f105.google.com [74.125.95.105]
```

```
Trace complete.
```

# Power-Line Network

