

Computer Networks and the Internet

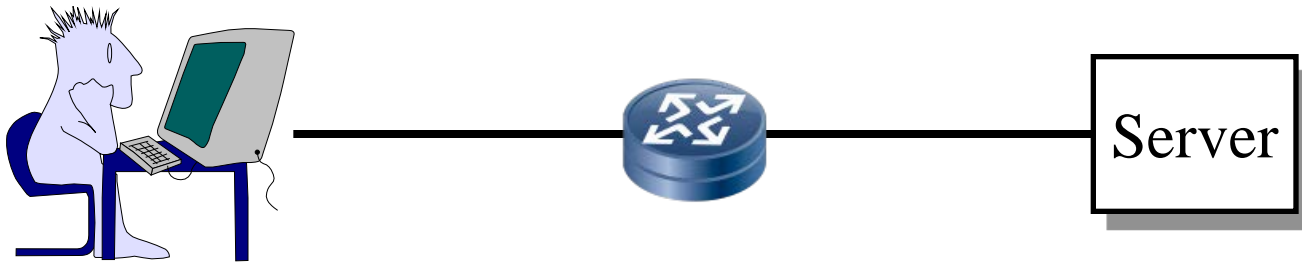

Raj Jain

Washington University in Saint Louis

Saint Louis, MO 63130

Jain@wustl.edu

Audio/Video recordings of this lecture are available on-line at:

<http://www.cse.wustl.edu/~jain/cse473-16/>

1. What is Internet?
2. Network Edge: Access Networks and Media
3. Network Core: Packet vs. Circuit Switching
4. Delay, Loss, and Throughput
5. Protocol Layers
6. Network Security
7. History of Internet



1. What is Internet?
2. Switching: Circuit vs. Packet
3. Edge vs. Core
4. Network Performance Measures: Delay, Loss, Throughput
5. Protocol Layers
6. Network Security
7. History

Note: This class lecture is based on Chapter 1 of the textbook (Kurose and Ross) and the slides provided by the authors.

What is a Network?

- ❑ **Network:** Enables data transfer among nodes
 - ❑ Generally heterogeneous nodes
 - ❑ More than 2 nodes
 - ❑ E.g., Your home or office network

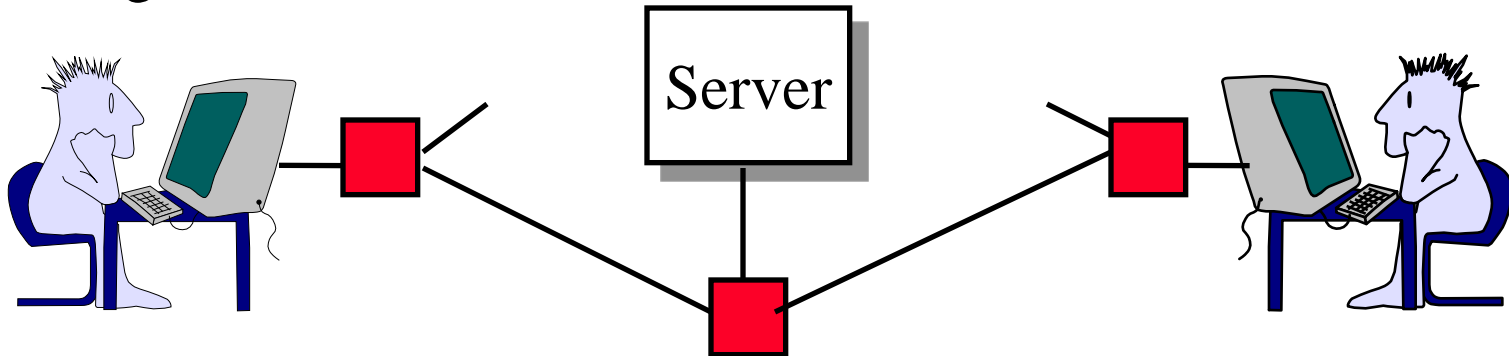

- ❑ **Communication:** Two nodes.
 - ❑ Link level electrical issues.



Key Concepts



- ❑ **End Systems:** Systems that are sinks or sources of data, e.g., Desktops, Laptops, Servers, Printers, Cell Phones, etc.
- ❑ **Intermediate Systems:** Systems that forward/switch data from one link to another, e.g., routers, switches
- ❑ **Hosts:** End Systems
- ❑ **Gateways:** Routers
- ❑ **Servers:** End Systems that provide service, e.g., print server, storage server, Mail server, etc.
- ❑ **Clients:** End systems that request service
- ❑ **Links:** Connect the systems.
Characterized by transmission rate, propagation delay

What is Internet?

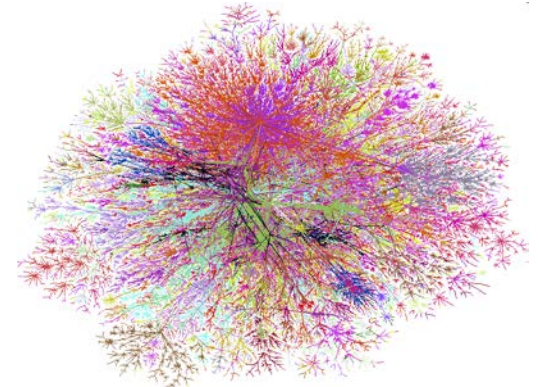
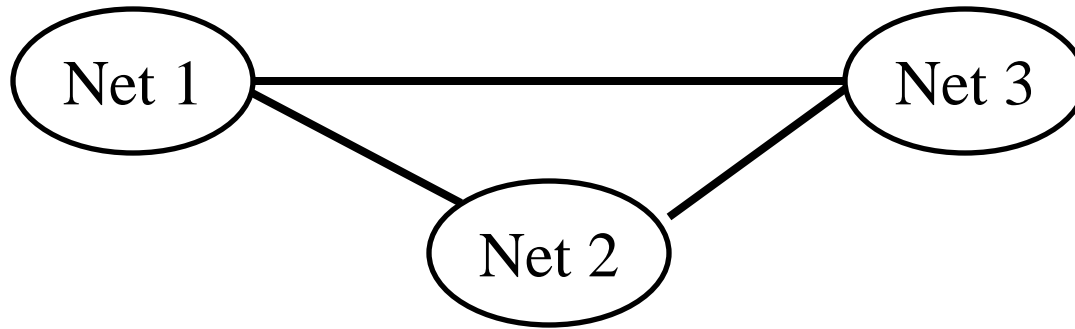

- ❑ Internet = Inter-Network = Network connecting networks
- ❑ Approximately 1.05B hosts on Internet in 2016.
- ❑ ISP: **Internet Service Provider**.
 - ❑ Provide access to Internet.
 - ❑ Telecommunications (Telephone) Companies, AT&T, Verizon, Comcast, ...
 - ❑ Coffee Shops (Wi-Fi)

Types of Networks

□ Point to point vs. Broadcast

Point-to-Point

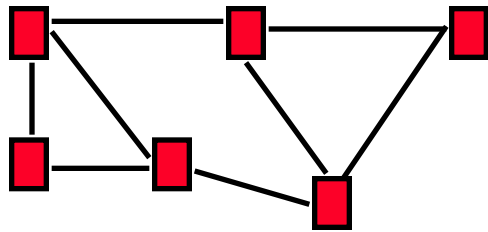

Bus

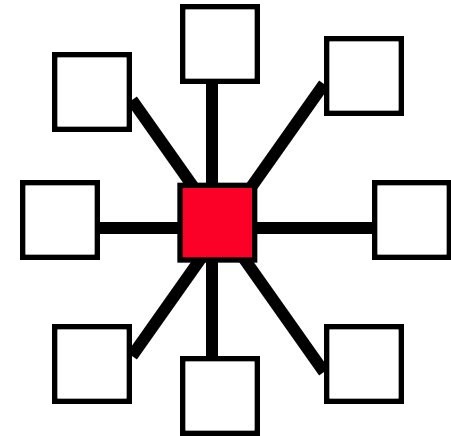
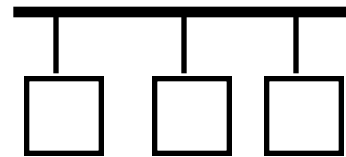

Star

□ Circuit switched vs. packet switched

□ Circuit: A path (circuit) is setup before transmission. All bits follow the same path, e.g., Phone

□ Packet: Packets of bits are forwarded individually

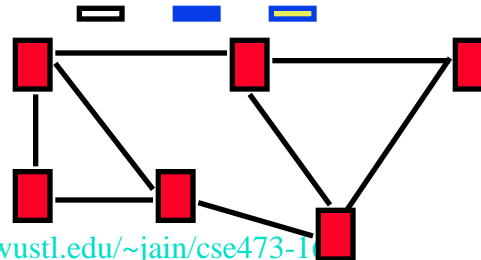
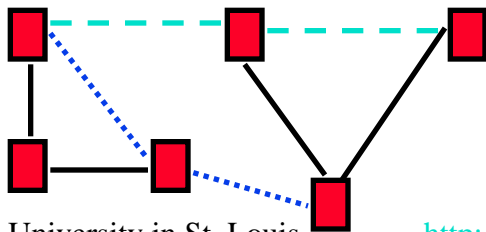



Multiplexing

- How multiple users can share a link?
- **Time Division Multiplexing (TDM)**

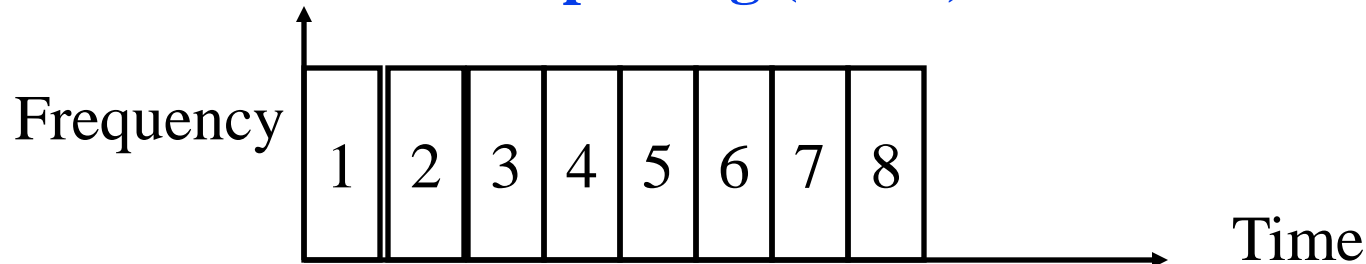

- **Frequency Division Multiplexing (FDM)**

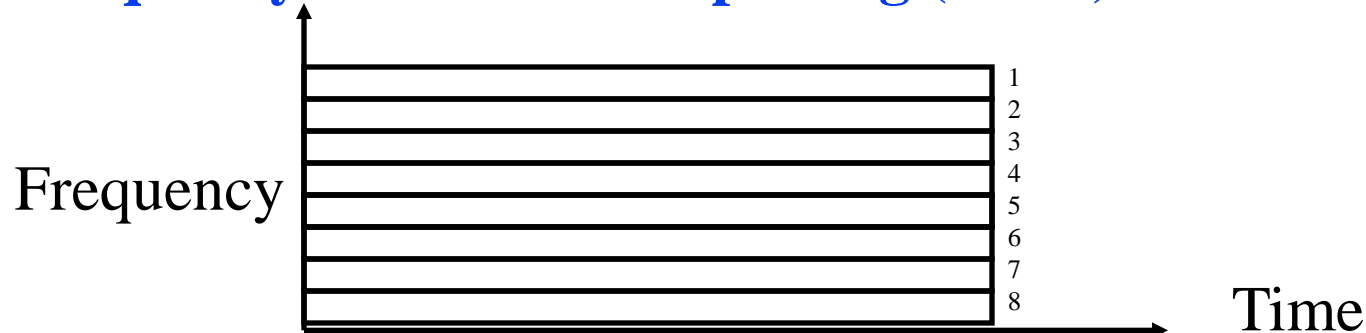

- Other multiplexing methods will be covered as needed.

Types of Networks (Cont)

- ❑ **Local Area Networks (LAN):** 0-2 km, Single Ownership
- Metropolitan Area Networks (MAN)** 2-50 km,
- Wide Area Networks (WAN)** 50+ km
 - ❑ Originally LAN/MAN/WAN technologies were different
 - ❑ Now they are all same
- ❑ **Telecom Networks:**
 - ❑ **Access:** Between subscriber and the service provider
 - ❑ **Metro:** Covering a city
 - ❑ **Core:** Between cities

Structure of the Internet

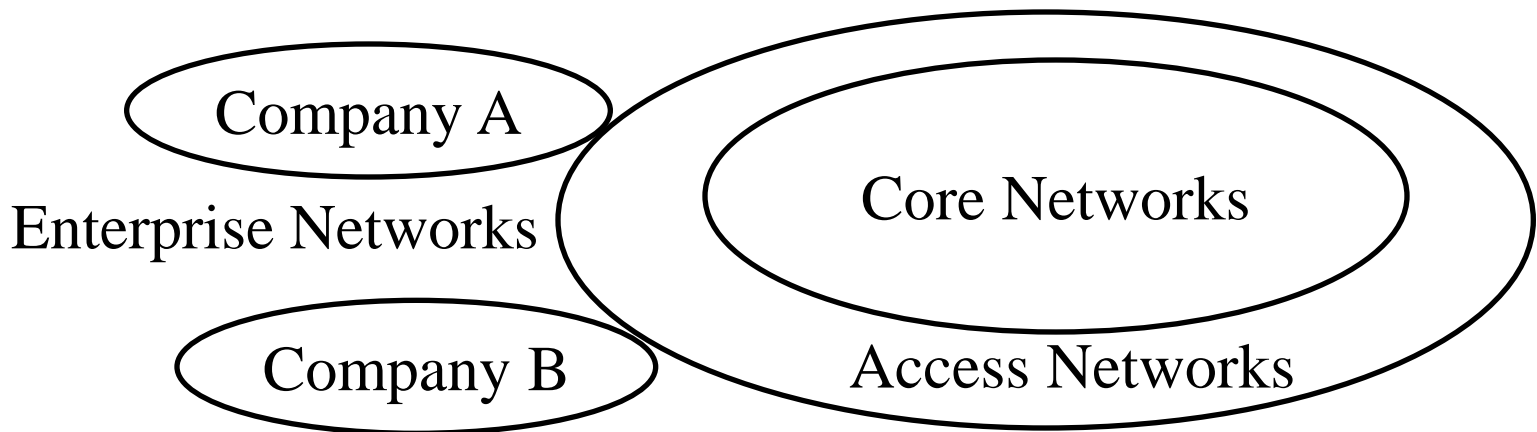

- ❑ Enterprise/Home Networks: Stub Networks.
Privately owned \Rightarrow Not owned by ISP
e.g., WUSTL network: Ethernet and WiFi
- ❑ Access Network: Enterprise/Users to ISP (in the city)
WiFi, 3G/4G, DSL
- ❑ Core Network: ISP's network (between city): Optical Fiber

Types of ISPs

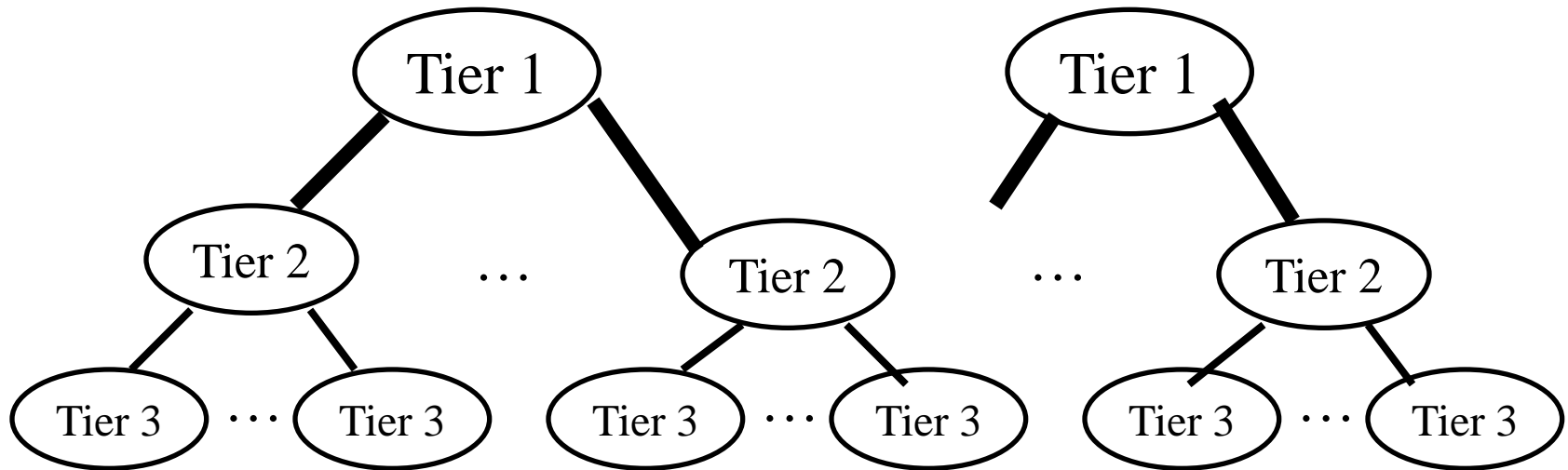

- ❑ Tier 1: Global or National, e.g., AT&T, Verizon, ...
- ❑ Tier 2: Regional
- ❑ Tier 3: Local

Transmission Media

❑ Guided:

- ❑ Twisted Pair
- ❑ Coaxial cable
- ❑ Optical fiber

❑ Unguided:

- ❑ Microwave
- ❑ Satellite
- ❑ Wireless

Twisted Pair (TP)

- Separately insulated
- Twisted together
- Often "bundled" into cables
- Usually installed in building during construction



(a) Twisted pair

- ❑ Twists decrease the cross-talk
- ❑ Neighboring pairs have different twist length
- ❑ Most of telephone and network wiring in homes and offices is TP.

Shielded and Unshielded TP

❑ Shielded Twisted Pair (STP)

- ❑ Metal braid or sheathing that reduces interference
- ❑ More expensive
- ❑ Harder to handle (thick, heavy)
- ❑ Used in token rings



❑ Unshielded Twisted Pair (UTP)

- ❑ Ordinary telephone wire
- ❑ Cheap, Flexible
 - ⇒ Easiest to install
- ❑ No shielding
 - ⇒ Suffers from external interference
- ❑ Used in Telephone and Ethernet

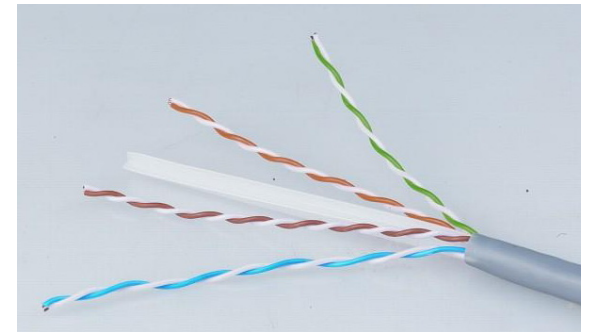

UTP Categories

❑ Cat 3

- ❑ Up to 16MHz
- ❑ Voice grade found in most offices
- ❑ Twist length of 7.5 cm to 10 cm

❑ Cat 4

- ❑ Up to 20 MHz. Not used much in practice.

❑ Cat 5

- ❑ Up to 100MHz
- ❑ Used in 10 Mbps and 100 Mbps Ethernet
- ❑ Twist length 0.6 cm to 0.85 cm

❑ Cat 5E (Enhanced), Cat 6, Cat 7, ...

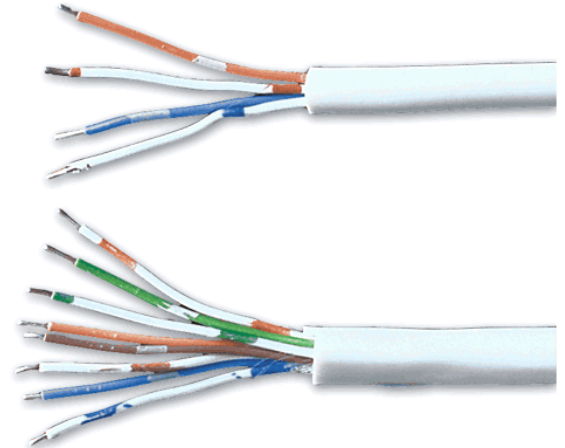

Optical Fiber

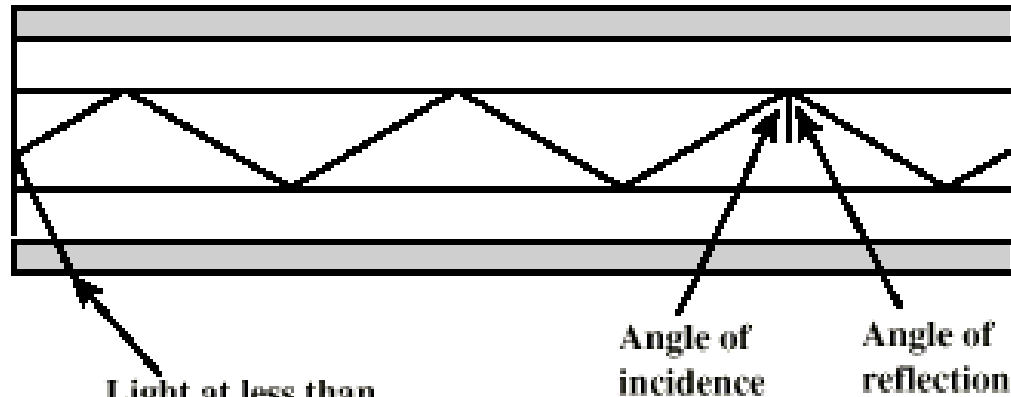
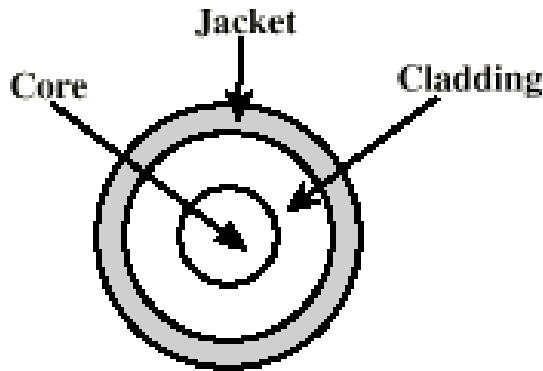

- Glass or plastic core
- Laser or light emitting diode
- Specially designed jacket
- Small size and weight

Light at less than critical angle is absorbed in jacket

- ❑ A cylindrical mirror is formed by the cladding
- ❑ The light wave propagate by continuous reflection in the fiber
- ❑ Not affected by external interference \Rightarrow low bit error rate
- ❑ Fiber is used in all long-haul or high-speed communication
- ❑ Infrared light is used in communication

Optical Communication...History

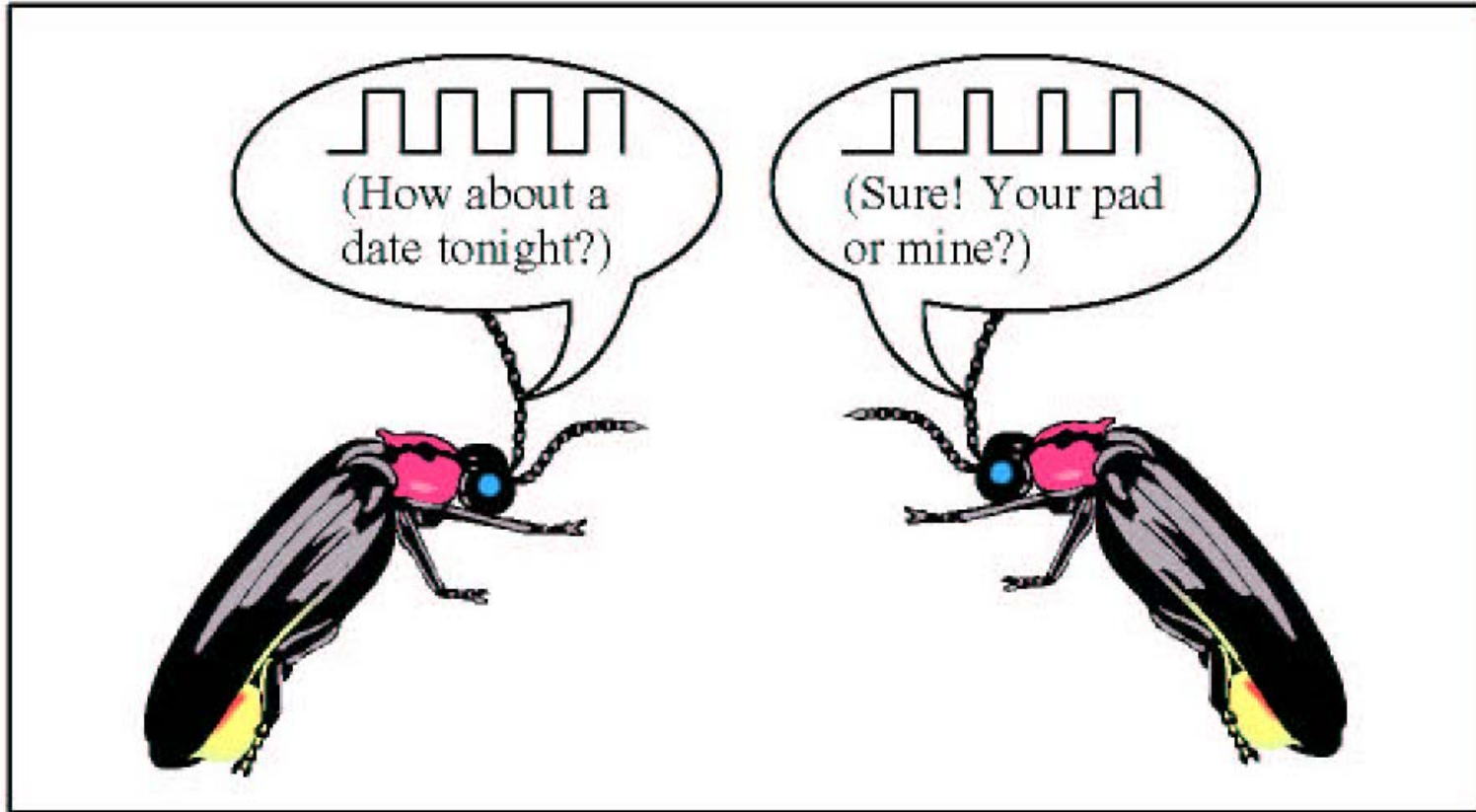

Fireflies use pulse-width modulation.

Electromagnetic Spectrum

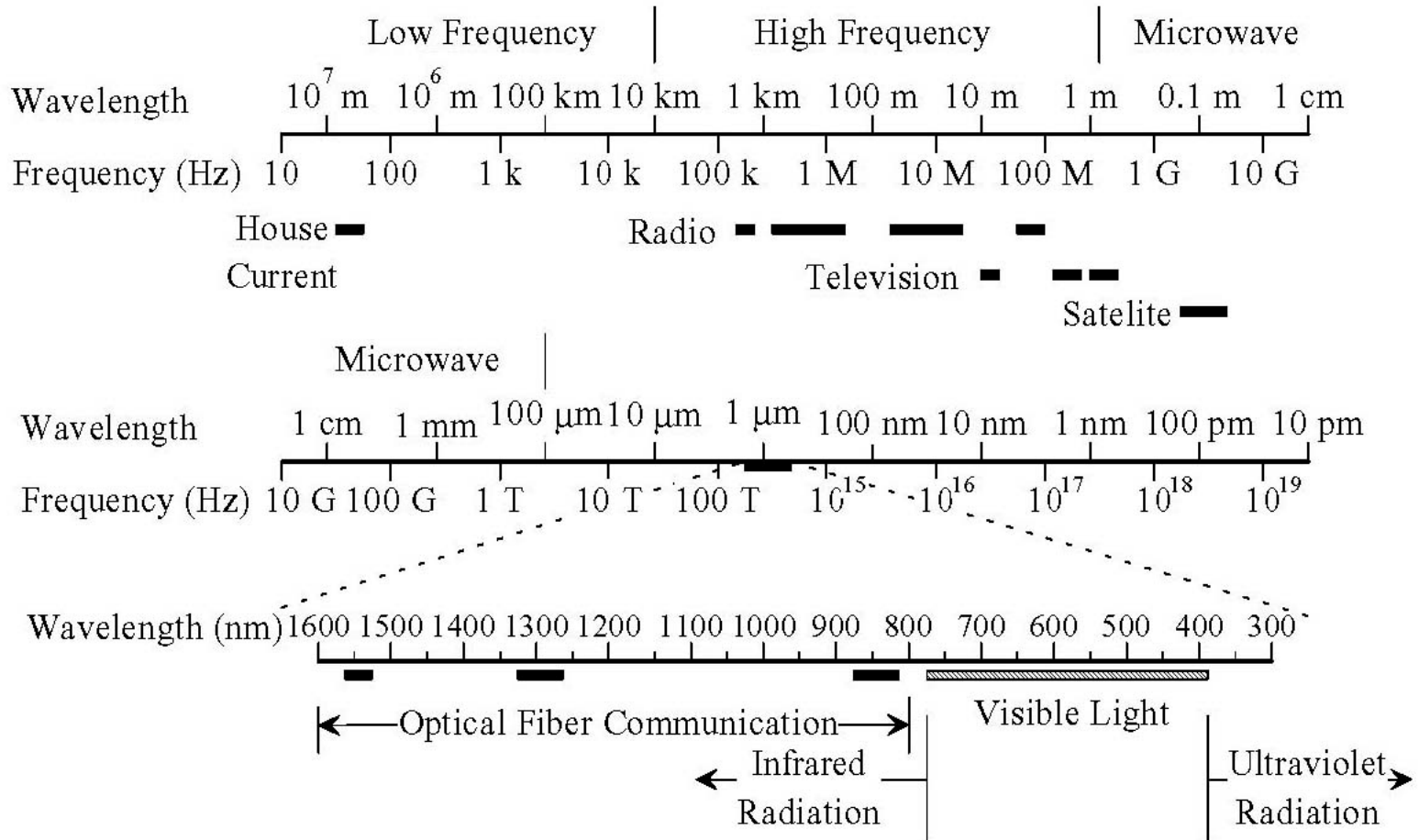

- Infrared light is used for optical communication

Homework 1A

- ❑ Which networking media will you use for the following applications and why?
 1. Very large file transfer at home
 2. High-speed multiple channel video transmission at office
 3. News reading while traveling in a car

Note: Do not write the name of the protocol. Write the name of the media and justify.

Network Edge: Enterprise Networks

1. Ethernet
2. Wi-Fi

Ethernet

- ❑ Uses UTP (Unshielded Twisted Pair)
- ❑ 10 Mbps, 100 Mbps, 1 Gbps, 10 Gbps
- ❑ Originally bus, now point-to-point (Star) topology

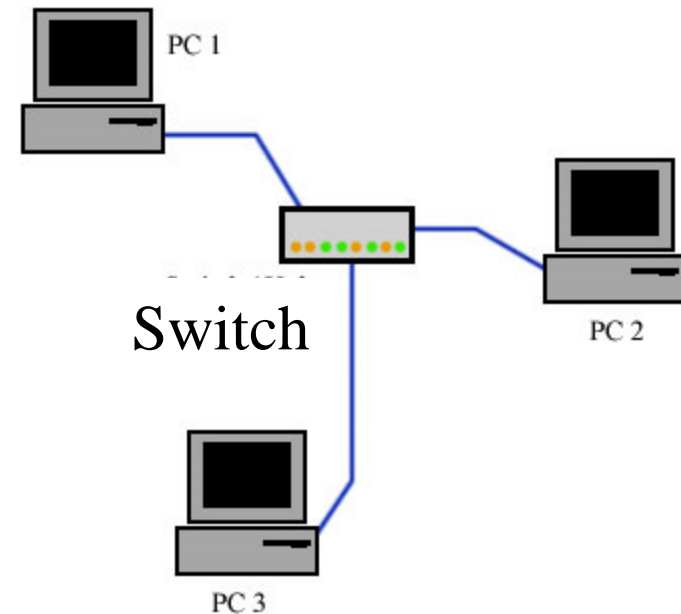
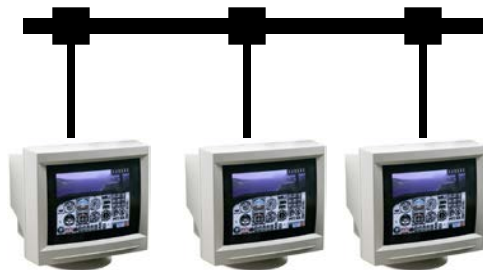

Wi-Fi

- ❑ IEEE 802.11
- ❑ Uses 2.4 GHz and 5.8 GHz



Access Networks

1. DSL
2. Cable
3. Fiber-To-The-Home
4. Wi-Fi
5. LTE

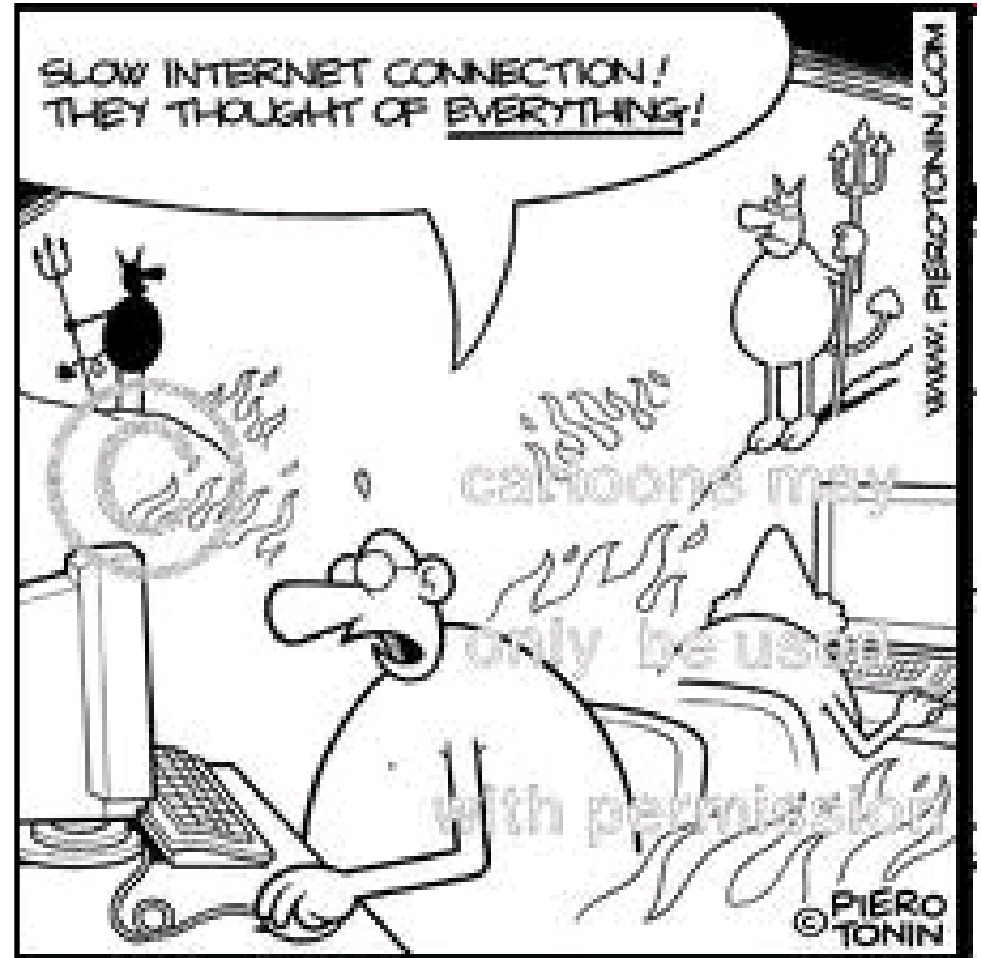

DSL

- ❑ **Digital Subscriber Line (DSL)**
- ❑ Can transmit very high data rates on phone wire using special equipment at the phone company allowing higher frequency signals

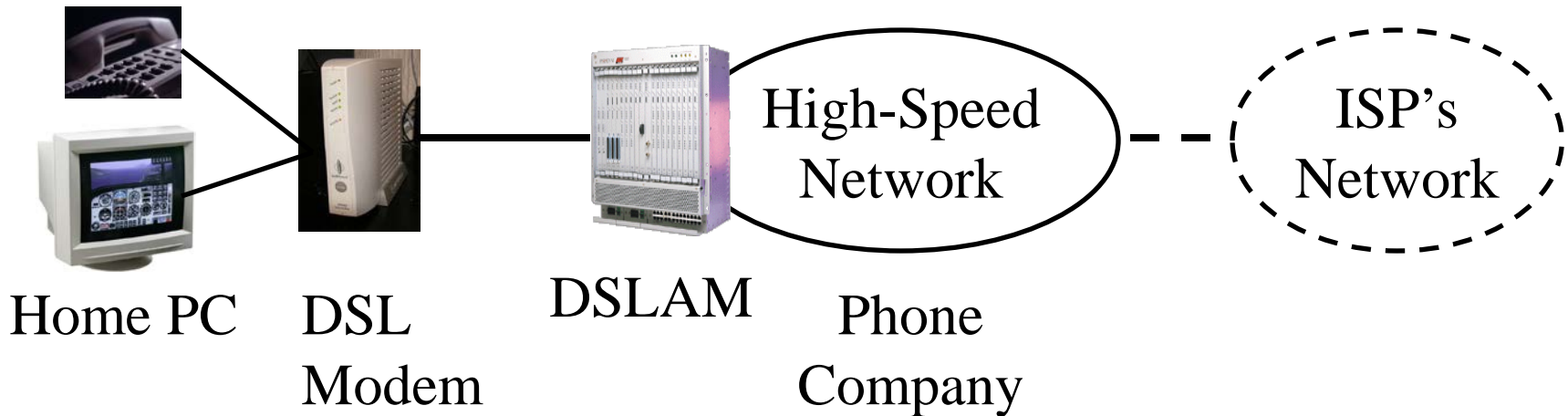

- ❑ DSL Access Multiplexer (DSLAM)
- ❑ 100 kbps - 100 Mbps

Cable



- ❑ Cable companies have a very-high speed medium (for video transmission)
- ❑ Phone wire = 4kHz for voice
Video Cable = 500 MHz for video
One TV Channel = 6 MHz
- ❑ 30 Mbps down/1 Mbps up
- ❑ Fiber in the main line + Coax in tributaries
⇒ Hybrid Fiber Coax (HFC)



Cable Modem

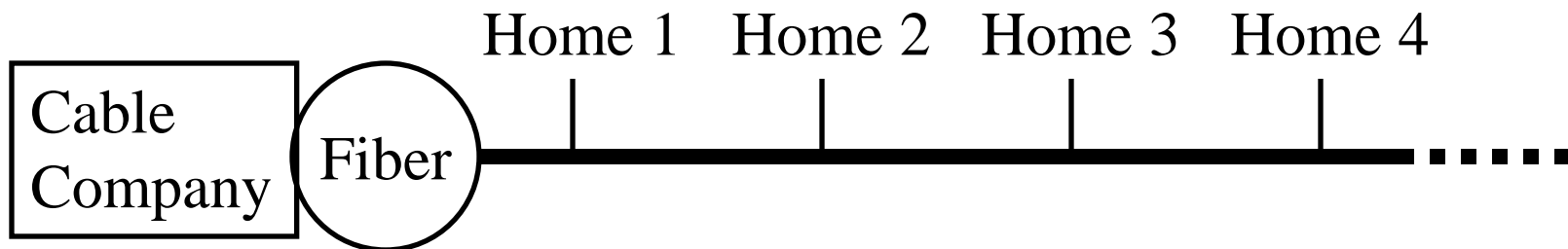

Fiber-To-The-Home (FTTH)

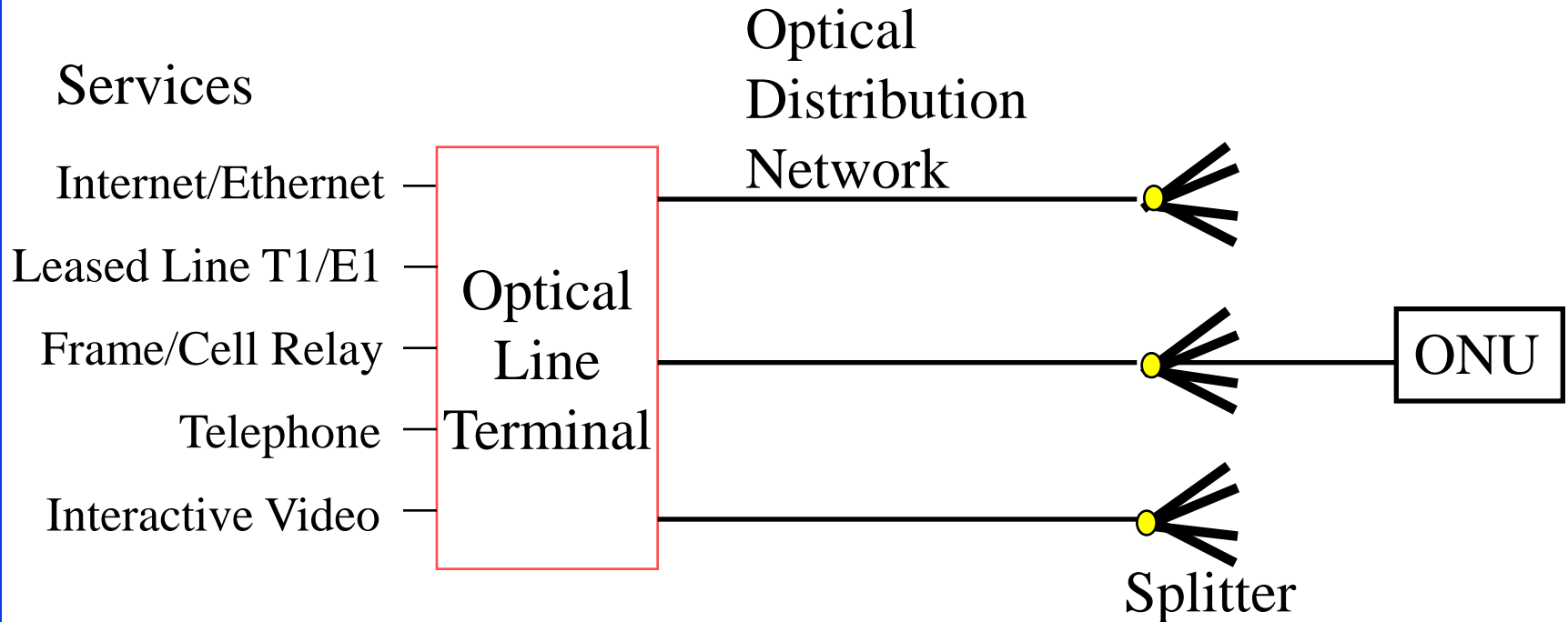

- ❑ 100+ Mbps per home. Multiple services.
- ❑ No electronic components in the distribution system
⇒ Passive ⇒ Reliable
- ❑ Passive Optical Network (PON)

Wireless Access Networks

- ❑ Wi-Fi hot spots
- ❑ Cellular access: 2G/3G/4G (LTE)

Network Performance Measures

- ❑ Delay
- ❑ Throughput
- ❑ Loss Rate

Throughput

- ❑ Measured in Bits/Sec
- ❑ Capacity: Nominal Throughput
- ❑ Throughput: Realistic
- ❑ Bottleneck determines the end-to-end throughput



Net end-to-end capacity = 10 Mbps

Actual throughput will be less due to sharing and overhead.

Loss Rate

- ❑ Queuing \Rightarrow Buffer overflow
- ❑ Bit Error Rate on the link
- ❑ Lost packets are retransmitted by the previous node or the source

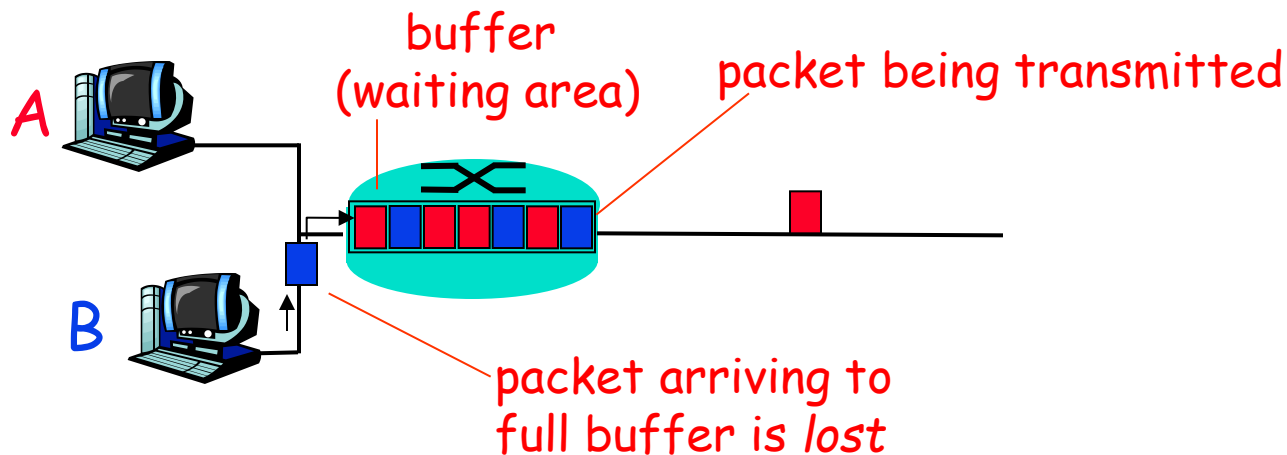

Packet Switching Delay

1. Processing Delay: Check packets, decide where to send, etc.
2. Queuing Delay: Wait behind other packets
3. Transmission Delay: First-bit out to last-bit out on the wire
= Packet Length/bit rate
4. Propagation Delay: Time for a bit to travel from in to out
= Distance/speed of signal

Light speed = 3×10^8 m/s in vacuum, 2×10^8 m/s in fiber

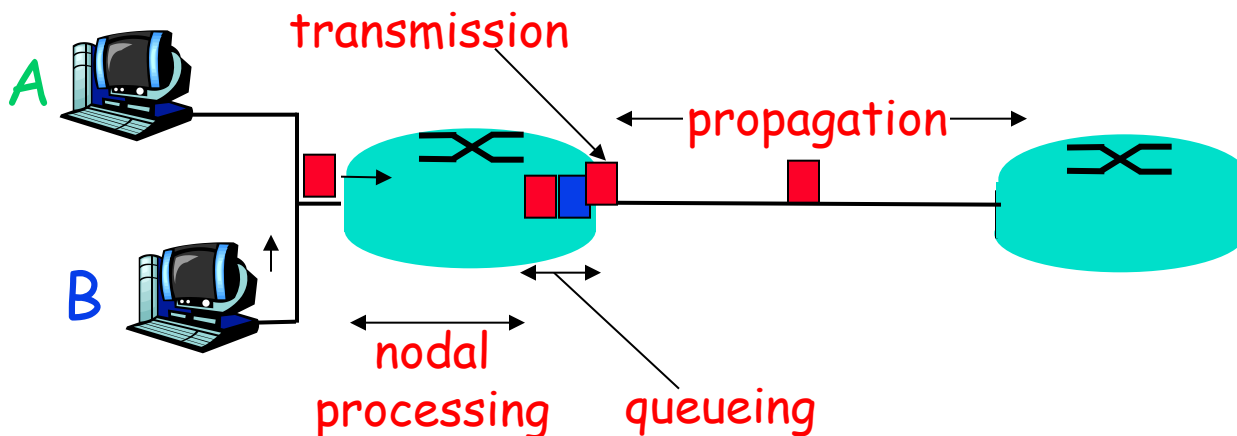

Packet Switching Delay: Example

- ❑ 1500 Byte packets on 10 Mbps Ethernet, 1km segment
- ❑ Transmission Delay = $1500 \times 8 / 10 \times 10^6 = 1200 \mu\text{s} = 1.2\text{ms}$
- ❑ Propagation delay = $1000 \text{ m} / 2 \times 10^8 = 5 \mu\text{s}$

Delay Example (CBR Circuits)

- ❑ How long would it take to send a file of 640,000 bits from host A to host B over a circuit-switched network?
 - ❑ All links are 1.536 Mbps
 - ❑ Each link is shared by 24 users
 - ❑ 500 ms to establish end-to-end circuit
- ❑ Per User Rate = $1536/24 = 64$ kbps
- ❑ Time to transfer = $640\text{kb}/64\text{kb} = 10$ s
- ❑ Total time = $.5$ s + 10 s = 10.5 s

Homework 1B

- P5: Consider two hosts, A and B, connected by a single link of rate R bps. Suppose that the two hosts are separated by m meters, and suppose the propagation speed along the link is s meters/sec. Host A is to send a packet of size L bits to Host B.
- A. Express the propagation delay, d_{prop} in terms of m and s
 - B. Determine the transmission time of the packet d_{trans} in terms of L and R .
 - C. Ignoring processing queuing delays, obtain an expression for the end-to-end delay
 - D. Suppose Host A begins to transmit the packet at time $t=0$. At time $t=d_{trans}$ where is the last bit of the packet?
 - E. Suppose d_{prop} is greater than d_{trans} . At time $t=d_{trans}$, where is the first bit of the packet?
 - F. Suppose d_{prop} is less than d_{trans} , at time $t=d_{trans}$, where is the first bit of the packet
 - G. Suppose $s=2.5 \times 10^8$ m/s, $L=240$ bits, and $R=56$ kbps,. Find the distance m so that d_{prop} equals d_{trans} .

Protocol Layers

- Problem: Philosophers in different countries speak different languages. The Telex system works only with English.

I believe there is a God!

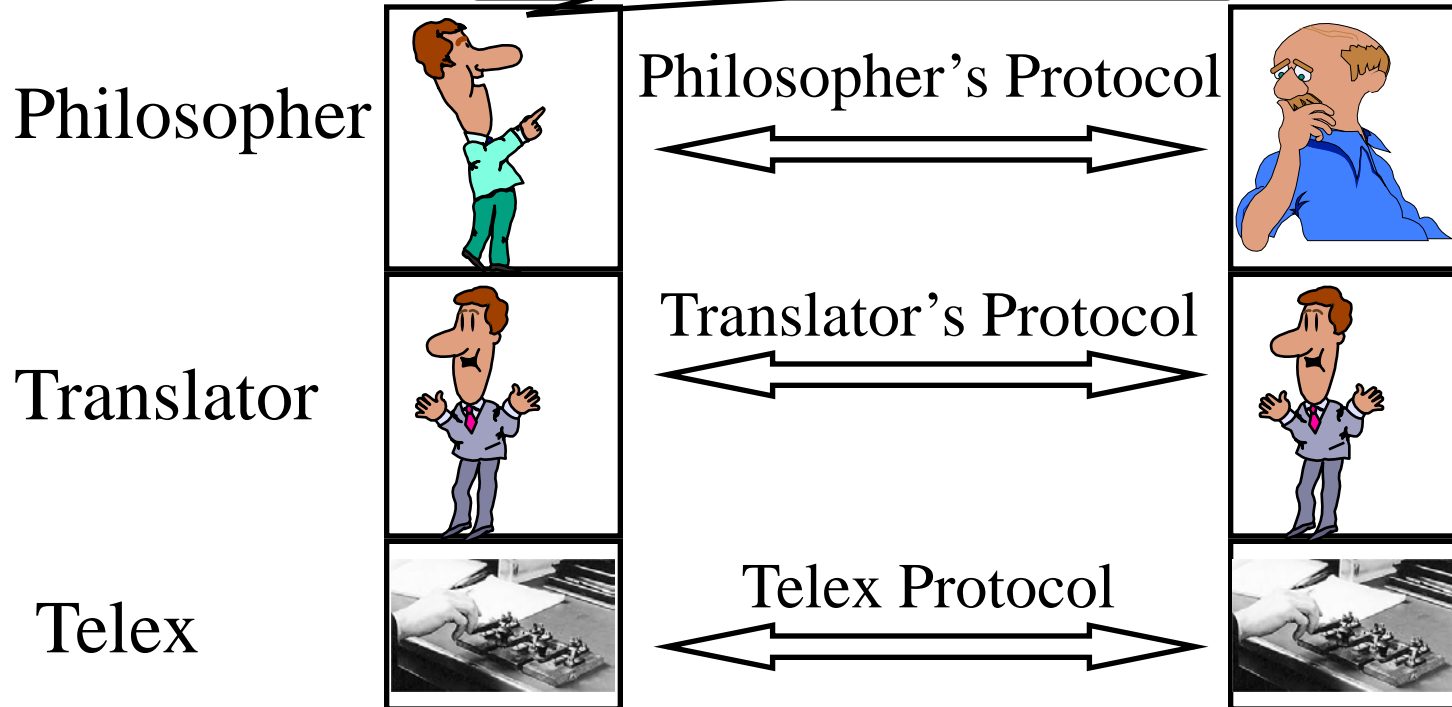

What is a Networking Protocol?

- Network protocols define the format of messages, their meanings, sequence, and actions



ISO/OSI Reference Model

5	Application	File transfer, Email, Remote Login
	Presentation	ASCII Text, Sound
	Session	Establish/manage connection
4	Transport	End-to-end communication: TCP
3	Network	Routing, Addressing: IP
2	Datalink	Two party communication: Ethernet
1	Physical	How to transmit signal: Coding

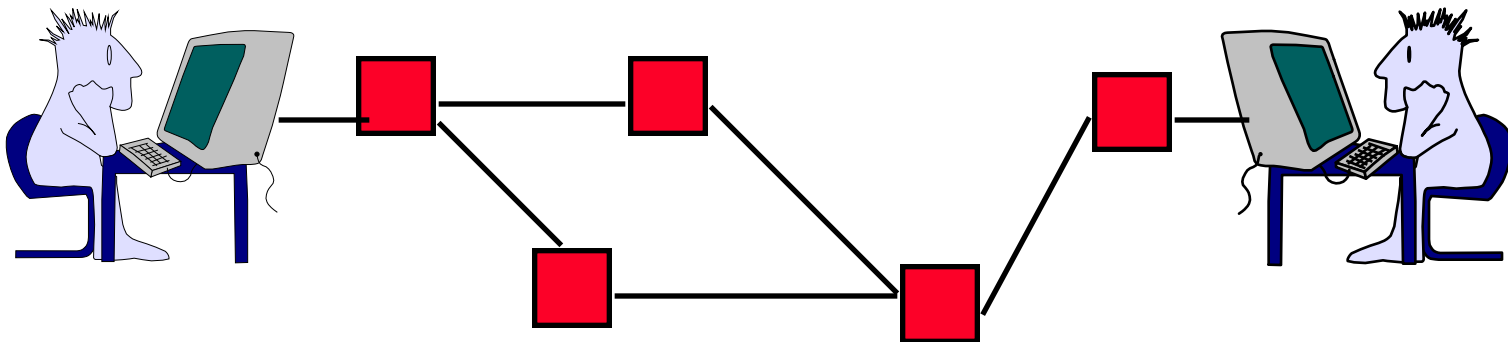

Service and Protocol Data Units

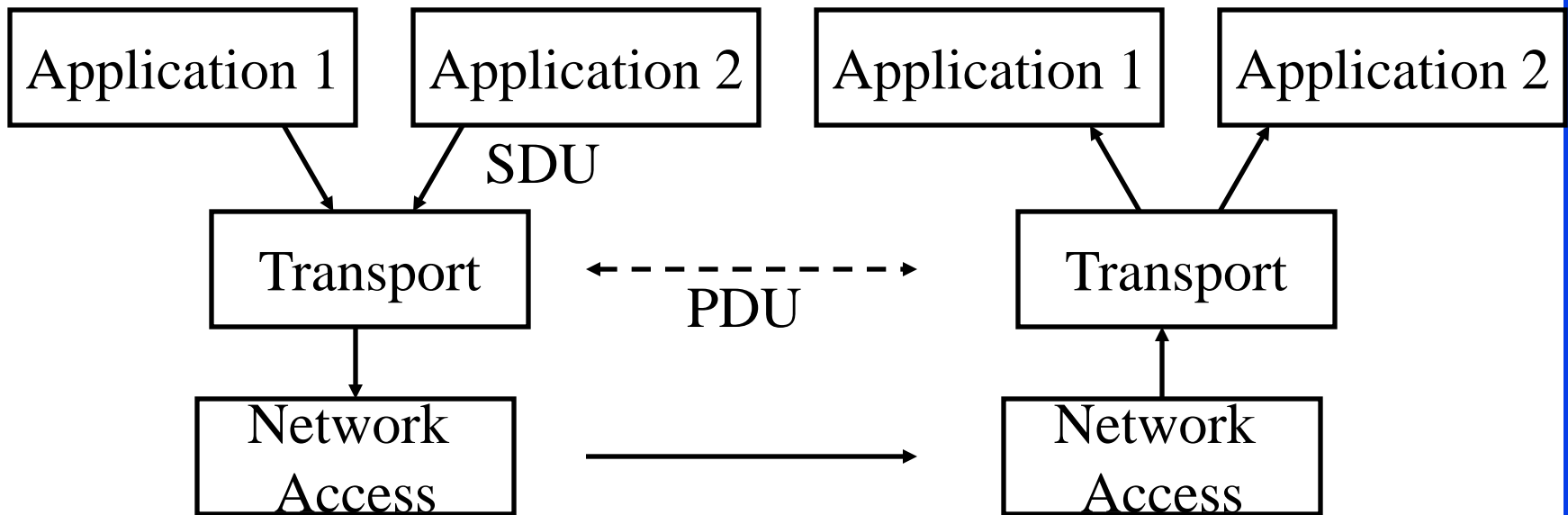

- ❑ Service Access Points (SAPs)
- ❑ Service Data Units (SDUs)
- ❑ Protocol Data Units (PDUs)

Service Data Unit (SDU)

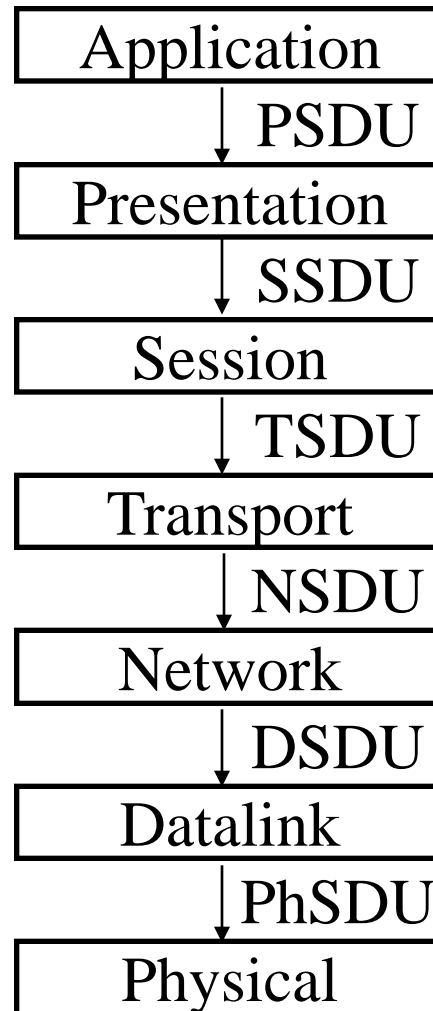

Protocol Data Unit (PDU)

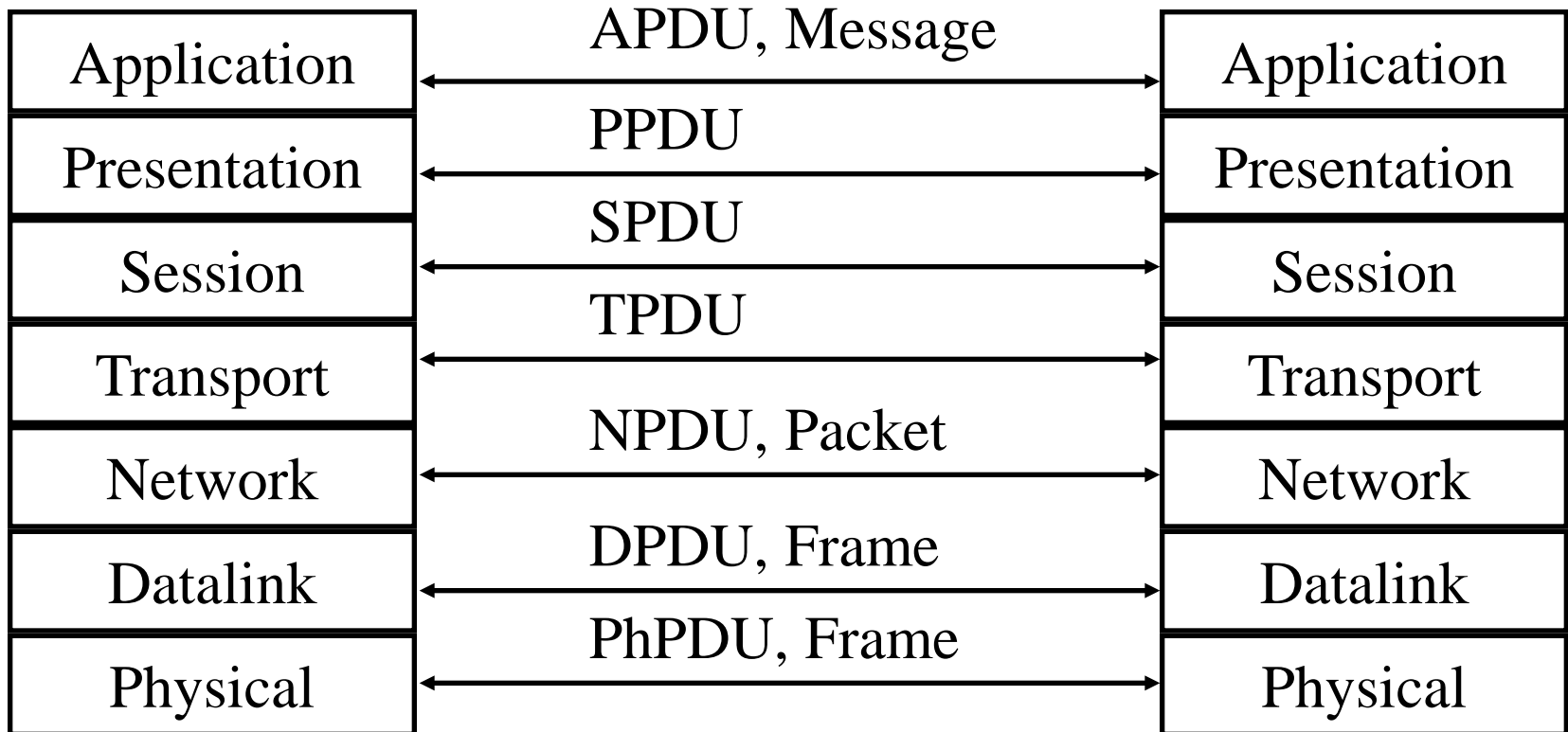

TCP/IP Reference Model

- ❑ TCP = Transport Control Protocol
- ❑ IP = Internet Protocol (Routing)

TCP/IP Ref Model

TCP/IP Protocols

Application
Transport
Internetwork
Host to Network
Physical

FTP	Telnet	HTTP
TCP		UDP
IP		
Ethernet	Point-to-Point	Packet Radio
Coax	Fiber	Wireless

OSI vs TCP/IP

OSI	TCP/IP
Application	Application
Presentation	
Session	
Transport	Transport (host-to-host)
Network	Internet
Data Link	Network Access
Physical	Physical

OSI vs TCP Reference Models

- ❑ OSI introduced concept of services, interface, protocols. These were force-fitted to TCP later
⇒ It is not easy to replace protocols in TCP.
- ❑ In OSI, reference model was done before protocols. In TCP, protocols were done before the model
- ❑ OSI: Standardize first, build later
TCP: Build first, standardize later
- ❑ OSI took too long to standardize. TCP/IP was already in wide use by the time.
- ❑ OSI became too complex.
- ❑ TCP/IP is not general. Ad hoc.

PDU in TCP/IP Architecture

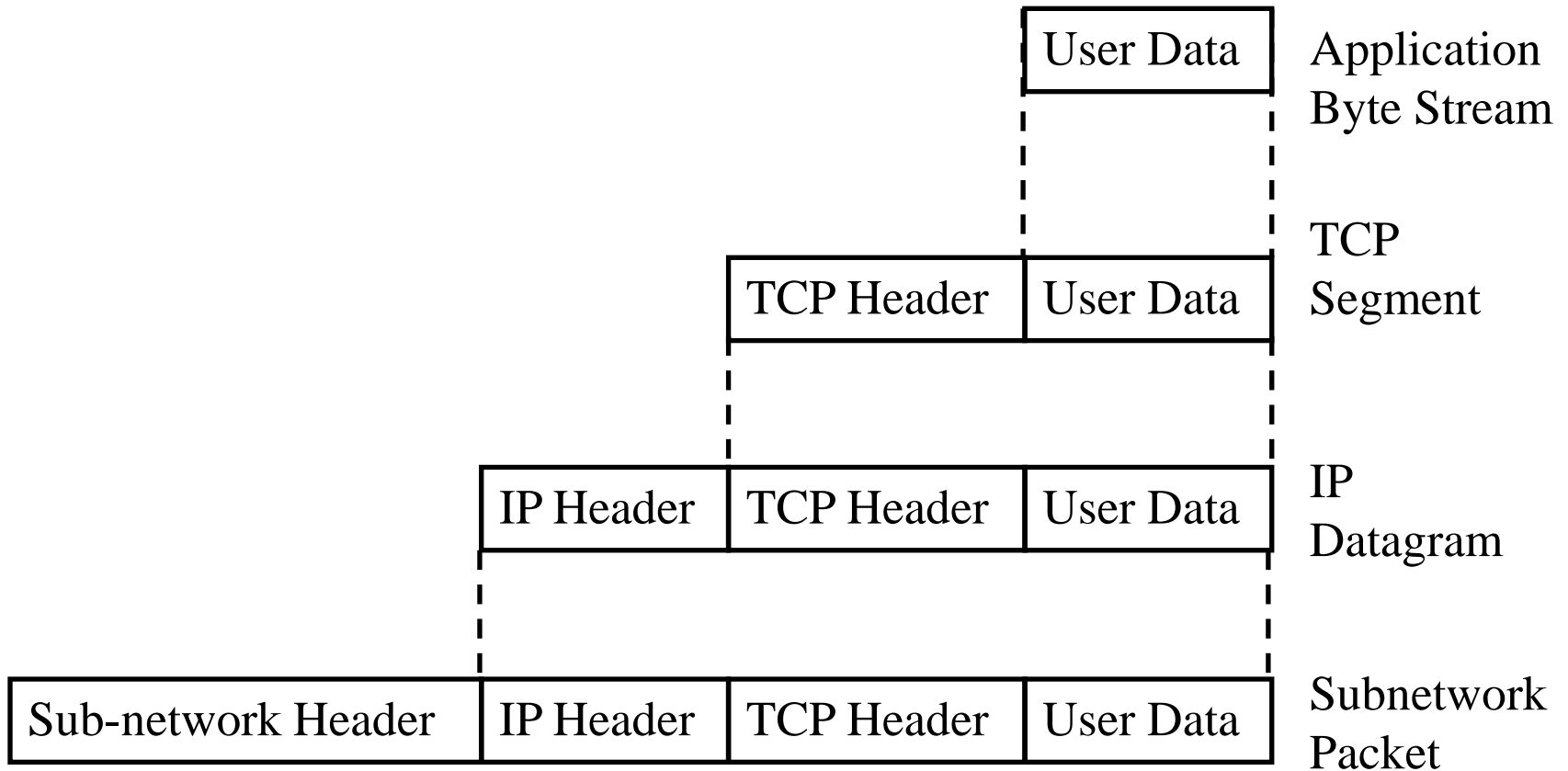

TCP/IP Applications

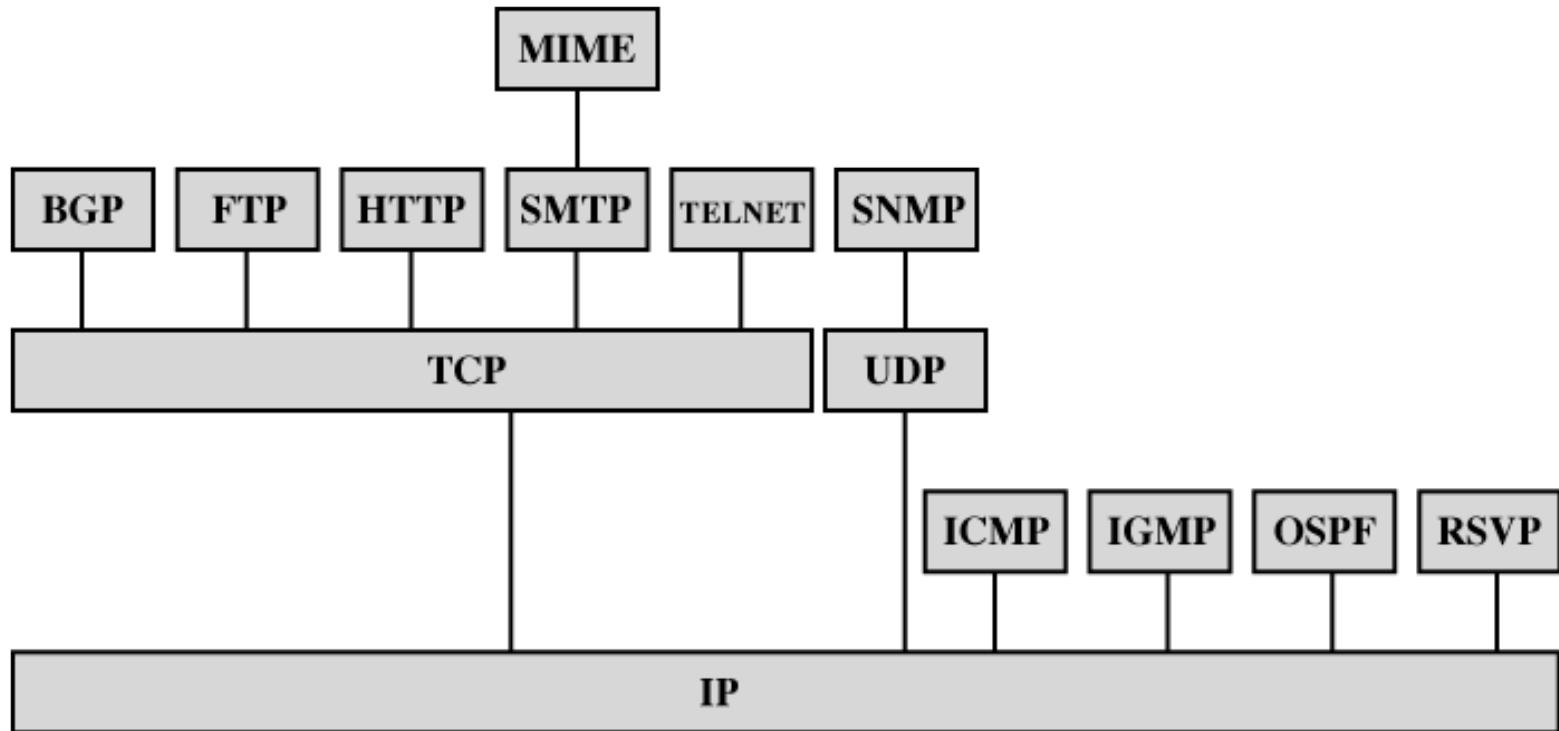

BGP = Border Gateway Protocol

FTP = File Transfer Protocol

HTTP = Hypertext Transfer Protocol

ICMP = Internet Control Message Protocol

IGMP = Internet Group Management Protocol

IP = Internet Protocol

MIME = Multi-Purpose Internet Mail Extension

OSPF = Open Shortest Path First

RSVP = Resource ReSerVation Protocol

SMTP = Simple Mail Transfer Protocol

SNMP = Simple Network Management Protocol

TCP = Transmission Control Protocol

UDP = User Datagram Protocol

Network Security

- ❑ Security Components
- ❑ Types of Malware
- ❑ Types of Attacks
- ❑ Buffer Overflows
- ❑ Distributed DoS Attacks

Security Components

- ❑ **Confidentiality**: Need access control, Cryptography, Existence of data
- ❑ **Integrity**: No change, content, source, prevention mechanisms, detection mechanisms
- ❑ **Availability**: Denial of service attacks,
- ❑ Confidentiality, Integrity and Availability (**CIA**)



Types of Malware

- ❑ **Viruses:** Code that *attaches* itself to programs, disks, or memory to propagate itself.
- ❑ **Worms:** Installs copies of itself on other machines on a network, e.g., by finding user names and passwords
- ❑ **Trojan horses:** Pretend to be a utility. Convince users to install on PC.
- ❑ **Spyware:** Collect personal information

This is not a complete list.

Types of Attacks

- ❑ **Denial of Service (DoS):** Flooding with traffic/requests
- ❑ **Buffer Overflows:** Error in system programs. Allows hacker to insert his code in to a program.
- ❑ **Malware**
- ❑ **Brute Force:** Try all passwords.
- ❑ **Port Scanning:**
 - ⇒ Disable unnecessary services and close ports
- ❑ **Network Mapping**

Distributed DoS Attacks

- ❑ **Tribe Flood Network** (TFN) clients are installed on compromised hosts.
- ❑ All clients start a simultaneous DoS attack on a victim on a trigger from the attacker.
- ❑ **Trinoo** attack works similarly. Use UDP packets. Trinoo client report to Trinoo master when the system comes up.
- ❑ **Stacheldraht** uses handlers on compromised hosts to receive encrypted commands from the attacker.

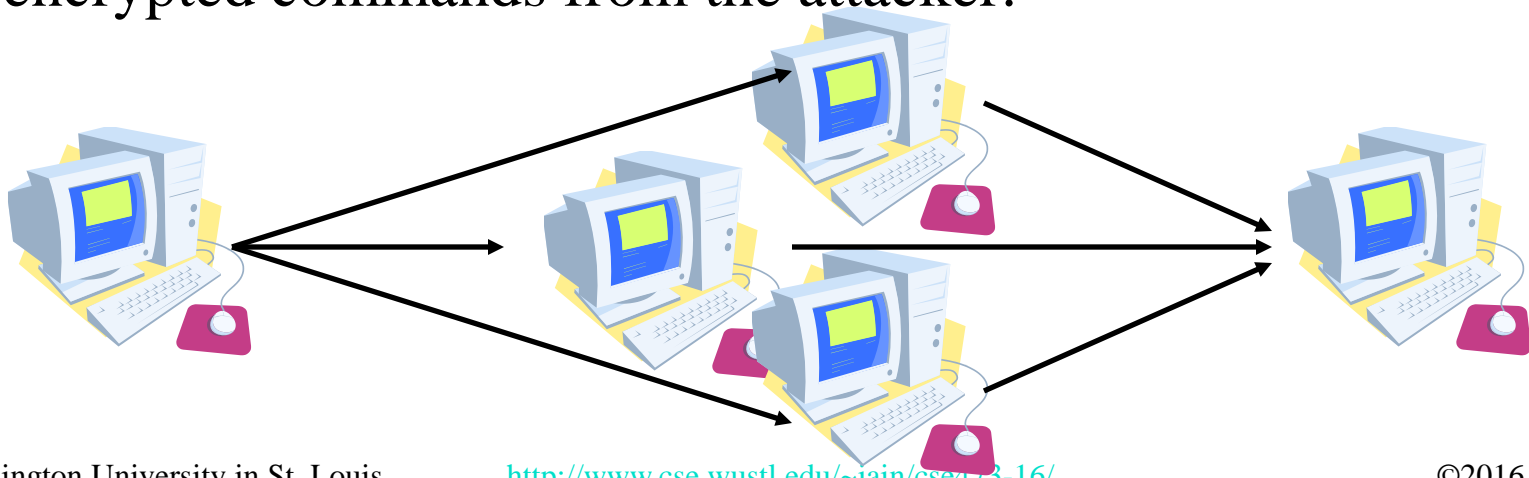

History of Internet

- ❑ **1961:** Kleinrock developed queueing theory. Showed effectiveness of packet-switching
- ❑ **1964:** Baran's report on packet-switching in military nets
- ❑ **1967:** ARPAnet conceived by Advanced Research Projects Agency
- ❑ **1969:** First ARPAnet node operational
First Request for Comment (RFC)
www.ietf.org

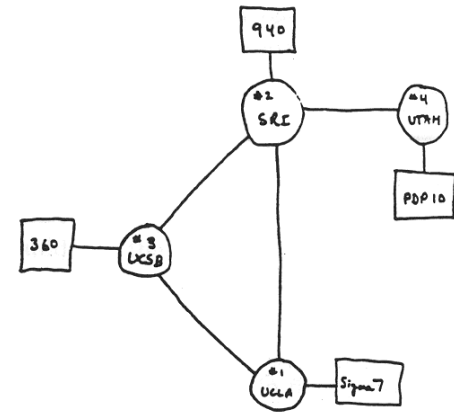

THE ARPA NETWORK

History of Internet (Cont)

- ❑ Early 1990s: HTML, HTTP: Berners-Lee
- ❑ 1994: Mosaic, later Netscape
- ❑ 2007:
 - ❑ ~500 million hosts
 - ❑ Voice, Video over IP
 - ❑ P2P applications: BitTorrent (file sharing) Skype (VoIP), PPLive (video)
 - ❑ Video applications: YouTube, gaming
 - ❑ Wireless, Mobility

Key Concepts

- ❑ **Internet Protocol (IP):** Protocol
- ❑ **Address:** All systems have an IP address, for example, 125.36.47.23
- ❑ **Name:** All systems have a human readable name, e.g., scorio.cec.wustl.edu, ibm.com.
- ❑ Technically called **DNS (domain name systems)** name. Details will be introduced later.
- ❑ **IETF:** Internet Engineering Task Force. Make standards for Internet. IETF.org
- ❑ **RFC:** Request for comments. Documents that describe Internet protocols.

Summary

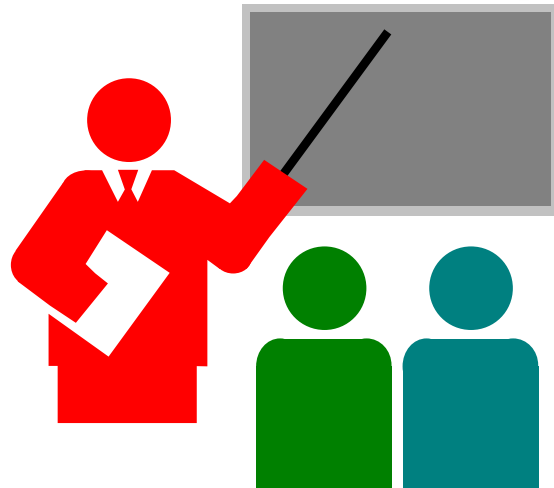

1. Most common medium is UTP, wireless, fiber
2. Internet is a network of networks
3. Enterprise, access, and core networks
4. Performance Measures: Delay, Throughput, Loss Rate
5. Protocol Layers: ISO and TCP/IP reference models

Lab 1

1. Find the IP address of your computer (ipconfig, ifconfig)
2. Find the IP address of www.wustl.edu (ping)
3. Measure delay from your computer to www.wustl.edu (ping or tracert)

For all cases submit the screen snapshot showing the command used and the output. (Use Alt-Print-screen to capture a window to clipboard and then paste to word)

Lab 1 (Cont)

4. Download Wireshark,

<https://www.wireshark.org/download.html>

- ❑ Install it on your laptop.
- ❑ Start wireshark and start logging
- ❑ Tracert to www.google.com
- ❑ Stop logging. Capture the current screen and submit.
Do not worry about the part of the trace that is no longer on the screen.
- ❑ Q1: List 3 protocols that you see in the packet trace.
- ❑ Q2: What is the internet address of www.google.com from the trace?

Scan This to Download These Slides



Raj Jain

<http://rajjain.com>

Related Modules



CSE 473s: Introduction to Computer Networks
(Course Overview),

http://www.cse.wustl.edu/~jain/cse473-16/ftp/i_0int.pdf

CSE473S: Introduction to Computer Networks (Fall 2016),

<http://www.cse.wustl.edu/~jain/cse473-16/index.html>



Wireless and Mobile Networking (Spring 2016),

<http://www.cse.wustl.edu/~jain/cse574-16/index.html>

CSE571S: Network Security (Fall 2014),

<http://www.cse.wustl.edu/~jain/cse571-14/index.html>



Audio/Video Recordings and Podcasts of
Professor Raj Jain's Lectures,

<https://www.youtube.com/channel/UCN4-5wzNP9-ruOzQMs-8NUw>