

The Network Layer: Data Plane

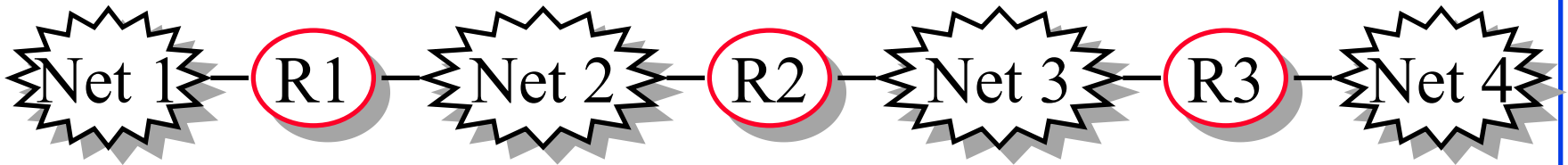

Raj Jain

Washington University in Saint Louis

Saint Louis, MO 63130

Jain@wustl.edu

Audio/Video recordings of this lecture are available on-line at:

<http://www.cse.wustl.edu/~jain/cse473-20/>



1. Network Layer Basics
2. What's inside a router?
3. Forwarding Protocols: IPv4, DHCP, NAT, IPv6
4. Software Defined Networking

Note: This class lecture is based on Chapter 4 of the textbook (Kurose and Ross) and the figures provided by the authors.



Network Layer Basics

1. Forwarding and Routing
2. Connection Oriented Networks: ATM Networks
3. Classes of Service
4. Router Components
5. Packet Queuing and Dropping

Forwarding and Routing

- ❑ **Forwarding:** Input link to output link via Address prefix lookup in a table.
- ❑ **Routing:** Making the Address lookup table
- ❑ **Longest Prefix Match**

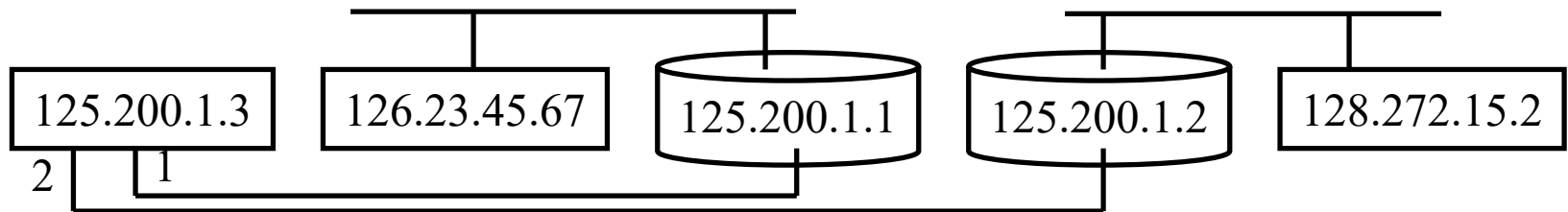

Prefix	Next Router	Interface
126.23.45.67/32	125.200.1.1	1
128.272.15/24	125.200.1.2	2
128.272/16	125.200.1.1	1

Network Service Models

- ❑ Guaranteed Delivery: No packets lost
- ❑ Bounded delay: Maximum delay
- ❑ In-Order packet delivery: Some packets may be missing
- ❑ Guaranteed minimal throughput
- ❑ Guaranteed maximum jitter: Delay variation
- ❑ Security Services (optional in most networks)
- ❑ ATM offered most of these
- ❑ IP offers none of these \Rightarrow Best effort service (Security is optional)

Optional Homework: R4, R5 in the textbook

What's Inside a Router?

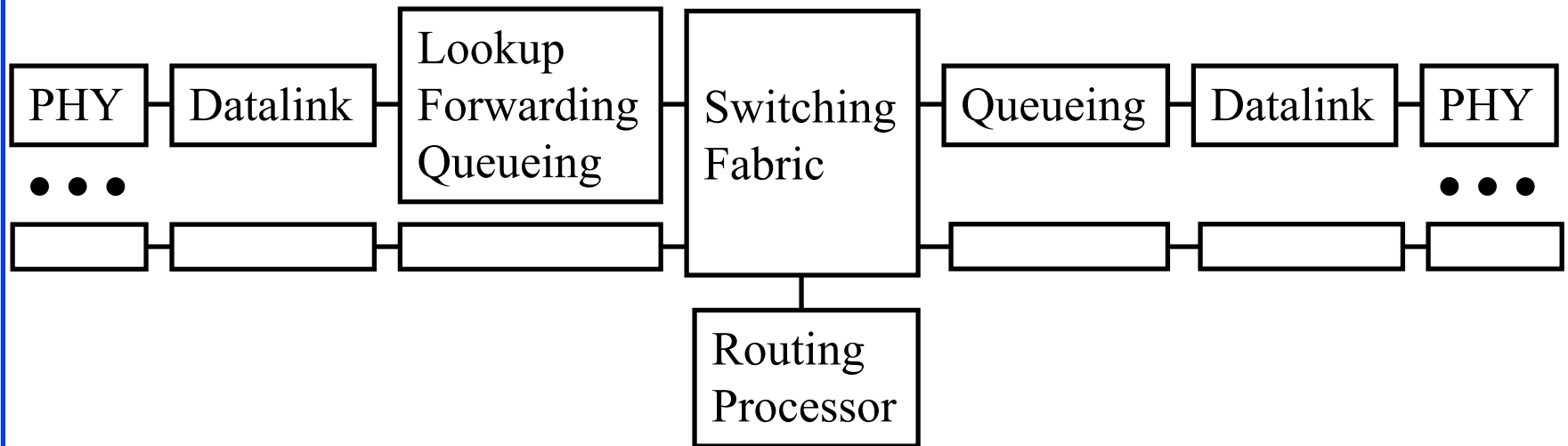

- ❑ **Input Ports:** receive packets, lookup address, queue
Use **Content Addressable Memories** (CAMs) and caching
- ❑ **Switch Fabric:** Send from input port to output port
- ❑ **Output Ports:** Queuing, transmit packets

Types of Switching Fabrics

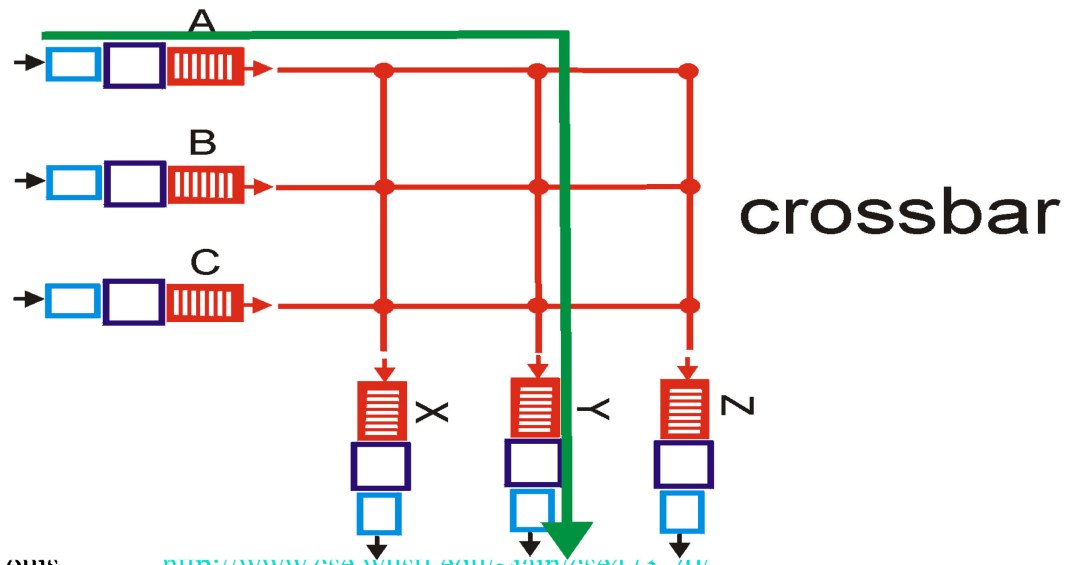
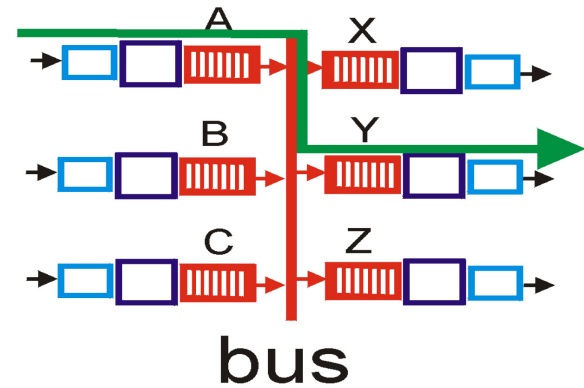
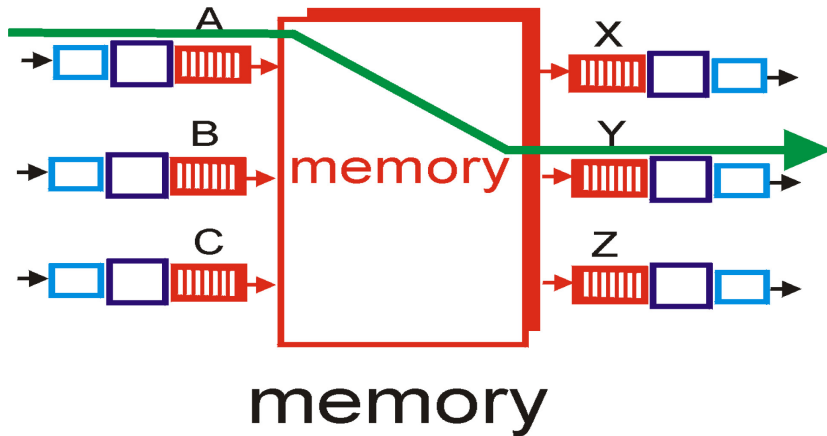

Where Does Queuing Occur?

- ❑ If switching fabric is slow, packets wait on the input port.
- ❑ If switching fabric is fast, packets wait for output port
⇒ Queueing (Scheduling) and drop policies
- ❑ Queueing: First Come First Served (FCFS),
Weighted Fair Queueing

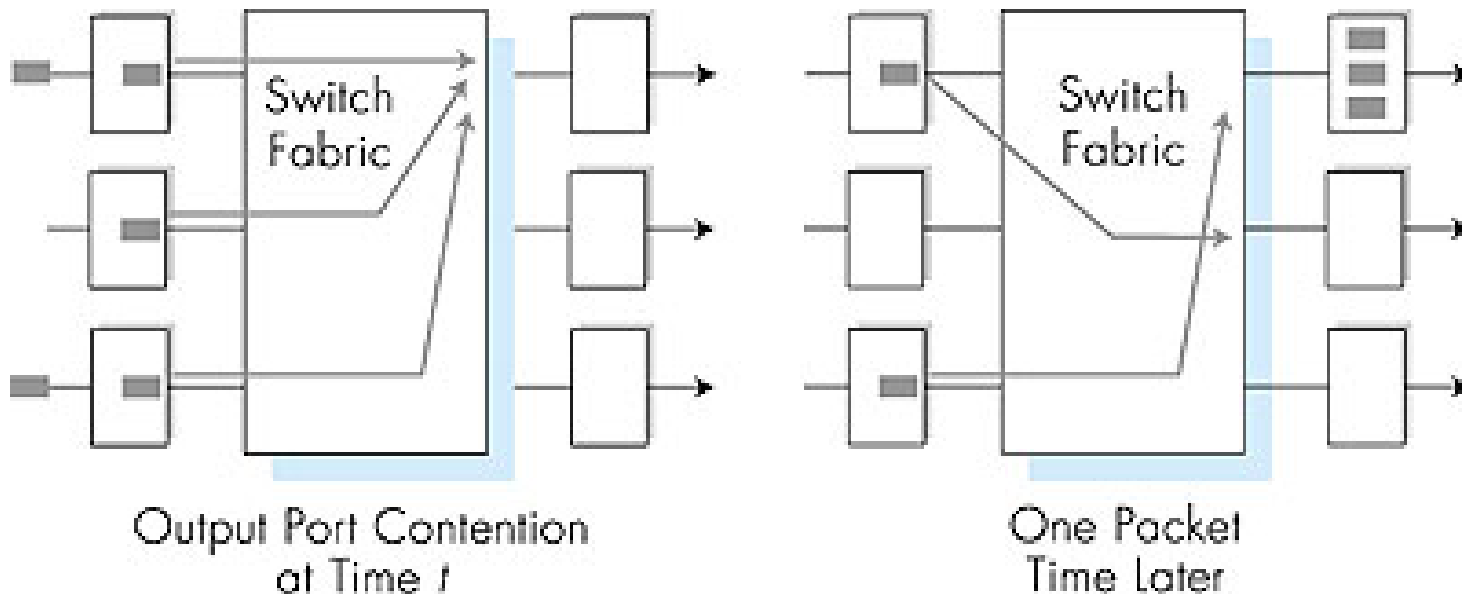

Ideal Buffering

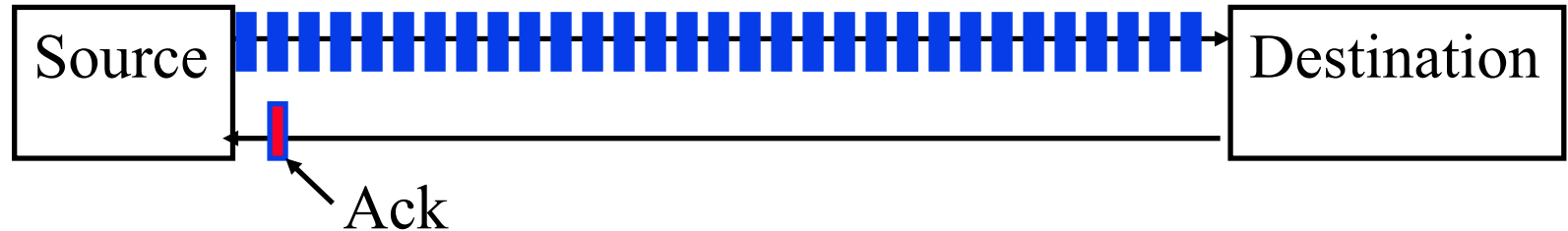

- ❑ Flow Control Buffering = $RTT * \text{Transmission Rate}$
- ❑ Buffer = $RTT * \text{Transmission Rate} / \sqrt{(\# \text{ of TCP flows})}$

Packet Dropping Policies

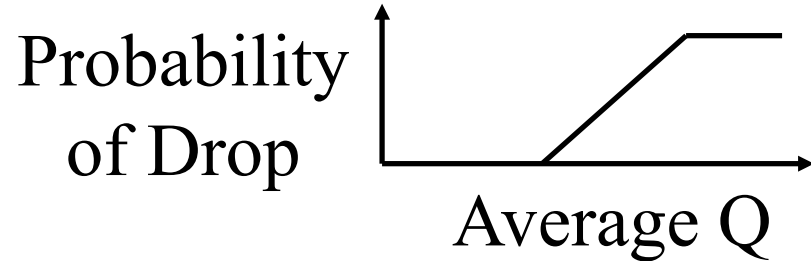
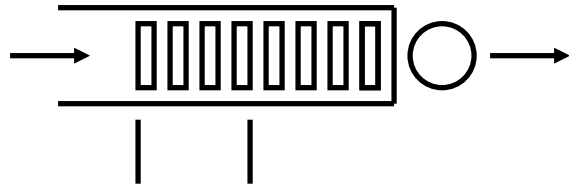

- ❑ **Drop-Tail:** Drop the arriving packet
 - ❑ **Random Early Drop (RED):** Drop arriving packets even before the queue is full
 - Routers measure average queue and drop incoming packet with certain probability
- ⇒ **Active Queue Management (AQM)**

Head-of-Line Blocking

- Packet at the head of the queue is waiting
⇒ Other packets can not be forwarded even if they are going to other destination

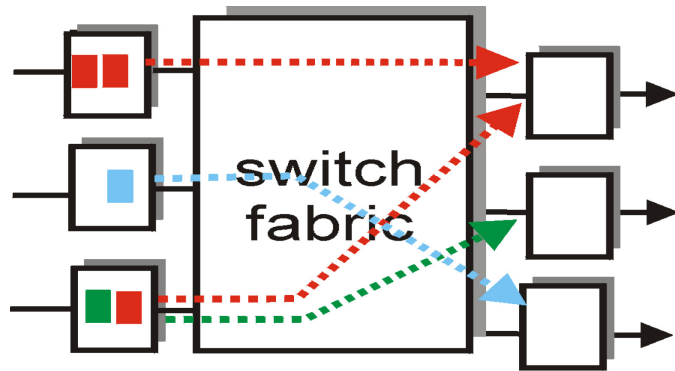

output port contention
at time t - only one red
packet can be transferred

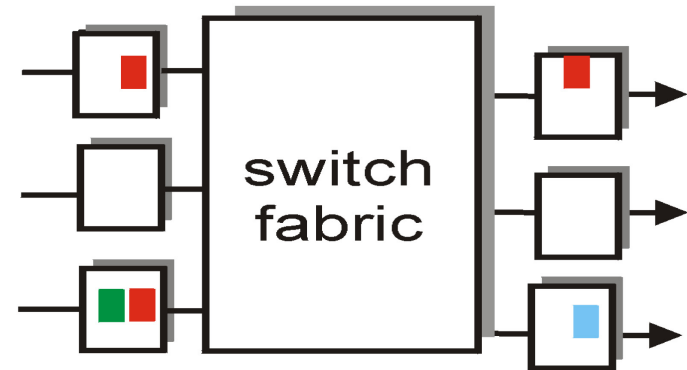

green packet
experiences HOL blocking

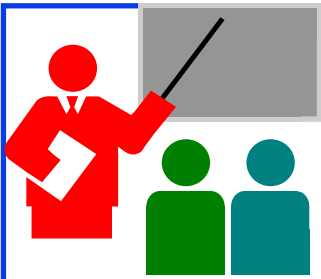

Network Layer Basics: Review

1. Forwarding uses routing table to find output port for datagrams using **longest prefix match**. Routing protocols make the table.
2. IP provides only **best effort** service (KISS).
3. Routers consist of input/output ports, **switching fabric**, and processors.
4. Datagrams may be dropped even if the queues are not full (**Random early drop**).
5. Queueing at input may result in **head of line blocking**.



Forwarding Protocols

1. IPv4 Datagram Format
2. IP Fragmentation and Reassembly
3. IP Addressing
4. Network Address Translation (NAT)
5. Universal Plug and Play
6. Dynamic Host Control Protocol (DHCP)
7. IPv6

IP Datagram Format

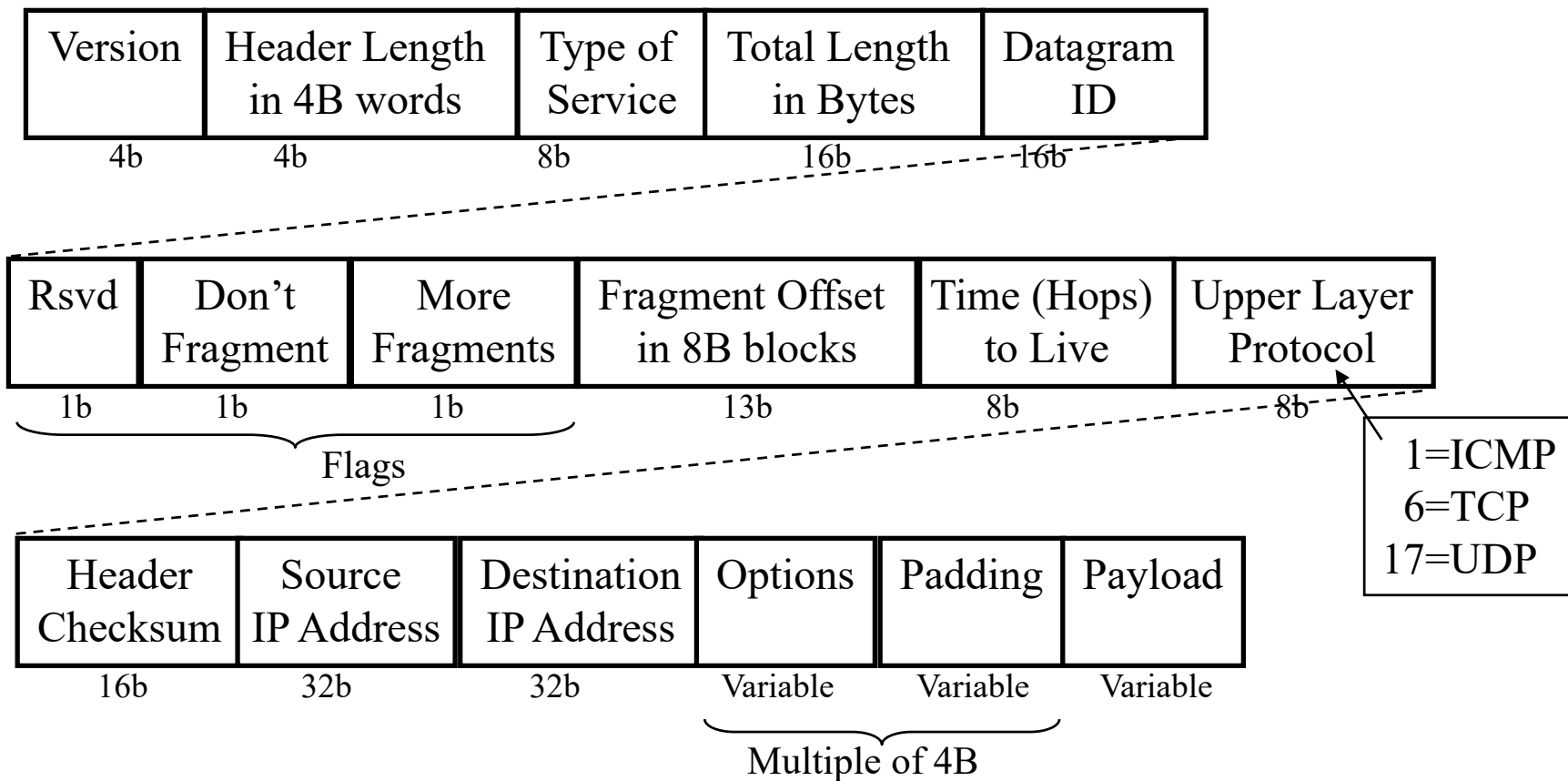

IP Fragmentation Fields

- ❑ Header length: in units of 32-bit words
- ❑ Data Unit Identifier (ID)
 - Sending host puts an identification number in each datagram
- ❑ Total length: Length of user data plus header in bytes
- ❑ Fragment Offset - Position of fragment in original datagram
 - ❑ In multiples of 8 byte blocks
- ❑ *More fragments* flag
 - ❑ Indicates that this is not the last fragment
- ❑ Datagrams can be fragmented/refragmented at any router
- ❑ Datagrams are reassembled only at the destination host

IP Fragmentation and Reassembly

Example

- ❑ 4000 byte datagram
- ❑ Maximum Transmission Unit (MTU) = 1500 bytes

1480 bytes in data field

offset = $1480/8$

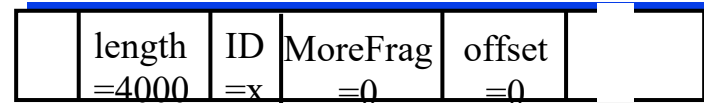

One large datagram becomes several smaller datagrams

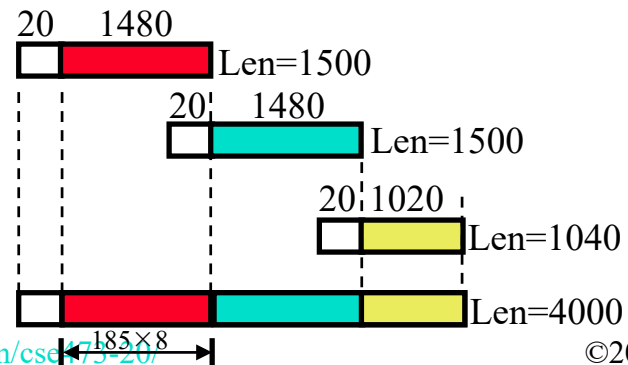
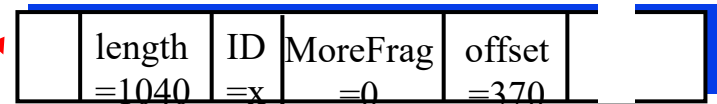
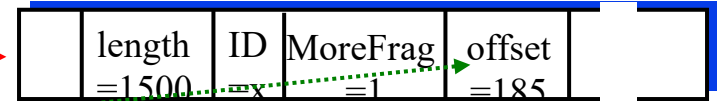
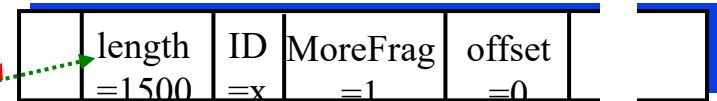

Homework 4A: Fragmentation

- [8 points] Consider sending a 2400-byte datagram into a link that has an MTU of 720 bytes. Suppose the original datagram is stamped with the identification number 422. How many fragments are generated? What are the values in the various fields in the IP datagram(s) generated related to fragmentation?

IP Address Classes

❑ Class A:

0	Network	Local
1	7	24 bits

❑ Class B:

10	Network	Local
2	14	16 bits

❑ Class C:

110	Network	Local
3	21	8 bits

❑ Class D:

1110	Host Group (Multicast)
4	28 bits

❑ Class E:

11110	Future use
5	27 bits

❑ Local = Subnet + Host (Variable length)

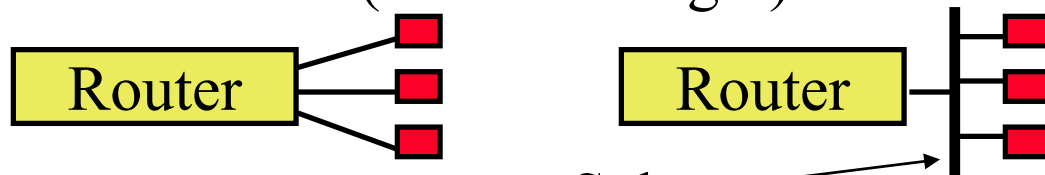

IP Addressing

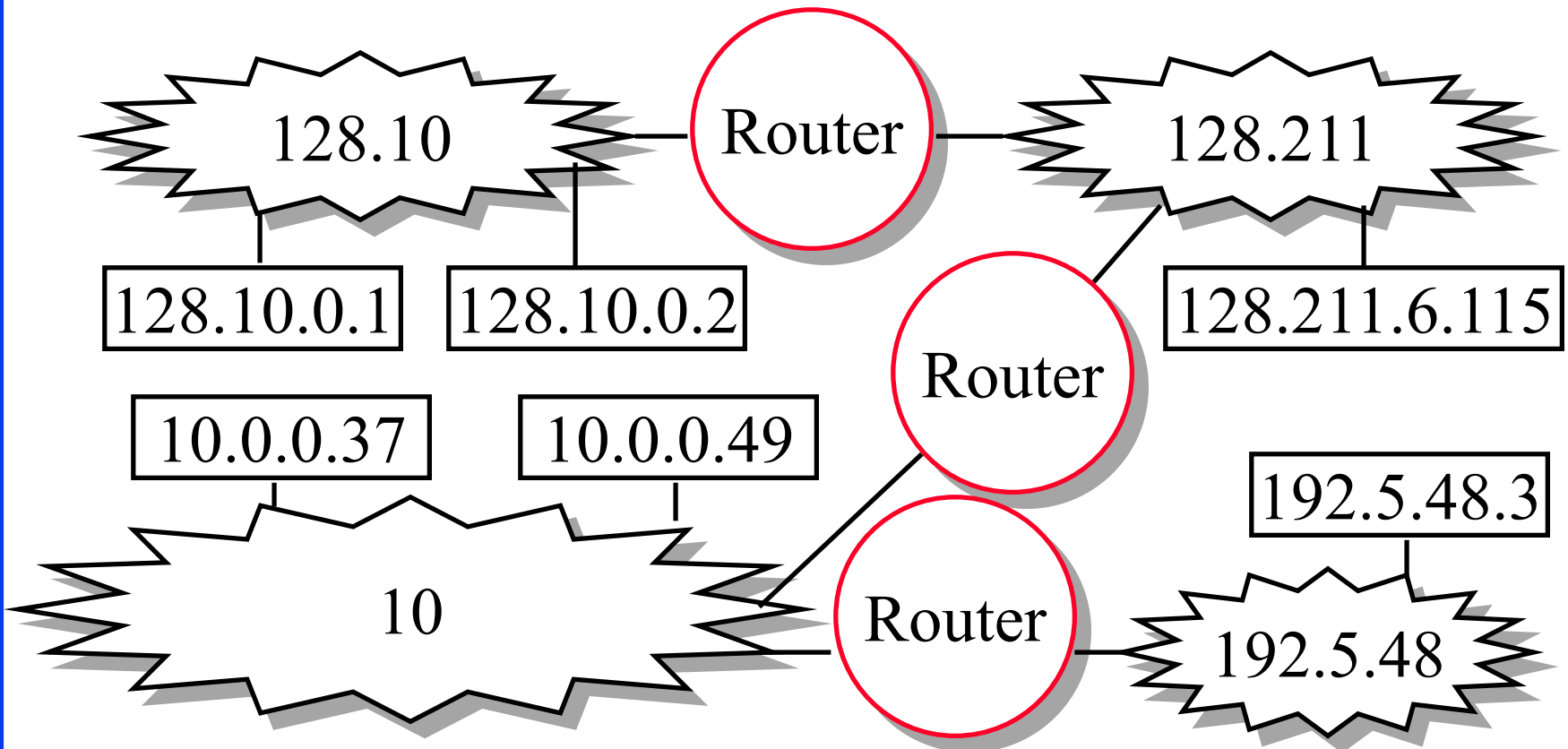

- ❑ All IP hosts have a 32-bit address. 128.10.0.1
= 1000 0000 0000 1010 0000 0000 0000 0001
- ❑ All hosts on a network have the same network prefix

Subnetting

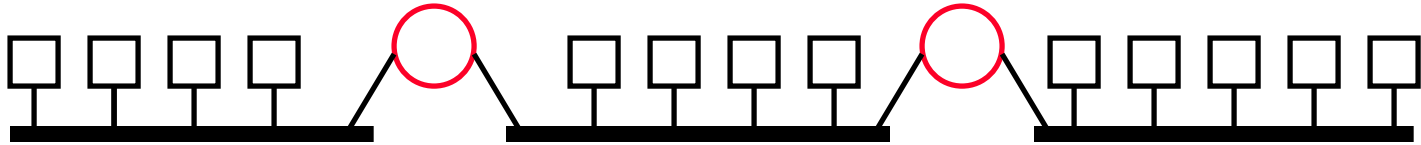

- ❑ All hosts on a subnetwork have the same prefix. Position of the prefix is indicated by a “subnet mask”
- ❑ Example: First 23 bits = subnet
Address: 10010100 10101000 00010000 11110001
Mask: 11111111 11111111 11111110 00000000
.AND. 10010100 10101000 00010000 00000000

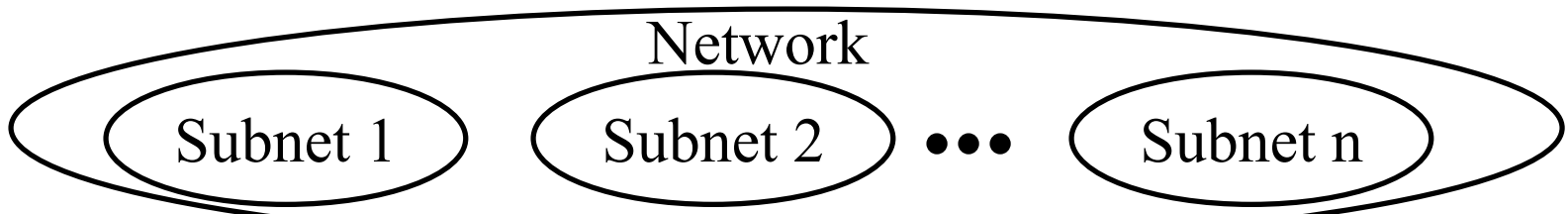

IP addressing: CIDR

□ CIDR: Classless InterDomain Routing

- Subnet portion of address of arbitrary length
- Address format: a.b.c.d/x, where x is # bits in subnet portion of address
- All 1's in the host part is used for subnet broadcast
- All 0's in the host part was meant as “subnet address” but not really used for anything. Some implementation allow it to be used as host address. Some don't. Better to avoid it.



200.23.16.0/23

Homework 4B: Subnets

- [22 points] Consider a router that interconnects 3 subnets: Subnet 1, Subnet 2, and Subnet 3. Suppose all of the interfaces in each of these three subnets are required to have the prefix 223.1.17/24. Also suppose that Subnet 1 is required to support up to 61 interfaces, Subnet 2 is to support up to 96 interfaces, and Subnet 3 is to support up to 16 interfaces. Provide three network address prefixes (of the form a.b.c.d/x) that satisfy these constraints. **Use adjacent allocations.** For each subnet, also list the subnet mask to be used in the hosts.

Forwarding an IP Datagram

- ❑ Delivers **datagrams** to destination network (subnet)
- ❑ Routers maintain a “routing table” of “next hops”
- ❑ Next Hop field does not appear in the datagram

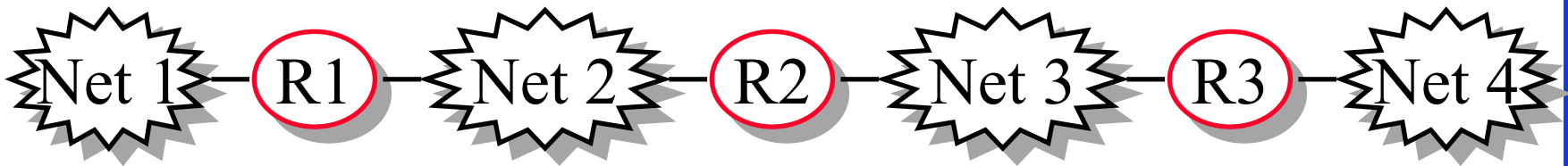

Table at R2:

Destination Next Hop

Net 1	Forward to R1
Net 2	Deliver Direct
Net 3	Deliver Direct
Net 4	Forward to R3

Route Aggregation

- ❑ Can combine two or more prefixes into a shorter prefix
- ❑ ISPs-R-U's has a more specific route to organization 1

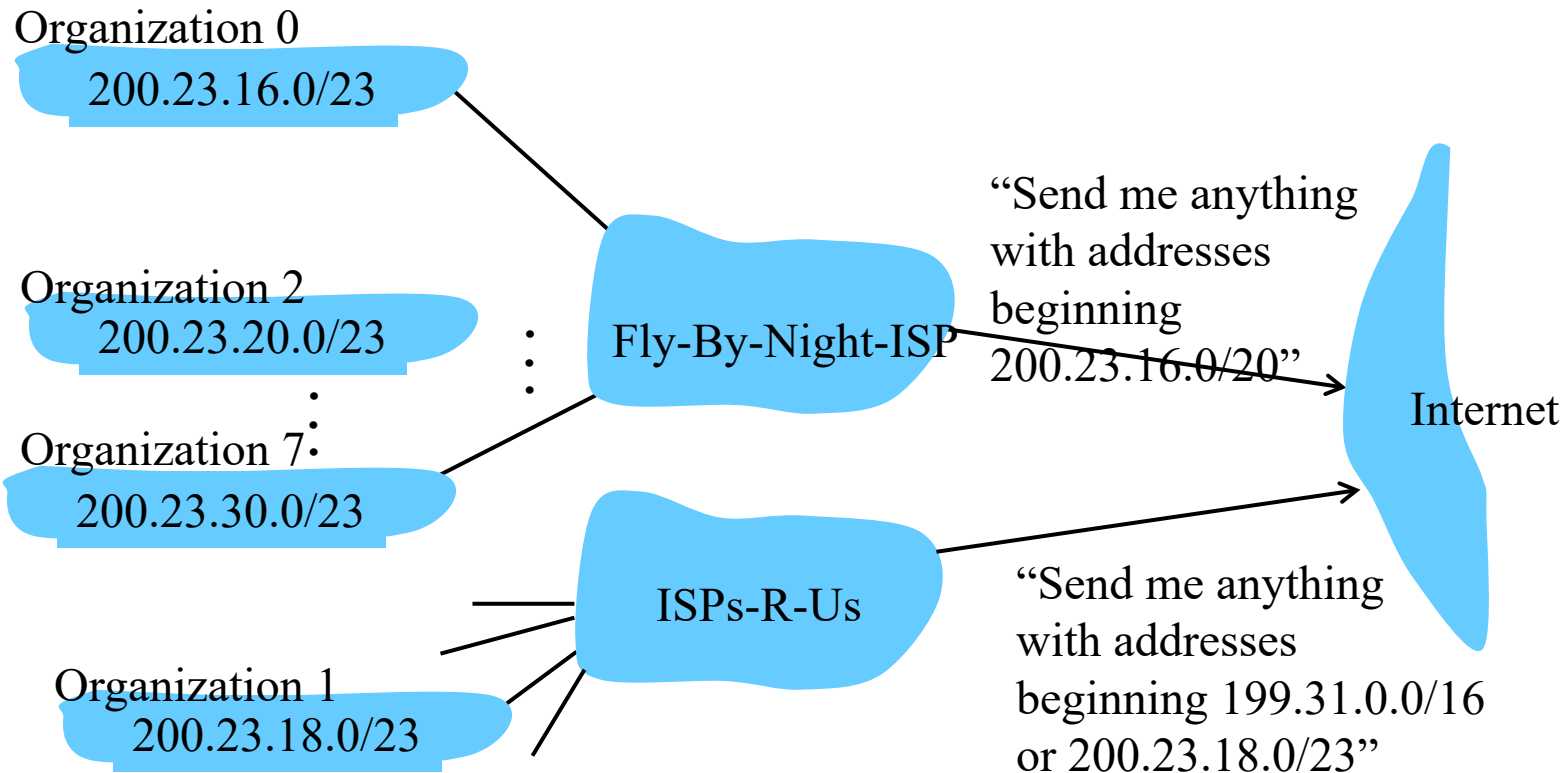

“Route Print” Command in Windows

MAC: netstat -rn

Interface List

```
0x1 ..... MS TCP Loopback interface
0x2 ...00 16 eb 05 af c0 ..... Intel(R) WiFi Link 5350 - Packet Scheduler Miniport
0x3 ...00 1f 16 15 7c 41 ..... Intel(R) 82567LM Gigabit Network Connection - Packet Scheduler Miniport
0x40005 ...00 05 9a 3c 78 00 ..... Cisco Systems VPN Adapter - Packet Scheduler Miniport
```

Active Routes:

Network Destination	Netmask	Gateway	Interface	Metric
0.0.0.0	0.0.0.0	192.168.0.1	192.168.0.108	10
0.0.0.0	0.0.0.0	192.168.0.1	192.168.0.106	10
127.0.0.0	255.0.0.0	127.0.0.1	127.0.0.1	1
169.254.0.0	255.255.0.0	192.168.0.106	192.168.0.106	20
192.168.0.0	255.255.255.0	192.168.0.106	192.168.0.106	10
192.168.0.0	255.255.255.0	192.168.0.108	192.168.0.108	10
192.168.0.106	255.255.255.255	127.0.0.1	127.0.0.1	10
192.168.0.108	255.255.255.255	127.0.0.1	127.0.0.1	10
192.168.0.255	255.255.255.255	192.168.0.106	192.168.0.106	10
192.168.0.255	255.255.255.255	192.168.0.108	192.168.0.108	10
224.0.0.0	240.0.0.0	192.168.0.106	192.168.0.106	10
224.0.0.0	240.0.0.0	192.168.0.108	192.168.0.108	10
255.255.255.255	255.255.255.255	192.168.0.106	192.168.0.106	1
255.255.255.255	255.255.255.255	192.168.0.106	40005	1
255.255.255.255	255.255.255.255	192.168.0.108	192.168.0.108	1

Default Gateway: 192.168.0.1

Adr & mask = Dest
⇒ Match

Longest Prefix match
is used

Metric: Lower is better

Persistent Routes:

None

Note: 127.0.0.1 = Local Host, 224.x.y.z = Multicast on local LAN

Lab 4A: Routing Table

- ❑ [8 Points] Use “Route Help” in Windows (or man route in MAC) to learn the route command
- ❑ Ping www.google.com to find its address
- ❑ Make sure that you have two active interfaces preferably connected to different routers. For example, create a 2nd interface by connecting a smart phone hot spot via USB. Or by connecting to a router in our lab during TA hours
- ❑ Print route table
- ❑ Trace route to www.google.com using tracert
- ❑ Modify the routing table so that the other interface will be used.
- ❑ Note the command you used to modify the routing table
- ❑ Print the new routing table
- ❑ Trace route to the same numeric address for www.google.com as before . Submit underlined items.

Lab 4A Hints

- ❑ A host with two interfaces going to the same router:

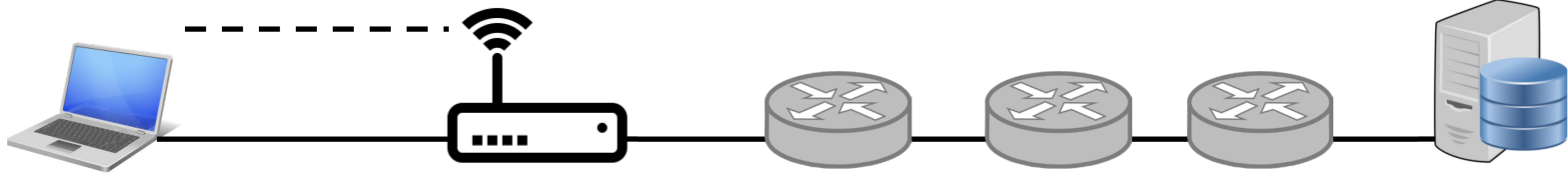

- ❑ Trace route result will not change even if you change the interface.

```
IPv4 Route Table
-----
Active Routes:
Network Destination        Netmask          Gateway          Interface        Metric
-----
0.0.0.0                    0.0.0.0          192.168.0.1     192.168.0.152    55
0.0.0.0                    0.0.0.0          192.168.0.1     192.168.0.151    25
```

Lab 4A Hints (Cont)

- ❑ If you have two routers, you can see the effect in trace route. One way to get two routers is to use your cell phone hot spot:

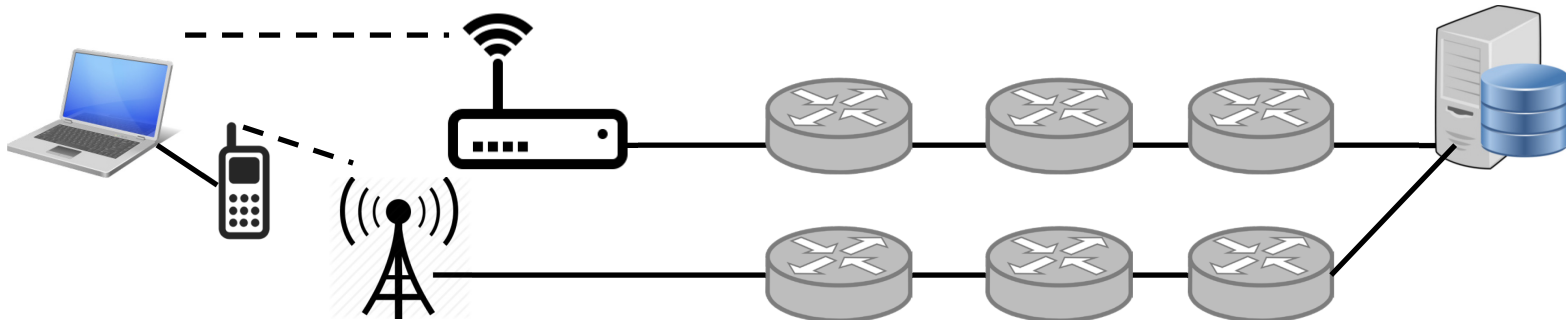

```
IPv4 Route Table
-----
Active Routes:
Network Destination        Netmask          Gateway          Interface        Metric
-----
0.0.0.0                    0.0.0.0         192.168.0.1     192.168.0.151   25
0.0.0.0                    0.0.0.0         172.20.10.1     172.20.10.2    35
```

- ❑ WiFi on phone should be disabled to ensure that it does not forward the traffic to the same home router.

Lab 4A Hints (Cont)

- Another way to get two routers is to use another router. We have placed an extra router in our lab.

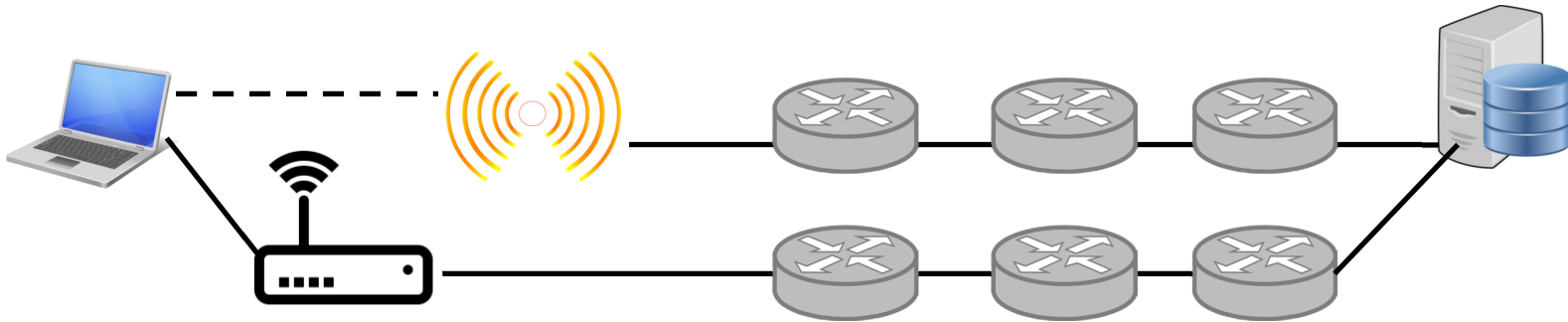

```
IPv4 Route Table
-----
Active Routes:
Network Destination    Netmask          Gateway          Interface        Metric
0.0.0.0                0.0.0.0         192.168.0.1     192.168.0.151    25
0.0.0.0                0.0.0.0         172.20.10.1     172.20.10.2     35
```

Lab 4A Hints (Cont)

- ❑ WWW.google.com may have different IP addresses on different networks and so trace route to the same numeric address.
- ❑ WUSTL VPN rejects all traffic not going to WUSTL. So it can not be used as the 2nd interface.
- ❑ The new metric assigned by the route command may not be what you specified. So always check using route print.

Lab 4A Hints (Cont)

A. Use “route help” to learn the route command

- ❑ **Windows:** route help
- ❑ **Linux:** route help
- ❑ **MAC:**
 - man netstat
 - man route

B. Ping www.google.com to find its address

- ping www.google.com

C. Print the new routing table

- ❑ **Windows:**
 - route print
- ❑ **Linux:**
 - route
- ❑ **MAC:**
 - netstat -nr

D. Modify routing tables

- ❑ **Windows:**
 - route add/delete/change
- ❑ **Linux:**
 - route add/del
- ❑ **MAC:**
 - sudo route -nv add

E. Verify using tracert

- ❑ **Windows:**
 - tracert
- ❑ **Linux:**
 - traceroute
- ❑ **MAC:**
 - traceroute

Private Addresses

- ❑ Any organization can use these inside their network
Can't go on the internet. [RFC 1918]
- ❑ 10.0.0.0 - 10.255.255.255 (10/8 prefix)
- ❑ 172.16.0.0 - 172.31.255.255 (172.16/12 prefix)
- ❑ 192.168.0.0 - 192.168.255.255 (192.168/16 prefix)

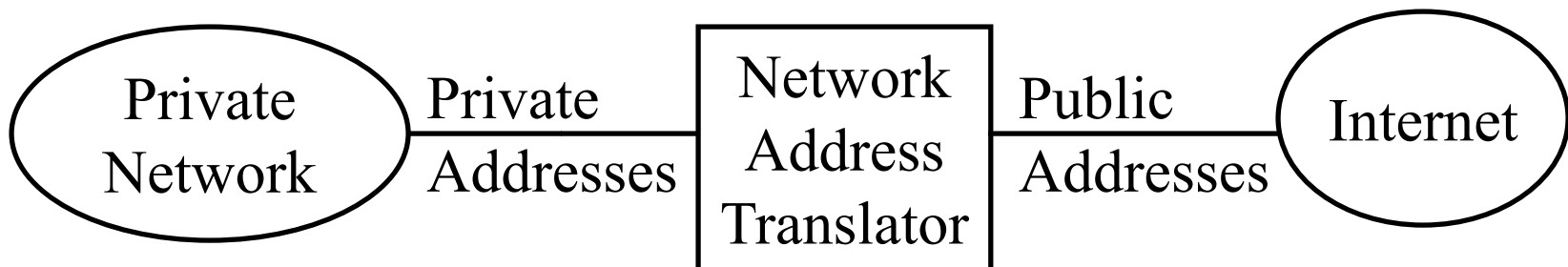

Network Address Translation (NAT)

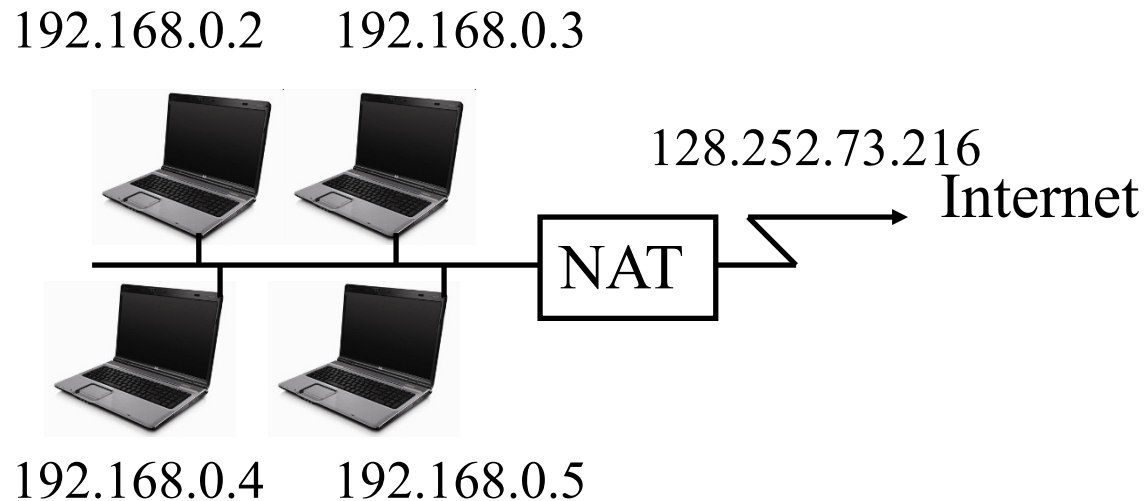

- ❑ Private IP addresses 192.168.x.x
- ❑ Can be used by anyone inside their networks
- ❑ Cannot be used on the public Internet
- ❑ NAT overwrites source addresses on all outgoing packets and overwrites destination addresses on all incoming packets
- ❑ Only outgoing connections are possible

Universal Plug and Play

- ❑ NAT needs to be manually programmed to forward external requests
- ❑ UPnP allows hosts to request port forwarding
- ❑ Both hosts and NAT should be UPnP aware
- ❑ Host requests forwarding all port xx messages to it
- ❑ NAT returns the public address and the port #.
- ❑ Host can then announce the address and port # outside
- ❑ Outside hosts can then reach the internal host (server)

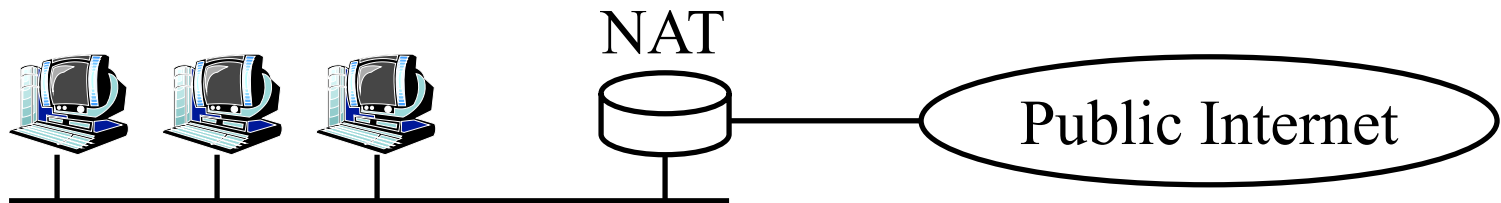

Homework 4C: NAT

- ❑ [4 points] Consider a home network of 3 computers connected to the Internet via a NAT router. Suppose the ISP assigns the router the address 23.34.112.235 and that the network address of the home network is 192.168.1/29.
- ❑ A. Assign addresses to all interfaces in the home network starting with the lowest possible address.
- ❑ B. What is the subnet mask for the home computers?
- ❑ C. Suppose each host has two ongoing TCP connections, all to port 80 at host 128.119.40.86. Provide the six corresponding entries in the NAT translation table. Both NAT and computers use source ports starting at 3000.

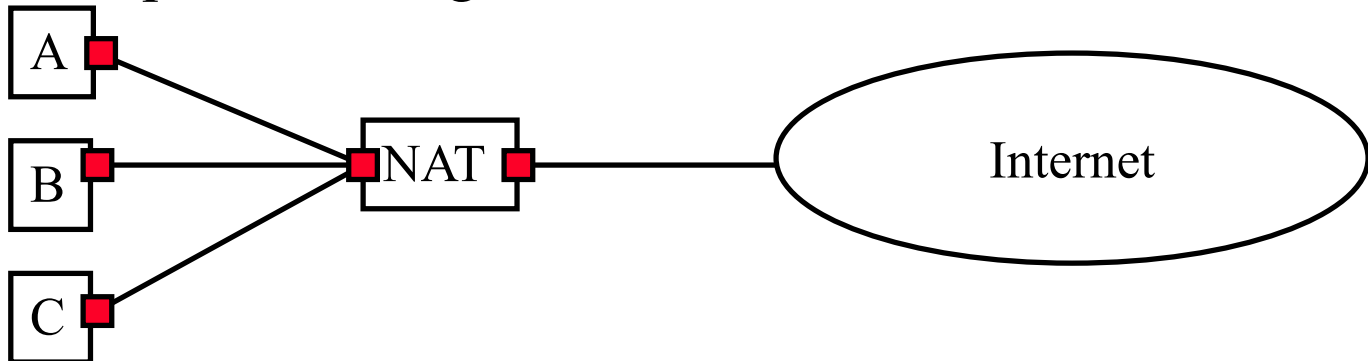

DHCP

- ❑ Dynamic Host Control Protocol
- ❑ Allows hosts to get an IP address automatically from a server
- ❑ Do not need to program each host manually
- ❑ Each allocation has a limited “lease” time
- ❑ Can reuse a limited number of addresses
- ❑ Hosts broadcast “Is there a DHCP Server Here?”
Sent to 255.255.255.255
- ❑ DHCP servers respond

DHCP Example

DHCP server: 223.1.2.5

arriving
client

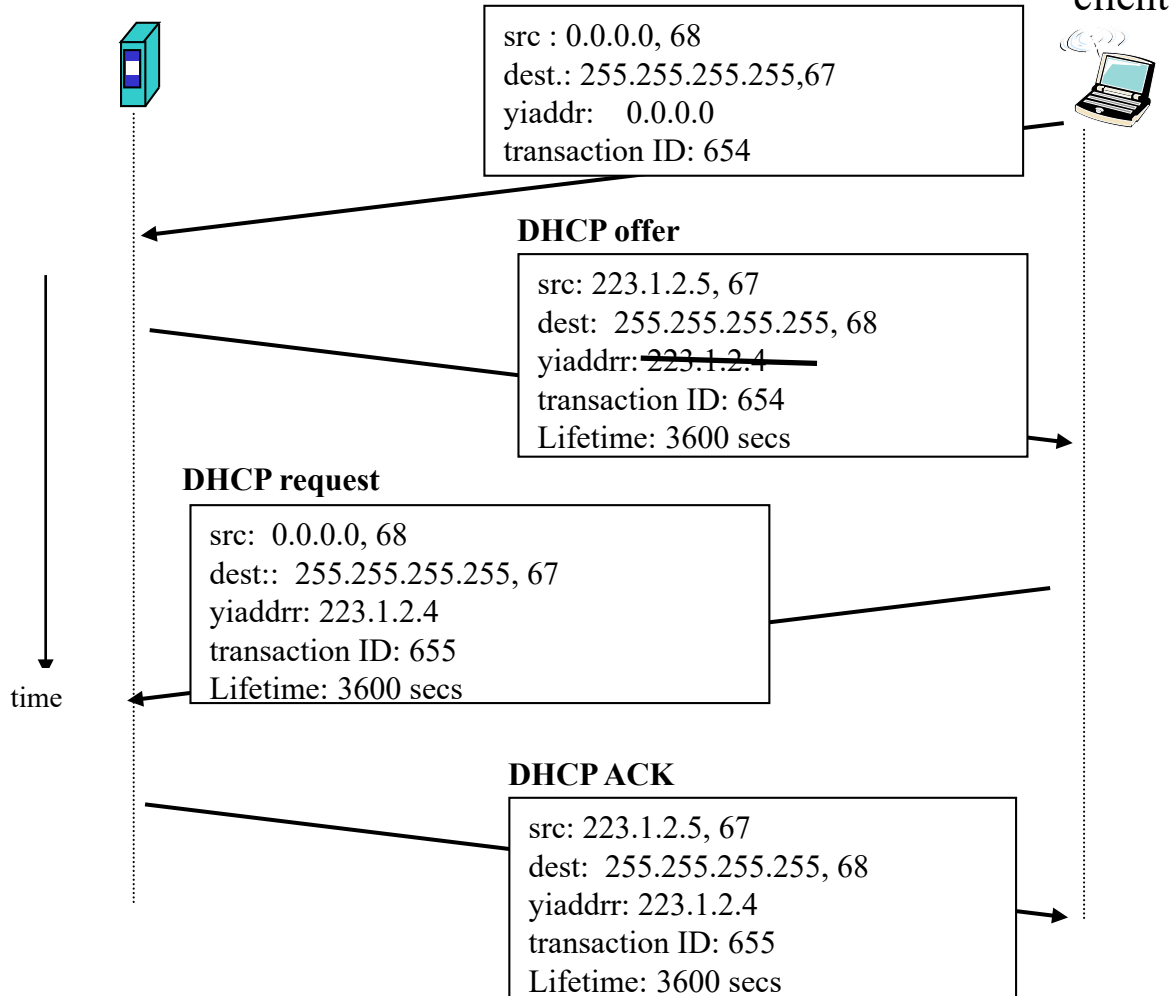

Lab 4B: DHCP

- ❑ [15 points] Download the Wireshark traces from <http://gaia.cs.umass.edu/wireshark-labs/wireshark-traces.zip>
- ❑ Open *dhcp-ethereal-trace-1* in Wireshark. Select **View → Expand All**. Answer the following questions:
 1. Examine Frame 2 marked DHCP.
 - A. What transport protocol and destination port # is used by DHCP?
 - B. What are the source and destination IP addresses for this frame and why?
 - C. What is the **Type-Length-Value** for the DHCP Discover option?
 2. Examine Frames 4, 5, 6 to find Type-Length-Value for:
 - A. DHCP Offer
 - B. DHCP Request
 - C. DHCP Ack

Lab 4B: DHCP (Cont)

3. Examine Frame 4:

- A. What IP address was assigned by the DHCP server?
- B. What IP address is this frame addressed to and why?
- C. What other information was provided by the DHCP server?

- 1. Subnet Mask:

- 2. Default Gateway:

- 3. DNS1:

- 4. DNS2:

- 5. Domain Name:

- 6. Lease Time:

4. Examine Frame 5 and find what preferred IP address was requested by the client?

IPv6

- ❑ Shortage of IPv4 addresses \Rightarrow Need larger addresses
- ❑ IPv6 was designed with 128-bit addresses
- ❑ $2^{128} = 3.4 \times 10^{38}$ addresses
 $\Rightarrow 665 \times 10^{21}$ addresses per sq. m of earth surface
- ❑ If assigned at the rate of $10^6/\mu\text{s}$, it would take 20 years
- ❑ **Dot-Decimal:** 127.23.45.88
- ❑ **Colon-Hex:** FEDC:0000:0000:0000:3243:0000:0000:ABCD
 - Can skip leading zeros of each word
 - Can skip one sequence of zero words, e.g.,
FEDC::3243:0000:0000:ABCD
::3243:0000:0000:ABCD
 - Can leave the last 32 bits in dot-decimal, e.g., ::127.23.45.88
 - Can specify a prefix by /length, e.g., 2345:BA23:0007::/50

IPv6 Header

□ IPv6:

Version (4b)	Traffic Class (8b)	Flow Label (20b)	
Payload Length (16b)		Next Header (8b)	Hop Limit (8b)
Source Address (128b)			
Destination Address (128b)			

□ IPv4:

Version	IHL	Type of Service	Total Length
Identification		Flags	Fragment Offset
Time to Live	Protocol	Header Checksum	
Source Address			
Destination Address			
Options			Padding

IPv6 vs. IPv4

- ❑ 1995 vs. 1975
- ❑ IPv6 only twice the size of IPv4 header
- ❑ Only version number has same position and meaning as in IPv4
- ❑ Removed: header length, type of service, identification, flags, fragment offset, header checksum ⇒ No fragmentation
- ❑ Datagram length replaced by payload length
- ❑ Protocol type replaced by next header
- ❑ Time to live replaced by hop limit
- ❑ Added: Priority and flow label
- ❑ All fixed size fields.
- ❑ No optional fields. Replaced by extension headers.
- ❑ 8-bit hop limit = 255 hops max (Limits looping)
- ❑ Next Header = 6 (TCP), 17 (UDP)

IPv4 to IPv6 Transition

- ❑ **Dual Stack:** Each IPv6 router also implements IPv4
IPv6 is used only if source host, destination host, and all routers on the path are IPv6 aware.
- ❑ **Tunneling:** The last IPv6 router puts the entire IPv6 datagram in a new IPv4 datagram addressed to the next IPv6 router
= **Encapsulation**

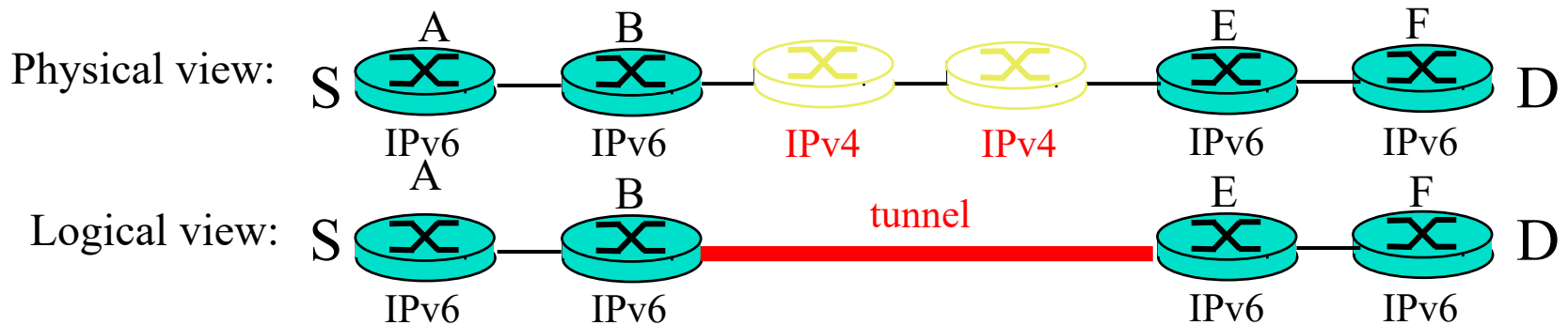

IPv4 From: B to E

IPv6 From: S to D

Data

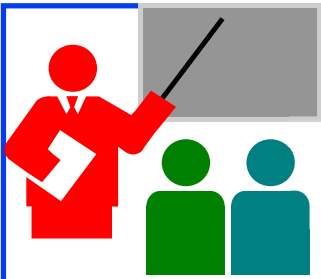

Forwarding Protocols: Review

1. IPv4 uses 32 bit addresses consisting of **subnet + host**
2. **Private addresses** can be reused
⇒ Helped solve the address shortage to a great extent
3. **DHCP** is used to automatically allocate addresses to hosts
4. IPv6 uses **128 bit addresses**. Requires dual stack or **tunneling** to coexist with IPv4.

Ref: Read Section 4.3 of the textbook. Try R17 through R29.

Washington University in St. Louis

<http://www.cse.wustl.edu/~jain/cse473-20/>

©2020 Raj Jain

Generalized Forwarding and SDN

- ❑ Planes of Networking
- ❑ Data vs. Control Logic
- ❑ OpenFlow Protocol

Planes of Networking

- ❑ **Data Plane:** All activities involving as well as resulting from data packets sent by the end user, e.g.,
 - Forwarding
 - Fragmentation and reassembly
 - Replication for multicasting
- ❑ **Control Plane:** All activities that are necessary to perform data plane activities but do not involve end-user data packets
 - Making routing tables
 - Setting packet handling policies (e.g., security)
 - Base station beacons announcing availability of services

Ref: Open Data Center Alliance Usage Model: Software Defined Networking Rev 1.0,”

http://www.opendatacenteralliance.org/docs/Software_Defined_Networking_Master_Usage_Model_Rev1.0.pdf

Planes of Networking (Cont)

- ❑ **Management Plane:** All activities related to provisioning and monitoring of the networks
 - Fault, Configuration, Accounting, Performance and Security (**FCAPS**).
 - Instantiate new devices and protocols (Turn devices on/off)
 - Optional ⇒ May be handled manually for small networks.
- ❑ **Services Plane:** Middlebox services to improve performance or security, e.g.,
 - Load Balancers, Proxy Service, Intrusion Detection, Firewalls, SSL Off-loaders
 - Optional ⇒ Not required for small networks

Data vs. Control Logic

- ❑ Data plane runs at line rate,
e.g., 100 Gbps for 100 Gbps Ethernet \Rightarrow Fast Path
 \Rightarrow Typically implemented using special hardware,
e.g., Ternary Content Addressable Memories (TCAMs)
- ❑ Some exceptional data plane activities are handled by the CPU
in the switch \Rightarrow Slow path
e.g., Broadcast, Unknown, and Multicast (BUM) traffic
- ❑ All control activities are generally handled by CPU

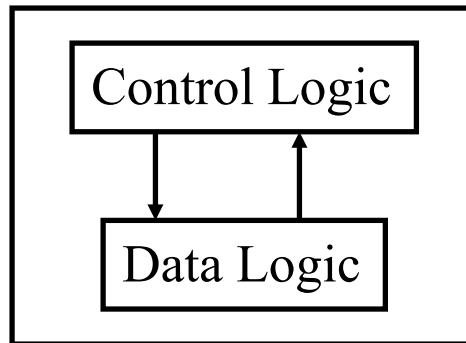

OpenFlow: Key Ideas

1. Separation of control and data planes
2. Centralization of control
3. Flow based control

Ref: N. McKeown, et al., "OpenFlow: Enabling Innovation in Campus Networks," ACM SIGCOMM CCR, Vol. 38, No. 2, April 2008, pp. 69-74.

Washington University in St. Louis <http://www.cse.wustl.edu/~jain/cse473-20/>

©2020 Raj Jain

Separation of Control and Data Plane

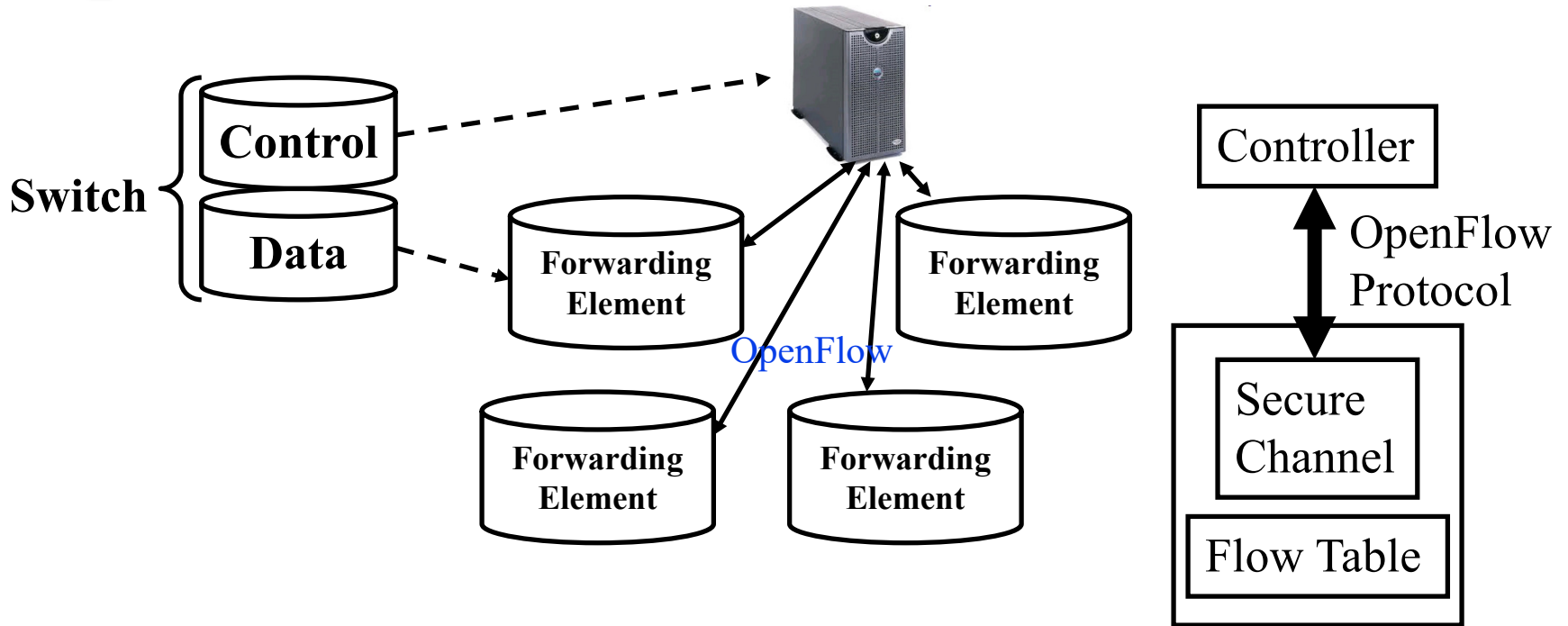

- ❑ Control logic is moved to a controller
- ❑ Switches only have forwarding elements
- ❑ One expensive controller with a lot of cheap switches
- ❑ OpenFlow is the protocol to send/receive forwarding rules from controller to switches

OpenFlow V1.0

- On packet arrival, match the header fields with flow entries in a table, if any entry matches, perform indicated actions, and update the counters indicated in that entry

Flow Table:

Header Fields	Actions	Counters
Header Fields	Actions	Counters
...
Header Fields	Actions	Counters

Ingress Port	Ether Source	Ether Dest	VLAN ID	VLAN Priority	IP Src	IP Dst	IP Proto	IP ToS	Src L4 Port	Dst L4 Port
--------------	--------------	------------	---------	---------------	--------	--------	----------	--------	-------------	-------------

Ref: <http://archive.openflow.org/documents/openflow-spec-v1.0.0.pdf>

Washington University in St. Louis

<http://www.cse.wustl.edu/~jain/cse473-20/>

©2020 Raj Jain

Flow Table Example

Port	Src MAC	Dst MAC	VLAN ID	Priority	EtherType	Src IP	Dst IP	IP Proto	IP ToS	Src L4 Port ICMP Type	Dst L4 Port ICMP Code	Action	Counter
*	*	0A:C8:*	*	*	*	*	*	*	*	*	*	Port 1	102
*	*	*	*	*	*	*	192.168.*.*	*	*	*	*	Port 2	202
*	*	*	*	*	*	*	*	*	*	21	21	Drop	420
*	*	*	*	*	*	*	*	0x806	*	*	*	Local	444
*	*	*	*	*	*	*	*	0x1*	*	*	*	Controller	1

- ❑ Idle timeout: Remove entry if no packets received for this time
- ❑ Hard timeout: Remove entry after this time
- ❑ If both are set, the entry is removed if either one expires.

Ref: S. Azodolmolky, "Software Defined Networking with OpenFlow," Packt Publishing, October 2013, 152 pp., ISBN:978-1-84969-872-6 (Safari Book)

Matching

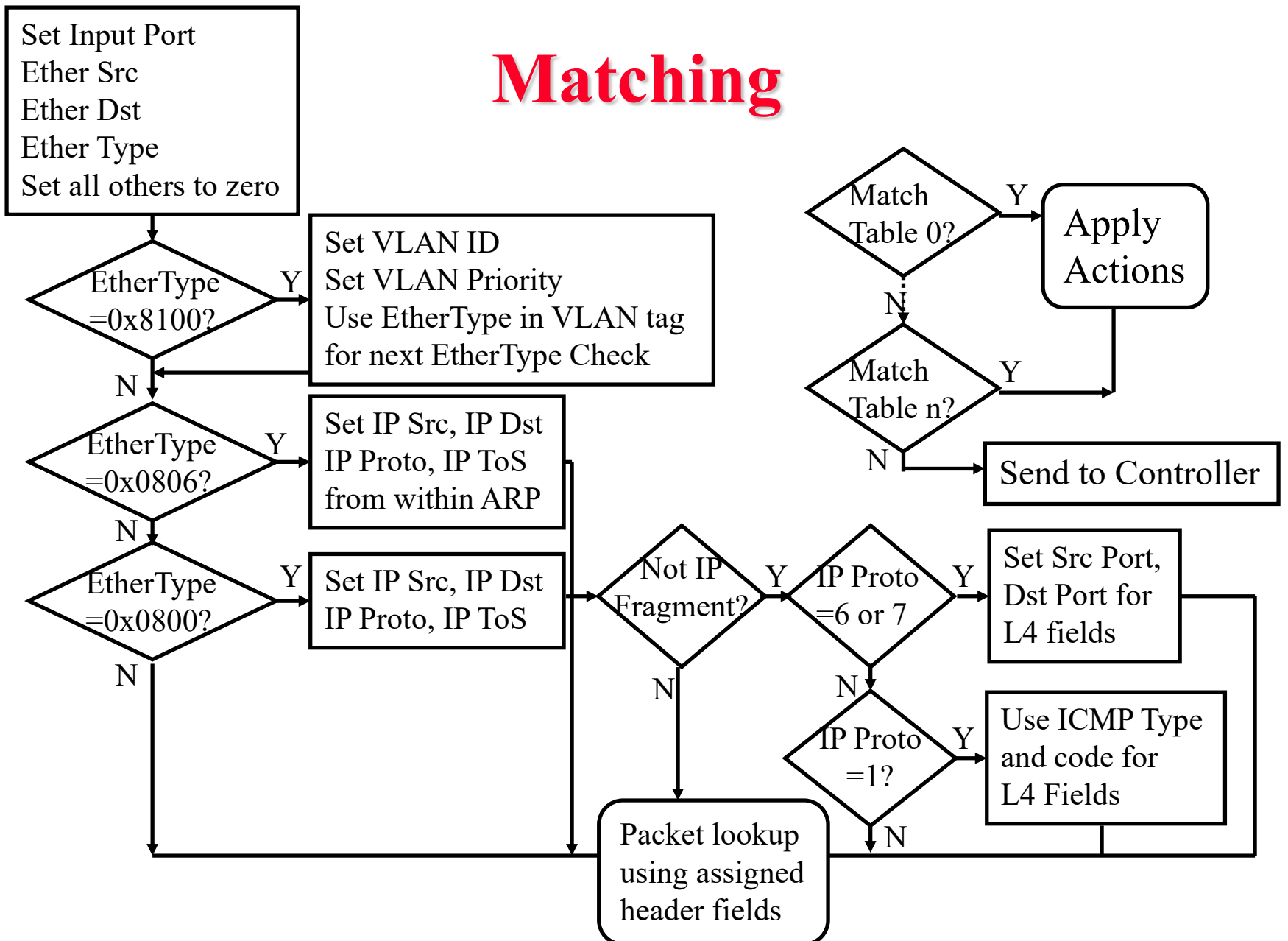

Counters

Per Table	Per Flow	Per Port	Per Queue
Active Entries	Received Packets	Received Packets	Transmit Packets
Packet Lookups	Received Bytes	Transmitted Packets	Transmit Bytes
Packet Matches	Duration (Secs)	Received Bytes	Transmit overrun errors
	Duration (nanosecs)	Transmitted Bytes	
		Receive Drops	
		Transmit Drops	
		Receive Errors	
		Transmit Errors	
		Receive Frame Alignment Errors	
		Receive Overrun errors	
		Receive CRC Errors	
		Collisions	

Actions

- ❑ Forward to Physical/**Virtual Port i**
- ❑ Enqueue: To a particular **queue** in the port \Rightarrow QoS
- ❑ Drop
- ❑ Modify Field: E.g., add/remove VLAN tags, ToS bits, Change TTL
- ❑ Masking allows matching only selected fields, e.g., Dest. IP, Dest. MAC, etc.
- ❑ If header matches an entry, corresponding actions are performed and counters are updated
- ❑ If no header match, the packet is queued and the **header is sent to the controller**, which sends a new rule. Subsequent packets of the flow are handled by this rule.
- ❑ Secure Channel: Between controller and the switch using TLS

Actions (Cont)

- ❑ Modern switches already implement flow tables, typically using Ternary Content Addressable Memories (TCAMs)
- ❑ Controller can change the forwarding rules if a client moves
⇒ Packets for mobile clients are forwarded correctly
- ❑ Controller can send flow table entries beforehand (**Proactive**) or Send on demand (**Reactive**). OpenFlow allows both models.

SDN Data Plane: Summary

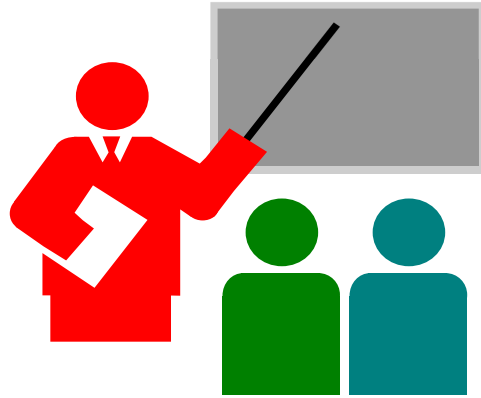

1. **Data plane** consists of packets sent by the users
2. OpenFlow separates data plane from the **control plane** and centralizes the control plane
3. The **controller** makes rules for forwarding and sends to switches
4. Switches match the rules and take specified actions

Network Layer Data Plane: Summary

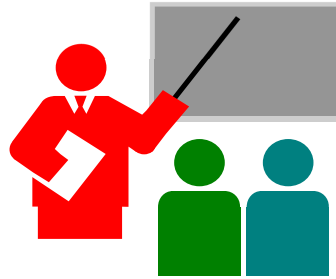

1. **Forwarding** consists of matching the destination address to a list of entries in a table. **Routing** consists of making that table.
2. IP is a forwarding protocol. IPv4 uses 32 bit addresses in **dot-decimal notation**. IPv6 uses 128 bit addresses in **Hex-Colon notation**.
3. **DHCP** is used to assign addresses dynamically.
4. **Private addresses** are used inside an enterprise network. **NAT** allows a single public address to be used by many internal hosts with private addresses.
5. **OpenFlow** separates data plane from control plane and centralizes the control plane

Acronyms

- ❑ ACK Acknowledgement
- ❑ ACM Automatic Computing Machinery
- ❑ AQM Active Queue Management
- ❑ ARP Address Resolution Protocol
- ❑ ATM Asynchronous Transfer Mode
- ❑ BGP Border Gateway Protocol
- ❑ BUM Broadcast, Unknown, and Multicast
- ❑ CAMs Content Addressable Memories
- ❑ CBR Constant bit rate
- ❑ CCR Computer Communications Review
- ❑ CIDR Classless Inter-Domain Routing
- ❑ CPU Central Processing Unit
- ❑ DHCP Dynamic Host Control Protocol
- ❑ DNS Domain Name Service
- ❑ FCAPS Fault, Configuration, Accounting, Performance and Security
- ❑ FCFS First Come First Served

Acronyms (Cont)

- ❑ FTP File Transfer Protocol
- ❑ GFR Guaranteed Frame Rate
- ❑ HTTP Hyper-Text Transfer Protocol
- ❑ ICMP IP Control Message Protocol
- ❑ ID Identifier
- ❑ IP Inter-Network Protocol
- ❑ IPv4 IP Version 4
- ❑ IPv6 IP Version 6
- ❑ ISP Internet Service Provider
- ❑ KISS Keep it simple stupid
- ❑ LAN Local Area Network
- ❑ MAC Media Access Control
- ❑ MS Microsoft
- ❑ MTU Maximum Transmission Unit
- ❑ NAT Network Address Translation
- ❑ PBX Private Branch Exchange

Acronyms (Cont)

- ❑ PHY Physical Layer
- ❑ QoS Quality of Service
- ❑ RED Random Early Drop
- ❑ RFC Request for Comment
- ❑ RIP Routing Information Protocol
- ❑ RTT Round Trip Time
- ❑ SDN Software Defined Networking
- ❑ SMTP Simple Mail Transfer Protocol
- ❑ SSL Secure Socket Layer
- ❑ TCAM Ternary Content Addressable Memory
- ❑ TCP Transmission Control Protocol
- ❑ TLS Transport Level Security
- ❑ ToS Type of Service
- ❑ TTL Time to live
- ❑ UBR Unspecified bit rate
- ❑ UPnP Universal Plug and Play

Acronyms (Cont)

- ❑ VBR Variable bit rate
- ❑ VCI Virtual Circuit Identifiers
- ❑ VLAN Virtual Local Area Network
- ❑ VPN Virtual Private Network
- ❑ WAN Wide Area Network
- ❑ WiFi Wireless Fidelity

Scan This to Download These Slides



Raj Jain

<http://rajjain.com>

http://www.cse.wustl.edu/~jain/cse473-20/i_4nld.htm

Related Modules



CSE 567: The Art of Computer Systems Performance Analysis

https://www.youtube.com/playlist?list=PLjGG94etKypJEKjNAa1n_1X0bWWNyZcof

CSE473S: Introduction to Computer Networks (Fall 2011),

https://www.youtube.com/playlist?list=PLjGG94etKypJWOSPMh8Azcg5e_10TiDw



CSE 570: Recent Advances in Networking (Spring 2013)

<https://www.youtube.com/playlist?list=PLjGG94etKypLHyBN8mOgwJLHD2FFIMGq5>

CSE571S: Network Security (Spring 2011),

<https://www.youtube.com/playlist?list=PLjGG94etKypKvzfVtutHcPFJXumyyg93u>



Video Podcasts of Prof. Raj Jain's Lectures,

<https://www.youtube.com/channel/UCN4-5wzNP9-ruOzQMs-8NUw>