

Computer Networks and the Internet

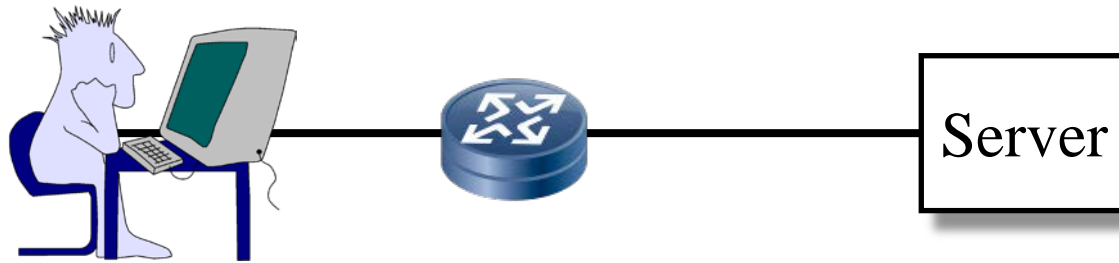

Raj Jain

Washington University in Saint Louis

Saint Louis, MO 63130

Jain@wustl.edu

Audio/Video recordings of this lecture are available on-line at:

<http://www.cse.wustl.edu/~jain/cse473-22/>

Student Questions

- ❑ Can you provide the slides (ppt or pdf) since it's convenient to take notes directly on them?

Yes. All slides are on the course website. URL is on every slide.

Note: Questions discussed during regular Q&A sessions are marked with ❑. New questions asked during Exam 1 review are marked with ❖



1. What is Internet?
2. Switching: Circuit vs. Packet
3. Edge vs. Core
4. Network Performance Measures: Delay, Loss, Throughput
5. Protocol Layers
6. Network Security
7. History

Note: This class lecture is based on Chapter 1 of the textbook (Kurose and Ross) and the slides provided by the authors.

Student Questions

- ❑ Are we required to read the textbook?
Yes. After watching the video. Maybe after the Q&A session when the video is completely understood. You can ask additional questions anytime.
- ❖ Since Chapter 1 is a broad overview, will we be required to know about every layer at a surface level? Or what is the extent of knowledge for chapter 1? It seems like it discusses mainly the physical layer.
Yes, Chapter 1 discusses the topics listed on this slide. You need to know things at this level of detail. For example, you should know what layer 3 (IP) does but you may not know how it does it.

What is a Network?

- ❑ **Network:** Enables data transfer among nodes
 - Generally heterogeneous nodes
 - More than **two** nodes
 - E.g., Your home or office network

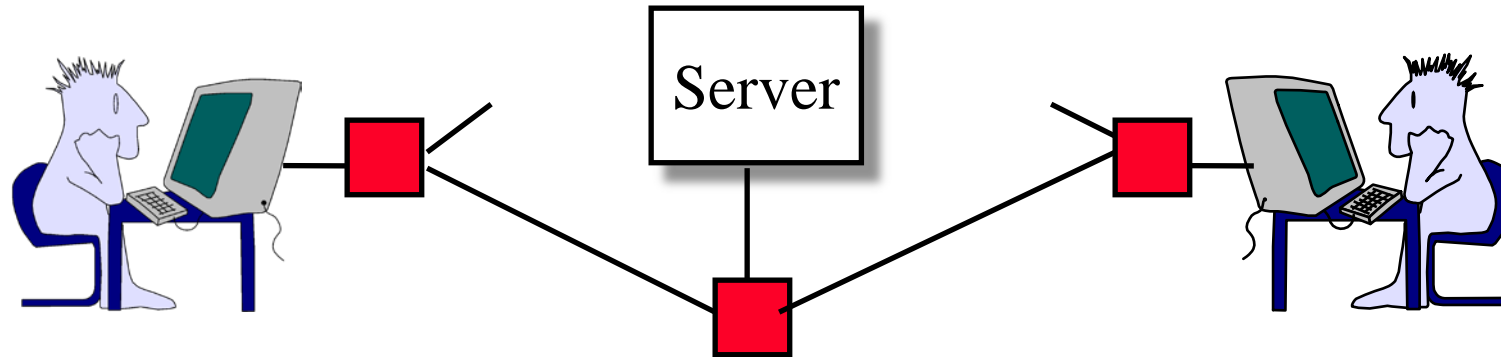

- ❑ **Communication:** Two nodes.
 - Link level electrical issues.



Student Questions

- ❑ Can multiple nodes exist in one physical device? If so, can we treat one physical device with various nodes as a network?

Yes. Yes.

- ❑ What are heterogeneous nodes?

Homogeneous=Similar

Heterogeneous=It may not be similar

- ❑ What are nodes? Is it a point where a connection is established between two points?

A node is any device connected to the network.

Key Concepts



- ❑ **End Systems:** Systems that are sinks or sources of data, e.g., Desktops, Laptops, Servers, Printers, Cell Phones, etc.
- ❑ **Intermediate Systems:** Systems that forward/switch data from one link to another, e.g., routers, switches
- ❑ **Hosts:** End Systems
- ❑ **Gateways:** Routers
- ❑ **Servers:** End Systems that provide service, e.g., print server, storage server, Mail server, etc.
- ❑ **Clients:** End systems that request service
- ❑ **Links:** Connect the systems.
Characterized by transmission rate, propagation delay

Student Questions

- ❑ Could an intermediate system be considered a link?
Link is usually a medium, e.g., wire or radio, or light.
- ❑ Could the service of linking two nodes characterize a system as a server?

Not necessarily. A router is an intermediate system. Even though they are providing the routing service, we don't typically call them servers, particularly since they are invisible.

- ❑ Are there end systems that don't request service? (e.g., non-clients)

Yes, some end systems, e.g., sensors, provide service. Some monitor the network. Etc.

- ❑ So the servers could be called host, and a client could also be called host?

Yes.

- ❑ What specifically do routers do?

Routers forward packets

- ❑ How do we distinguish between intermediates and links?

Systems can store and forward packets. Links simply pass the bits from one end to another, like houses vs. roads.

- ❑ What is the difference between hosts and servers?

Hosts=Nodes

Types of Node: Servers and Clients

What is Internet?

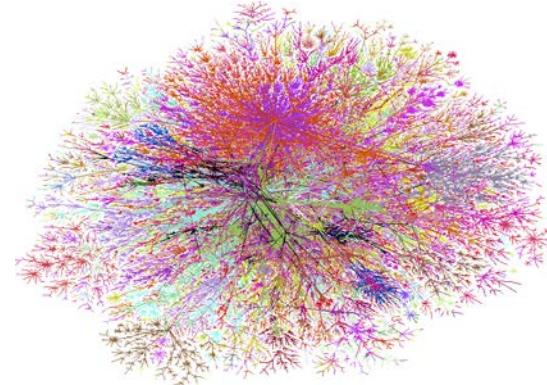
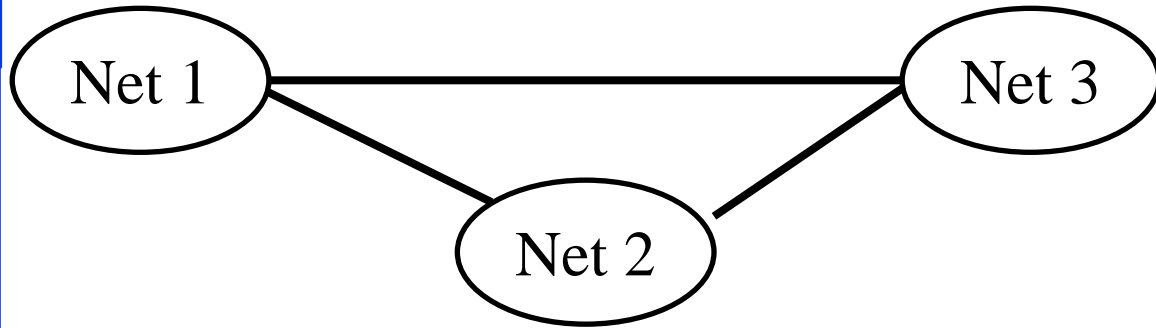

- ❑ Internet = Inter-Network = Network connecting networks
- ❑ Approximately 1.05B hosts on Internet in 2016.
- ❑ ISP: **Internet Service Provider**.
 - Provide access to Internet.
 - Telecommunications (Telephone) Companies, AT&T, Verizon, Comcast, ...
 - Coffee Shops (Wi-Fi)

Student Questions

- ❑ Why are coffee shops considered ISP?
They provide Internet service.
- ❑ What makes phone calls become free?
Internet is basically free.
- ❑ Do ISPs have levels? (Maybe it is the Tier mentioned later in the lecture). For example, if the coffee shops are using AT&T, but I am using Wi-Fi provided by the coffee shops, which is my ISP?
Your ISP is the coffee shop.
- ❑ Since the Internet is, from what I understand, a network of networks, what would the links between each network be in this case, and could it be possible that a network would serve as the link between 2 other networks?
Yes. Two networks can be connected by one link or more than one link (network).

Ref: <http://www.statista.com/statistics/264473/number-of-internet-hosts-in-the-domain-name-system/>

Washington University in St. Louis

<http://www.cse.wustl.edu/~jain/cse473-22/>

©2022 Raj Jain

Types of Networks

Point to point vs. Broadcast

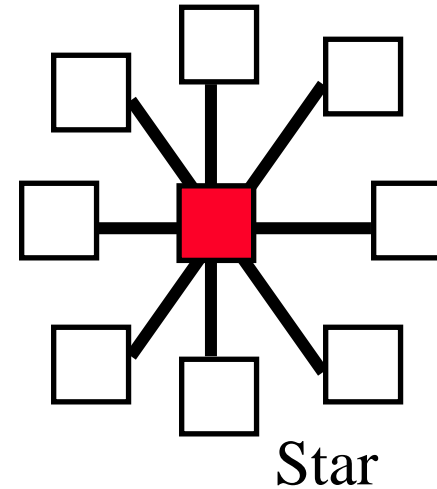
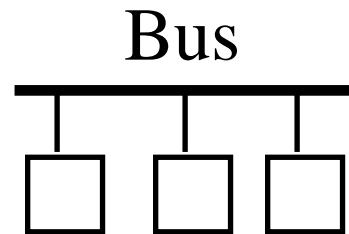
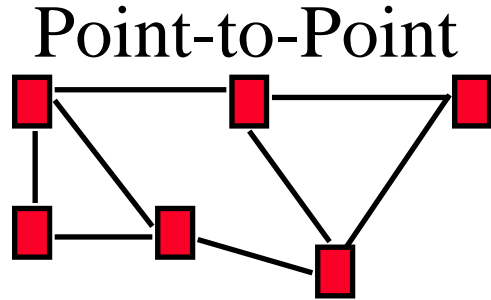

Circuit switched vs. packet switched

Circuit: A path (circuit) is setup before transmission.
All bits follow the same path, e.g., Phone

Packet: Packets of bits are forwarded individually

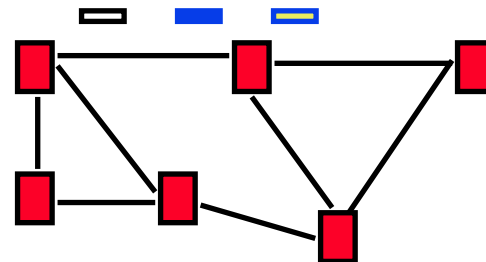
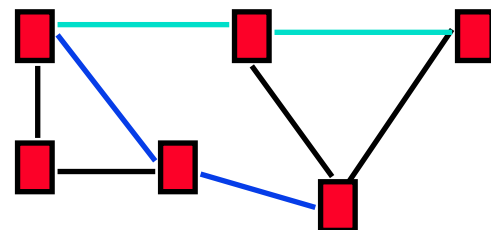

Student Questions

- In what cases, if any, are circuit-switched networks used?
Phone network
- Can wireless connections can only use packet-switching?
Therefore, is circuit-switching not as prevalent?
Wireless can use both circuit and packet switching. Circuit-switched networks exist but are less prevalent.
- Did this mean that a circuit can be bidirectional, and a packet is unidirectional?
Both can be bidirectional or unidirectional.
- Is a circuit (path) always physical?
No. There are virtual circuits.
- How does the packet know the address of where to go if the connection has not been set up beforehand, like the circuit?
The address is put on the packet by the sender.
- What would an example of a star network-type be?
Your home Ethernet or Wi-Fi.
- Is it possible to combine the types of networks? For example, use a star network as the base where each node that extends from the center is a bus network itself.
Yes.
- Do each 2 nodes have a link in Point-to-Point networks?
Each node should have at least one link. Every pair of nodes may not have a direct link.
- Would a point-to-point network be inefficient in the sense that it requires every node to be connected to every other node, effectively creating/maintaining a very large number of connections per node?
Point-to-point does not require "full mesh."
- What happens when more than one node broadcasts a message on the bus network? Is there a clash if they are going in opposite directions? How is it resolved?
Yes. There are collisions. There are protocols to take care of it.



Multiplexing

- ❑ How multiple users can share a link?
- ❑ **Time Division Multiplexing (TDM)**

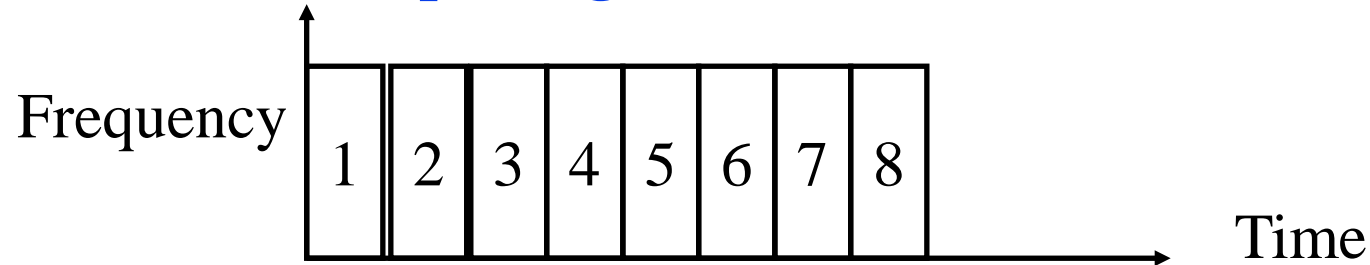

- ❑ **Frequency Division Multiplexing (FDM)**

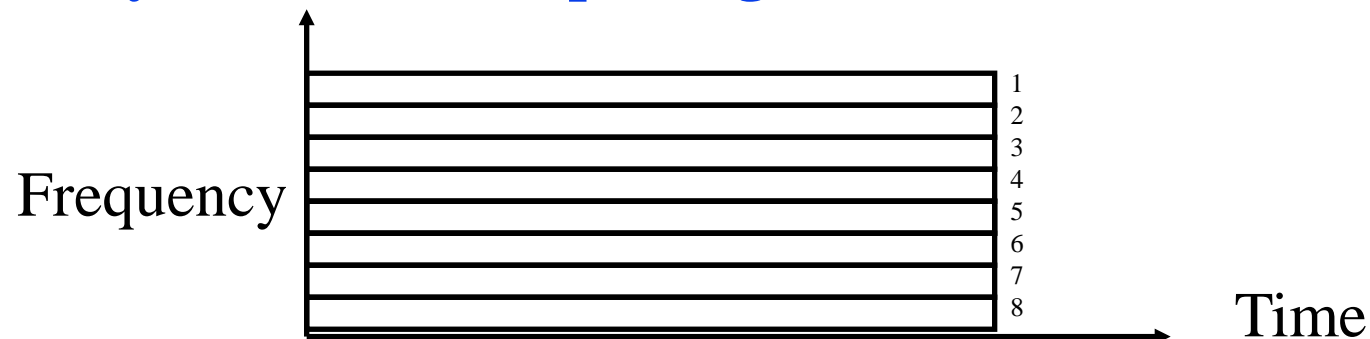

- ❑ Other multiplexing methods will be covered as needed.

Student Questions

- ❑ Which multiplexing methods are more popular nowadays?
Both. Plus a few others.
- ❑ Is FDM more efficient compared to TDM since if we have a lot of clients and we use TDM, the delay a client receives grows linearly with the number of clients?
No. There are many considerations-- Scalability, burstiness of usage, etc.
- ❑ Did dial-up networks not use multiplexing? (Since you could not use the internet and phone at the same time).
They multiplexed many users on the same trunk line.
- ❑ Is multiplexing only used in the circuit-switched?
TDM is also multiplexing.
- ❑ Why would one multiplexing method (TDM/FDM) be preferable/used over the other?
Scalability, efficiency,
- ❑ In a circuit-switched network, does information still need to be divided into multiple packets?
It is not necessary, but you can.
- ❑ Are there limitations to what style of multiplexing one can use based on the type of network associated?
Yes. But you can virtualize and provide any type of service over any time of the network.
- ❑ Is there a mixed pattern of TDM and FDM?
Yes.

Types of Networks (Cont)

- ❑ **Local Area Networks (LAN):** 0-2 km, Single Ownership
- Metropolitan Area Networks (MAN)** 2-50 km,
- Wide Area Networks (WAN)** 50+ km
 - Originally LAN/MAN/WAN technologies were different
 - Now they are all same
- ❑ **Telecom Networks:**
 - **Access:** Between subscriber and the service provider
 - **Metro:** Covering a city
 - **Core:** Between cities

Student Questions

- ❑ Was ethernet TDM because it is a bus network? Is it still TDM even though it is used in star networks?

Yes. Ethernet is still TDM.

- ❑ Is multiplexing used to handle the problem that several connections share the same link? How can we guarantee connections not to interfere each other? Is multiplexing only happening in circuit switched?

No TDM is multiplexing. Proper resource allocation can prevent interference.

- ❑ What is the disadvantage of FDM?

Allocated but not used can be wasted.

- ❑ Is using TDMA somewhat like TDM?

TDMA=TDM Access

- ❑ Why did LAN, MAN and WAN have become the same?

We could design technologies that work at all distances.

- ❑ Why are the telecom networks between cities called cores?

Terminology.

- ❑ Is MAN still in use these days?

Yes. 4G, 5G are MAN.

Structure of the Internet

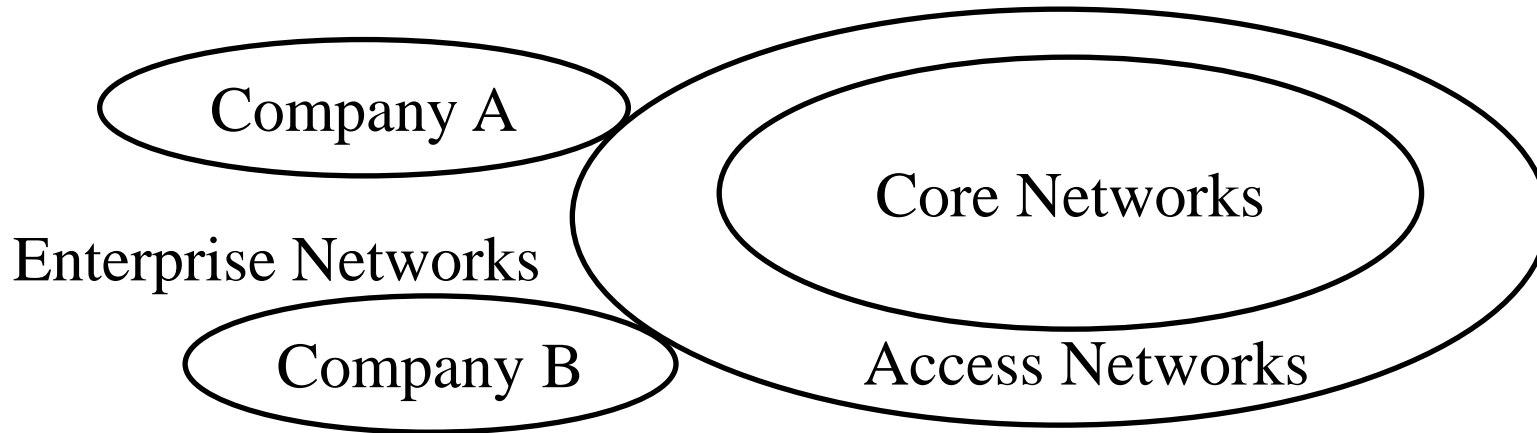

- ❑ Enterprise/Home Networks: **Stub** Networks.
Privately owned ⇒ Not owned by ISP
e.g., WUSTL network: Ethernet and WiFi
- ❑ **Access** Network: Enterprise/Users to ISP (in the city)
WiFi, 3G/4G, DSL
- ❑ **Core** Network: ISP's network (between city): Optical Fiber

Student Questions

- ❑ Why this diagram depicts core networks as a subset of access networks?
This is not a Venn diagram.
- ❑ Why the access networks circle is bigger than core networks.
Access is on the edges of the core. Access connects to customers and is every where.
The airplanes owned by FedEx/ Amazon/UPS are their core transports.

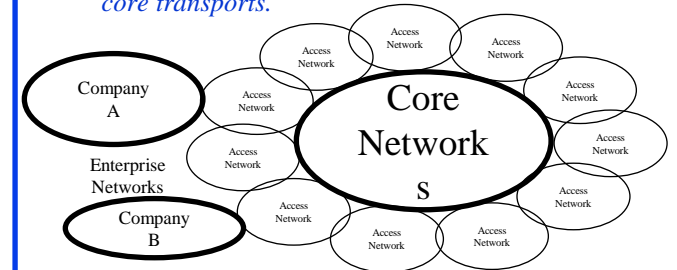

More questions at the end.

- ❑ What are stub networks?
They don't allow other company's packets to go through.
- ❑ Does Core Network mean only between networks of one ISP?
No. A core can connect multiple ISPs.

Structure of the Internet

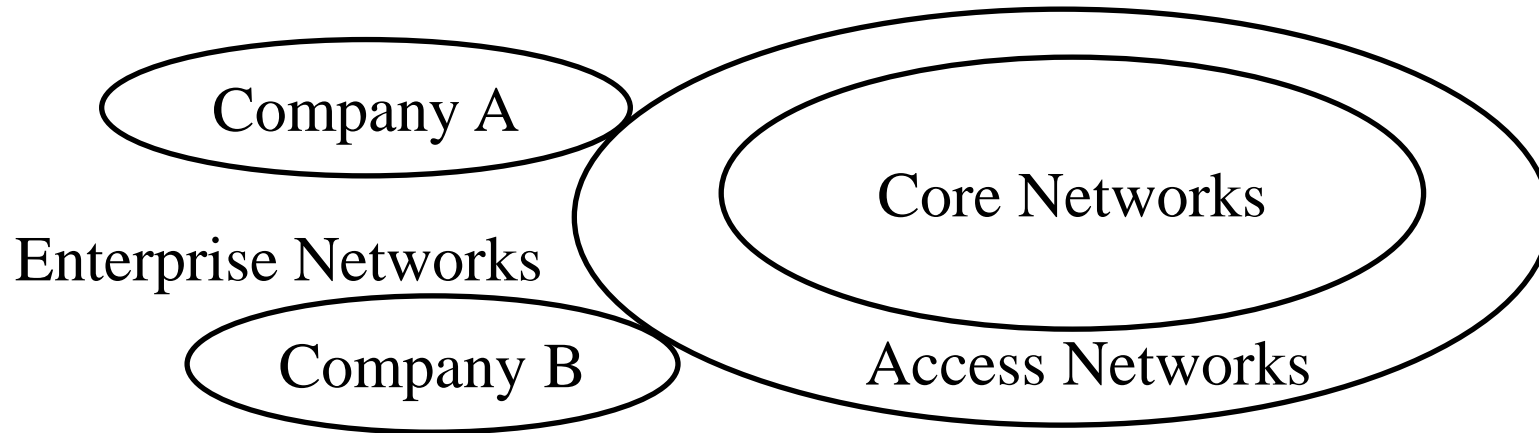

- ❑ Enterprise/Home Networks: **Stub** Networks.
Privately owned ⇒ Not owned by ISP
e.g., WUSTL network: Ethernet and WiFi
- ❑ **Access** Network: Enterprise/Users to ISP (in the city)
WiFi, 3G/4G, DSL
- ❑ **Core** Network: ISP's network (between city): Optical Fiber

Student Questions

- ❖ Since stub networks are not owned by ISP, how do they provide Internet? As I remember, ISP provides Internet. Does this mean stub networks are ISP themselves?

No. Stub networks are clients. They do not provide Internet to anyone outside. For example, WUSTL is a stub network.

Types of ISPs

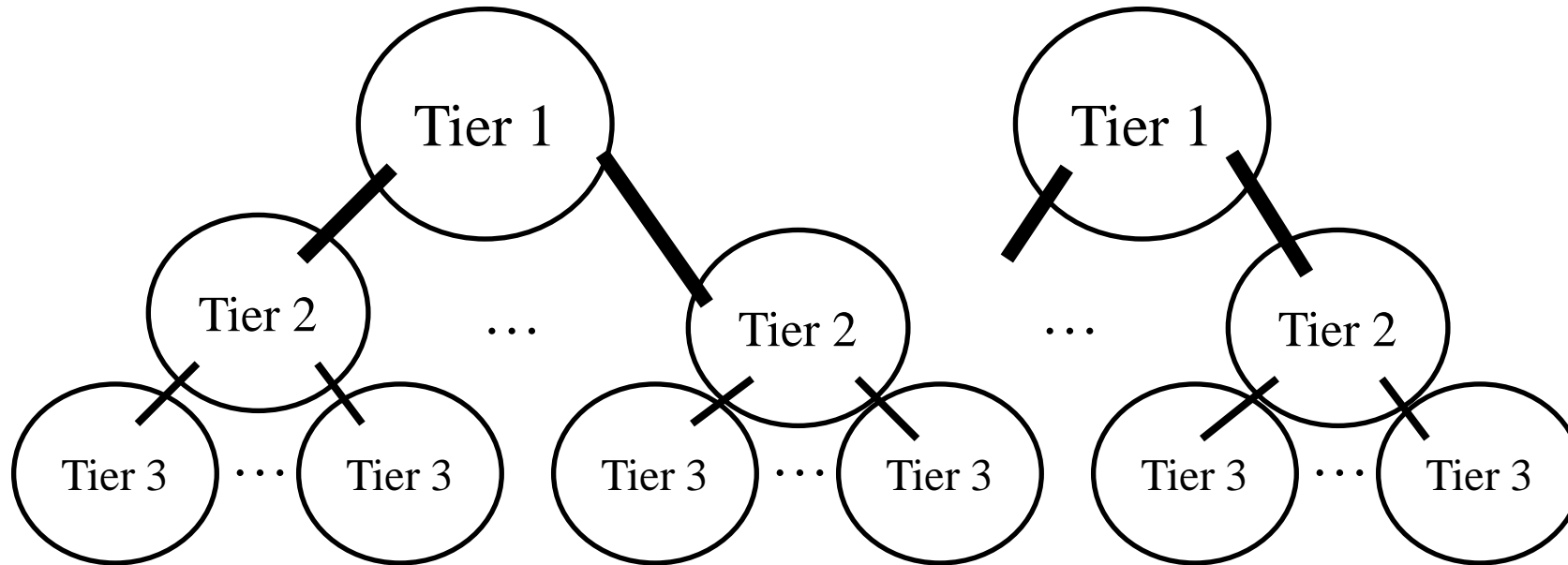

- ❑ **Tier 1:** Global or National, e.g., AT&T, Verizon, ...
- ❑ **Tier 2:** Regional
- ❑ **Tier 3:** Local

Student Questions

- ❑ At what level/tier are tier 1 ISPs usually connected to each other?
There are no higher Tier ISPs. A Tier 1 network might be connected to another Tier 1 network through a third Tier 1 network.
- ❑ Would you elaborate on practical differences between coaxial vs twisted pair (for example relative transmission rates), and on practical differences between wireless vs microwave?
 - ❑ Is all wireless microwave?
No. Please wait till Module 7.
 - ❑ Is the main upside to unguided transmission media the ability to have the end system to be more mobile?
Some times wireless is used between towers to reduce cabling cost.
- ❑ When you refer to just "fiber", are you referencing optic fiber?
Yes
- ❑ Who decides which ISP belongs to what tier?
Higher tiers provide services to lower tier.
- ❑ Could Tier 2 or 3 use the infrastructure of Tier 1's network?
Yes.
- ❑ Do Tier 1 ISPs always cover regions that Tier 2/3 ISPs cover?
Not necessary.
- ❑ Is the connection between Tier 1 and Tier 2 or the connection between Tier2 and Tier3 core networks?
Both

Transmission Media

□ Guided:

- Twisted Pair
- Coaxial cable
- Optical fiber

□ Unguided:

- Microwave
- Satellite
- Wireless

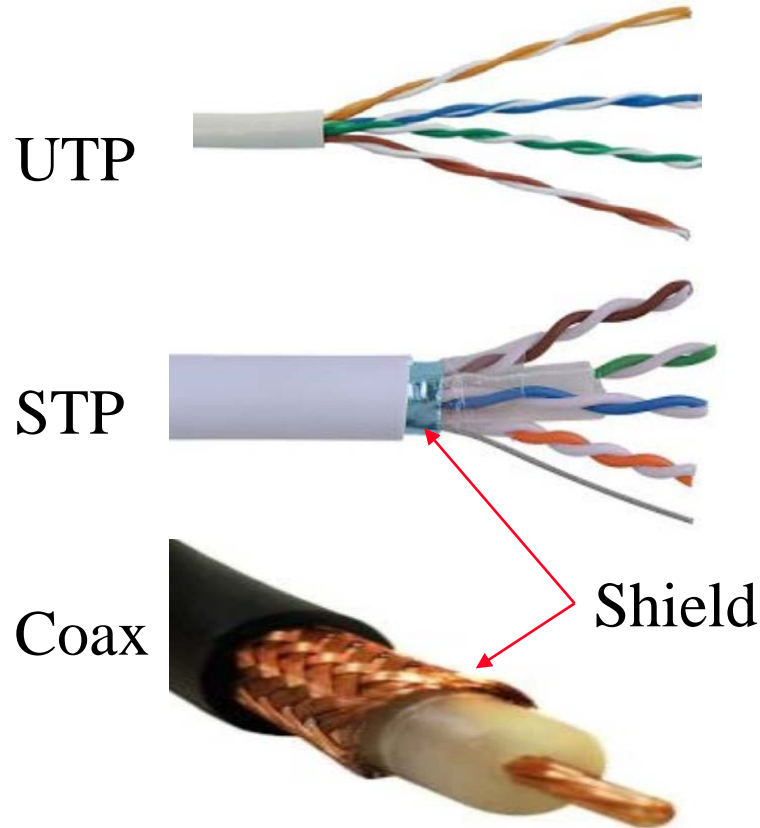

Student Questions

- It was mentioned in lecture that a Coaxial cable is an example of an STP (Shielded Twisted Pair). Googling the difference seems to indicate that "Twisted Pair Cables" are distinct from "Coaxial Cables". Can you clarify the relationship between Twisted Pair vs Coaxial?

Coaxial cable is shielded but not twisted because it has only one wire. STP has many pairs and each pair is twisted. A metallic shield protects all pairs.

- Is a microwave how all wireless connections are made?

Most.

- Is there such a thing as an unguided wired transmission medium?

Antenna

- What is a coaxial cable?

Cable from the cable company

- Can a communication bus be either guided or unguided?

Busses are usually guided.

- Are there any strong advantages of using guided over unguided and vice versa?

Yes. Security.

- Why can't we know where signals go in unguided media? Does it have to do with frequency?

We know. We can sense it..

Twisted Pair (TP)

- Separately insulated
- Twisted together
- Often "bundled" into cables
- Usually installed in building during construction



(a) Twisted pair

- ❑ Twists decrease the cross-talk
- ❑ Neighboring pairs have different twist length
- ❑ Most of telephone and network wiring in homes and offices is TP.

Student Questions

- ❑ What is the mechanism behind twisted pair can reducing cross-talk? why neighboring pairs need to have different twist length? Did there exists a limit speed of twisted pair?

Part of Electrical Engineering Communications course.

- ❑ Why do twisted pairs help to reduce interference?

Canceling the electromagnetic interference.

- ❑ Would two untwisted wires running parallel interfere with each other? Also, would wire pairs twisted at the same twist length interfere with each other?

Yes. Yes. More similarity=> More interference.

- ❑ In a twisted pair, is one the main channel and the other just serves as shielding or are both interpreted at the destination?

Both.

- ❑ What is the relationship between Tier and an ISP Network?

Tier is a class of ISPs.

Shielded and Unshielded TP

❑ Shielded Twisted Pair (STP)

- Metal braid or sheathing that reduces i
- More expensive
- Harder to handle (thick, heavy)
- Used in token rings

❑ Unshielded Twisted Pair (UTP)

- Ordinary telephone wire
- Cheap, Flexible
 - ⇒ Easiest to install
- No shielding
 - ⇒ Suffers from external interference
- Used in Telephone and Ethernet

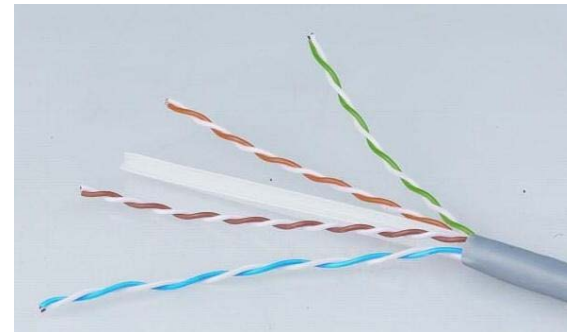

Student Questions

- ❑ How specifically are infrared light used to input in optical cables?

Lasers are used to inject light in to a hair-thin optical fiber.

- ❑ What are token rings?

Competed with but obsolete by Ethernet.

- ❑ Are UTPs links? If so, does UTP use FDM or TDM?

You can use either one.

- ❑ Is twisted length is the standard to differentiate those categories?

One of many parameters.

- ❑ Are there Cat 1 and Cat 2?

No longer.

- ❑ How to distinguish between a telephone wire and an Ethernet wire?

Telephone=2 or 4 wires

Ethernet=8 wires

- ❑ Since Ethernet uses UTP, and the telephones use UTP too, can we use the telephone wire as an Ethernet cable?

No. You can use an Ethernet cable as a phone wire but not the other way around. Ethernet requires higher performance.

UTP Categories

❑ Cat 3

- Up to 16MHz
- Voice grade found in most offices
- Twist length of 7.5 cm to 10 cm

❑ Cat 4

- Up to 20 MHz. Not used much in practice.

❑ Cat 5

- Up to 100MHz
- Used in 10 Mbps and 100 Mbps Ethernet
- Twist length 0.6 cm to 0.85 cm

- ❑ Cat 5E (Enhanced to 100 MHz),
Cat 6 (250 MHz), Cat 6A (500 MHz),
Cat 7 (700 MHz), CAT 7A (1000 MHz)
Cat8 (2000 MHz), ...

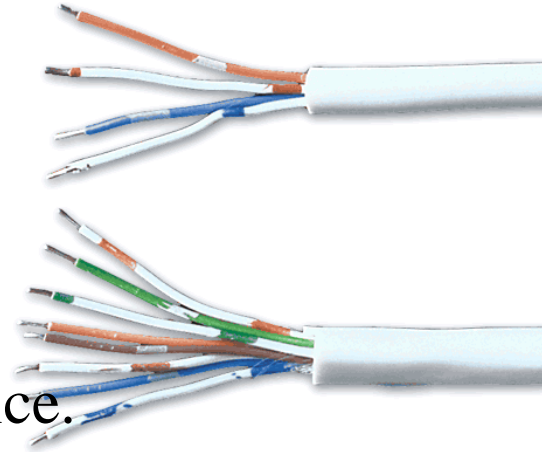

Student Questions

- ❑ What is the number behind the Cat (Category) related to the frequency it can hold?

Class or quality.

- ❑ When you say broadcast if we transmit too much data over the wire, do you mean that it will be leaked out and can be picked up by a 3rd party?

Broadcast=Everyone can hear it.

- ❑ Why shorter twisted length corresponds to a higher transmission rate?

Taught in ECE Communications courses.

- ❑ Is our network speed bound by the slowest transmission media? If so, how can we detect the bottlenecks at our end?

There are many ways to find the bottleneck.

- ❑ Do different amounts of Hz of different UTP categories mean their ability to send those kinds of signals? Like from 10 MHz up to 100 MHz? And why more MHz means better UTP.

More MHz = More bits/second

Optical Fiber

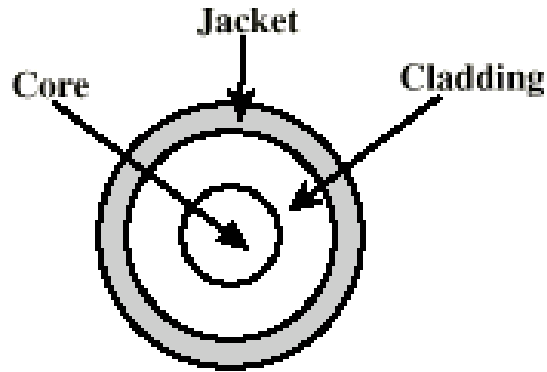

- Glass or plastic core
- Laser or light emitting diode
- Specially designed jacket
- Small size and weight

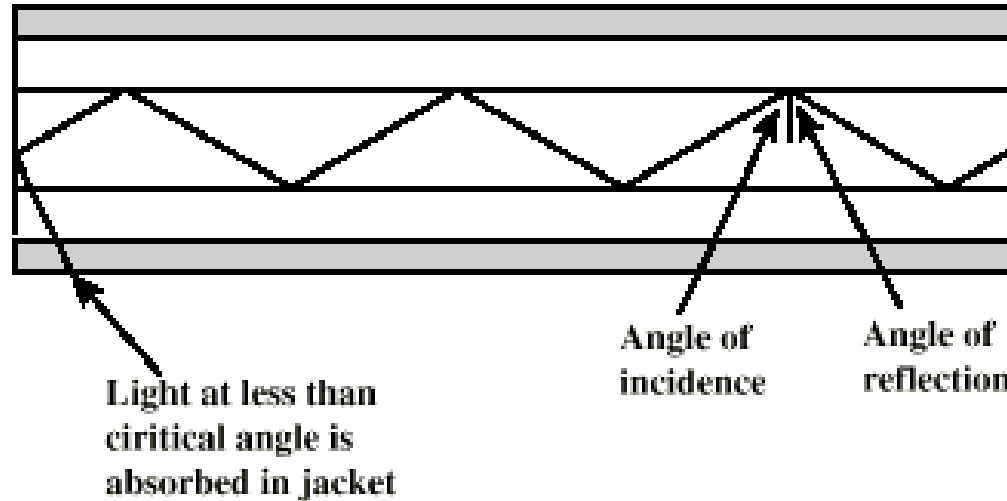

- ❑ A cylindrical mirror is formed by the cladding
- ❑ The light wave propagate by continuous reflection in the fiber
- ❑ Not affected by external interference \Rightarrow low bit error rate
- ❑ Fiber is used in all long-haul or high-speed communication
- ❑ Infrared light is used in communication

Student Questions

- ❑ Is infrared considered a to be a subset of microwaves?
These are different frequencies. See Slide 18.
- ❑ How much do we need to know about the spectrum? (like what range is radio)
Yes.
- ❑ Is it possible to use ultraviolet light or visible light for optical communication as both of them have a shorter wavelength and thus seem to have a higher possible transmission rate?
Yes. Properties of the signal are different and so cost and applications are different.
- ❑ How is it possible for light at less than critical angles to be absorbed in a jacket?
Light can become heat.
- ❑ How is the optical fiber cable able to send light signals even when the cable is bent? Wouldn't the bending of the cable distort the path of the light?
No bends are like a mile wide turns for nano-nano-meter waves.
- ❑ Is cost the only benefit of copper over optical?
Also, tools to connect copper are simpler.

Optical Communication...History

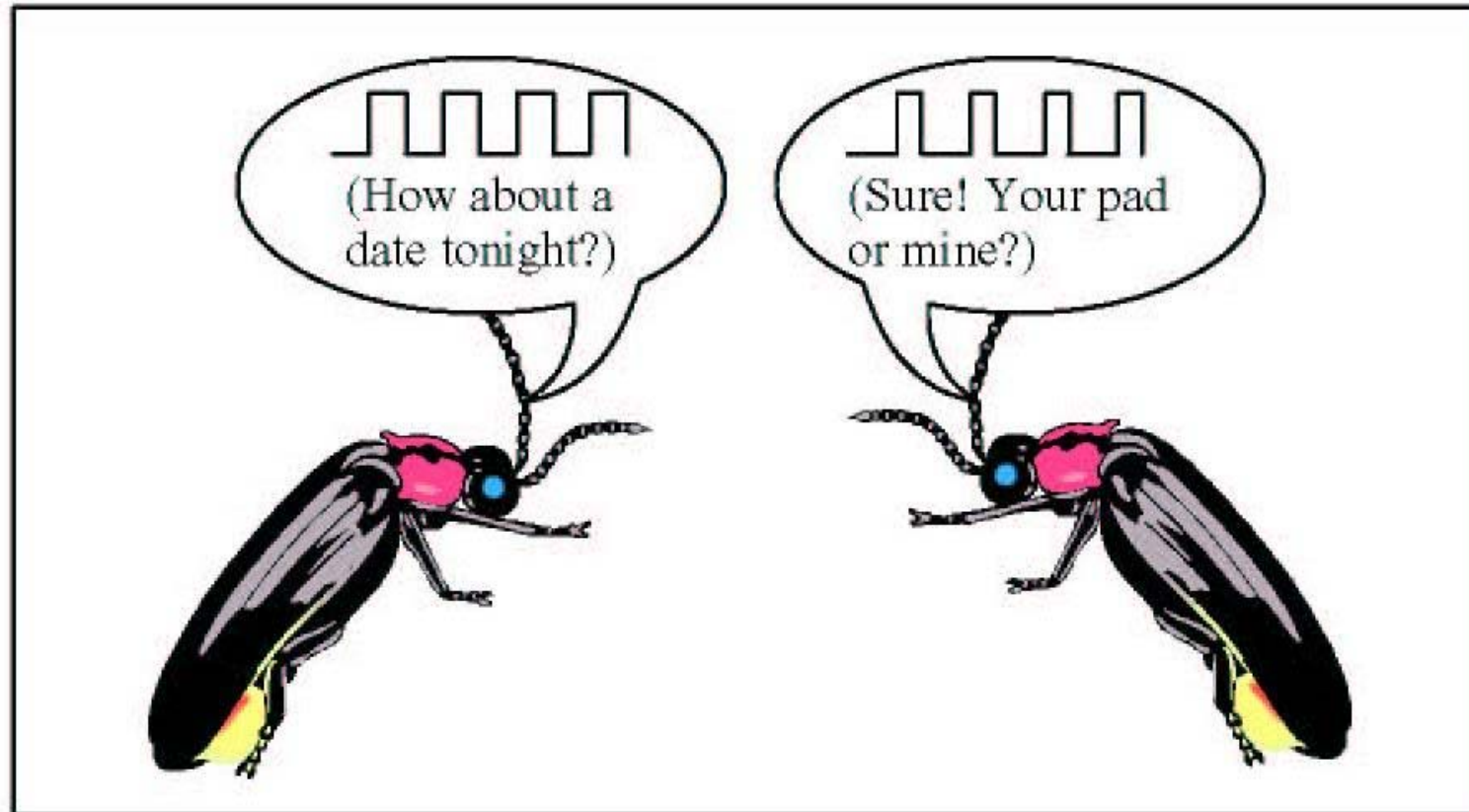

Fireflies use pulse-width modulation.

Student Questions

- Do we get the idea of optical communication from fireflies?

No.

- Is this what happens in the optical fiber?

Yes.

- Why do we transmit a signal? What other ways can we do the same thing today?

*Signal=Communication
Oral, electrical, visual, ...*

Electromagnetic Spectrum

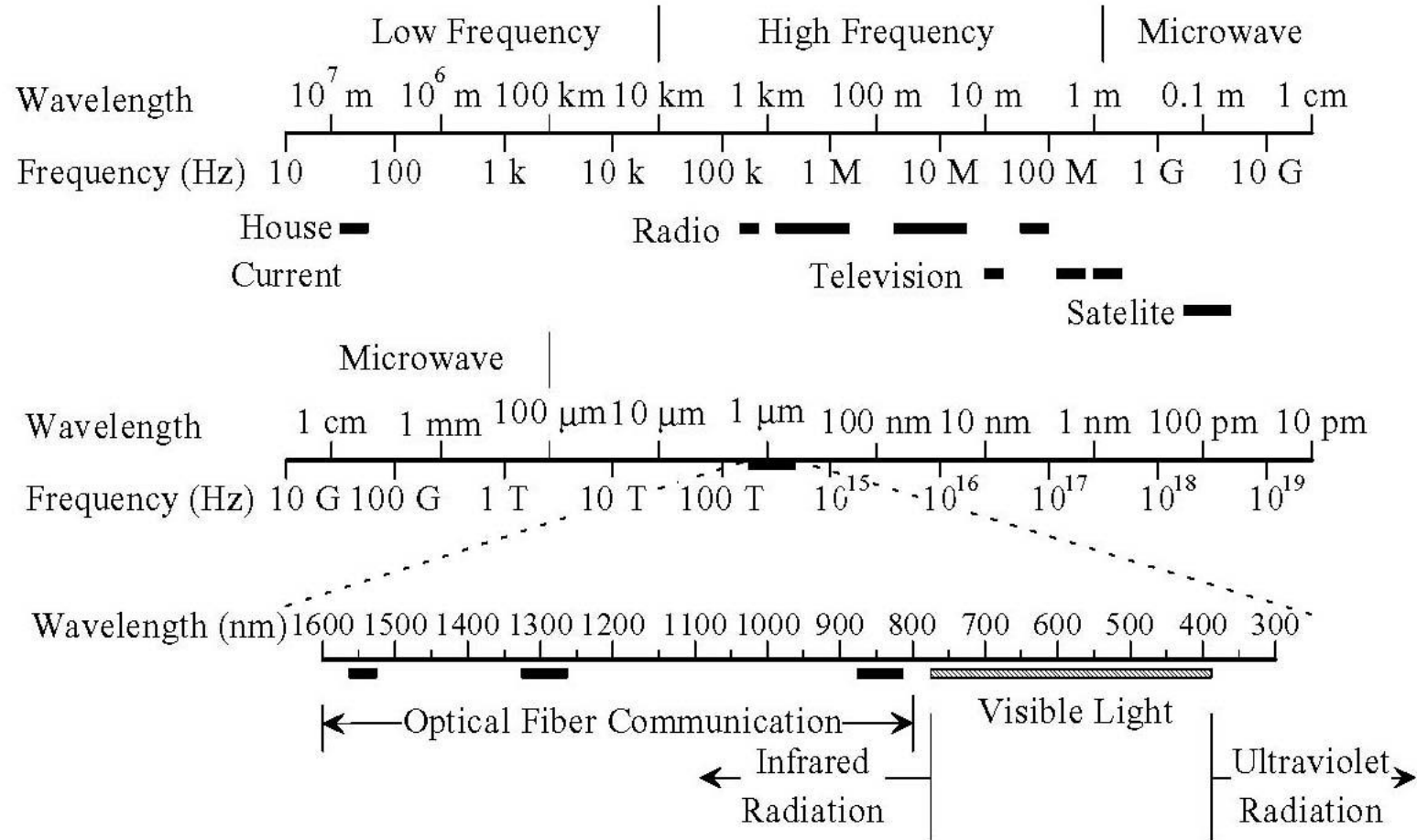

- Infrared light is used for optical communication

Student Questions

- Why can't we use higher or lower frequency for optical fiber communication?
- Lower frequencies are all used up.*
- Why do we use infrared light for optical communication and not something else (e.g., ultraviolet)?
- Part of the advanced networking course.*
- How do we interpret the wavelength or frequency as data we can actually understand?
- Coding. Like Morse code.*
- Would there be an advantage to using wavelengths of light with higher frequencies in an optical connection?
- Both advantages and disadvantages.*
- So technically, I can receive a TV signal by radio which can receive a higher frequency, right?
- Yes. TV is a radio too.*
- Does this mean that we can potentially communicate with the wave the same as a microwave oven?
- We do it every day. Wi-Fi is a microwave.*

Electromagnetic Spectrum

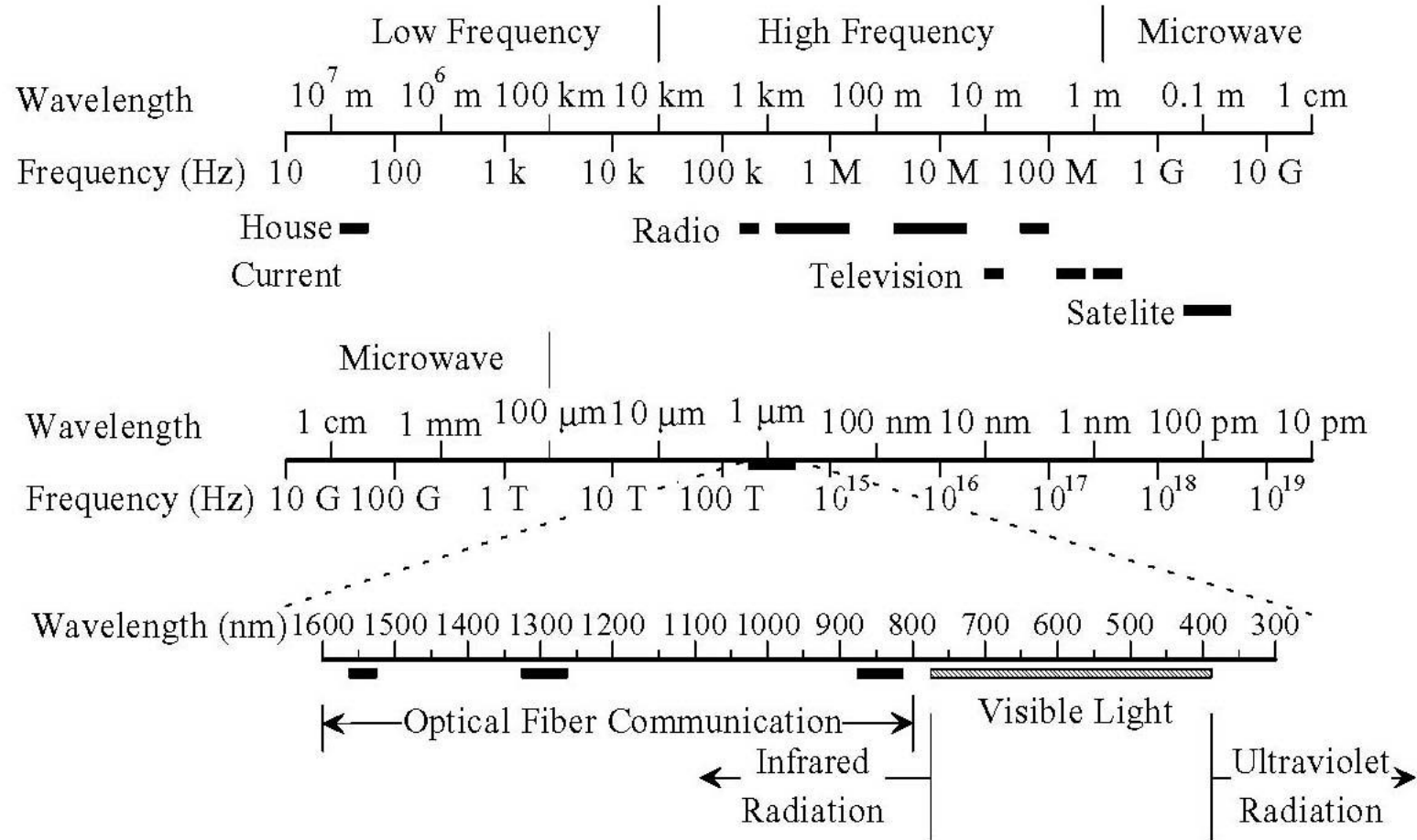

Infrared light is used for optical communication

Student Questions

- ❖ What should we be able to identify on the electromagnetic spectrum?

Basic relationships between various components. Not the fine prints of the numbers.

- ❖ What is the value of the Electromagnetic Spectrum figure? Is it to just show the wavelengths of Optical Fiber Communication?

To understand that sound, electricity, radio, microwave, and light, x-rays are similar.

- ❖ What are the black bars in the figure?

Each black bar has a associated application.

Homework 1A: Networking Media

- [6 points] Which networking media will you use for the following applications and why?
 1. Very large file transfer at home
 2. High-speed multiple channel video transmission at office
 3. News reading while traveling in a car

Note: Do not write the name of the protocol.
Write the name of the media and justify.

Student Questions

- Do we need to do this homework or this is just for some previous semester.

While video is from previous live class. The slides have been updated for this semester. So, yes, you need to do the homework and submit it on the Monday following the class discussion.

-
- Are homework 1A and 1B both due next Monday? (Jan. 24th)

Yes.

- By plain text files do you mean txt files?

Yes.

- So we need a paragraph for each question?

Yes.

Network Edge: Enterprise Networks

1. Ethernet
2. Wi-Fi

Student Questions

- ❑ What is a Network Edge?

Opposite of Network core.

Ethernet



- ❑ Uses UTP (Unshielded Twisted Pair)
- ❑ 10 Mbps, 100 Mbps, 1 Gbps, 10 Gbps
- ❑ Originally bus, now point-to-point (Star) topology

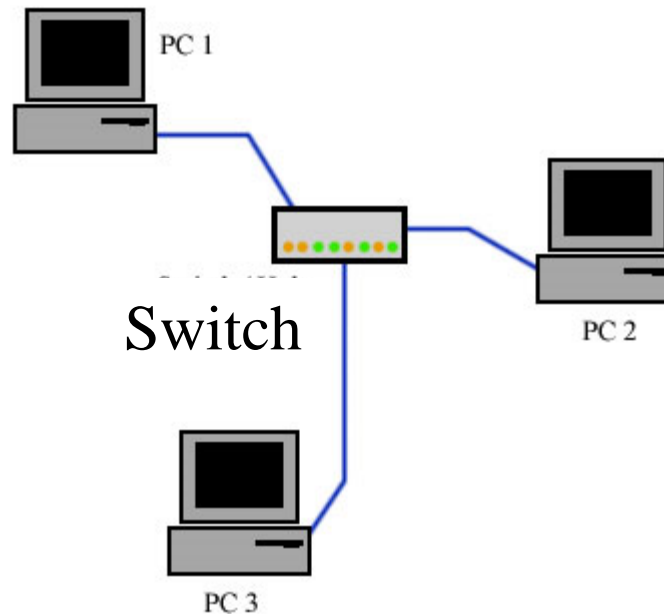
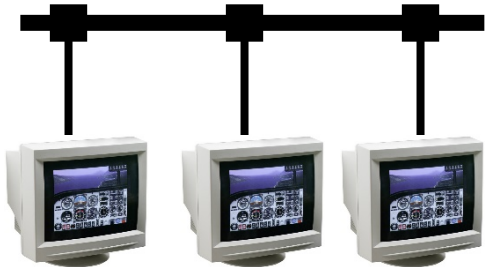

Student Questions

- ❑ Was it the bus or star topology that was more robust against single connection faults?

Bus is susceptible to single cable faults.

- ❑ Was it difficult to transit from bus to star topology?

No. Both existed at the same time.

- ❑ If one client fails in a bus, is the whole chain broken?

Maybe. Maybe not.

Wi-Fi

- ❑ IEEE 802.11
(Institution of Electrical and Electronic Engineers)
- ❑ Uses 2.4 GHz and 5.8 GHz



Student Questions

- ❑ Wi-Fi usually has a router and modem, is a modem a host and a router an intermediate system?

Modem, too, is an intermediate system.

- ❑ Can we not follow the IEEE guidelines?

We do.

- ❑ Can you elaborate on how 2.4 GHz "ran out" and so we need to expand to 5.8 GHz?

Too many nodes broadcasting on the same frequency overloaded 2.4 GHz.

- ❑ Are 2.4 and 5.8 also called 2G and 5G? If the frequency is fixed, why in real life is the speed still changing or fluctuating?

No. 2G and 5G are different generations. Covered in Wireless chapter.

Access Networks

1. DSL (Digital Subscriber Line)
2. Cable
3. Fiber-To-The-Home
4. Wi-Fi
5. LTE (Long Term Evolution)

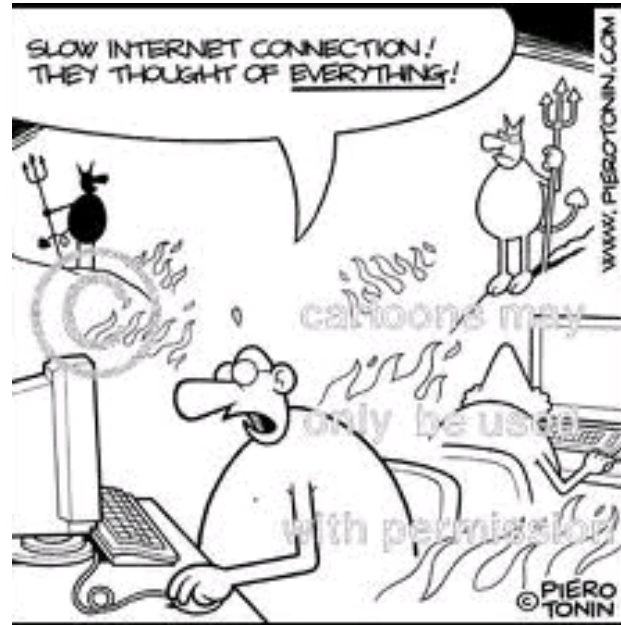

Student Questions

- How is LTE different from 4G?
This is discussed in Module 7. LTE is 3.9G or pre-4G.
- What is LTE/ what does Long Term Evolution mean?
Please wait till Module 7.
- Does Fiber to the Home mean Optical fiber?
Yes.

- What exactly is Fiber-To-The-Home?

AT&T Fiber and Verizon Fiber are FTTH services.

- What exactly does "Long Term Evolution" mean?

"In the distant future"

- Can you explain how dial-up Internet worked? How, if at all, does it relate to DSL?

Too detailed for now.

- Was fiber to the homeless common only because of cost, or were there other factors as well?

Cost.

DSL

- ❑ **Digital Subscriber Line (DSL)**
- ❑ Can transmit very high data rates on phone wire using special equipment at the phone company allowing higher frequency signals

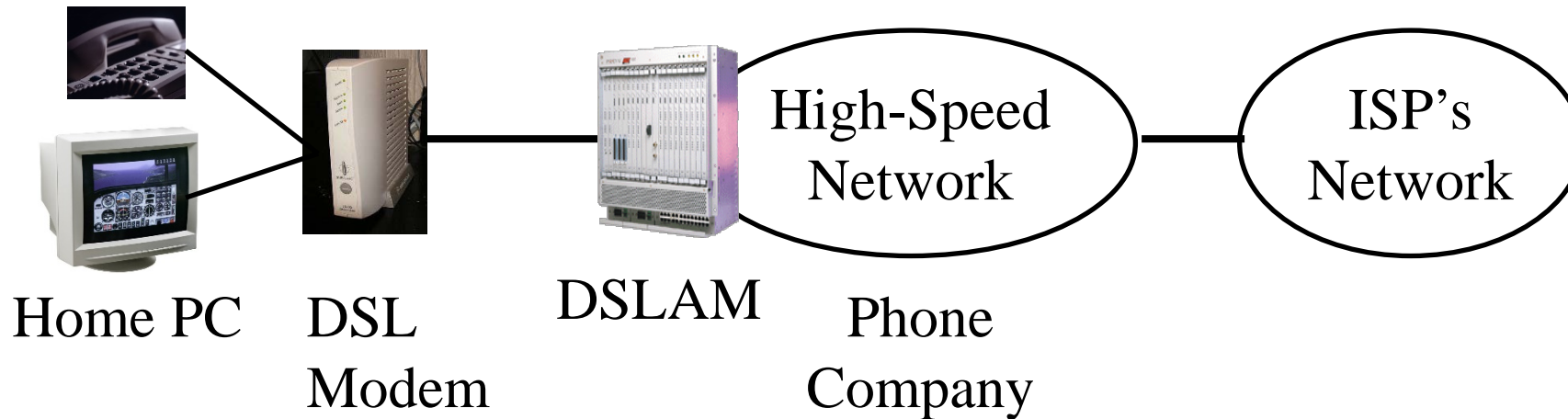

- ❑ DSL Access Multiplexer (**DSLAM**)
- ❑ 100 kbps - 100 Mbps

Student Questions

- ❑ The video had 24 slides (whereas this form only lists 23)
Our mistake.
- ❑ Part 2 link reported "The requested URL /~jain/cse473-21/ftp/i_1cni/i_1cni2.html was not found on this server."
Part 2 was not required till now. It was under preparation when you clicked. It is there now.
- ❑ You mentioned there is a homework 1 on canvas. I am having some problem finding it.
Homework 1A is on these slides. Since it is due only after the class discussion, it was not published on Canvas. It is there now.
- ❑ Where do we turn in our in class assignment?
Unless indicated otherwise, all homeworks should be submitted on Canvas.

- ❑ What kind of wire is a phone wire?
The wire used to connect to your home phone.
- ❑ Is DSL the same thing as Dial-Up?
DSL is a data service using the same wires that were used for phones.
- ❑ Is DSL similar to a phone line?
- ❑ What is a multiplexer?
Combines many circuits



Cable

- ❑ Cable companies have a very-high speed medium (for video transmission)
- ❑ Phone wire = 4kHz for voice
Video Cable = 500 MHz for video
One TV Channel = 6 MHz
- ❑ 100 Mbps down/10 Mbps up
- ❑ Fiber in the main line + Coax in tributaries
⇒ Hybrid Fiber Coax (HFC)



Cable
Modem

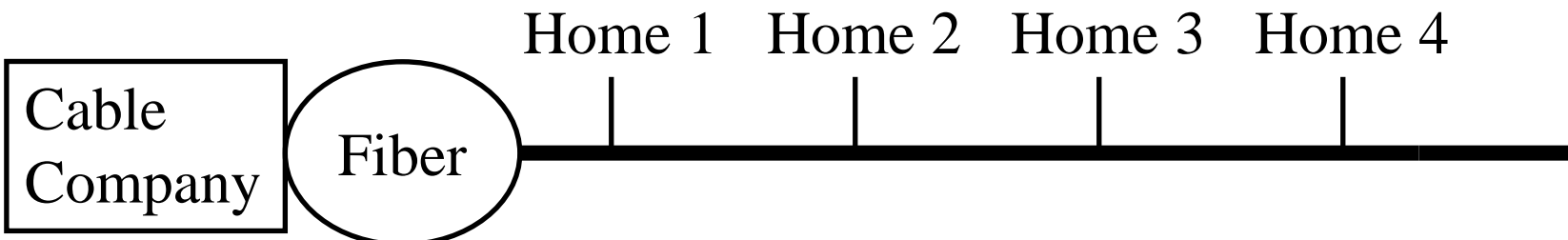

Student Questions

- ❑ Why is the upload speed always slower than the download speed?
Not always. On point-to-point fiber, upload = download.
- ❑ Is it the only difference in structure between DSL and cable that DSL uses UTP while cable uses coaxial wire?
No there are many other differences. Not just media but also protocols.

- ❑ Will using a longer Ethernet cable slow down the connection speed?

It depends upon the type of Ethernet. Older Ethernet -yes. Current Ethernet -no.

- ❑ What is the benefit of HFC?
Combines copper and fiber to reduce cost

Fiber-To-The-Home (FTTH)

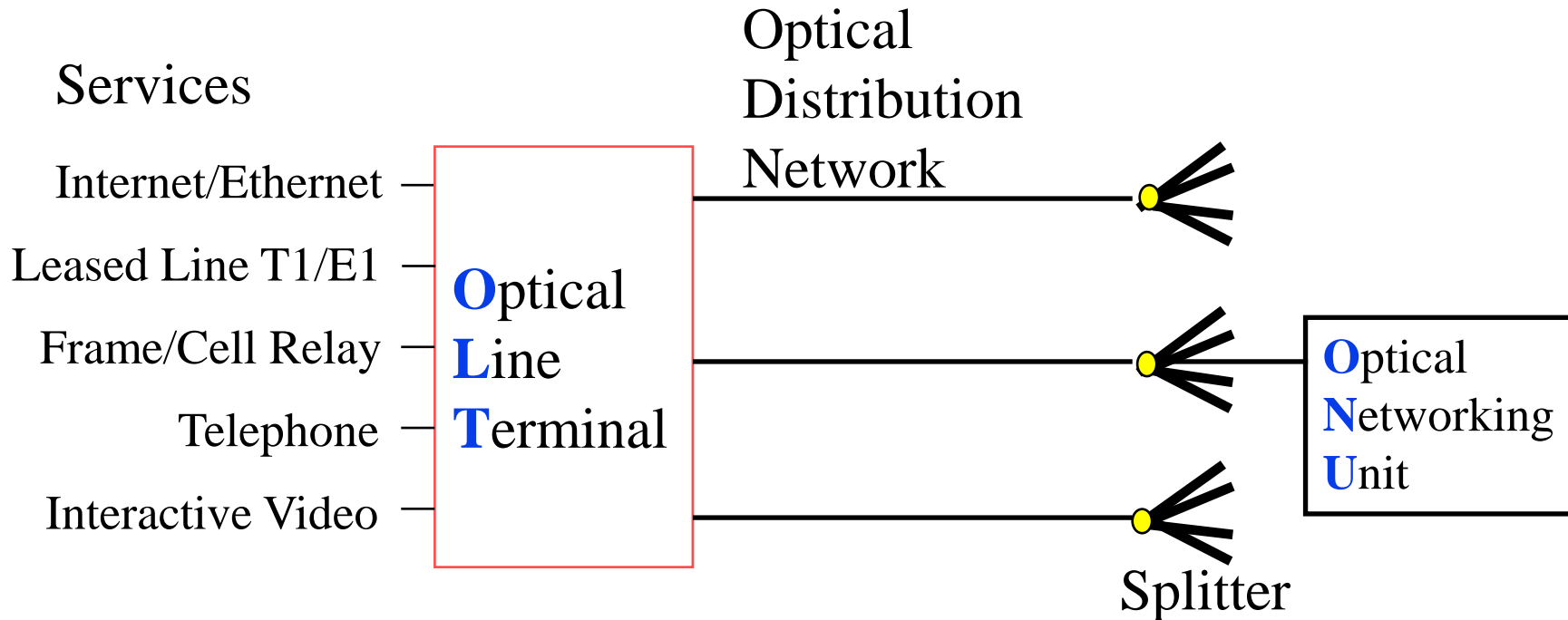

- 1+ Gbps per home. Multiple services.
- No electronic components in the distribution system
⇒ Passive ⇒ Reliable
- Passive Optical Network (PON)

Student Questions

- What is the difference between analog and digitalized DSL?

Analog signal



Digital signal



- How frequently is FTTH used in the US compared to cable?

AT&T Fiber just came to St. Louis.

- Is FTTH more reliable than cable?

Not necessarily.

- Do DSL and cable also use a passive splitter as FTTH does? If not, then how do they distribute the packets?

DSL has switches and routers to distribute to packets. These are not passive. Cable can use switches or hubs. Hubs can be passive but are not generally used.

- Is OLT at home and ONU at the source?

OLT at phone co. ONU at home.

- Are cable and Fiber-to-the-Home both installed at the same location in a neighborhood, for instance?

There may not be any cable unless it is HFC.

- If we a fiber split into 5 and go to 5 different users. Then before the split, all the data for 5 people are combined together, is that correct?

Each home has its own key and can only decrypt only its traffic.

Wireless Access Networks

- ❑ Wi-Fi hot spots
- ❑ Cellular access: 2G/3G/4G (LTE)

Student Questions

- ❑ Can you explain what LTE is as well as 2G and 3G? Where on the EM Spectrum does LTE fall?
1G/2G/3G/4G/5G are all wireless telecom technologies. We will cover them briefly in Chapter 7. LTE is 3.9G or pre-4G. All of these currently use 700 MHz-5GHz spectrum. The spectrum has to be purchased in Government Auctions.

- ❑ What counts as active components? Can you give an example?

Power makes a component active.

- ❑ You mentioned that OLT and ONU are active. Does that mean that if a user wants to quit, then the company can prevent him from stealing the network by ONU? Since the company won't uninstall the fibers from their home, right?

OLT drops all packets from sources who have not paid.

Network Performance Measures

- Delay
- Throughput
- Loss Rate

Student Questions

- Which of the Network Performance Measures are most used/valuable?

Throughput

Throughput

- ❑ Measured in Bits/Sec
- ❑ Capacity: Nominal Throughput
- ❑ Throughput: Realistic
- ❑ Bottleneck determines the end-to-end throughput



Net end-to-end capacity = 10 Mbps

Actual throughput will be less due to sharing and overhead.

Student Questions

- ❑ Can you define overhead?
Overhead = Throughput lost due to Packet headers and delays caused by routing.
We discuss these in the next few slides.
- ❑ Is throughput a unidirectional measurement, or does it take into account two opposite and simultaneous data streams?
Throughput on each side is measured and may be different.
- ❑ What causes overhead?
Packet headers, routing messages are examples of overhead.
- ❑ What sorts of bottlenecks exist limiting E2E throughput?
Slow links, slow routers, slow end systems.
- ❑ Can the total throughput (read and write) exceed the bandwidth of a network?
Throughput cannot exceed capacity.
- ❑ What's the difference between throughput, capacity, and bandwidth?
Bandwidth relates to frequency. Capacity is the nominal throughput.

Loss Rate

- ❑ Queuing \Rightarrow Buffer overflow
- ❑ Bit Error Rate on the link
- ❑ Lost packets are retransmitted by the previous node or the source

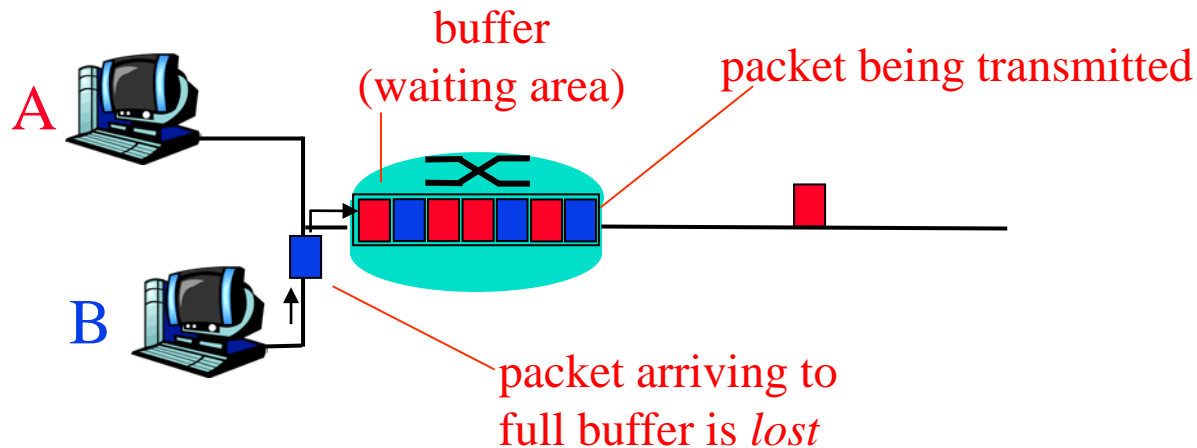

Student Questions

- ❑ Is there any potential way to reduce the loss rate in wireless transmission?

Use coding with lower bits/Hz.

- ❑ In a multi-hop connection such as the one shown in the figure, would packets travel at 10 Mbps over the whole link, or will the throughput change between each node?

Throughput cannot exceed the capacity of intermediate links and nodes.

- ❑ Is the throughput of a network equivalent to the speed of that network?

Speed=Capacity. Throughput=Actual output.

Packet Switching Delay

1. **Processing Delay:** Check packets, decide where to send, etc.
2. **Queuing Delay:** Wait behind other packets
3. **Transmission Delay:** First-bit out to last-bit out on the wire
= **Packet Length/bit rate**
4. **Propagation Delay:** Time for a bit to travel from in to out
= **Distance/speed of signal**
5. **Speed of Signal:** **300 m/μs** light in vacuum, **200 m/μs** light in fiber, **250 m/μs** electricity in copper cables

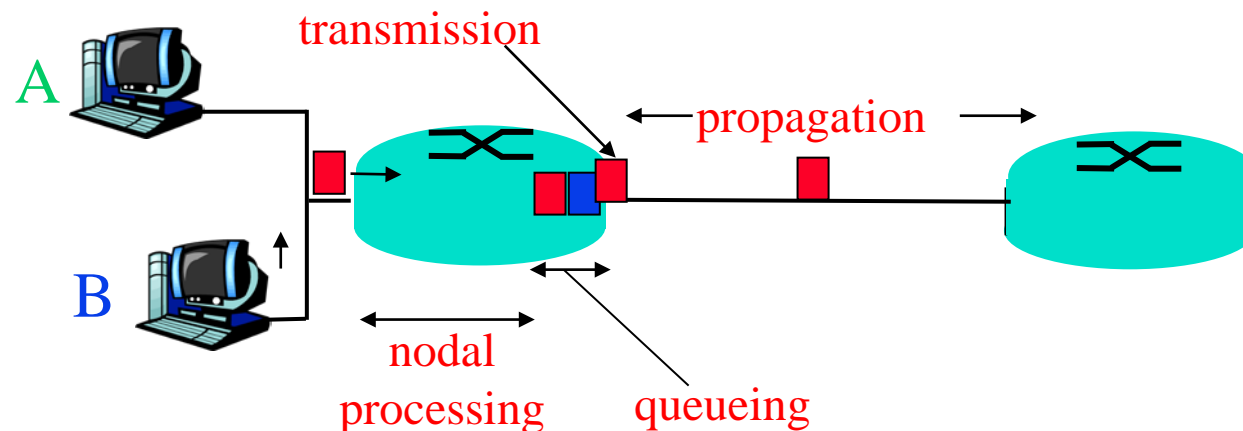

Student Questions

- ❑ Optical signal travels faster than electricity because light can carry intensive signals on the fiber?

Optical signal in fiber travels slower than electricity due to refractive index of the fiber.

- ❑ Optical fibers have larger capacity, and copper cables have less delay, is that correct?

Yes.

- ❑ Does wired always better than wireless in throughput, delay, and loss rate?

For the same cost, yes. Some wireless networks are faster than some wired networks but they are more expensive.

- ❑ Is propagation delay always happen "after" transmission delay? Do we have to put every bit on the wire first before the first bit is sent to the destination, or can we send it as we go?

Bits cannot be stopped on the wire. They travel as soon as enter the wire.

- ❑ Does the delay affect the throughput?
Two metrics have a complex relationship. They do not affect each other.

Packet Switching Delay: Example

- ❑ 1500 Byte packets on 10 Mbps Ethernet, 1km segment
- ❑ Transmission Delay = $1500 \times 8 / 10 \times 10^6 = 1200 \mu\text{s} = 1.2\text{ms}$
- ❑ Propagation delay = $1000 \text{ m} / 2.5 \times 10^8 = 4 \mu\text{s}$

Student Questions

- ❑ Will there be any sort of formula sheet accompanying our exams for math *questions where they may be relevant?*

One cheat sheet of 8.5x11" paper is allowed in the exam. But you will be better off remembering some of the common constants and formulas.

- ❑ Does 2.5×10^8 come from electricity speed? Are we assuming Ethernet using a copper cable?

Yes.

- ❑ Are all the delays series connection or parallel connection?

Delays on a series of links add up.

- ❑ Which kind of delay has the greatest impact on the signal transmission?

Depends whichever is larger.

- ❑ What causes packets to get lost in wired mediums?

Bit errors.

Delay Example (CBR Circuits)

- ❑ How long would it take to send a file of 640,000 bits from host A to host B over a circuit-switched network?
 - All links are 1.536 Mbps
 - Each link is shared by 24 users
 - 500 ms to establish end-to-end circuit
- ❑ Per User Rate = $1536/24 = 64$ kbps
- ❑ Time to transfer = $640\text{kb}/64\text{kb} = 10$ s
- ❑ Total time = $.5$ s + 10 s = 10.5 s

Student Questions

❑ Are we assuming the link is using TDM? Wouldn't every user get 1.536 Mbps if it were FDM?
In FDM, the bit/sec depend on Hertz. Hertz is the unit of frequency. So dividing frequency divides the bit rate among users even in FDM.

❑ Don't quite understand why FDM will divide the bit rate as well as TDM, could you give more explanations about it?

Two users sharing 10 MHz for 1 second. Assume one bit/Hz as an example. Each will get 5 Mbps for 1 second using FDM or 10 Mbps for 0.5 s using TDM.

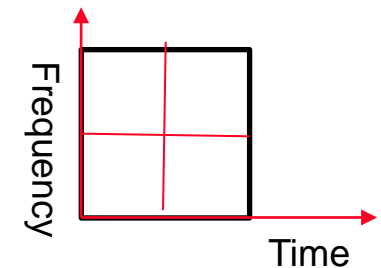

Homework 1B: Network Performance

P5 [14 points]: Consider two hosts, A and B, connected by a single link of rate R bps. Suppose that the two hosts are separated by m meters, and suppose the propagation speed along the link is s meters/sec. Host A is to send a packet of size L bits to Host B.

- A. Express the propagation delay, d_{prop} in terms of m and s
- B. Determine the transmission time of the packet d_{trans} in terms of L and R .
- C. Ignoring processing queuing delays, obtain an expression for the end-to-end delay
- D. Suppose Host A begins to transmit the packet at time $t=0$. At time $t=d_{trans}$ where is the last bit of the packet?
- E. Suppose d_{prop} is greater than d_{trans} . At time $t=d_{trans}$, where is the first bit of the packet?
- F. Suppose d_{prop} is less than d_{trans} , at time $t=d_{trans}$, where is the first bit of the packet
- ⇒ G. Suppose $s=3 \times 10^8$ m/s, $L=290$ bits, and $R=60$ kbps,. Find the distance m so that d_{prop} equals d_{trans} .

Student Questions

Protocol Layers

- ❑ Problem: Philosophers in different countries speak different languages. The Telex system works only with English.

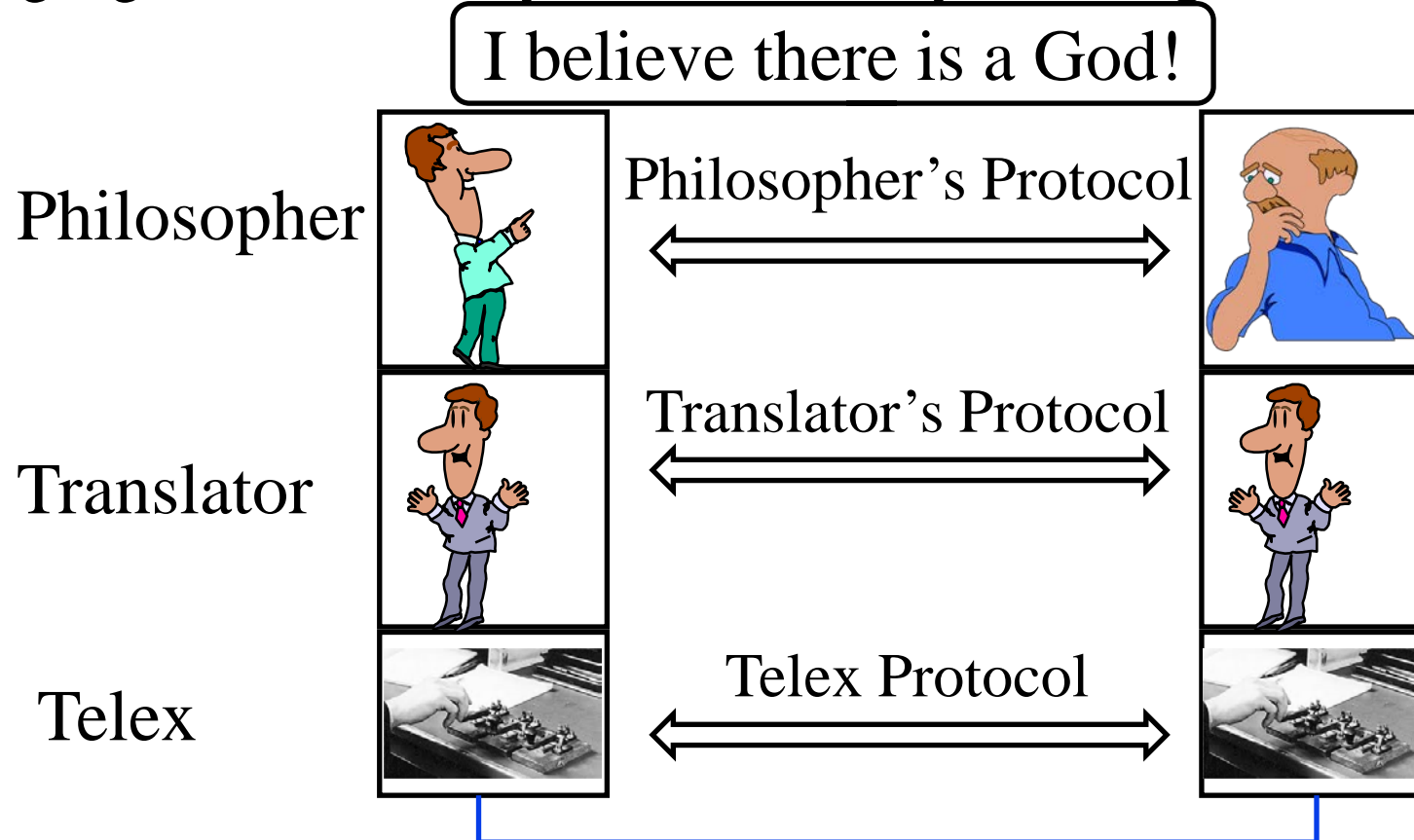

Student Questions

- ❑ Are there any protocols between philosopher and translator, or between translator and telex?

Yes, those are called API's. Not protocols.

What is a Networking Protocol?

- ❑ Network protocols define the format of messages, their meanings, sequence, and actions



Student Questions

- ❑ Is there any specific order for the layers?
For example, the session layer has to be before the transport layer.
Yes.
- ❑ Is combining or separating application, presentation, and session layer dependent on the protocol?
Yes. TCP combines all of these.
- ❑ Which layers of OSI is the router we use on?
Layer 3.
- ❑ Should we see the model top to bottom or bottom to top?
This textbook covers top-down. Other books cover bottom-up.
- ❑ In a modern server, which layers are handled by the operating system?
Up to Layer 4.
- ❑ Layer 5 was composed of application, presentation, and session. Is there any connection between them?
Yes. All depend on the application.

ISO/OSI Reference Model

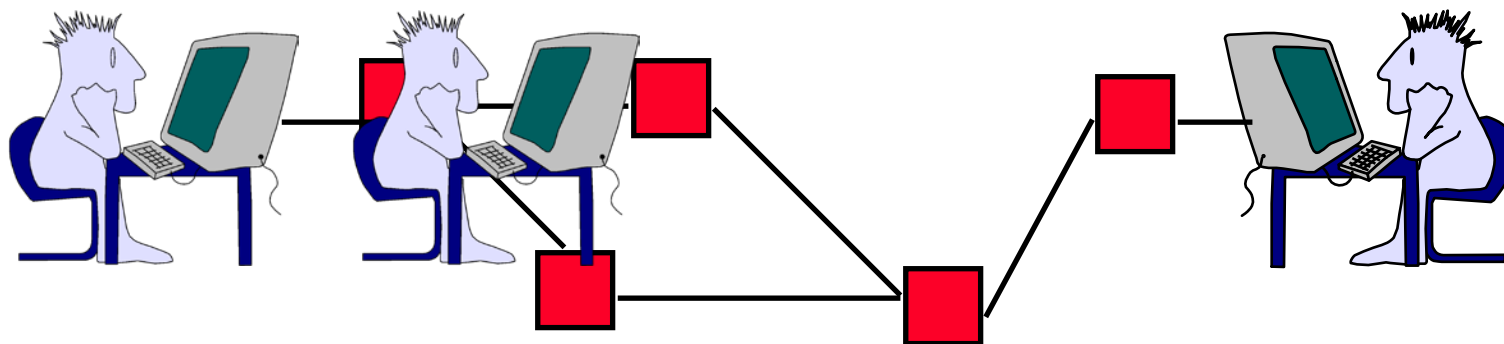
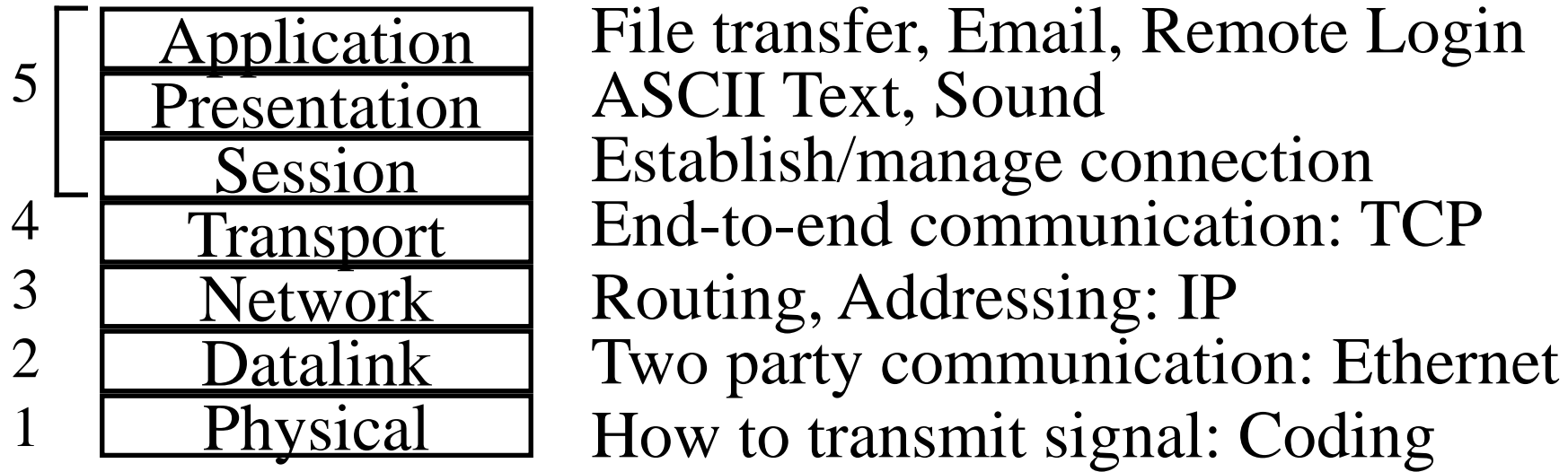

Student Questions

- Layer 2 and Layer 4 sounds pretty similar to me. Both of them are focusing on communication, could you help me distinguish them?

One link vs. one path

A path has many links on the way. Same functions require different solutions since the latencies are different.

- Would you clarify what the data link and session levels are responsible for?

Data link = One link

Session = One application

- Is there an example of a "Session protocol" or is that not a thing at all?

Mail, HTTP are examples of applications. In TCP, application, presentation, and session layers are combined as one.

- What layers connection does "ping" check? Sometimes we can ping a website, but we cannot see the content of the website in the browser.

Layer 3

- Are layers interconnecting with each other before communicating?

As soon as a layer has been initialized, it is ready to talk.

Service and Protocol Data Units

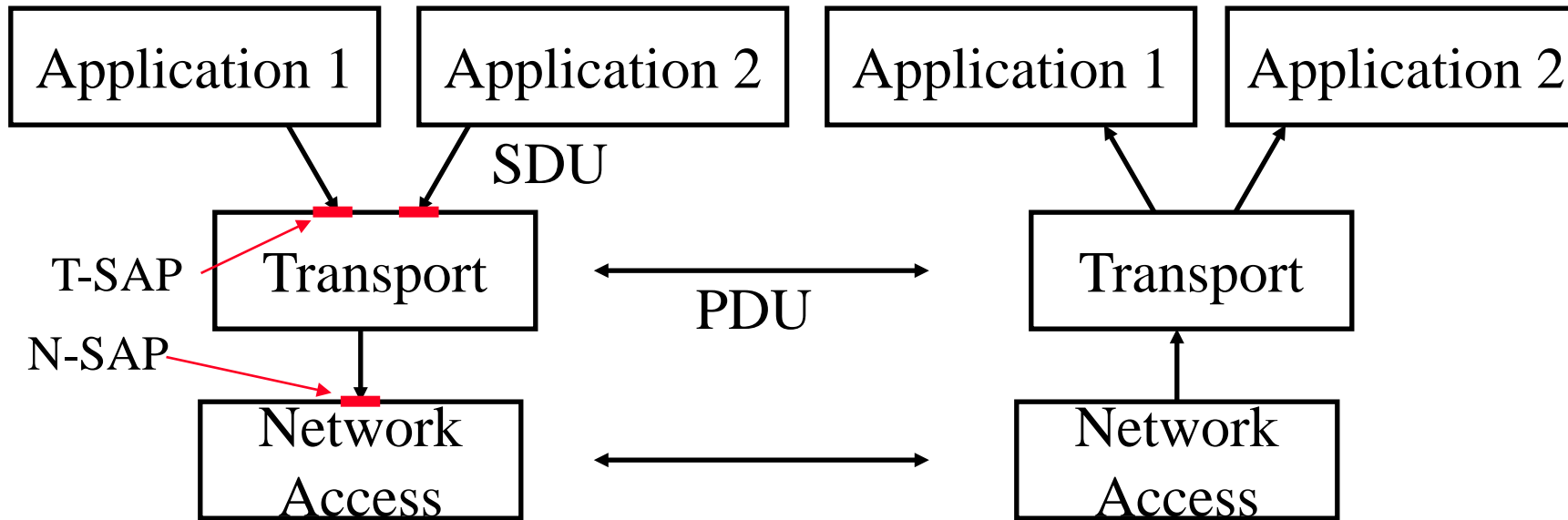

- ❑ **S**ervice **A**ccess **P**oints (SAPs)
- ❑ **S**ervice **D**ata **U**nits (SDUs)
- ❑ **P**rotocol **D**ata **U**nits (PDUs)

Student Questions

- ❑ What are Service Access Points (SAPs)?
See updated figure on the left.
Ports are examples of T-SAPs (Transport SAPs)
- ❑ Could SAP be described as an API of a different layer?
Yes. SAP=API of a layer.
- ❑ You said SDU goes down vertically over the layer, and PDU goes horizontally over the same layers. But I remember the procedure of data transmission is to first go down to the physical layer, the router, then the physical layer of another host when it finishes. This is contradicted to what the slide refers to. Could you explain?
You are right. The PDUs are units of information exchanged by modules of one layer. But they have to down vertically, travel horizontally, then vertically up.
- ❑ Do the arrows between Transport and Network Access imply that Transport PDUs are bidirectional while Network PDUs are not?
Corrected.

Service Data Unit (SDU)

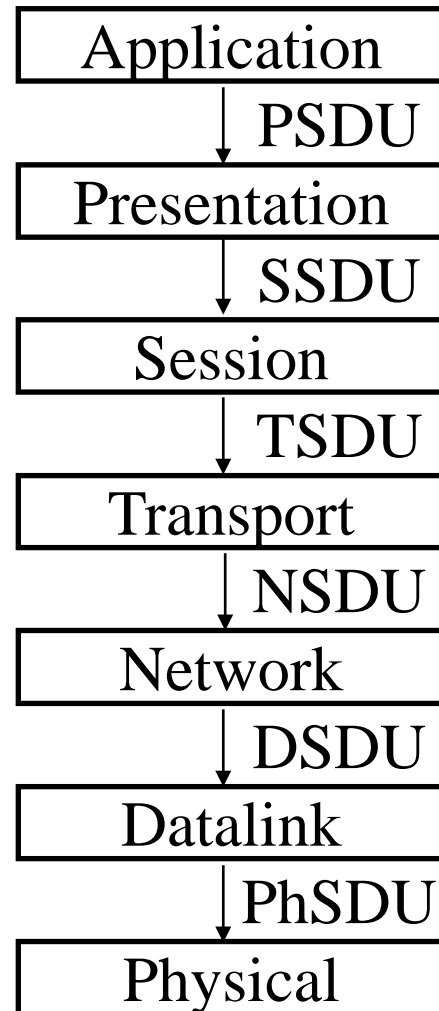

Student Questions

- Can a layer communicate only with layers directly above and below it or can it skip layers?

In a strictly layered architecture, the communication is between successive layers only. Although not common, cross-layer communication has been studied and applied for some special situations.

- Are the SDU and PDU for each layer different actual bit patterns? Is the incoming SDU translated into a PDU for that protocol layer, which is then translated to the SDU for the next layer and transmitted?

Yes, SDU and PDUs are different for different layers. PDUs are formed by combining or fragmenting SDUs. Each PDU has a header that is understood by the other side.

- For PDU, does one layer send data directly to another similar layer, or just transmit to the bottom layer vertically, then sent in physical layer, finally go up vertically to the target layer?
- Yes. PDUs go to the bottom layer and then across.*
- Why can't they just use one type of data unit to unify SDU and PDU?

They are different.

Protocol Data Unit (PDU)

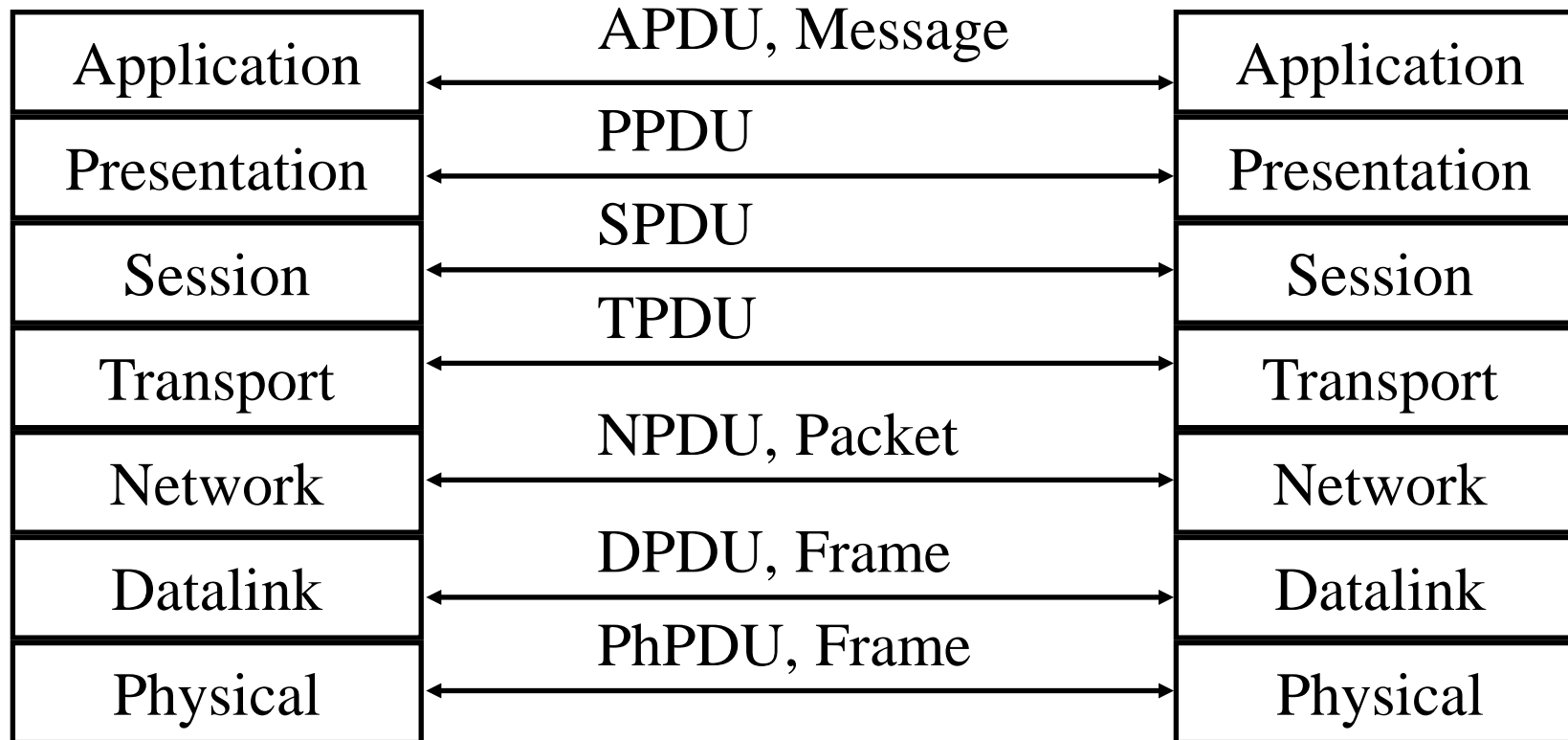

Student Questions

- What is the difference between SDUs and PDUs?
Service data units go down vertically between different layers.
Protocol data units flow horizontally between the entities in the same layer.

TCP/IP Reference Model

- ❑ TCP = Transmission Control Protocol
- ❑ IP = Internet Protocol (Routing)

TCP/IP Ref Model

Application
Transport
Internetwork
Host to Network
Physical

TCP/IP Protocols

FTP	Telnet	HTTP
TCP		UDP
IP		
Ethernet	Point-to-Point	Packet Radio
Coax	Fiber	Wireless

Student Questions

- ❑ TCP is "Transmission Control Protocol" and IP is "Internet Protocol", is "TCP/IP Protocol" not good since "Protocol" is repeated?

TCP/IP is a "protocol suite"

OSI vs TCP/IP

OSI	TCP/IP
Application	Application
Presentation	
Session	
Transport	Transport (host-to-host)
Network	Internet
Data Link	Network Access
Physical	Physical

Student Questions

- ❑ How is the session layer from the OSI model split up between the application and transport layers of the TCP/IP model?

Some functions of session layer are in TCP and some are not. It doesn't really matter since TCP is now universal along with a few other similar transports.

- ❑ What is the difference between the OSI model and TCP/IP model? I've looked at so many different websites' explanations but still don't understand...

OSI was done after TCP/IP. However, by the time OSI was partially completed, TCP/IP was universally implemented. So OSI is more methodical but non-existent. TCP/IP is less methodically but everywhere.

- ❑ Is the TCP/IP model used now, and the OSI model is obsolete?

Yes.

OSI vs TCP/IP

OSI	TCP/IP
Application	Application
Presentation	
Session	
Transport	Transport (host-to-host)
Network	Internet
Data Link	Network Access
Physical	Physical

Student Questions

- How is the session layer from the OSI model split up between the application and transport layers of the TCP/IP model?

Some functions of session layer are in TCP and some are not. It doesn't really matter since TCP is now universal along with a few other similar transports.

- What is the difference between the OSI model and TCP/IP model? I've looked at so many different websites' explanations but still don't understand...

OSI was done after TCP/IP. However, by the time OSI was partially completed, TCP/IP was universally implemented. So OSI is more methodical but non-existent. TCP/IP is less methodically but everywhere.

- ❖ Should we be comfortable with both the OSI and TCP/IP models, or is it sufficient to only be comfortable with the TCP/IP model?

You should know as much about the OSI model as discussed in this class video and Q&As.

OSI vs TCP Reference Models

- ❑ OSI introduced concept of services, interface, protocols. These were force-fitted to TCP later
⇒ It is not easy to replace protocols in TCP.
- ❑ In OSI, reference model was done before protocols. In TCP, protocols were done before the model
- ❑ OSI: Standardize first, build later
TCP: Build first, standardize later
- ❑ OSI took too long to standardize. TCP/IP was already in wide use by the time.
- ❑ OSI became too complex.
- ❑ TCP/IP is not general. Ad hoc.

Student Questions

- ❑ Does there not need to be one agreed-upon model among all telecommunication services/companies?

Everyone's needs are different.

PDU's in TCP/IP Architecture

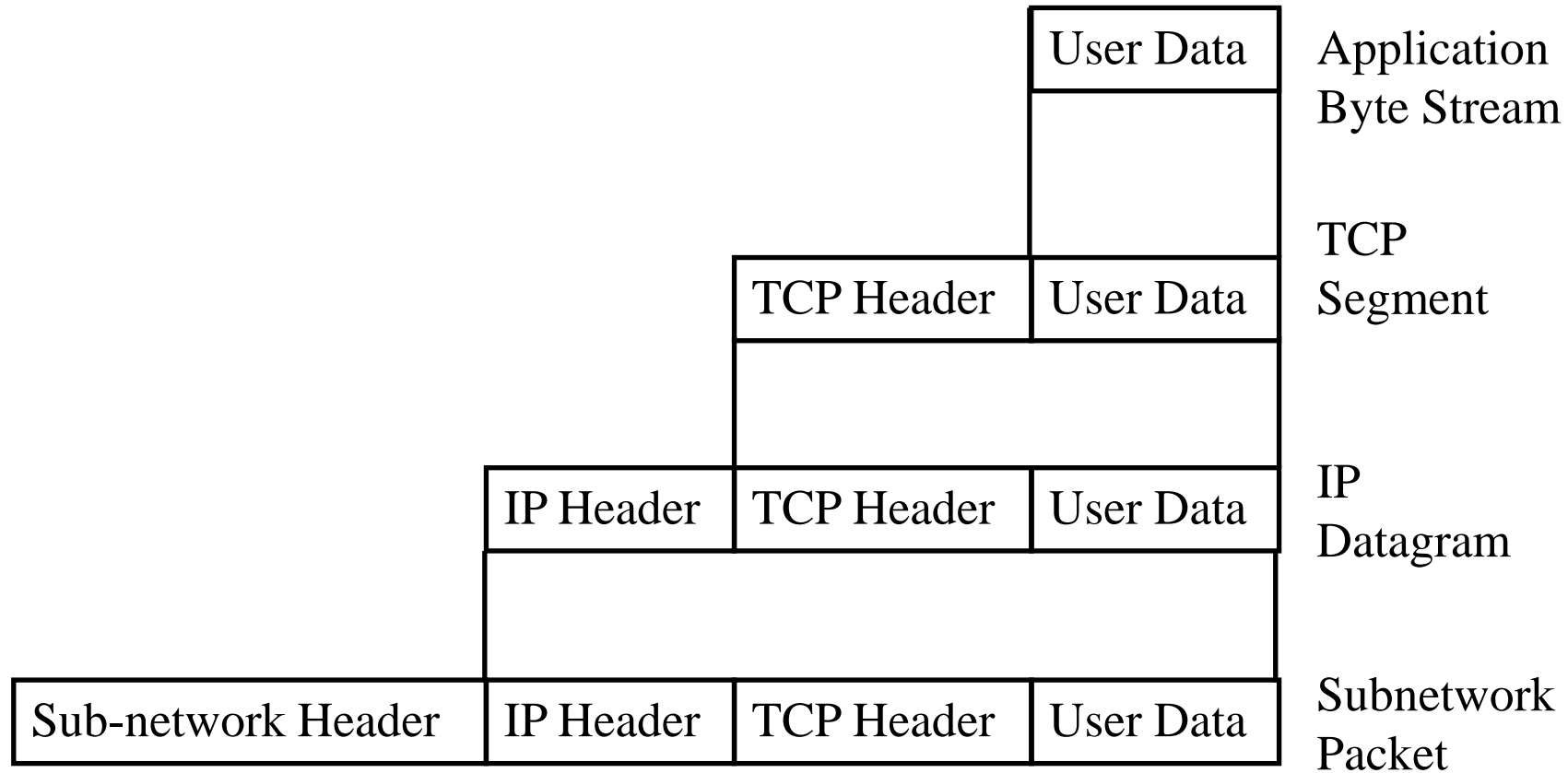

Student Questions

- ❑ If the TCP is not full yet, can it still send the message?

Yes, based on a timer.

- ❑ What does header mean?

The header contains information that the other side needs.

TCP/IP Applications

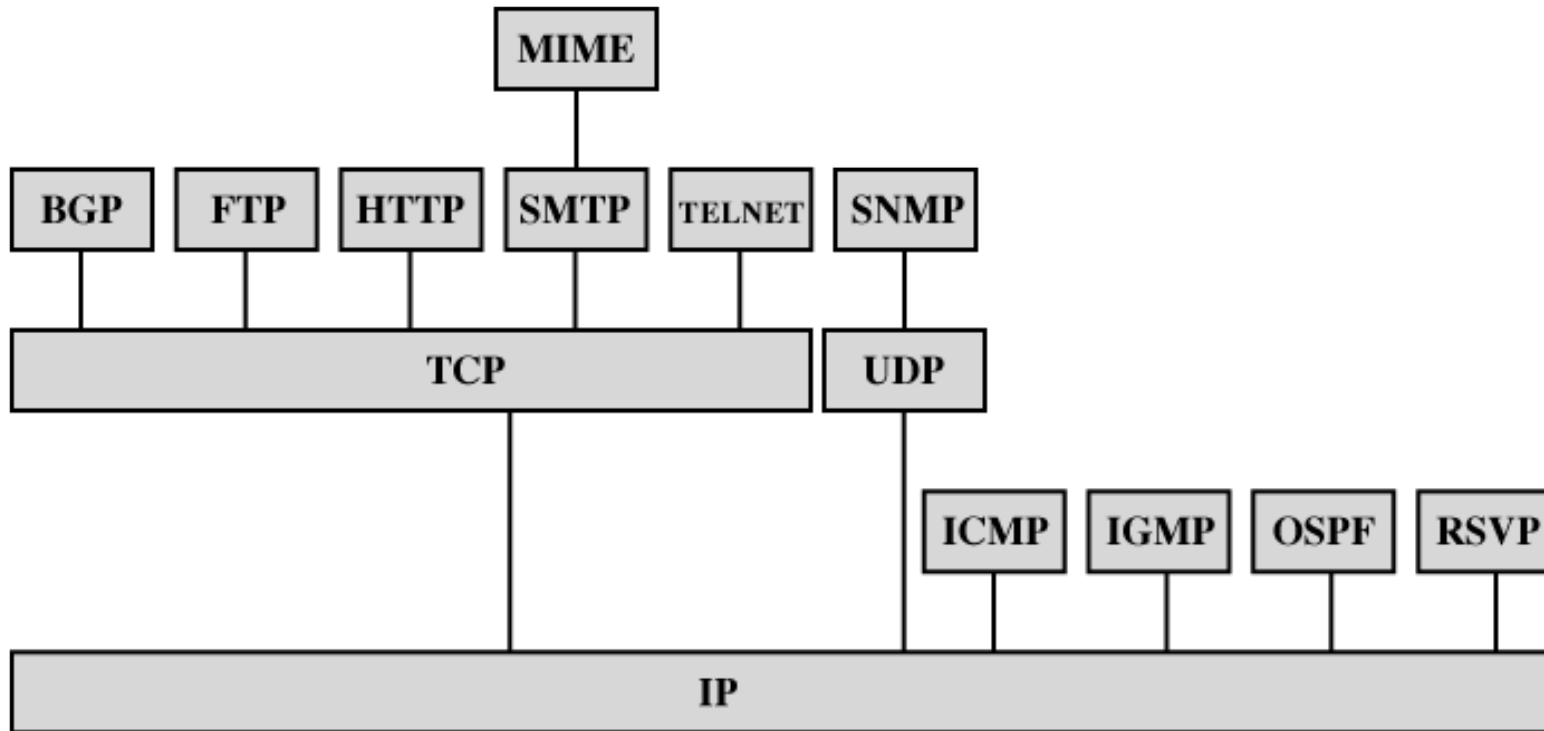

BGP = Border Gateway Protocol
FTP = File Transfer Protocol
HTTP = Hypertext Transfer Protocol
ICMP = Internet Control Message Protocol
IGMP = Internet Group Management Protocol
IP = Internet Protocol
MIME = Multi-Purpose Internet Mail Extension

OSPF = Open Shortest Path First
RSVP = Resource ReSerVation Protocol
SMTP = Simple Mail Transfer Protocol
SNMP = Simple Network Management Protocol
TCP = Transmission Control Protocol
UDP = User Datagram Protocol

Student Questions

Will we be expected to memorize all of these protocols and if they run on TCP/IP/SMTP/etc?
Not yet. However, in later modules, we cover some of these protocols. Then you will need to know what runs below and above. This is just a preview and lists too many protocols.

Is it correct that because the HTTP layer is above TCP, it is responsible for giving the TCP layer the properly formatted message?

Yes.

Network Security

- ❑ Security Components
- ❑ Types of Malware
- ❑ Types of Attacks
- ❑ Buffer Overflows
- ❑ Distributed DoS Attacks

Student Questions

- ❑ In my background, I found any attack on any part of an arbitrary company's security system starts with loading up the main site and seeing what's publicly available to look at. Checking the place out often leads to best-case some goal achieved and worst-case information useful for an exploit, I have heard at times and in places before. Why wouldn't simply looking around be the first step of an arbitrary attack, network security-related or otherwise?

Snooping is the first step of an attack.

Security Components

- ❑ **Confidentiality**: Need access control, Cryptography, Existence of data
- ❑ **Integrity**: No change, content, source, prevention mechanisms, detection mechanisms
- ❑ **Availability**: Denial of service attacks,
- ❑ Confidentiality, Integrity and Availability (**CIA**)



Student Questions

- ❑ Does maintaining a security component (e.g., integrity) require the knowledge of the result (e.g., file has been verified with a checksum), or is it enough to know that you have enacted countermeasures and you have not detected any tampering?

Maintaining a component requires that that component be verified and ensured.

Types of Malware

- ❑ **Viruses:** Code that *attaches* itself to programs, disks, or memory to propagate itself.
- ❑ **Worms:** Installs copies of itself on other machines on a network, e.g., by finding user names and passwords
- ❑ **Trojan horses:** Pretend to be a utility. Convince users to install on PC.
- ❑ **Spyware:** Collect personal information

This is not a complete list.

Student Questions

- ❑ Worms and viruses don't sound mutually exclusive based on the definitions given. The difference is only in how they arrive on your system?

Yes, viruses can fly but worms can only walk.

- ❑ Can viruses or worms be transported through trojan horses?

Yes.

Types of Attacks

- ❑ **Denial of Service (DoS):** Flooding with traffic/requests
- ❑ **Buffer Overflows:** Error in system programs. Allows hacker to insert his code in to a program.
- ❑ **Malware**
- ❑ **Brute Force:** Try all passwords.
- ❑ **Port Scanning:**
 - ⇒ Disable unnecessary services and close ports
- ❑ **Network Mapping**

Student Questions

- ❑ How would you protect against something like a Buffer Overflow attack on the network layer?

Good code writing.

- ❑ How to do port scanning?

We will show you later in the security chapter.

Distributed DoS Attacks

- ❑ **Tribe Flood Network** (TFN) clients are installed on compromised hosts.
- ❑ All clients start a simultaneous DoS attack on a victim on a trigger from the attacker.
- ❑ **Trinoo** attack works similarly. Use UDP packets. Trinoo client report to Trinoo master when the system comes up.
- ❑ **Stacheldraht** uses handlers on compromised hosts to receive encrypted commands from the attacker.

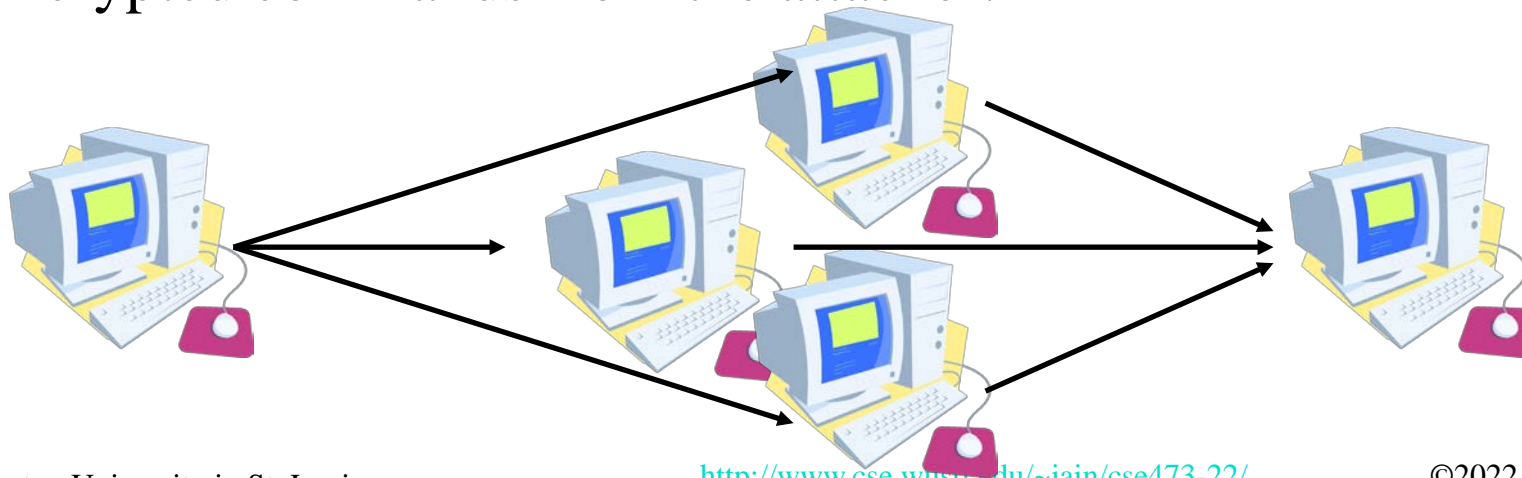

Student Questions

History of Internet

- ❑ 1961: Kleinrock developed queueing theory. Showed effectiveness of packet-switching
- ❑ 1964: Baran's report on packet-switching in military nets
- ❑ 1967: ARPAnet conceived by Advanced Research Projects Agency
- ❑ 1969: First ARPAnet node operational
First Request for Comment (RFC)

www.ietf.org

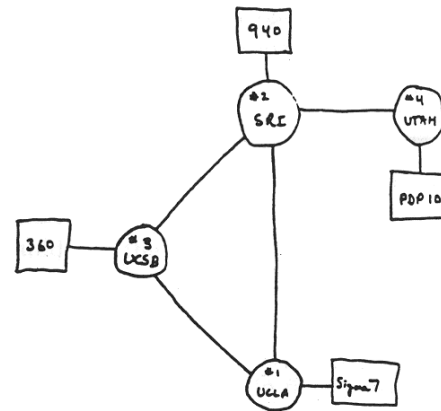

THE ARPA NETWORK

Student Questions

History of Internet (Cont)

- ❑ Early 1990s: HTML, HTTP: Berners-Lee
- ❑ 1994: Mosaic, later Netscape
- ❑ 2007:
 - ~500 million hosts
 - Voice, Video over IP
 - P2P applications: BitTorrent (file sharing) Skype (VoIP), PPLive (video)
 - Video applications: YouTube, gaming
 - Wireless, Mobility

Student Questions

- ❑ It seems like the internet is Point to Point. Is this true?
No. In some places, it is broadcast, e.g., in Wi-Fi.

Key Concepts

- ❑ **Internet Protocol (IP):** Protocol
- ❑ **Address:** All systems have an IP address, for example, 125.36.47.23
- ❑ **Name:** All systems have a human readable name, e.g., scorpio.cec.wustl.edu, ibm.com.
- ❑ Technically called **DNS (domain name systems)** name. Details will be introduced later.
- ❑ **IETF:** Internet Engineering Task Force. Make standards for Internet. IETF.org
- ❑ **RFC:** Request for comments. Documents that describe Internet protocols.

Student Questions

- ❑ Are IP address and name identical?
Not identical. They are related.
- ❑ What is the difference between IPv4 and IPv6?
Version 4 and Version 6.
- ❑ How do you convert from DNS to IP?
See Chapter 2.

Summary

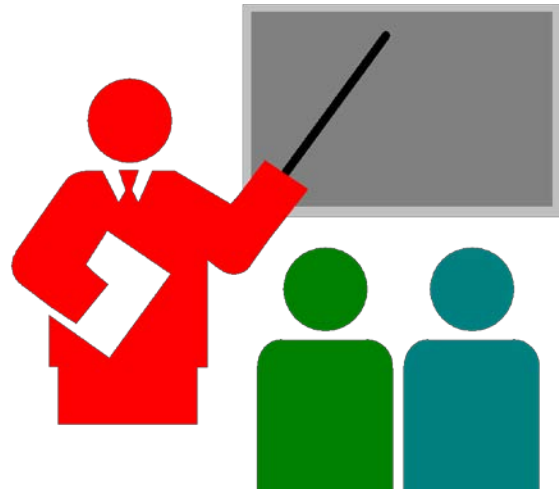

1. Most common medium is **UTP**, wireless, fiber
2. **Internet** is a network of networks
3. Enterprise, **access**, and **core** networks
4. Performance Measures: **Delay**, **Throughput**, **Loss Rate**
5. Protocol Layers: **ISO** and **TCP/IP** reference models

Ref: Read entire Chapter 1 and try R1-R28 8th Edition.

Student Questions

- ❑ Is homework due before class, after class, or do we have some time?

Home works are due at 1PM on the due date.

- ❑ Why is ipv6 so scarcely used?

Old habits die hard. Too much deployed equipment.

Lab 1: Internet and Wireshark

[6 points]

1. Find the IP address of your computer (ipconfig, ifconfig)
2. Find the IP address of www.wustl.edu (ping)
3. Measure delay from your computer to www.wustl.edu (ping or tracert)

For all cases submit the screen snapshot showing the command used and the output. (Use Alt-Print-screen to capture a window to clipboard and then paste to word)

Student Questions

- How do you measure delay from computer to website? What is tracert?

Type these commands in a Windows command prompt box and see what happens. E.g., try 'tracert www.wustl.edu' They work similarly in Mac and Linux.

- What do you mean by the internet address of google there? Do you mean IP address?

Yes.

Lab 1 (Cont)

4. Download Wireshark,

<https://www.wireshark.org/download.html>

- Install it on your laptop.
- If you are using a windows computer, you will also need npcap (Packet Capture Tool) from nmap.org
- Start Wireshark and start logging
- Tracert to www.google.com
- Stop logging. Capture the current screen and submit.
Do not worry about the part of the trace that is no longer on the screen.
- Q1: List 3 protocols that you see in the packet trace.
- Q2: What is the internet address of www.google.com from the trace?

Please see Slide 1-63 for additional hints on this lab

Student Questions

Reading List

- Read Chapter 2 of the textbook for the next class.

Student Questions

Acronyms

- ❑ APDU Application Packet Data Unit
- ❑ ARPAnet Advanced Research Project Agency Network
- ❑ ASCII American Standard Code for Information Interchange
- ❑ AT&T American Telephone and Telegraph
- ❑ CBR Constant Bit Rate
- ❑ CIA Confidentiality, Integrity, Access
- ❑ DNS Domain Name Service
- ❑ DoS Denial of Service
- ❑ DPDU Datalink Packet Data Unit
- ❑ DSDU Datalink Service Data Unit
- ❑ DSL Digital Subscriber Line
- ❑ FDM Frequency Division Multiplexing
- ❑ FTP File Transfer Protocol
- ❑ FTTH Fiber to the host
- ❑ GHz Giga Hertz
- ❑ HFC Hybrid Fiber Coax

Student Questions

Acronyms (Cont)

- ❑ HTML Hyper-Text Markup Language
- ❑ HTTP Hyper-Text Transfer Protocol
- ❑ IEEE Institution of Electrical and Electronics Engineers
- ❑ IETF Internet Engineering Task Force
- ❑ IP Internet Protocol
- ❑ ISO International Standards Organization
- ❑ ISP Internet Service Provider
- ❑ kHz Kilo Hertz
- ❑ LAN Local Area Network
- ❑ LTE Long Term Evolution
- ❑ MAN Metropolitan Area Network
- ❑ MHz Mega Hertz
- ❑ NPDU Network Protocol Data Unit
- ❑ NSDU Network Service Data Unit
- ❑ OSI Open System Interconnect
- ❑ PC Personal Computer

Student Questions

Acronyms (Cont)

- ❑ PDU Protocol Data Unit
- ❑ PhSDU Physical Service Data Unit
- ❑ PON Passive Optical Network
- ❑ PPDU PHY protocol data unit
- ❑ PSDU PHY Service data unit
- ❑ RFC Request for Comments
- ❑ SAPs Service Access Points
- ❑ SDU Service Data Units
- ❑ SPDU Session Protocol Data Unit
- ❑ SSDU Session Service Data Unit
- ❑ STP Shielded Twisted Pair
- ❑ TCP Transmission Control Protocol
- ❑ TDM Time Division Multiplexing
- ❑ TFN Tribe Flood Network
- ❑ TP Twisted Pair
- ❑ TSDU Transport Service Data Unit

Student Questions

Acronyms (Cont)

- ❑ TV Television
- ❑ UDP Universal Data Protocol
- ❑ UTP Unshielded Twisted Pair
- ❑ VoIP Voice over IP
- ❑ WAN Wide Area Network
- ❑ WiFi Wireless Fidelity

Student Questions

Scan This to Download These Slides



Raj Jain

<http://rajjain.com>

http://www.cse.wustl.edu/~jain/cse473-22/i_1cni.htm

Student Questions

Do we still use broadcast technology in today's world, or is it directed?

Wireless is mostly broadcast.

What is packet loss? What causes packet loss?

Errors.

I don't quite understand the difference between point to point and switches since they look almost the same. And you said 99.9% uses a star as the pattern. Does that mean the switch is the updated version of a star pattern?

Switches may be centers of stars. But, switches may be connected to other switches in any topology.

For the circuit, does it mean if I want to connect to Amazon, Amazon has to be online first, then we can build the connection and talk?

Yes.

Which types of networks are more common, and how can they be identified?

Please wait till you learn about different network technologies.

Related Modules



CSE 567: The Art of Computer Systems Performance Analysis

https://www.youtube.com/playlist?list=PLjGG94etKypJEKjNAa1n_1X0bWWNyZcof

CSE473S: Introduction to Computer Networks (Fall 2011),

https://www.youtube.com/playlist?list=PLjGG94etKypJWOSPMh8Azcg5e_10TiDw



CSE 570: Recent Advances in Networking (Spring 2013)

<https://www.youtube.com/playlist?list=PLjGG94etKypLHyBN8mOgwJLHD2FFIMGq5>

CSE571S: Network Security (Spring 2011),

<https://www.youtube.com/playlist?list=PLjGG94etKypKvzfVtutHcPFJXumyyg93u>



Video Podcasts of Prof. Raj Jain's Lectures,

<https://www.youtube.com/channel/UCN4-5wzNP9-ruOzQMs-8NUw>

Student Questions

Lab 1: Hints

❑ The HTTP traffic may not show in Wireshark if:

1. You may not have installed npcap
2. The websites you are doing your test on use HTTPS (TLS). In this case, Wireshark will identify the protocol as a TLS packet, not an HTTP packet.
3. If you are using Chrome, Edge, or any browser based on Chromium engine, the traffic when accessing google.com will show as QUIC because Google uses QUIC for their websites. Also, this is valid for other websites that use QUIC.

❑ If you want to see the content of A TLS packet, follow this guide:

<https://wiki.wireshark.org/TLS#:~:text=Step-by-step%20instructions%20to%20decrypt%20TLS%20traffic%20from%20Chrome,from%20step%202%20is%20created.%20More%20items...%20>

Student Questions