

Random Number Generation

Raj Jain
Washington University
Saint Louis, MO 63130
Jain@cse.wustl.edu

Audio/Video recordings of this lecture are available at:

<http://www.cse.wustl.edu/~jain/cse567-13/>



- ❑ Desired properties of a good generator
- ❑ Linear-congruential generators
- ❑ Tausworthe generators
- ❑ Survey of random number generators
- ❑ Seed selection
- ❑ Myths about random number generation

Random-Number Generation

- ❑ Random Number = Uniform (0, 1)
- ❑ Random Variate = Other distributions
= Function(Random number)

A Sample Generator

$$x_n = f(x_{n-1}, x_{n-2}, \dots)$$

- For example,

$$x_n = 5x_{n-1} + 1 \pmod{16}$$

- Starting with $x_0=5$:

$$x_1 = 5(5) + 1 \pmod{16} = 26 \pmod{16} = 10$$

- The first 32 numbers obtained by the above procedure 10, 3, 0, 1, 6, 15, 12, 13, 2, 11, 8, 9, 14, 7, 4, 5 10, 3, 0, 1, 6, 15, 12, 13, 2, 11, 8, 9, 14, 7, 4, 5.

- By dividing x's by 16:

0.6250, 0.1875, 0.0000, 0.0625, 0.3750, 0.9375, 0.7500,
0.8125, 0.1250, 0.6875, 0.5000, 0.5625, 0.8750, 0.4375,
0.2500, 0.3125, 0.6250, 0.1875, 0.0000, 0.0625, 0.3750,
0.9375, 0.7500, 0.8125, 0.1250, 0.6875, 0.5000, 0.5625,
0.8750, 0.4375, 0.2500, 0.3125.

Terminology

- ❑ **Seed** = x_0
- ❑ **Pseudo-Random**: Deterministic yet would pass randomness tests
- ❑ Fully Random: Not repeatable
- ❑ **Cycle length, Tail, Period**

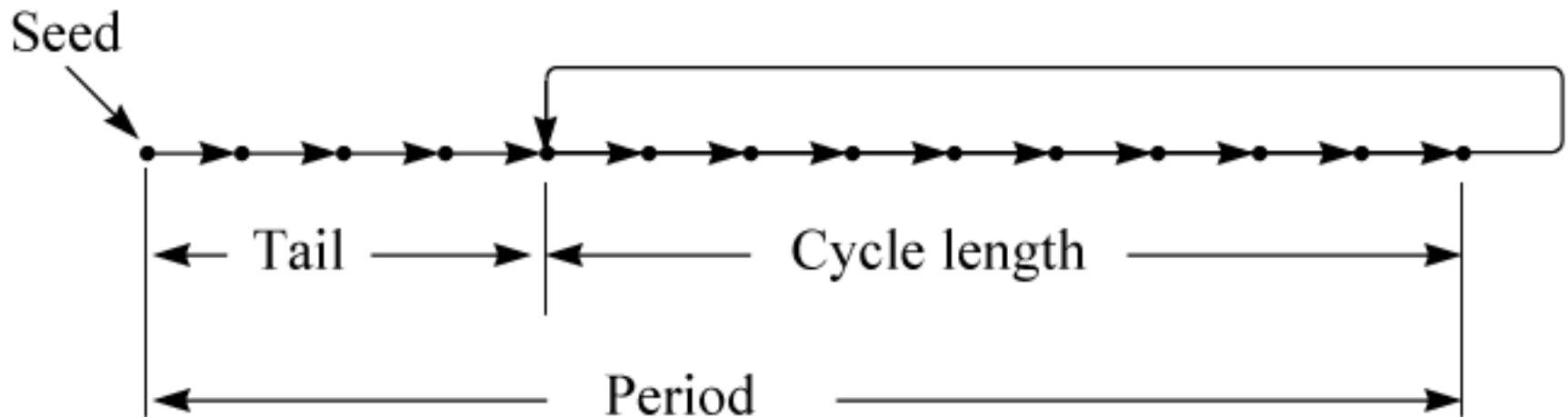

Properties of a Good Generator

- ❑ It should be efficiently computable.
- ❑ The period should be large.
- ❑ The successive values should be independent and uniformly distributed

Types of Generators

- ❑ Linear congruential generators
- ❑ Tausworthe generators
- ❑ Extended Fibonacci generators
- ❑ Combined generators

Linear-Congruential Generators

- ❑ Discovered by D. H. Lehmer in 1951
- ❑ The residues of successive powers of a number have good randomness properties.

$$x_n = a^n \text{ mod } m$$

Equivalently,

$$x_n = ax_{n-1} \text{ mod } m$$

a = multiplier

m = modulus

LCG (Cont)

- ❑ Lehmer's choices: $a = 23$ and $m = 10^8 + 1$
- ❑ Good for ENIAC, an 8-digit decimal machine.
- ❑ Generalization:

$$x_n = ax_{n-1} + b \pmod{m}$$

- ❑ Can be analyzed easily using the theory of congruences
⇒ Mixed Linear-Congruential Generators
or Linear-Congruential Generators (LCG)
- ❑ Mixed = both multiplication by a and addition of b

Selection of LCG Parameters

- ❑ a , b , and m affect the period and autocorrelation
- ❑ The modulus m should be large.
- ❑ The period can never be more than m .
- ❑ For mod m computation to be efficient, m should be a power of 2 \Rightarrow Mod m can be obtained by truncation.

LCG Parameters (Cont)

- ❑ If b is nonzero, the maximum possible period m is obtained if and only if:
 - Integers m and b are relatively prime, that is, have no common factors other than 1.
 - Every prime number that is a factor of m is also a factor of $a-1$.
 - If integer m is a multiple of 4, $a-1$ should be a multiple of 4.
 - Notice that all of these conditions are met if $m=2^k$, $a = 4c + 1$, and b is odd. Here, c , b , and k are positive integers.

Period vs. Autocorrelation

- A generator that has the maximum possible period is called a full-period generator.

$$x_n = (2^{34} + 1)x_{n-1} + 1 \pmod{2^{35}}$$

$$x_n = (2^{18} + 1)x_{n-1} + 1 \pmod{2^{35}}$$

- Lower autocorrelations between successive numbers are preferable.
- Both generators have the same full period, but the first one has a correlation of 0.25 between x_{n-1} and x_n , whereas the second one has a negligible correlation of less than 2^{-18}

Multiplicative LCG

- Multiplicative LCG: $b=0$

$$x_n = ax_{n-1} \bmod m$$

- Two types:

$$m = 2^k$$

$$m \neq 2^k$$

Multiplicative LCG with $m=2^k$

- ❑ $m = 2^k \Rightarrow$ trivial division
 \Rightarrow Maximum possible period 2^{k-2}
- ❑ Period achieved if multiplier a is of the form $8i \pm 3$, and the initial seed is an odd integer
- ❑ One-fourth the maximum possible may not be too small
- ❑ Low order bits of random numbers obtained using multiplicative LCG's with $m=2^k$ have a cyclic pattern

Example 26.1a

$$x_n = 5x_{n-1} \bmod 2^5$$

- Using a seed of $x_0=1$:

5, 25, 29, 17, 21, 9, 13, 1, 5,...

Period = 8 = $32/4$

- With $x_0 = 2$, the sequence is: 10, 18, 26, 2, 10,...

Here, the period is only 4.

Example 26.1b

- ❑ Multiplier not of the form $8i \pm 3$:

$$x_n = 7x_{n-1} \pmod{2^5}$$

- ❑ Using a seed of $x_0 = 1$, we get the sequence:
7, 17, 23, 1, 7,...
- ❑ The period is only 4

Multiplicative LCG with $m \neq 2^k$

- ❑ Modulus $m =$ prime number

With a proper multiplier a , period = $m-1$

Maximum possible period = m

- ❑ If and only if the multiplier a is a *primitive root* of the modulus m
- ❑ a is a primitive root of m if and only if $a^n \bmod m \neq 1$ for $n = 1, 2, \dots, m-2$.

Example 26.2

$$x_n = 3x_{n-1} \pmod{31}$$

- Starting with a seed of $x_0=1$:

1, 3, 9, 27, 19, 26, 16, 17, 20, 29, 25, 13, 8, 24, 10, 30, 28, 22,
4, 12, 5, 15, 14, 11, 2, 6, 18, 23, 7, 21, 1, ...

The period is 30

\Rightarrow 3 is a primitive root of 31

- With a multiplier of $a = 5$: 1, 5, 25, 1, ...

The period is only 3 \Rightarrow 5 is not a primitive root of 31

$$5^3 \pmod{31} = 125 \pmod{31} = 1$$

- Primitive roots of 31 = 3, 11, 12, 13, 17, 21, 22, and 24.

Schrage's Method

❑ PRN computation assumes:

- No round-off errors, integer arithmetic and no overflows
⇒ Can't do it in BASIC
- Product $a x_{n-1} > \text{Largest integer} \Rightarrow \text{Overflow}$

❑ Identity: $ax \bmod m = g(x) + mh(x)$

Where: $g(x) = a(x \bmod q) - r(x \operatorname{div} q)$

And: $h(x) = (x \operatorname{div} q) - (ax \operatorname{div} m)$

Here, $q = m \operatorname{div} a$, $r = m \bmod a$

'A div B' = dividing A by B and truncating the result.

- ❑ For all x's in the range 1, 2, ..., m-1, computing g(x) involves numbers less than m-1.
- ❑ If $r < q$, h(x) is either 0 or 1, and it can be inferred from g(x); h(x) is 1 if and only if g(x) is negative.

Example 26.3

$$x_n = 7^5 x_{n-1} \bmod (2^{31} - 1)$$

- ❑ $2^{31}-1 = 2147483647 =$ prime number
- ❑ $7^5 = 16807$ is one of its 534,600,000 primitive roots
- ❑ The product $a x_{n-1}$ can be as large as $16807 \times 2147483647 \approx 1.03 \times 2^{45}$.
- ❑ Need 46-bit integers
 - $a = 16807$
 - $m = 2147483647$
 - $q = m \operatorname{div} a = 2147483647 \operatorname{div} 16807 = 127773$
 - $r = m \bmod a = 2147483647 \bmod 16807 = 2836$
- ❑ For a correct implementation, $x_0 = 1 \Rightarrow x_{10000} = 1,043,618,065$.

Generator Using Integer Arithmetic

```
FUNCTION Random(VAR x:INTEGER) : REAL;
```

```
CONST
```

```
  a = 16807;      (* Multiplier *)  
  m = 2147483647; (* Modulus *)  
  q = 127773;    (* m div a *)  
  r = 2836;      (* m mod a *)
```

```
VAR
```

```
  x_div_q, x_mod_q, x_new: INTEGER;
```

```
BEGIN
```

```
  x_div_q := x DIV q;
```

```
  x_mod_q := x MOD q;
```

```
  x_new := a*x_mod_q - r*x_div_q;
```

```
  IF x_new >= 0 THEN x := x_new ELSE x := x_new + m;
```

```
  x := mod(x_new, m); ← { WHILE x_new < 0 DO x_new := x_new + m;  
                        WHILE x_new >= m DO x_new := x_new - m;  
                        x := x_new;
```

```
  END;
```

Generator Using Real Arithmetic

```
FUNCTION Random(VAR x:DOUBLE) : DOUBLE;
```

```
CONST
```

```
  a = 16807.0D0;      (* Multiplier *)  
  m = 2147483647.0D0; (* Modulus *)  
  q = 127773.0D0;    (* m div a *)  
  r = 2836.0D0;      (* m mod a *)
```

```
VAR
```

```
  x_div_q, x_mod_q, x_new: DOUBLE;
```

```
BEGIN
```

```
  x_div_q := TRUNC(x/q);  
  x_mod_q := x-q*x_div_q;  
  x_new := a*x_mod_q - r*x_div_q;  
  IF x_new >= 0.0D0 THEN x := x_new ELSE x := x_new + m;  
  x := mod(x_new, m);  
  Random := x/m;
```

```
END;
```

Example 26.3 (Cont)

a	16807
m	2147483647
q	127773
r	2836
i	x
0	1
10	2007237709
20	143542612
30	1505795335
40	784558821
50	937186357
60	130060903
70	158374933
80	1654001669
90	1908194298
100	892053144
10000	1043618065
20000	673160914

Homework 26

□ Exercise 26.5 Updated:

Implement the following LCG using Schrage's method to avoid overflow:

$$x_n = 40014x_{n-1} \bmod 2147483563$$

Using a seed of $x_0=1$, determine $x_1, x_{10}, x_{100}, x_{1000}, x_{10000}, x_{20000}$.

Note: In Excel:

$$x_div_q = x \% q$$

$$r^*(x \% q) \neq r * x \% q$$

Tausworthe Generators

- ❑ Need long random numbers for cryptographic applications
- ❑ Generate random sequence of binary digits (0 or 1)
- ❑ Divide the sequence into strings of desired length
- ❑ Proposed by Tausworthe (1965)

$$b_n = c_{q-1}b_{n-1} \oplus c_{q-2}b_{n-2} \oplus c_{q-3}b_{n-3} \oplus \cdots \oplus c_0b_{n-q}$$

Where c_i and b_i are binary variables with values of 0 or 1, and \oplus is the exclusive-or (mod 2 addition) operation.

- ❑ Uses the last q bits of the sequence
 \Rightarrow autoregressive sequence of order q or AR(q).
- ❑ An AR(q) generator can have a maximum period of 2^q-1 .

Tausworthe Generators (Cont)

□ $D =$ delay operator such that $Db(n) = b(n + 1)$

$$D^q b(i - q) = c_{q-1} D^{q-1} b(i - q) + c_{q-2} D^{q-2} b(i - q) + \cdots + c_0 b(i - q) \pmod{2}$$

$$D^q - c_{q-1} D^{q-1} - c_{q-2} D^{q-2} - \cdots - c_0 = 0 \pmod{2}$$

$$D^q + c_{q-1} D^{q-1} + c_{q-2} D^{q-2} + \cdots + c_0 = 0 \pmod{2}$$

□ **Characteristic polynomial:**

$$x^q + c_{q-1} x^{q-1} + c_{q-2} x^{q-2} + \cdots + c_0$$

□ The period is the smallest positive integer n for which $x^n - 1$ is divisible by the characteristic polynomial.

□ The maximum possible period with a polynomial of order q is $2^q - 1$. The polynomials that give this period are called **primitive polynomials**.

Example 26.4

$$x^7 + x^3 + 1$$

- Using D operator in place of x :

$$D^7 b(n) + D^3 b(n) + b(n) = 0 \pmod{2}$$

Or:

$$b_{n+7} + b_{n+3} + b_n = 0 \pmod{2} \quad n = 0, 1, 2, \dots$$

- Using the exclusive-or operator

$$b_{n+7} \oplus b_{n+3} \oplus b_n = 0 \quad n = 0, 1, 2, \dots$$

Or:

$$b_{n+7} = b_{n+3} \oplus b_n \quad n = 0, 1, 2, \dots$$

- Substituting $n-7$ for n :

$$b_n = b_{n-4} \oplus b_{n-7} \quad n = 7, 8, 9, \dots$$

Example 26.4 (Cont)

- Starting with $b_0 = b_1 = \dots = b_6 = 1$:

$$b_7 = b_3 \oplus b_0 = 1 \oplus 1 = 0$$

$$b_8 = b_4 \oplus b_1 = 1 \oplus 1 = 0$$

$$b_9 = b_5 \oplus b_2 = 1 \oplus 1 = 0$$

$$b_{10} = b_6 \oplus b_3 = 1 \oplus 1 = 0$$

$$b_{11} = b_7 \oplus b_4 = 0 \oplus 1 = 1$$

- The complete sequence is:

1111111 0000111 0111100 1011001 0010000 0010001
0011000 1011101 0110110 0000110 0110101 0011100
1111011 0100001 0101011 1110100 1010001 1011100
0111111 1000011 1000000.

- Period = 127 or $2^7 - 1$ bits

\Rightarrow The polynomial $x^7 + x^3 + 1$ is a primitive polynomial.

Linear Feedback Shift Register

$$x^5+x^3+1 \Rightarrow b_n = b_{n-2} \oplus b_{n-5}$$

- This can be easily implemented using shift registers:

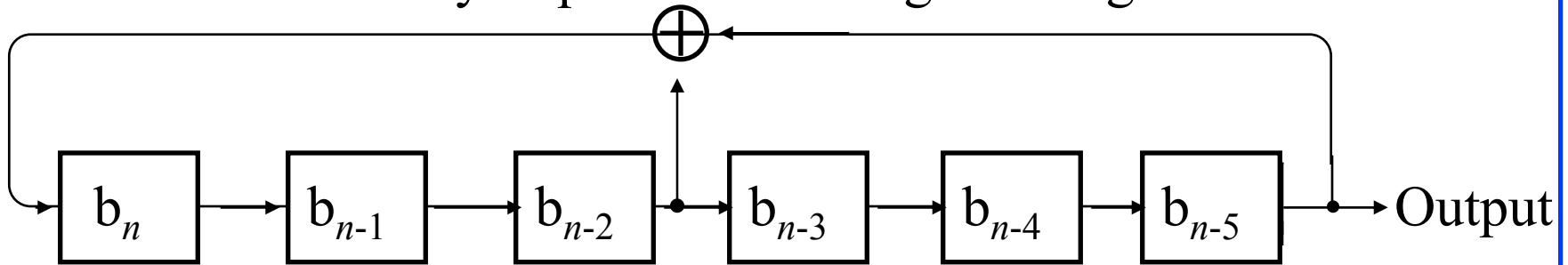

- In general: $b_n = c_{q-1}b_{n-1} \oplus c_{q-2}b_{n-2} \oplus c_{q-3}b_{n-3} \oplus \dots \oplus c_0b_{n-q}$

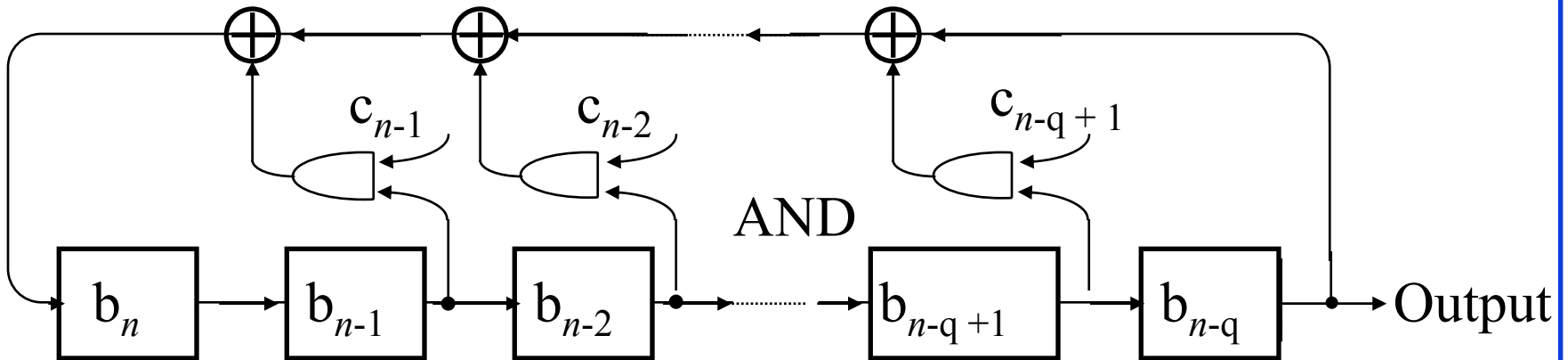

AND gates are not required if c_i 's are known

Generating U(0,1)

- Divide the sequence into successive groups of s bits and use the first l bits of each group as a binary fraction:

$$x_n = 0.b_{sn}b_{sn+1}b_{sn+2}b_{sn+3} \cdots b_{sn+l-1}$$

Or equivalently:
$$x_n = \sum_{j=1}^l 2^{-j} b_{sn+j-1}$$

Here, s is a constant greater than or equal to l and is relatively prime to 2^q-1 .

$s \geq l \Rightarrow x_n$ and x_j for $n \neq j$ have no bits in common

- Relative prime-ness guarantees a full period 2^q-1 for x_n .

Example 26.5

$$b_n = b_{n-4} \oplus b_{n-7}$$

□ The period $2^7-1=127$

□ $l=8, s=8$:

$$x_0 = 0.11111110_2 = 0.99219_{10}$$

$$x_1 = 0.00011101_2 = 0.11328_{10}$$

$$x_2 = 0.11100101_2 = 0.89453_{10}$$

$$x_3 = 0.10010010_2 = 0.29688_{10}$$

$$x_4 = 0.00000100_2 = 0.36328_{10}$$

$$x_5 = 0.01001100_2 = 0.42188_{10}$$

⋮

Disadvantages of Tausworthe Generators

- ❑ The sequence may produce good test results over the complete cycle, it may not have satisfactory local behavior.
- ❑ It performed negatively on the runs up and down test.
- ❑ Although the first-order serial correlation is almost zero, it is suspected that some primitive polynomials may give poor high-order correlations.
- ❑ Not all primitive polynomials are equally good.

Combined Generators

1. Adding random numbers obtained by two or more generators.

$$w_n = (x_n + y_n) \bmod m$$

For example, L'Ecuyer (1986):

$$x_n = 40014x_{n-1} \bmod 2147483563$$

$$y_n = 40692y_{n-1} \bmod 2147483399$$

This would produce:

$$w_n = (x_n - y_n) \bmod 2147483562$$

$$\text{Period} = 2.3 \times 10^{18}$$

Combined Generators (Cont)

Another Example: For 16-bit computers:

$$w_n = 157w_{n-1} \bmod 32363$$

$$x_n = 146x_{n-1} \bmod 31727$$

$$y_n = 142y_{n-1} \bmod 31657$$

Use:

$$v_n = (w_n - x_n + y_n) \bmod 32362$$

This generator has a period of 8.1×10^{12} .

Combined Generators (Cont)

2. Exclusive-or random numbers obtained by two or more generators.
3. Shuffle. Use one sequence as an index to decide which of several numbers generated by the second sequence should be returned.

Combined Generators (Cont)

□ Algorithm M:

- a) Fill an array of size, say, 100.
- b) Generate a new y_n (between 0 and $m-1$)
- c) Index $i = l + 100 y_n / m$
- d) i th element of the array is returned as the next random number
- e) A new value of x_n is generated and stored in the i th location

Survey of Random-Number Generators

- A currently popular multiplicative LCG is:

$$x_n = 7^5 x_{n-1} \bmod (2^{31} - 1)$$

- Used in:
 - SIMPL/I system (IBM 1972),
 - APL system from IBM (Katzan 1971),
 - PRIMOS operating system from Prime Computer (1984), and
 - Scientific library from IMSL (1980)
- $2^{31}-1$ is a prime number and 7^5 is a primitive root of it
⇒ Full period of $2^{31}-2$.
- This generator has been extensively analyzed and shown to be good.
- Its low-order bits are uniformly distributed.

Survey of RNG's (Cont)

- Fishman and Moore (1986)'s exhaustive search of $m=2^{31}-1$:

$$x_n = 48271x_{n-1} \bmod (2^{31} - 1)$$

$$x_n = 69621x_{n-1} \bmod (2^{31} - 1)$$

- SIMSCRIPT II.5 and in DEC-20 FORTRAN:

$$x_n = 630360016x_{n-1} \bmod (2^{31} - 1)$$

Survey of RNG's (Cont)

- ❑ ``RANDU" (IBM 1968): Very popular in the 1960s:

$$x_n = (2^{16} + 3)x_{n-1} \bmod 2^{31}$$

- Modulus and the multiplier were selected primarily to facilitate easy computation.
- Multiplication by $2^{16}+3=65539$ can be easily accomplished by a few shift and add instructions.
- Does not have a full period and has been shown to be flawed in many respects.
- Does not have good randomness properties (Knuth, p 173).
- Triplets lie on a total of 15 planes
⇒ Unsatisfactory three-distributivity
- Like all LCGs with $m=2^k$, the lower order bits of this generator have a small period. RANDU is no longer used

Survey of RNG's (Cont)

- ❑ Analog of RANDU for 16-bit microprocessors:

$$x_n = (2^8 + 3)x_{n-1} \bmod (2^{15})$$

- This generator shares all known problems of RANDU
- Period = only a few thousand numbers
⇒ not suitable for any serious simulation study

- ❑ University of Sheffield Pascal system for Prime Computers:

$$x_n = 16807x_{n-1} \bmod 2^{31}$$

- $16807 \neq 8i \pm 3 \Rightarrow$ Does not have the maximum possible period of $2^{31}-2$.
- Used with a shuffle technique in the subroutine UNIFORM of the SAS statistical package

Survey of RNG's (cont)

- ❑ SIMULA on UNIVAC uses the following generator:

$$x_n = 5^{13} x_{n-1} \bmod 2^{35}$$

- Has maximum possible period of 2^{33} , Park and Miller (1988) claim that it does not have good randomness properties.

- ❑ The UNIX operating system:

$$x_n = (1103515245x_{n-1} + 12345) \bmod 2^{32}$$

- Like all LCGs with $m=2^k$, the binary representation of x_n 's has a cyclic bit pattern

Seed Selection

- ❑ **Multi-stream simulations:** Need more than one random stream
 - Single queue \Rightarrow Two streams
= Random arrival and random service times
- 1. **Do not use zero.** Fine for mixed LCGs.
But multiplicative LCG or a Tausworthe LCG will stick at zero.
- 2. **Avoid even values.** For multiplicative LCG with modulus $m=2^k$, the seed should be odd. Better to avoid generators that have too many conditions on seed values or whose performance (period and randomness) depends upon the seed value.
- 3. **Do not subdivide one stream.**

Seed Selection (Cont)

4. Do not generate successive seeds: u_1 to generate inter-arrival times, u_2 to generate service time \Rightarrow Strong correlation
5. Use non-overlapping streams.
Overlap \Rightarrow Correlation, e.g., Same seed \Rightarrow same stream
6. Reuse seeds in successive replications.
7. Do not use random seeds: Such as the time of day.
Can't reproduce. Can't guaranteed non-overlap.
8. Select $\{u_0, u_{100,000}, u_{200,000}, \dots\}$

$$x_n = a^n x_0 + \frac{c(a^n - 1)}{a - 1} \text{ mod } m$$

Table of Seeds

$$x_n = 7^5 x_{n-1} \bmod (2^{31} - 1)$$

$x_{100000i}$	$x_{100000(i+1)}$	$x_{100000(i+2)}$	$x_{100000(i+3)}$
1	46,831,694	1,841,581,359	1,193,163,244
727,633,698	933,588,178	804,159,733	1,671,059,989
1,061,288,424	1,961,692,154	1,227,283,347	1,171,034,773
276,090,261	1,066,728,069	209,208,115	554,590,007
721,958,466	1,371,272,478	675,466,456	1,095,462,486
1,808,217,256	2,095,021,727	1,769,349,045	904,914,315
373,135,028	717,419,739	881,155,353	1,489,529,863
1,521,138,112	298,370,230	1,140,279,430	1,335,826,707
706,178,559	110,356,601	884,434,366	962,338,209
1,341,315,363	709,314,158	591,449,447	431,918,286
851,767,375	606,179,079	1,500,869,201	1,434,868,289
263,032,577	753,643,799	202,794,285	715,851,524

Myths About Random-Number Generation

1. *A complex set of operations leads to random results.* It is better to use simple operations that can be analytically evaluated for randomness.
2. *A single test, such as the chi-square test, is sufficient to test the goodness of a random-number generator.* The sequence $0, 1, 2, \dots, m-1$ will pass the chi-square test with a perfect score, but will fail the run test \Rightarrow Use as many tests as possible.
3. *Random numbers are unpredictable.* Easy to compute the parameters, a , c , and m from a few numbers \Rightarrow LCGs are unsuitable for cryptographic applications

Myths (Cont)

4. *Some seeds are better than others.* May be true for some.

$$x_n = (9806x_{n-1} + 1) \bmod (2^{17} - 1)$$

- Works correctly for all seeds except $x_0 = 37911$
- Stuck at $x_n = 37911$ forever
- Such generators should be avoided.
- Any *nonzero* seed in the valid range should produce an equally good sequence.
- For some, the seed should be odd.
- Generators whose period or randomness depends upon the seed should not be used, since an unsuspecting user may not remember to follow all the guidelines.

Myths (Cont)

5. *Accurate implementation is not important.*

- RNGs must be implemented without any overflow or truncation For example,

$$x_n = 1103515245x_{n-1} + 12345 \text{ mod } 2^{31}$$

- In FORTRAN:

$$x_n = (1103515245x_{n-1} + 12345).AND.X'7FFFFFFF'$$

- The AND operation is used to clear the sign bit
- Straightforward multiplication above will produce overflow.

6. *Bits of successive words generated by a random-number generator are equally randomly distributed.*

- If an algorithm produces l -bit wide random numbers, the randomness is guaranteed only when all l bits are used to form successive random numbers.

Example 26.7

$$x_n = (25173x_{n-1}) \bmod 2^{16}$$

Notice that:

- a) Bit 1 (the least significant bit) is always 1.
- b) Bit 2 is always 0.
- c) Bit 3 alternates between 1 and 0, thus, it has a cycle of length 2.
- d) Bit 4 follows a cycle (0110) of length 4.
- e) Bit 5 follows a cycle (11010010) of length 8.

n	x_n	
	Decimal	Binary
1	25,173	01100010 01010101
2	12,345	00110000 00111001
3	54,509	11010100 11101101
4	27,825	01101100 10110001
5	55,493	11011000 11000101
6	25,449	01100011 01101001
7	13,277	00110011 11011101
8	53,857	11010010 01100001
9	64,565	11111100 00110101
10	1945	00000111 10011001
11	6093	00010111 11001101
12	24,849	01100001 00010001
13	48,293	10111100 10100101

Example 26.7 (Cont)

- ❑ The least significant bit is either always 0 or always 1.
- ❑ The l th bit has a period at most 2^l . ($l=1$ is the least significant bit)
- ❑ For all mixed LCGs with $m=2^k$:
 - The l th bit has a period at most 2^l .
 - In general, the high-order bits are more randomly distributed than the low-order bits.
⇒ Better to take the high-order l bits than the low-order l bits.

Summary

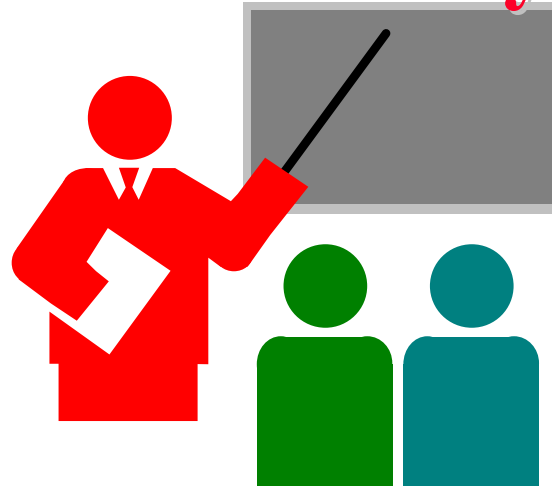

- ❑ Pseudo-random numbers are used in simulation for repeatability, non-overlapping sequences, long cycle
- ❑ It is important to implement PRNGs in integer arithmetic without overflow => Schrage's method
- ❑ For multi-stream simulations, it is important to select seeds that result in non-overlapping sequences
- ❑ Two or more generators can be combined for longer cycles
- ❑ Bits of random numbers may not be random