

Router Virtualization Protocols

Raj Jain

Washington University in Saint Louis

Saint Louis, MO 63130

Jain@cse.wustl.edu

These slides and audio/video recordings of this class lecture are at:

<http://www.cse.wustl.edu/~jain/cse570-18/>



1. Hot Standby Router Protocol (HSRP)
2. Virtual Router Redundancy Protocol (VRRP)
3. Virtual Routing and Forwarding (VRF)
4. Virtual Device Context (VDC)

Router Virtualization

- ❑ Multiple routers act as one router
 - Hot Standby Router Protocol (HSRP) and Virtual Router Redundancy Protocol (VRRP)
 - Virtual Routing and Forwarding (VRF)
- ❑ One router acts as multiple routers
 - Virtual Device Context (VDC)

Hot Standby Router Protocol (HSRP)

- ❑ Problem: What to do if default gateway fails?
- ❑ Solution: Multiple default gateways act as one virtual default gateway.
- ❑ All routers have a real-IP (RIP) and a virtual IP (VIP). Clients send to VIP
- ❑ Only active/master router forwards packets.
- ❑ Standby routers keep track of the active/master router. Elect a new active router if the current active router fails.
- ❑ **Hot Standby Router Protocol (HSRP)** is described in RFC 2281.

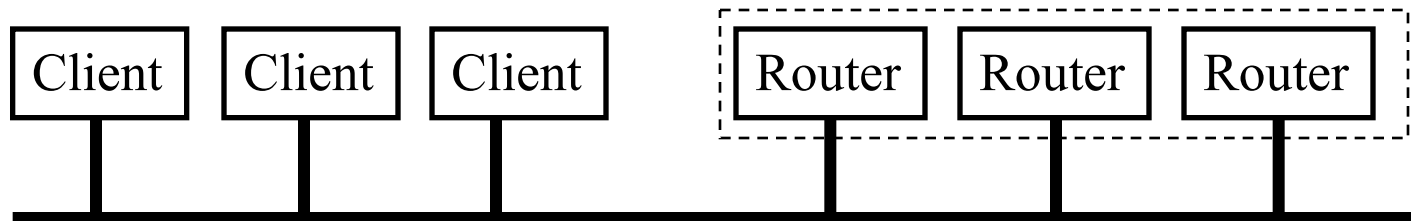

Virtual Router Redundancy Protocol (VRRP)

- ❑ HSRP is Cisco proprietary.
- ❑ **Virtual Router Redundancy Protocol (VRRP)** described in RFC 5798 is the IETF standard version and is similar.
- ❑ Each VRRP is limited to a single subnet.
Does not advertise routes beyond that subnet.
Does not affect routing tables.

Ref: http://en.wikipedia.org/wiki/Virtual_Router_Redundancy_Protocol

Routing Information Base (RIB)

- ❑ RIB: Routing table constructed by various routing protocols, such as, Open Shortest Path First (OSPF), Border Gateway Protocol (BGP), Routing Information Protocol (RIP)
- ❑ For each destination prefix, RIB entries point to which router the packet should be sent to. The router may or may not be adjacent (particularly for BGP).
- ❑ Example: R_1 's RIB will show R_4 as the path to 128.28.23.0/8
- ❑ RIB preparation is a control plane activity.
- ❑ Control plane is implemented using general purpose processors.

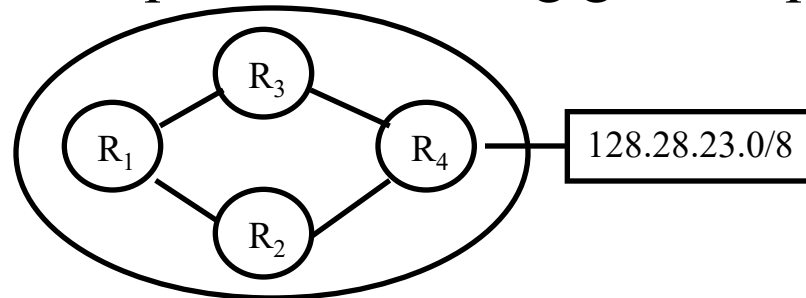

Forwarding Information Base (FIB)

- ❑ FIB: The table used to forward packets. It lists the *next hop* for each destination prefix.
- ❑ FIB is used in data plane and hence it has to be fast.
- ❑ Data plane is implemented using special purpose network processors.
- ❑ FIB is constructed from RIB. When the entries are copied, the next hop is resolved, outgoing interfaces are computed, and multiple entries are created if there are multiple paths to the destination prefix.
- ❑ Example: R_1 's FIB will have 2 entries for 128.28.23.0/8 via R_2 and R_3 .

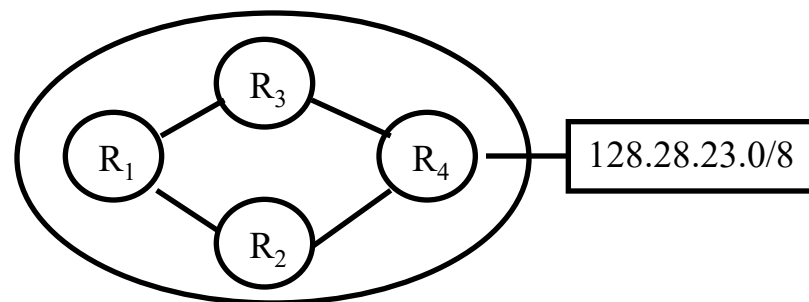

Virtual Routing and Forwarding (VRF)

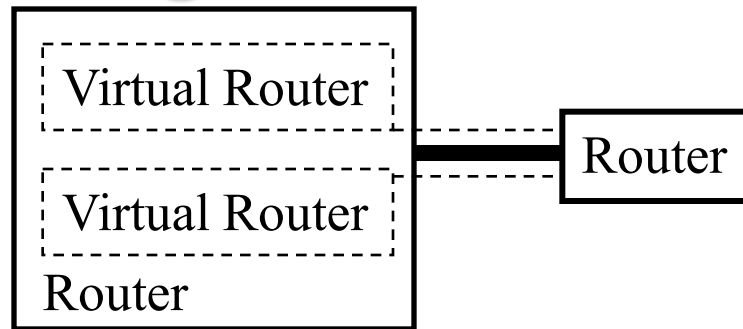

- ❑ Allows multiple virtual routers within a single physical router.
 - Each virtual router has its own routing table, network interfaces, and routing protocols
 - Each virtual router has its own forwarding information base (FIB) and routing information base (RIB)
 - VRFs exchange routing (e.g., OSPF) information with other virtual and physical routers.
 - Users of one VRF cannot communicate with users of another VRFs unless explicitly configured.

Ref: http://en.wikipedia.org/wiki/Virtual_Routing_and_Forwarding

Washington University in St. Louis

<http://www.cse.wustl.edu/~jain/cse570-18/>

©2018 Raj Jain

VRF (Cont)

- ❑ Originally designed for carrier networks to allow enterprises to have a virtual WAN using MPLS.
- ❑ Customer edge (CE) routers forward to provider edge (PE) routers. Entry PE routers encapsulate packets and forward to exit-PE. Exit PE decapsulate and give it to CE.
- ❑ PE routers use virtual routing table containing only routes to the customer's virtual PE's.
Core routers in the carrier's network are unchanged.

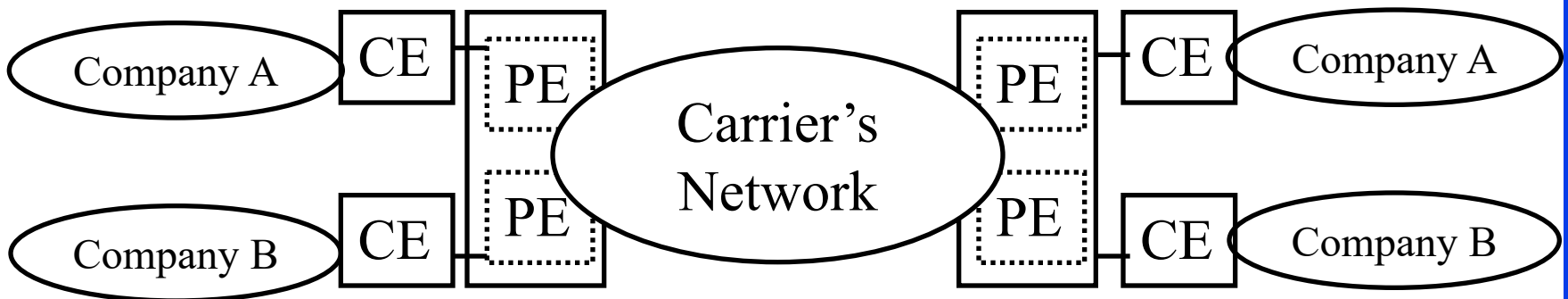

VRF Tunneling

- ❑ VRFs connected over multiple hops require tunneling. GRE and MPLS are two tunneling techniques used in WANs.
- ❑ VRF Lite = w/o MPLS = hop-by-hop
- ❑ VRF now used in data centers. Multiple VRFs can share an interface using VLANs.

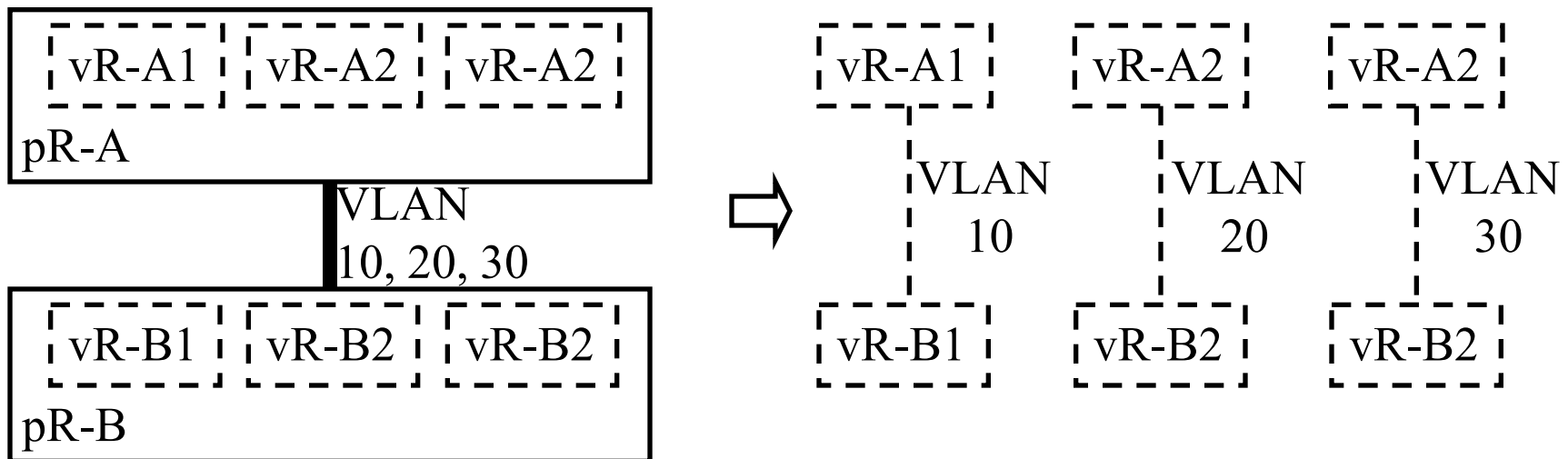

VRF Example

□ Data Center Segmentation:

Physical
Topology

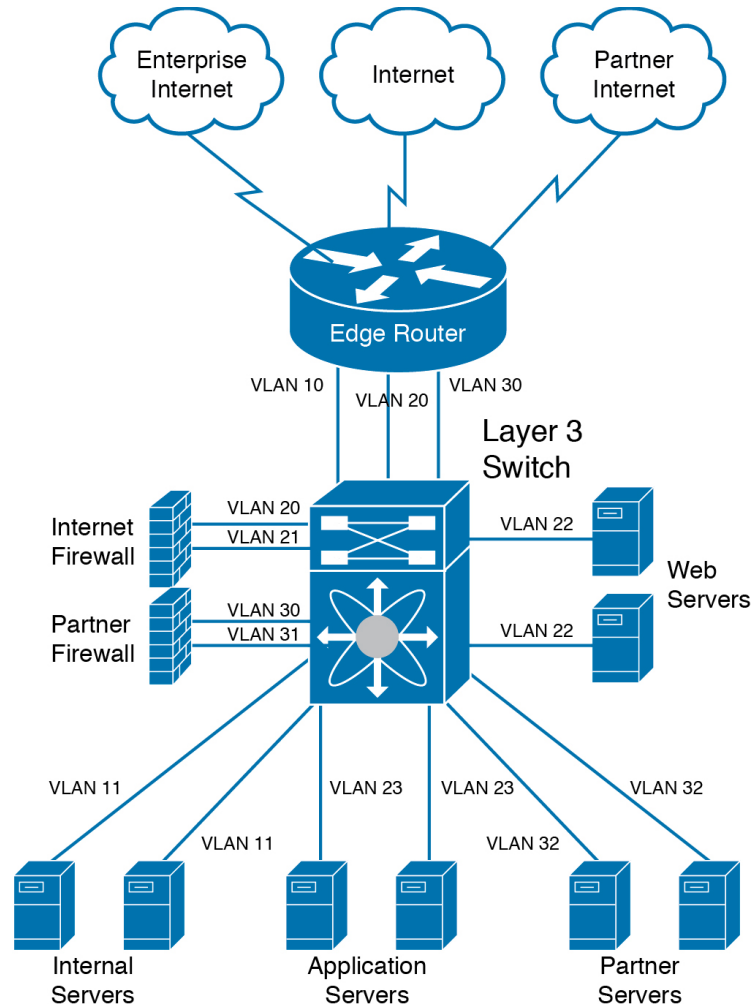

Source: Santana 2014

VRF Example (Cont)

Logical
Topology

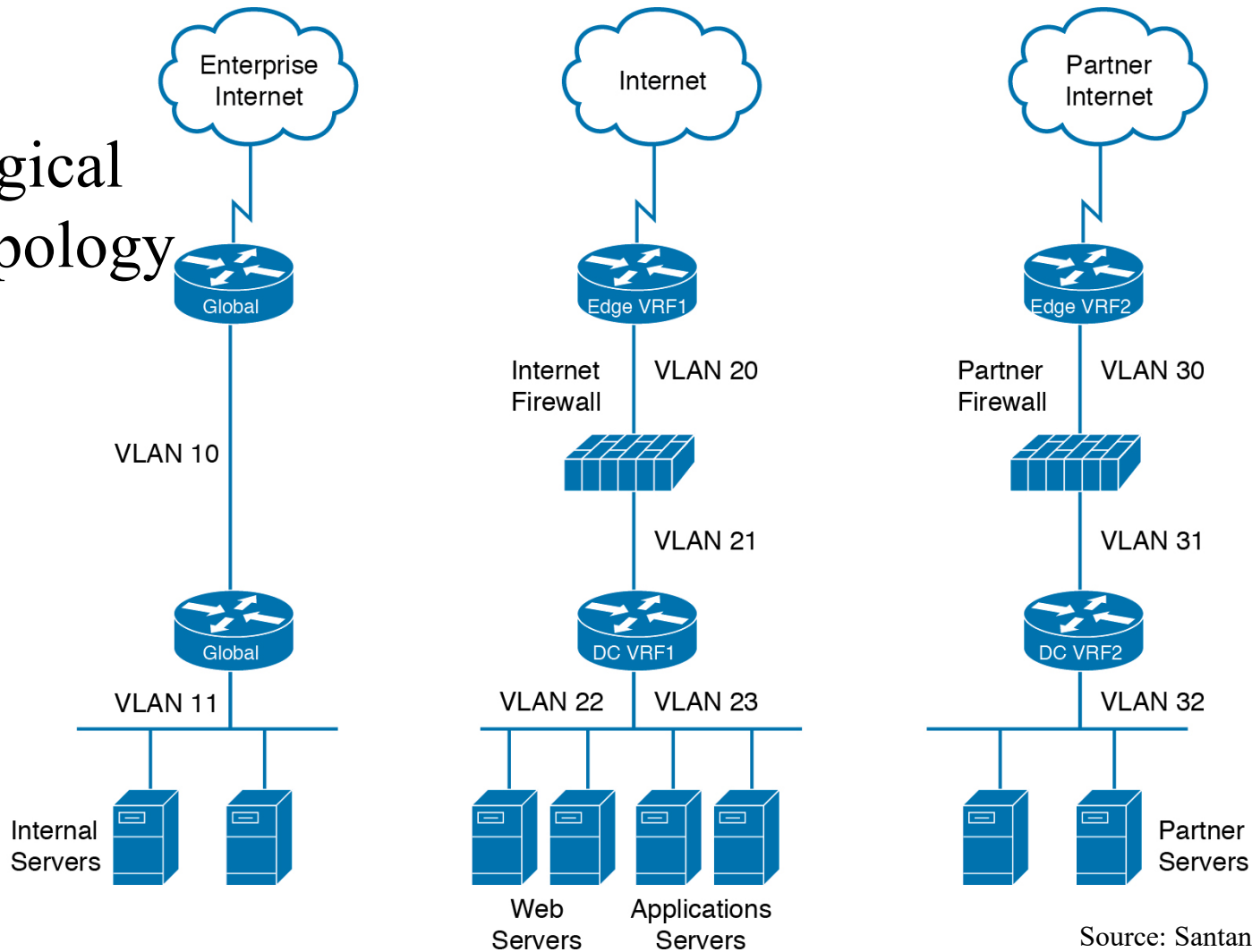

Source: Santana 2014

Virtual Device Context (VDC)

- ❑ Cisco proprietary concept.
- ❑ Combines virtual application delivery controllers (e.g., virtual firewalls) concepts to Ethernet switching.
- ❑ A VDC includes VRFs and associated VLANs.
- ❑ A physical L3 switch can be partitioned into multiple VDCs

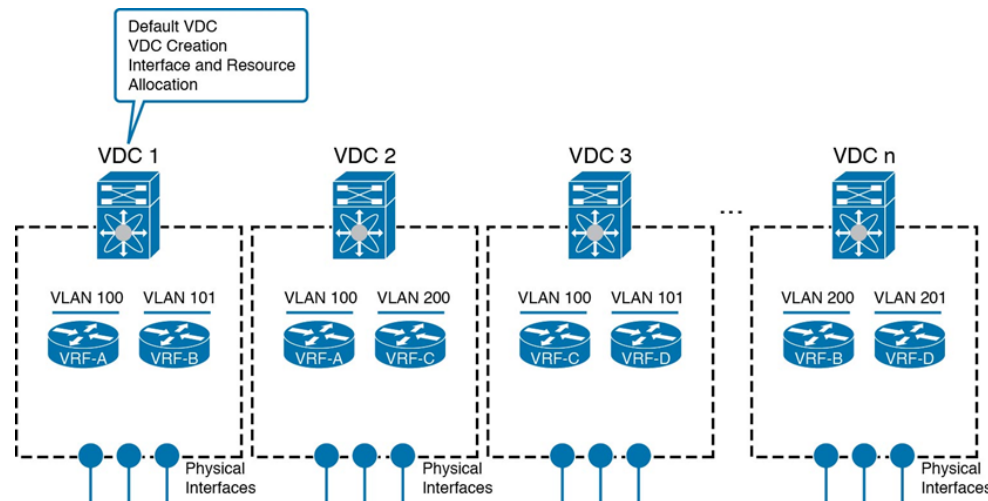

Ref: G. Santana, "Datacenter Virtualization Fundamentals," Cisco Press, 2014, ISBN: 1587143240

VDC (Cont)

- ❑ A VDC has its own virtual data, control, and management plane.
 - Virtual Data Plane: Isolation between various VDCs
 - Virtual Control Plane: Own protocols, RIBs, ...
 - Virtual Management Plane: Managed by non-trusting entities. Different VDCs can have VRFs with the same name.
- ❑ Each VDC has its own physical interfaces
 - ⇒ A port can not belong to multiple VDCs.
 - ⇒ Allows different VDCs to have overlapping VLAN IDs
- ❑ Large switches can have several hundred interfaces. These switches can be partitioned using VDCs.

VDC Example

- ❑ One switch can be used as aggregation switch and core router
- ❑ Example only. Not a common case.

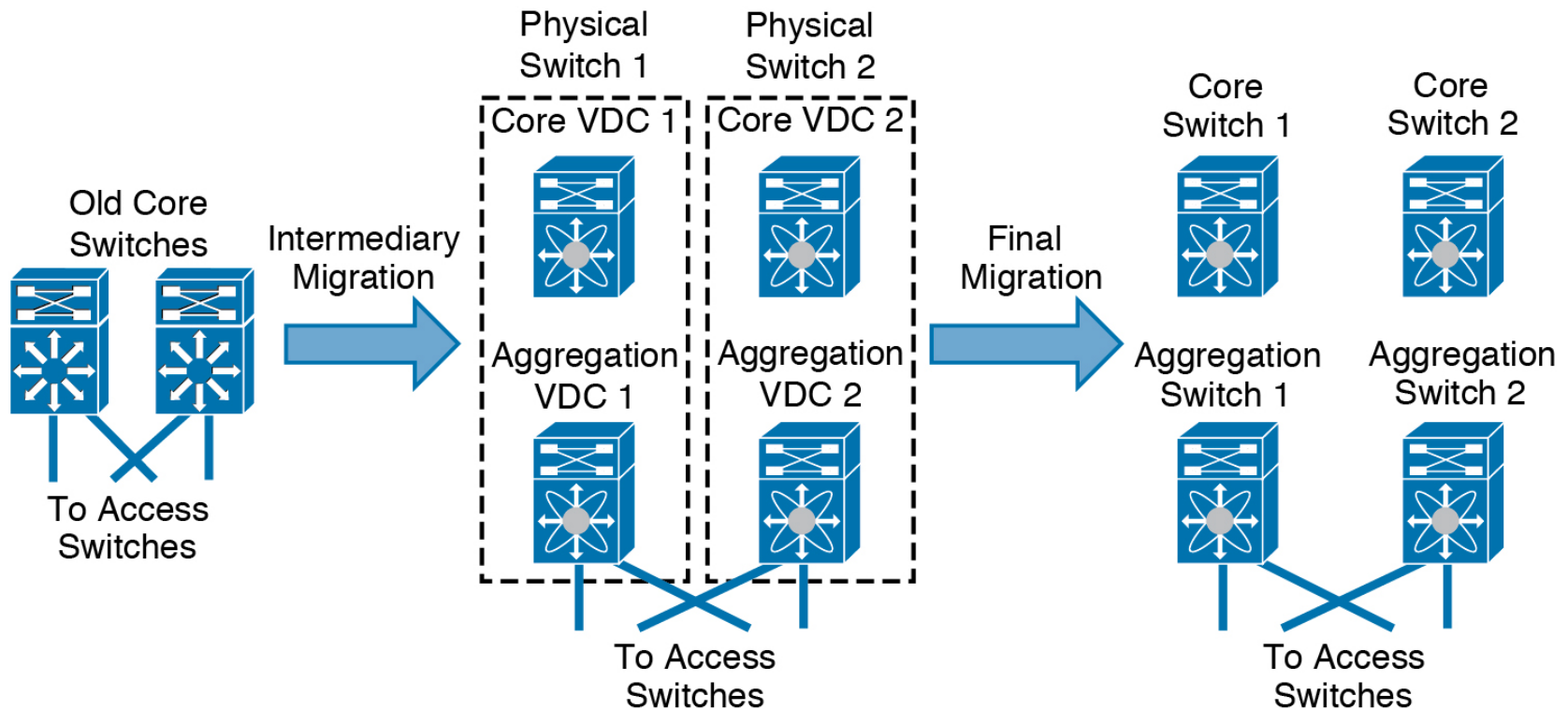

Source: Santana 2014

Summary

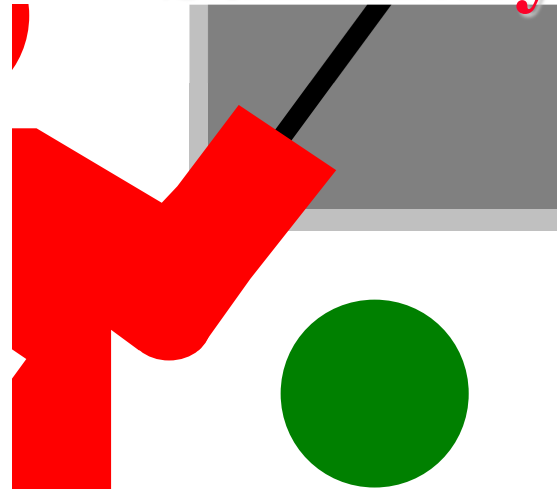

- ❑ HSRP allows multiple routers to act as default gateway by all of them having the same VIP.
- ❑ VRRP is the IETF standard version of Cisco proprietary HSRP.
- ❑ VRF allows partitioning a router for multiple tenants.
- ❑ VDC allows partitioning a switch or application delivery controllers.

Reading List

- ❑ G. Santana, “Datacenter Virtualization Fundamentals,” Cisco Press, 2014, ISBN: 1587143240 (Safari Book)
- ❑ Javvin Technologies, "Network Protocols Handbook," Javvin Press, 2007, 380 pp., Chapter 5 and 55, ISBN:0974094528 (Safari book)

Wikipedia Links

- ❑ http://en.wikipedia.org/wiki/Hot_Standby_Router_Protocol
- ❑ http://en.wikipedia.org/wiki/Virtual_Router_Redundancy_Protocol
- ❑ http://en.wikipedia.org/wiki/Forwarding_information_base
- ❑ http://en.wikipedia.org/wiki/Routing_Information_Base
- ❑ http://en.wikipedia.org/wiki/Virtual_Routing_and_Forwarding

Acronyms

- ❑ BGP Border Gateway Protocol
- ❑ CE Customer edge
- ❑ FEX Fabric Extension
- ❑ FIB Forwarding Information Base
- ❑ GRE Generic Routing Encapsulation
- ❑ HSRP Hot Standby Router Protocol
- ❑ ID Identifier
- ❑ IETF Internet Engineering Task Force
- ❑ IP Internet Protocol
- ❑ MPLS Multi Protocol Label Switching
- ❑ OSPF Open Shortest Path First
- ❑ PE Provider Edge
- ❑ RFC Request for Comments
- ❑ RIB Routing Information Base
- ❑ RIP Routing Information Protocol
- ❑ VBE Virtual Bridge Port Extension

Acronyms (Cont)

- ❑ VDC Virtual Device Context
- ❑ VEB Virtual Edge Bridge
- ❑ VIP Virtual IP Address
- ❑ VLAN Virtual Local Area Network
- ❑ vPC Virtual Port Channels
- ❑ VRF Virtual Routing and Forwarding
- ❑ VRRP Virtual Router Redundancy Protocol
- ❑ VSS Virtual Switching System
- ❑ WAN Wide Area Network

Scan This to Download These Slides



Raj Jain

<http://rajjain.com>

Related Modules



CSE567M: Computer Systems Analysis (Spring 2013),

https://www.youtube.com/playlist?list=PLjGG94etKypJEKjNAa1n_1X0bWWNyZcof

CSE473S: Introduction to Computer Networks (Fall 2011),

https://www.youtube.com/playlist?list=PLjGG94etKypJWOSPMh8Azcg5e_10TiDw



Wireless and Mobile Networking (Spring 2016),

https://www.youtube.com/playlist?list=PLjGG94etKypKeb0nzyN9tSs_HCd5c4wXF

CSE571S: Network Security (Fall 2011),

<https://www.youtube.com/playlist?list=PLjGG94etKypKvzfVtutHcPFJXumyyg93u>



Video Podcasts of Prof. Raj Jain's Lectures,

<https://www.youtube.com/channel/UCN4-5wzNP9-ruOzQMs-8NUw>