

Data Center Networks: Virtual Bridging



Raj Jain
Washington University in Saint Louis
Saint Louis, MO 63130
Jain@cse.wustl.edu

These slides and audio/video recordings of this class lecture are at:
<http://www.cse.wustl.edu/~jain/cse570-21/>

Student Questions



1. Virtual Bridges to connect virtual machines
2. IEEE Virtual Edge Bridging Standard
3. Single Root I/O Virtualization (SR-IOV)
4. Aggregating Bridges and Links: VSS and vPC
5. Bridges with massive number of ports: VBE

Student Questions

Virtualization

“Virtualization means that Applications can use a resource without any concern for where it resides, what the technical interface is, how it has been implemented, which platform it uses, and how much of it is available.”

-Rick F. Van der Lans

in Data Virtualization for Business Intelligence Systems

Student Questions

What is Virtual?

- ❑ If you can see it and it is there \Rightarrow Its real
- ❑ If you can't see it but it is there \Rightarrow It's transparent
- ❑ If you can see it and it is not there \Rightarrow It's virtual
- ❑ If you can not see it and it is not there \Rightarrow It's gone

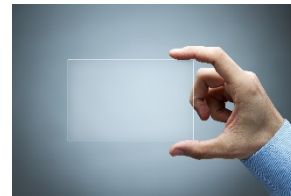

Student Questions

Ref: Cisco Live, "What you make possible," <https://www.alcatron.net/Cisco%20Live%202013%20Melbourne/Cisco%20Live%20Content/Data%20Centre%20And%20Virtualisation/BRKVIR-2931%20%20End-to-End%20Data%20Centre%20Virtualisation.pdf>

5 Reasons to Virtualize

1. Sharing: Break up a large resource
Large Capacity or high-speed
E.g., Servers
2. Isolation: Protection from other tenants
E.g., Virtual Private Network
3. Aggregating: Combine many resources into one, e.g., storage
4. Dynamics: Fast allocation, Change/Mobility, load balancing, e.g., virtual machines
5. Ease of Management \Rightarrow Easy distribution, deployment, testing

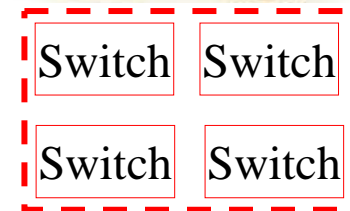
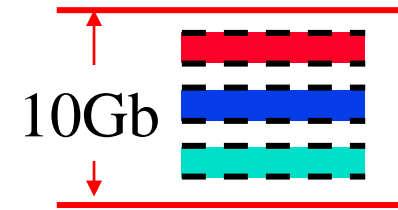

Student Questions

- Are there still any privacy issues when using virtualization?

*Security issues
sometimes if the firewall
is weak.*

Advantages of Virtualization

- ❑ Minimize hardware costs (CapEx)
Multiple virtual servers on one physical hardware
- ❑ Easily move VMs to other data centers
 - Provide disaster recovery. Hardware maintenance.
 - Follow the sun (active users) or follow the moon (cheap power)
- ❑ Consolidate idle workloads. Usage is bursty and asynchronous.
Increase device utilization
- ❑ Conserve power
Free up unused physical resources
- ❑ Easier automation (Lower OpEx)
Simplified provisioning/administration of hardware and software
- ❑ Scalability and Flexibility: Multiple operating systems



Ref: http://en.wikipedia.org/wiki/Platform_virtualization

Ref: K. Hess, A. Newman, "Practical Virtualization Solutions: Virtualization from the Trenches," Prentice Hall, 2009,

ISBN:0137142978

Washington University in St. Louis

<http://www.cse.wustl.edu/~jain/cse570-21/>

©2021 Raj Jain

Student Questions

- ❑ Is it really easy to move VM ? What if the hardware system is different?

They don't use Macs. All hardware is interoperable.

Virtualization in Computing

❑ Storage:

- Virtual Memory \Rightarrow L1, L2, L3, ... \Rightarrow Recursive
- Virtual CDs, Virtual Disks (RAID), Cloud storage

❑ Computing:

- Virtual Desktop \Rightarrow Virtual Server \Rightarrow Virtual Datacenter
- Thin Client \Rightarrow VMs \Rightarrow Cloud

❑ Networking: Plumbing of computing

- Virtual Channels, Virtual LANs, Virtual Private Networks



Student Questions

- ❑ What is the difference between visual networking computing and cloud computing since visual networking belong to cloud.

Visual Networking = Social networking using Video

Server Virtualization Concepts

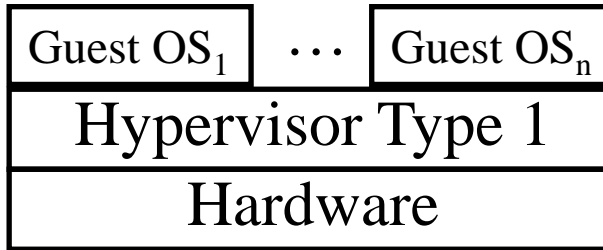
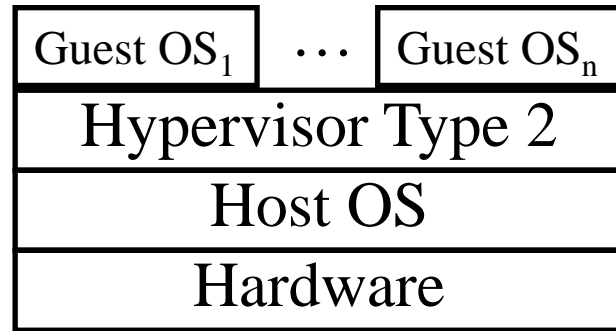

- ❑ Host OS: Runs on the bare metal
- ❑ Guest OS: Runs on the host OS, e.g., Windows 7 on Win 10
- ❑ Hypervisor: Software to support multiple virtual machines
 - Type 1: Runs on bare metal, e.g., Xen, VMware ESXi
 - Type 2: Runs on a host OS, e.g., MS Virtual PC
 - Type 0: Both 1 and 2, e.g., Linux Kernel-based Virtual Machine (KVM)

Student Questions

- ❑ Would it be accurate to say Virtualbox would be Type 2 Hypervisor but Cloud would more likely use Type 1?

Yes.

Network Virtualization

1. Network virtualization allows tenants to form an overlay network in a multi-tenant network such that tenant can control:
 1. Connectivity layer: Tenant network can be L2 while the provider is L3 and vice versa
 2. Addresses: MAC addresses and IP addresses
 3. Network Partitions: VLANs and Subnets
 4. Node Location: Move nodes freely
2. Network virtualization allows providers to serve a large number of tenants without worrying about:
 1. Internal addresses used in client networks
 2. Number of client nodes
 3. Location of individual client nodes
 4. Number and values of client partitions (VLANs and Subnets)
3. Network could be a single physical interface, a single physical machine, a data center, a metro, ... or the global Internet.
4. Provider could be a system owner, an enterprise, a cloud provider, or a carrier.

Student Questions

- Is wireless network able to use Network Virtualization?

Yes.

Levels of Network Virtualization

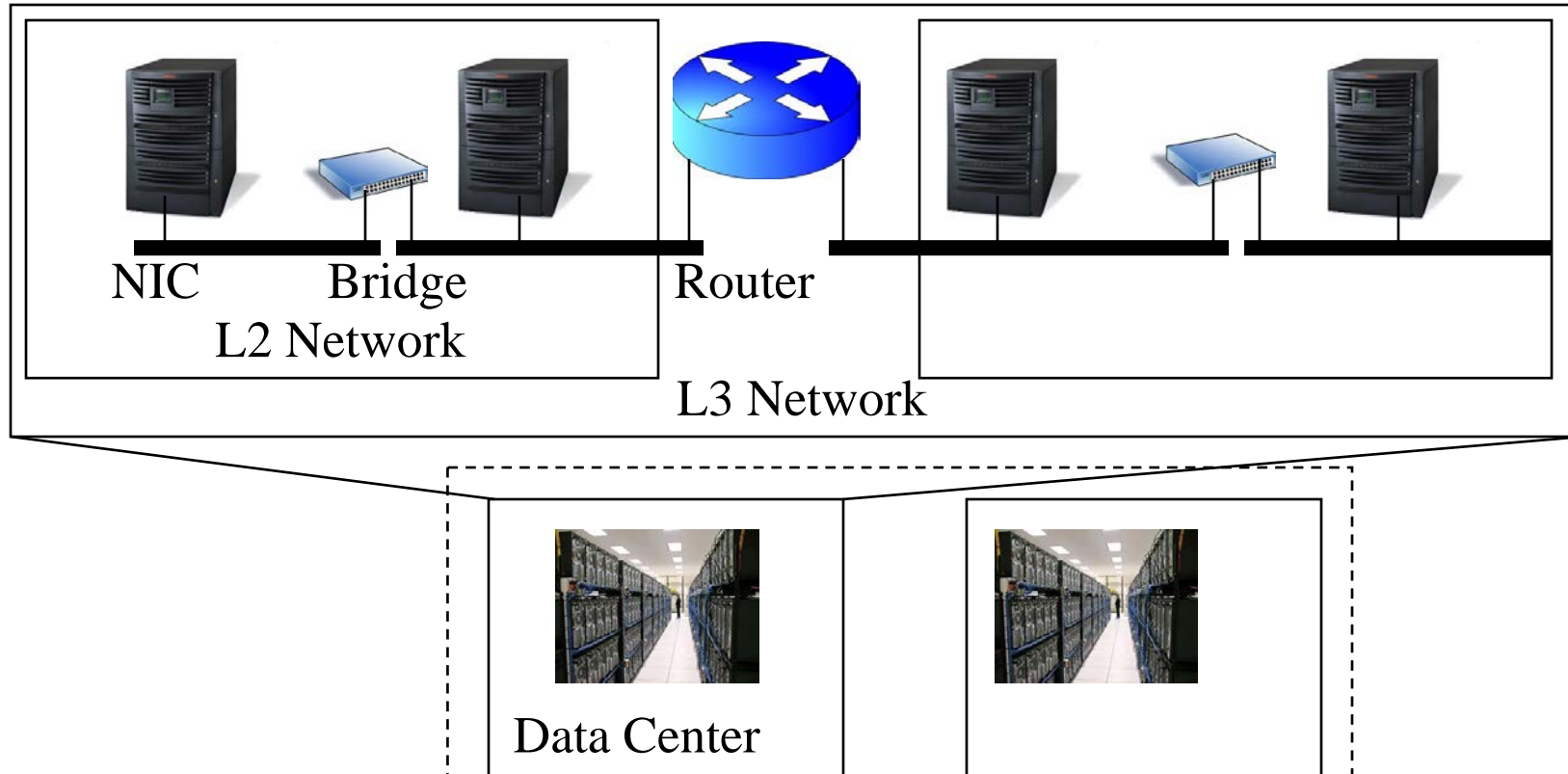

Student Questions

- ❑ Networks consist of: **Host Interface** - L2 Links - **L2 Bridges** - **L2 Networks** - L3 Links - L3 Routers - L3 Networks – **Data Centers** – **Global Internet**.
- ❑ Each of these needs to be virtualized

Network Virtualization Techniques

Entity	Partitioning	Aggregation/Extension/Interconnection**
NIC	SR-IOV	MR-IOV
Switch	VEB, VEPA	VSS, VBE, DVS, FEX
L2 Link	VLANs	LACP, Virtual PortChannels
L2 Network using L2	VLAN	PB (Q-in-Q), PBB (MAC-in-MAC), PBB-TE, Access-EPL, EVPL, EVP-Tree, EVPLAN
L2 Network using L3	NVO3, VXLAN, NVGRE, STT	MPLS, VPLS, A-VPLS, H-VPLS, PWoMPLS, PWoGRE, OTV, TRILL, LISP, L2TPv3, EVPN, PBB-EVPN
Router	VDCs, VRF	VRRP, HSRP
L3 Network using L1		GMPLS, SONET
L3 Network using L3*	MPLS, GRE, PW, IPsec	MPLS, T-MPLS, MPLS-TP, GRE, PW, IPsec
Application	ADCs	Load Balancers

*All L2/L3 technologies for L2 Network partitioning and aggregation can also be used for L3 network partitioning and aggregation, respectively, by simply putting L3 packets in L2 payloads.

**The aggregation technologies can also be seen as partitioning technologies from the provider point of view.

Student Questions

vSwitch

- ❑ **Problem:** Multiple VMs on a server need to use one physical network interface card (pNIC)
- ❑ **Solution:** Hypervisor creates multiple vNICs connected via a virtual switch (vSwitch)
- ❑ pNIC is controlled by hypervisor and not by any individual VM
- ❑ **Notation:** From now on prefixes **p** and **v** refer to physical and virtual, respectively. For VMs only, we use upper case V.

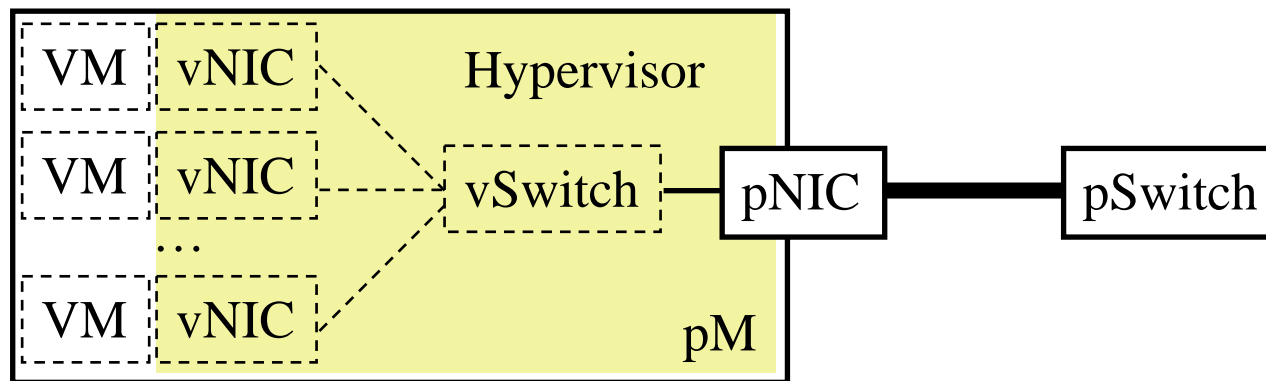

Ref: G. Santana, "Datacenter Virtualization Fundamentals," Cisco Press, 2014, ISBN: 1587143240

Washington University in St. Louis

<http://www.cse.wustl.edu/~jain/cse570-21/>

©2021 Raj Jain

Student Questions

Virtual Bridging

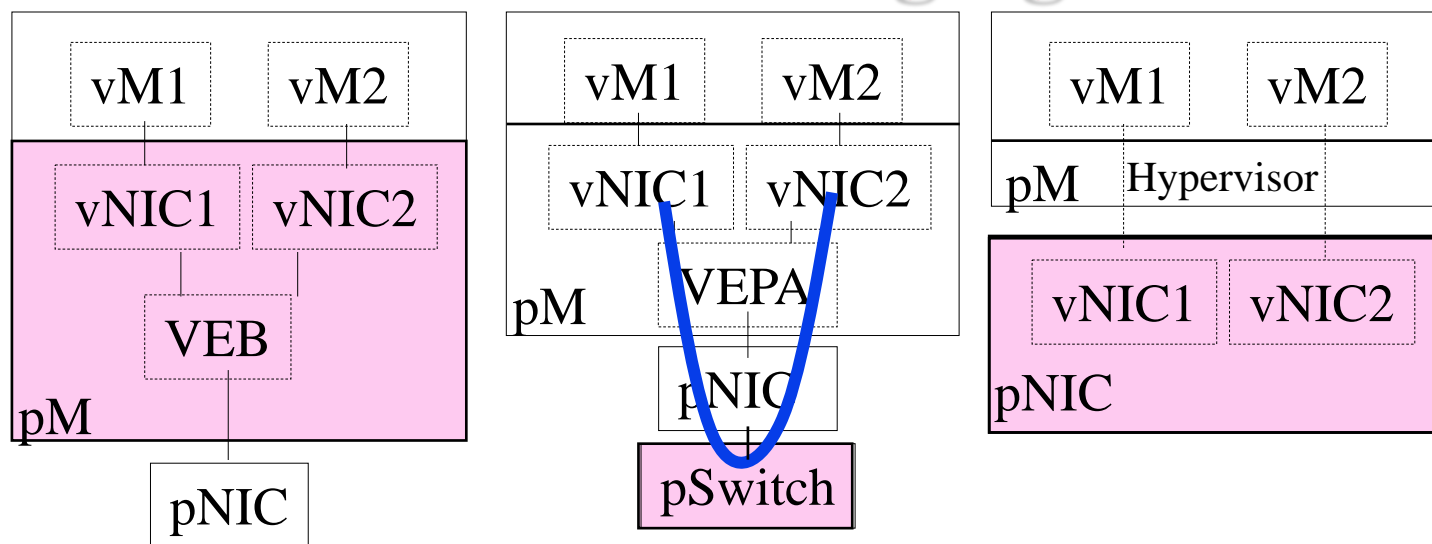

Where should most of the tenant isolation take place?

1. VM vendors: S/W NICs in Hypervisor w Virtual Edge Bridge (**VEB**): **802.1Qbg** (overhead, not ext manageable, not all features)
2. Switch Vendors: Switch provides virtual channels for inter-VM Communications using virtual Ethernet port aggregator (**VEPA**): **802.1Qbg** (s/w upgrade)
3. NIC Vendors: NIC provides virtual ports using Single-Route I/O virtualization (**SR-IOV**) on PCI bus

Student Questions

- ❑ Can you explain slide 13 again?

Sure.

- ❑ What Layer is SR-IOV?

L1

- ❑ In the left figure), can the VEB be replaced by VEPA?

Yes, as shown in the middle picture.

Virtual Edge Bridge

- ❑ IEEE 802.1Qbg-2012 standard for vSwitch
- ❑ Two modes for vSwitches to handle *local* VM-to-VM traffic:
 - **Virtual Edge Bridge (VEB):** Switch internally.
 - **Virtual Ethernet Port Aggregator (VEPA):** Switch externally
- ❑ VEB
 - could be in a hypervisor or network interface card
 - may learn or may be configured with the MAC addresses
 - VEB may participate in spanning tree or may be configured\
 - Advantage: No need for the external switch in some cases

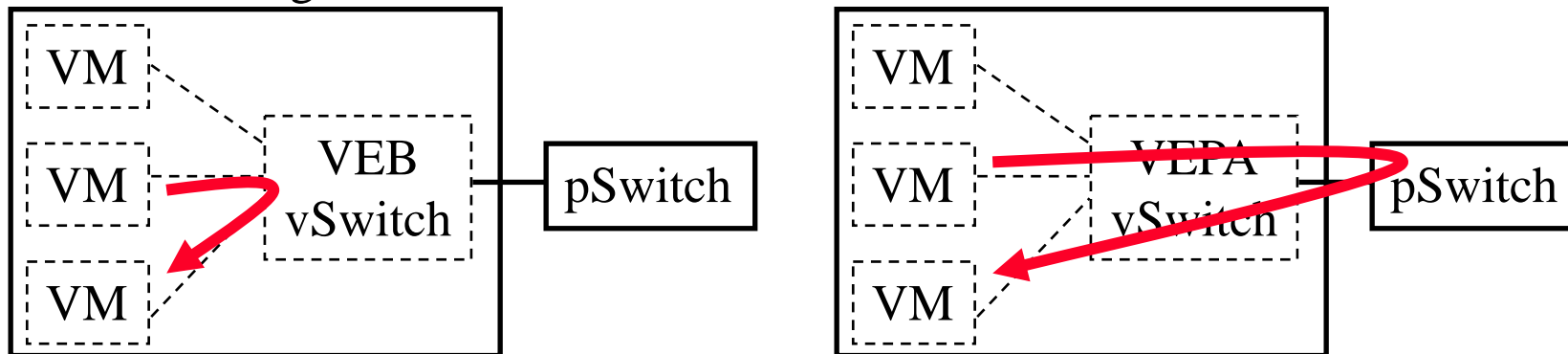

Student Questions

- ❑ If the VEBs learn or are configured with MAC addresses, does that mean the VMs that they control have virtual MAC that is understandable to the outside world? Or only the physical server has the MAC still but some techniques (e.g. port forwarding) is used to let VM talk to outside?

All virtual bridges learn like their physical counter part.

- ❑ For the VEB, since it uses the vSwitch, why a pSwitch is still there in the picture?
pSwitch is for communication with the outside world.

❑ Does VEPA have any advantage over VEB?
Two points of view. That is why IEEE selected both.

- ❑ how to determine which to use? VEB vs VEPA? based on what?

You don't have to manufacturers decide it for you.

Virtual Ethernet Port Aggregator (VEPA)

- ❑ VEPA simply relays all traffic to an external bridge
- ❑ External bridge forwards the traffic. Called “*Hairpin Mode.*”
Returns local VM traffic back to VEPA
Note: Legacy bridges do not allow traffic to be sent back to the incoming port within the same VLAN
- ❑ **VEPA Advantages:**
 - Visibility: External bridge can see VM to VM traffic.
 - Policy Enforcement: Better. E.g., firewall
 - Performance: Simpler vSwitch ⇒ Less load on CPU
 - Management: Easier
- ❑ Both VEB and VEPA can be implemented on the same NIC in the same server and can be cascaded.

Student Questions

PCIe

- ❑ Peripheral Component Interconnect (PCI)
Used in computers for I/O – storage, video, network cards
- ❑ Designed by PCI Special Interest Group (PCI-SIG)
- ❑ **PCI Express (PCIe)**: Serial point-to-point interconnect with multiple lanes, 4 pins per lane. X1=1 Lane, x32=32 lanes
2 GB/s/lane.
- ❑ **Root complex** is the head of connection to CPU
- ❑ **Physical Function (PF)**: Ethernet, Fibre Channel, Video, ...
- ❑ A PCIe card can provide multiple **virtual functions (VFs)** of the same type as PF, e.g., one 10Gbps pNIC = 2× 5Gbps vNICs

Student Questions

Ref: R. Emerick, "PCI Express IO Virtualization Overview," SNIA Education, 2012,

http://www.snia.org/sites/default/files/RonEmerick_PCI_Express_IO_Virtualization.pdf (Excellent)

Washington University in St. Louis

<http://www.cse.wustl.edu/~jain/cse570-21/>

©2021 Raj Jain

Single Root I/O Virtualization (SR-IOV)

- ❑ After configuration by hypervisor, VFs allow direct VM access without hypervisor overhead
- ❑ Single Root \Rightarrow Single hardware domain \Rightarrow In one Server

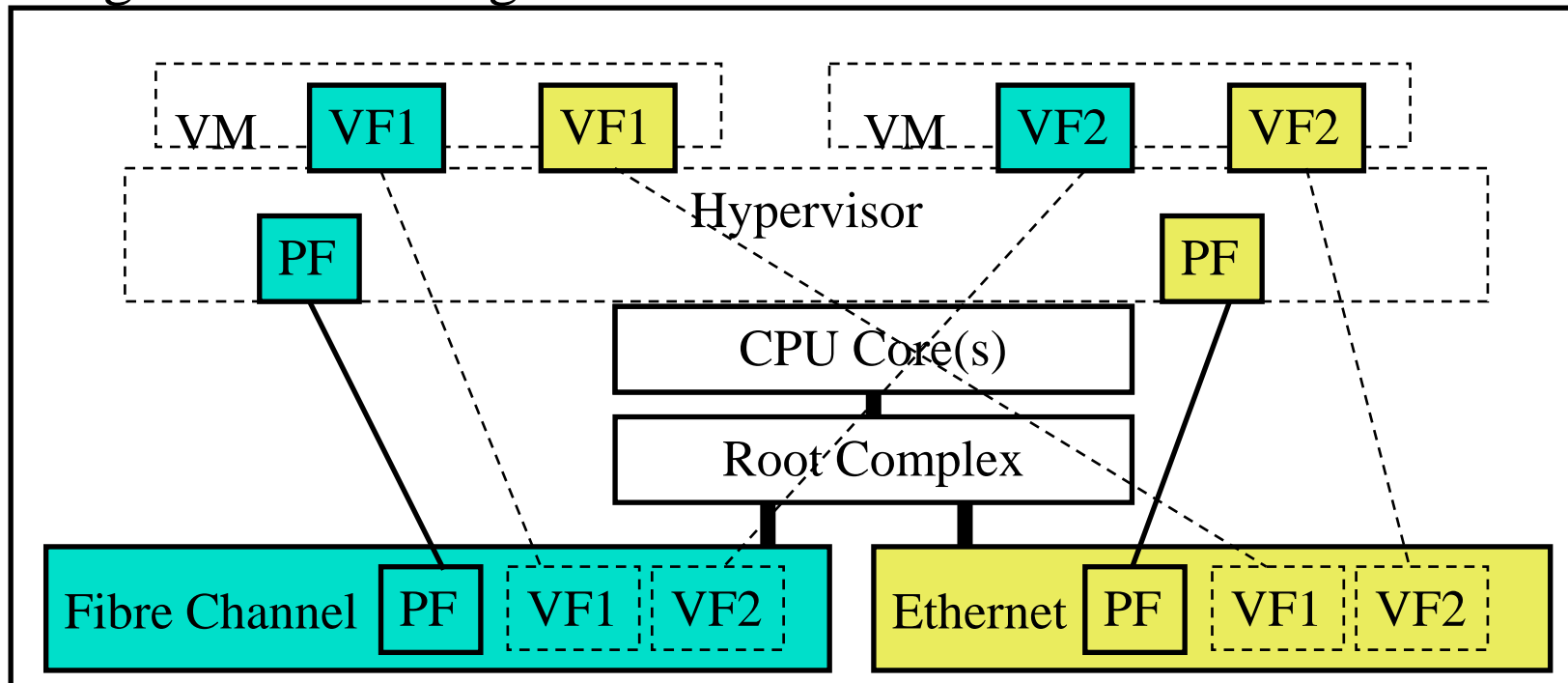

Student Questions

- ❑ It said "without overhead". Why the configuration by hypervisor is not an overhead?

No extra software like VEB and VEPA.

Multi-Root IOV

- ❑ Multiple external PCIe devices accessible via a switch
 - Move PCIe adapter out of the server into a switching fabric
 - Allows adapters to serve many physical servers
 - Used with rack mounted or blade servers
- ❑ Fewer adapters → Less cooling. No adapters → Thinner servers

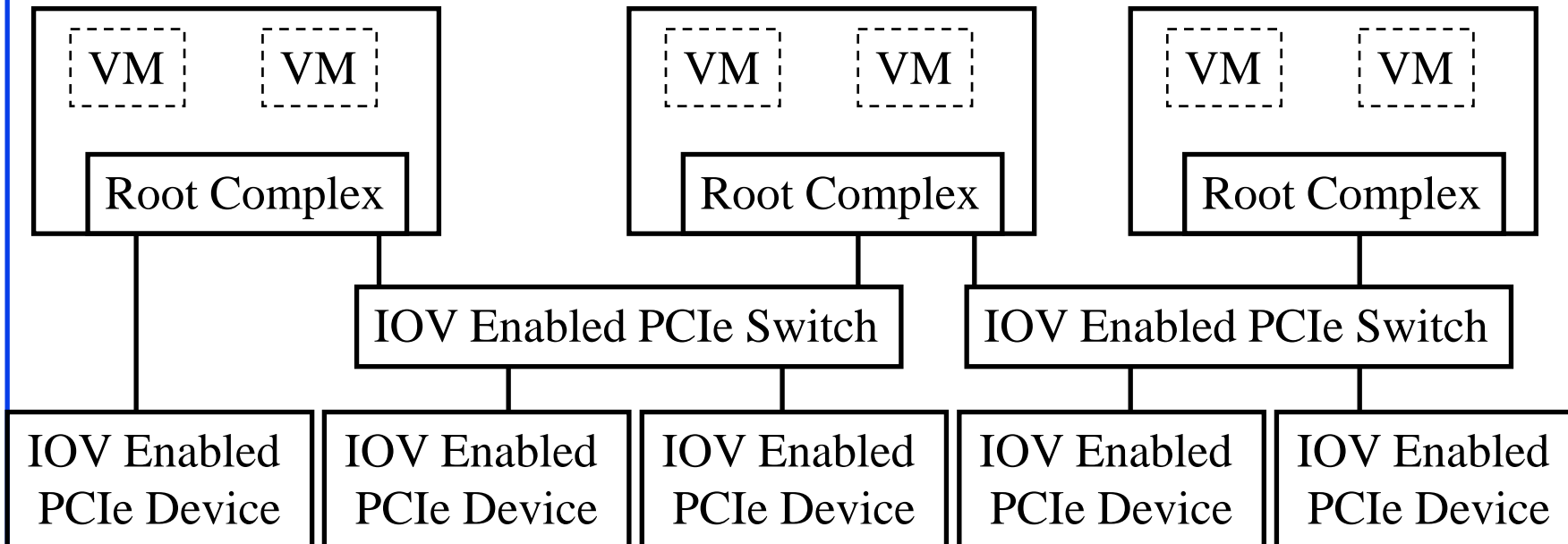

Student Questions

Combining Bridges

❑ Problem:

- Number of VMs is growing very fast
- Need switches with very large number of ports
- Easy to manage one bridge than 100 10-port bridges
- How to make very large switches ~1000 ports?

❑ Solutions: Multiple pswitches to form a single switch

1. Distributed Virtual Switch (DVS)
2. Virtual Switching System (VSS)
3. Virtual PortChannels (vPC)
4. Fabric Extension (FEX)
5. Virtual Bridge Port Extension (VBE)

Student Questions

- ❑ Which of these solutions is the most commonly used and the best?

All proprietary. VBE is standard and coming in.

Distributed Virtual Switch (DVS)

- ❑ VMware idea to solve the scalability issue
- ❑ A centralized DVS controller manages vSwitches on many physical hosts
- ❑ DVS decouples the control and data plane of the switch so that each VM has a virtual data plane managed by a centralized control plane
- ❑ Appears like a single distributed virtual switch
- ❑ Allows simultaneous creation of port groups on multiple pMs
- ❑ Provides an API so that other networking vendors can manage vSwitches and vNICs

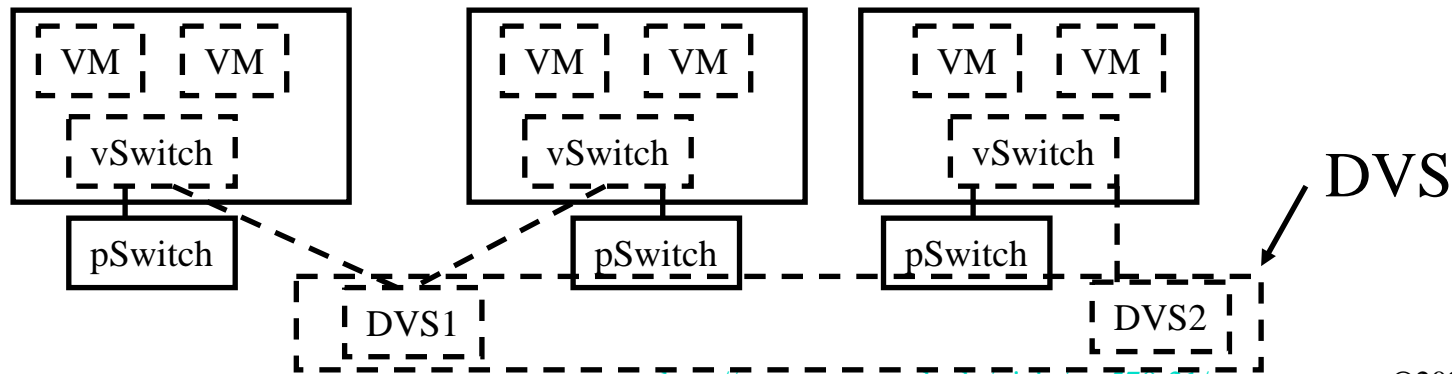

Student Questions

- ❑ How does DVS alleviate the pressure on the physical switches in terms of the port demand? What is the role of the physical switches compared to the DVS in this configuration?

SDN (TBD) can control both DVS and physical switches.

- ❑ DVS controls vSwitches or pSwitches?
vSwitches.

Virtual Switch System (VSS)

- ❑ Allows two physical switches to appear as one
- ❑ Although VSS is a Cisco proprietary name, several vendors implement similar technologies. E.g., Virtual Switch Bonding by Enterasys.
- ❑ Implemented in Firmware → No degradation in performance
- ❑ Only one control plane is active. Data-plane capacity is doubled.
- ❑ Both switches are kept in sync to enable inter-chassis stateful switchover and non-stop forwarding in case of failure

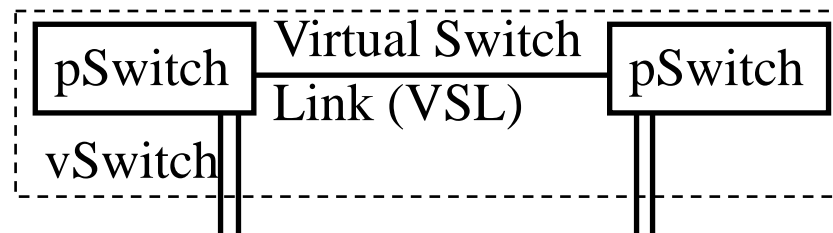

Student Questions

- ❑ What is the different or similarity between DVS and VSS?
- ❑ VMware vs Cisco
- ❑ if both switches forward data traffic then they are both active? no standby! correct?

Yes.

- ❑ By stateful switchover do you mean no loss?

Yes.

- ❑ Why do you need a virtual switch system? Can't we just use one big switch?

One large physical switch can cause too many failures.

- ❑ If only one control plane is active, will there be an overload situation?

Control plane is used infrequently. All the activity is on the data plane.

Virtual PortChannel (vPC)

- ❑ **PortChannel**: Cisco name for aggregated link
- ❑ **Virtual PortChannel**: A link formed by aggregating links to multiple physical switches acting as a virtual switch
- ❑ The combined switch is called “**vPC Domain**”
- ❑ Each member of the vPC domain is called “**vPC peer**”.
- ❑ vPC peer link is used to synchronize state and to forward traffic between the peers. No address learning on the peer link.
- ❑ All learned address tables are kept synchronized among peers. One peer learns an address \Rightarrow Sends it to every one else.

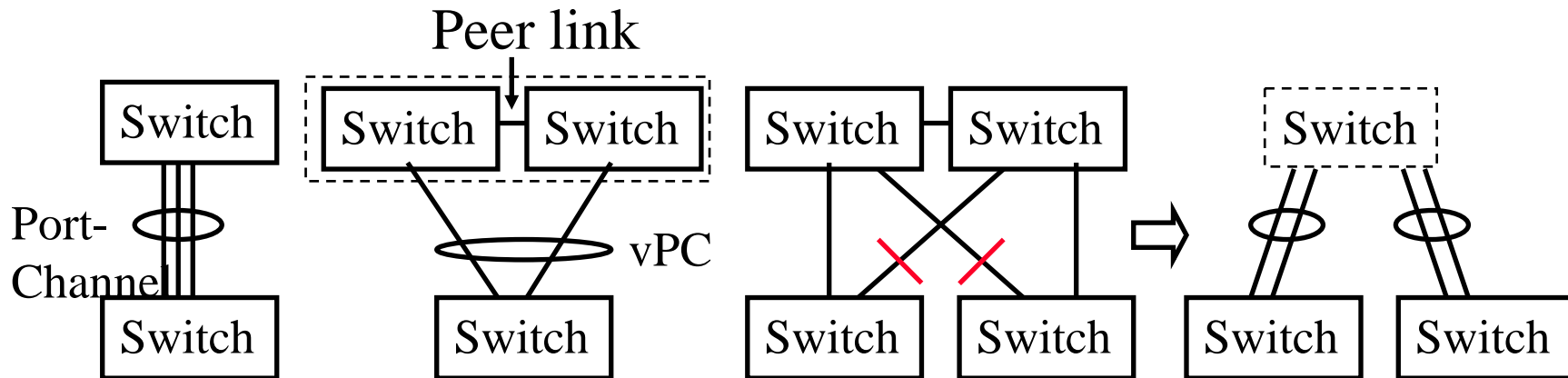

Student Questions

- ❑ Can we have multiple layers of vPC?

Yes.

- ❑ Should all vPC peer switches be identical or not?

No. They must be able to share the control plane

\Rightarrow *Same Manufacturer*

- ❑ How will switch respond if vPC peer link is disconnected?

They will act as individual link

\Rightarrow *No link aggregation*

- ❑ How is vPC different from VSS?

vPC is for channels (links) while VSS is for switches

- ❑ How does vPC domain deals with internal and external broadcast and multicast?

Every one acts as if there is only one switch on the top.

- ❑ In the third figure why the links are marked in red?

- ❑ Do we still use the Dijkstra's path for the spanning tree?

*We **NEVER** used Dijkstra in STP.*

Virtual Port Channel (vPC)

- ❑ Allows aggregation of links going to different switches
→ STP does not block links → All capacity used
- ❑ Unlike VSS, maintains two independent control planes
- ❑ Independent control plane → In-service upgrade
Software in one of the two switches can be upgraded without service interruption
- ❑ Falls back to STP → Used only in small domains
- ❑ vPC is Cisco proprietary. But other vendors have similar technologies. E.g., Split Multi-link Trunking (SMLT) by Nortel or “Multi-Chassis Link Aggregation (MC-LAG)” by Alcatel-Lucent.
- ❑ Standardized in RFC 7275 as “Multi-Chassis LACP”

Student Questions

- ❑ Why can other companies imitate Cisco in many technologies? Is there no patent protection?

Independent research.

- ❑ Since the address tables will be synchronized eventually, why have all switch in vPC domain maintain their individual control plane instead of having a global one?

Address tables are not synchronized unless part of the same virtual switch.

- ❑ Will there ever be data race (e.g. a switch is about to send others an update address, but another switch used the old one before receiving it)?

Using old info is allowed. A few packet will get lost.

Fabric Extenders

- ❑ Fabric Extenders (FEX) consists of ports that are managed by a remote parent switch
- ❑ 12 Fabric extenders, each with 48 host ports, connected to a parent switch via four 16 Gbps interfaces to a parent switch provide a virtual switch with 576 host ports
⇒ **Chassis Virtualization**
- ❑ All software updates/management, forwarding/control plane is managed centrally by the parent switch.
- ❑ A FEX can have an active and a standby parent.

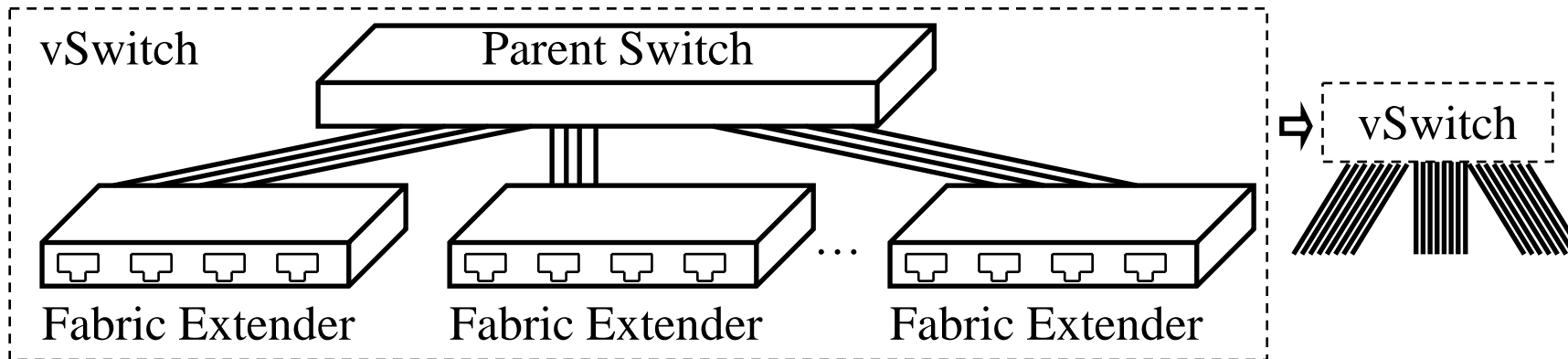

Ref: P. Beck, et al., "IBM and Cisco: Together for a World Class Data Center," IBM Red Book, 2013, 654 pp., ISBN: 0-7384-3842-1, <http://www.redbooks.ibm.com/redbooks/pdfs/sg248105.pdf>

Washington University in St. Louis

<http://www.cse.wustl.edu/~jain/cse570-21/>

©2021 Raj Jain

Student Questions

- ❑ How does a parent switch tell others I have these ports? I mean, let others know the available ports.

All switches handshake when they come up and periodically. It is called the "Hello" message. LACP.

- ❑ You said in the video we have 48 1Gbps coming in and 4 10 Gbps going out (so there is a little overbooking), but why does the slide show 4-16 10 Gbps? Is that a typo or does it mean anything?

Typo. Corrected.

- ❑ Are numbers like "10Gbps" and "48 host ports" an example or a standard?

Examples.

- ❑ What is a standby parent? is it for protection incase main parent fails?

Yes. For protection.

- ❑ Are the fabric extenders active or passive devices?

Minimal electronics for diagnostics. Otherwise can be passive.

- ❑ What layer devices are they?

L2.

FEX Topology Example

- ❑ All hosts are dual homed to FEX
⇒ Two FEX per rack
- ❑ Both FEX are dual homed to two parents
⇒ Two virtual access switches
- ❑ Virtual Access switches are dual homed to aggregation switches.
- ❑ Using vPCs, all links can be active.

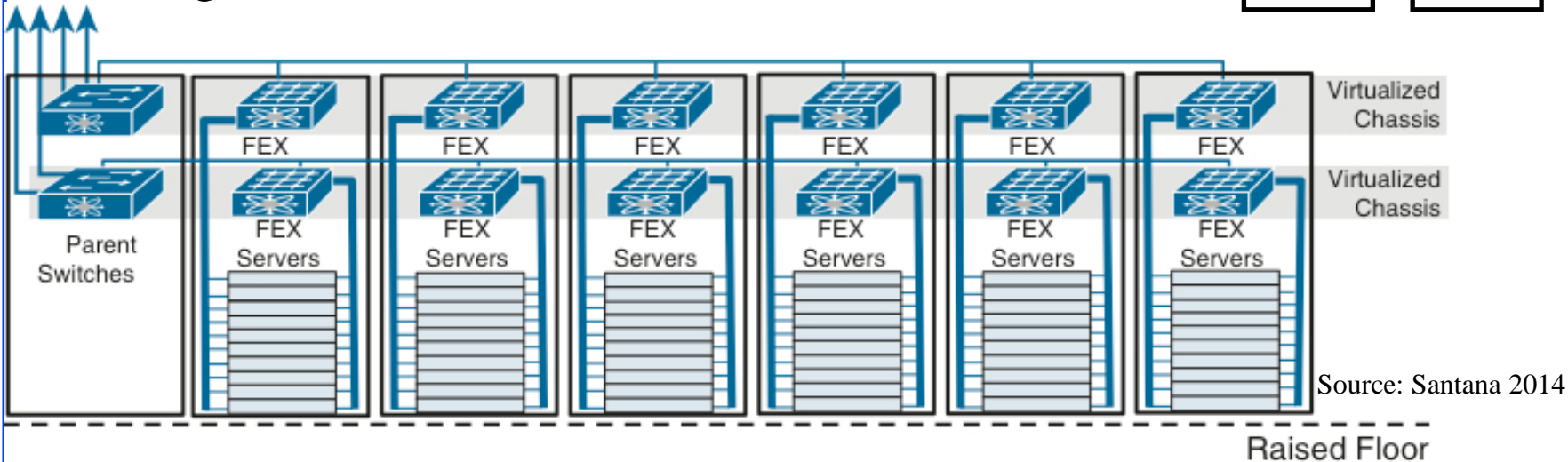
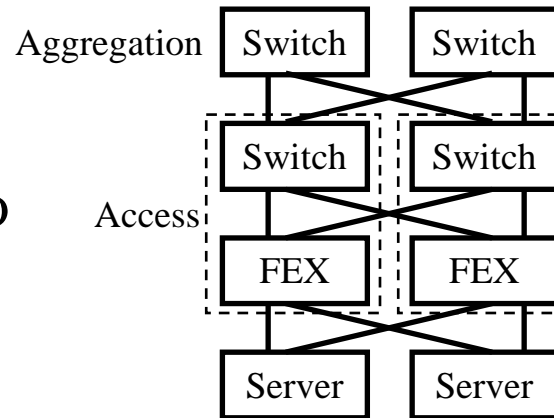

Student Questions

Virtual Bridge Port Extension (VBE)

- ❑ IEEE 802.1BR-2012 standard for fabric extender functions
- ❑ Specifies how to form an extended bridge consisting of a controlling bridge and Bridge Port Extenders
- ❑ Extenders can be cascaded.
- ❑ Some extenders may be in a vSwitch in a server hypervisor.
- ❑ All traffic is relayed by the controlling bridge
⇒ Extended bridge is a bridge.

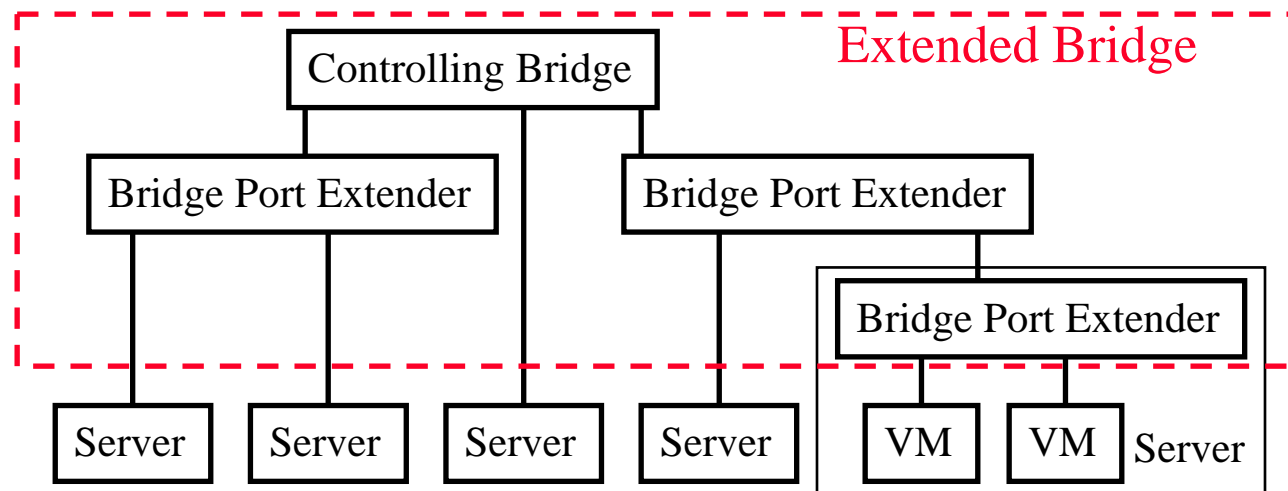

Student Questions

- ❑ Both bridge extenders and servers can connect to controlling bridge. So in controlling bridge's view, are servers and bridge port extenders the same?

No. They are treated differently.

- ❑ Is controlling bridge a dedicated machine or just a bridge extender that being programmed as a controlling bridge?

Dedicated machine.

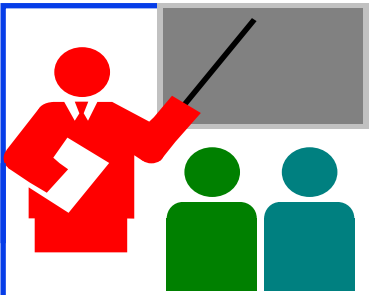

Summary

1. Network virtualization includes virtualization of NICs, Bridges, Routers, and L2 networks.
2. Virtual Edge Bridge (VEB) vSwitches switch internally while Virtual Ethernet Port Aggregator (VEPA) vSwitches switch externally.
3. SR-IOV technology allows multiple virtual NICs via PCI and avoids the need for internal vSwitch.
4. VSS allows multiple switches to appear as one logical switch vPortChannels allow links to multiple switches appear as one.
5. Fabric Extension and Virtual Bridge Extension (VBE) allows creating switches with a large number of ports using port extenders (which may be vSwitches)

Student Questions

Reading List

- ❑ G. Santana, “Datacenter Virtualization Fundamentals,” Cisco Press, 2014, ISBN: 1587143240 (Safari Book)
- ❑ H. Shah, “Management Standards for Edge Virtual Bridging (EVB) and Network Port Profiles,” Nov 2010, <http://www.ieee802.org/1/files/public/docs2011/bg-shah-dmtf-evbportprofile-overview-0311.pdf>

Student Questions

References

- ❑ Intel, “PCI-SIG SR-IOV Primer,” Jan 2011, <https://www.intel.com/content/dam/doc/application-note/pci-sig-sr-iov-primer-sr-iov-technology-paper.pdf>
- ❑ P. Beck, et al., “IBM and Cisco: Together for a World Class Data Center,” IBM Red Book, 2013, 654 pp., ISBN: 0-7384-3842-1, <http://www.redbooks.ibm.com/redbooks/pdfs/sg248105.pdf>
- ❑ R. Emerick, “PCI Express IO Virtualization Overview,” SNIA Education, 2012, https://www.snia.org/sites/default/education/tutorials/2012/fall/networking/RonEmerick_PCI%20Express_%20IO_Virtualization_Overview-r2.pdf (Excellent)
- ❑ R. Sharma, et al., “VSI Discovery and Configuration,” Jan 2010, <http://www.ieee802.org/1/files/public/docs2010/bg-sharma-evb-VSI-discovery-0110-v01.pdf>
- ❑ HP “Server-to-Network Edge Technologies: Converged Networks and Virtual I/O,” March 2010, <http://www.sallustio.ch/blade/Server-to-network%20edge%20technologies.pdf>

Student Questions

Wikipedia Links

- ❑ http://en.wikipedia.org/wiki/Address_Resolution_Protocol
- ❑ <http://en.wikipedia.org/wiki/EtherChannel>
- ❑ http://en.wikipedia.org/wiki/IEEE_802.1aq
- ❑ http://en.wikipedia.org/wiki/Link_aggregation
- ❑ <http://en.wikipedia.org/wiki/MC-LAG>
- ❑ http://en.wikipedia.org/wiki/Network_virtualization
- ❑ http://en.wikipedia.org/wiki/PCI_Express
- ❑ http://en.wikipedia.org/wiki/Port_Aggregation_Protocol
- ❑ http://en.wikipedia.org/wiki/Root_complex
- ❑ http://en.wikipedia.org/wiki/Virtual_Routing_and_Forwarding

Student Questions

Acronyms

- ❑ A-VPLS Advanced Virtual Private LAN Service
- ❑ Access-EPL Access Ethernet Private Line
- ❑ Access-EVPL Access Ethernet Virtual Private Line
- ❑ ADC Application Delivery Controllers
- ❑ API Application Programming Interface
- ❑ CDCP S-Channel Discovery and Configuration Protocol
- ❑ CPU Central Processing Unit
- ❑ DMTF Distributed Management Task Force
- ❑ DVS Distributed Virtual Switching
- ❑ ECP Edge Control Protocol
- ❑ EPL Ethernet Private Line
- ❑ EVB Edge Virtual Bridging
- ❑ EVP-Tree Ethernet Virtual Private Tree
- ❑ EVPL Ethernet Virtual Private Line
- ❑ EVPLAN Ethernet Virtual Private Local Area Network
- ❑ EVPN Ethernet Virtual Private Network
- ❑ FEX Fabric Extender

Student Questions

Acronyms (Cont)

- ❑ GB Giga Byte
- ❑ GMPLS Generalized Multi-Protocol Label Switching
- ❑ GRE Generic Routing Encapsulation
- ❑ H-VPLS Hierarchical Virtual Private LAN Service
- ❑ HSRP Hot Standby Router Protocol
- ❑ IBM International Business Machines
- ❑ IO Input/Output
- ❑ IOV Input/Output Virtualization
- ❑ IP Internet Protocol
- ❑ IPoMPLSoE IP over MPLS over Ethernet
- ❑ IPsec Internet Protocol Security
- ❑ L2TPv3 Layer 2 Tunneling Protocol Version 3
- ❑ LAG Link Aggregation
- ❑ LISP Locator ID Split Protocol
- ❑ MAC Media Access Control

Student Questions

Acronyms (Cont)

- ❑ MPLS-TP Multiprotocol Label Switching Transport
- ❑ MPLS Multi-Protocol Label Switching
- ❑ MR-IOV Multi-Root I/O Virtualization
- ❑ NIC Network Interface Card
- ❑ NVGRE Network Virtualization using GRE
- ❑ NVO3 Network Virtualization Over L3
- ❑ OTV Overlay Transport Virtualization
- ❑ PB Provider Bridge
- ❑ PBB-EVPN Provider Backbone Bridging with Ethernet VPN
- ❑ PBB-TE Provider Backbone Bridge with Traffic Engineering
- ❑ PBB Provider Backbone Bridge
- ❑ PCI-SIG Peripheral Component Interconnect Special Interest Group
- ❑ PCI Peripheral Component Interconnect
- ❑ PCIe Peripheral Component Interconnect Express
- ❑ PF Physical Function

Student Questions

Acronyms (Cont)

- ❑ pM Physical Machine
- ❑ pNIC Physical Network Interface Card
- ❑ pSwitch Physical Switch
- ❑ PW Pseudo Wire
- ❑ PWoGRE Pseudo Wire Over Generic Routing Encapsulation
- ❑ PWoMPLS Pseudo Wire over Multi-Protocol Label Switching
- ❑ SMLT Split Multi-link Trunking
- ❑ SNIA Storage Networking Industry Association
- ❑ SR-IOV Single Root I/O Virtualization
- ❑ STP Spanning Tree Protocol
- ❑ STT Stateless Transport Tunneling
- ❑ TP Transport Profile
- ❑ T-MPLS Transport Multiprotocol Label Switching
- ❑ TRILL Transparent Interconnection of Lots of Link
- ❑ VBE Virtual Bridge Extension

Student Questions

Acronyms (Cont)

- ❑ VDC Virtual Device Context
- ❑ VEB Virtual Edge Bridge
- ❑ VEM Virtual Ethernet Module
- ❑ VEPA Virtual Ethernet Port Aggregator
- ❑ VF Virtual Function
- ❑ VIP Virtual IP
- ❑ VLAN Virtual Local Area Network
- ❑ VM Virtual Machine
- ❑ vNIC Virtual Network Interface Card
- ❑ vPC Virtual PathChannel
- ❑ VPLS Virtual Private LAN Service
- ❑ VPN Virtual Private Network
- ❑ vPort Virtual Port
- ❑ VRF Virtual Routing and Forwarding

Student Questions

Acronyms (Cont)

- ❑ VRRP Virtual Routing Redundancy Protocol
- ❑ VSI Virtual Station Interface
- ❑ VSL Virtual Switch Link
- ❑ VSS Virtual Switch System
- ❑ VXLAN Virtual eXtensible Local Area Network

Student Questions

Scan This to Download These Slides



Raj Jain

<http://rajjain.com>

http://www.cse.wustl.edu/~jain/cse570-21/m_07avb.htm

Student Questions

Related Modules



CSE567M: Computer Systems Analysis (Spring 2013),

https://www.youtube.com/playlist?list=PLjGG94etKypJEKjNAa1n_1X0bWWNyZcof

CSE473S: Introduction to Computer Networks (Fall 2011),

https://www.youtube.com/playlist?list=PLjGG94etKypJWOSPMh8Azcg5e_10TiDw



Wireless and Mobile Networking (Spring 2016),

https://www.youtube.com/playlist?list=PLjGG94etKypKeb0nzyN9tSs_HCd5c4wXF

CSE571S: Network Security (Fall 2011),

<https://www.youtube.com/playlist?list=PLjGG94etKypKvzfVtutHcPFJXumyyg93u>



Video Podcasts of Prof. Raj Jain's Lectures,

<https://www.youtube.com/user/ProfRajJain/playlists>

Student Questions