

Introduction to Software Defined Networking (SDN)

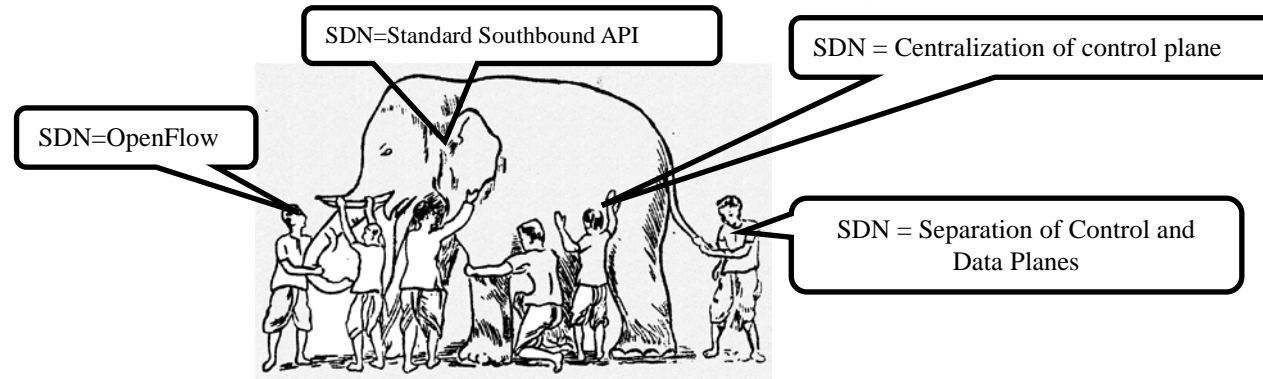

Raj Jain
Washington University in Saint Louis
Saint Louis, MO 63130
Jain@cse.wustl.edu

These slides and audio/video recordings of this class
lecture are at:

<http://www.cse.wustl.edu/~jain/cse570-21/>

Student Questions



1. What is SDN?
2. SDN Controllers
3. Alternative APIs: XMPP, PCE, ForCES, ALTO
4. RESTful APIs and OSGi Framework

Note: This is the second module of three modules on OpenFlow, SDN and NFV in this course.

Student Questions

Origins of SDN

- ❑ SDN originated from OpenFlow
- ❑ Centralized Controller
 - ⇒ Easy to program
 - ⇒ Change routing policies on the fly
 - ⇒ Software Defined Network (SDN)

❑ Initially, SDN=

- Separation of Control and Data Plane
- Centralization of Control
- OpenFlow to talk to the data plane

❑ Now the definition has changed significantly.

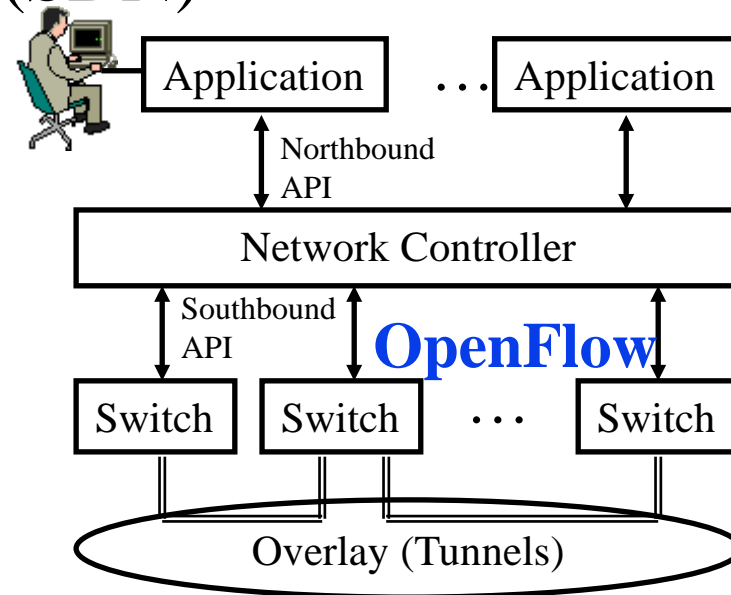

Student Questions

Three Features that Define SDN

1. **Abstract the Hardware:** No dependence on physical infrastructure. Software API.
2. **Programmable:** Shift away from static manual operation to fully configurable and dynamic
3. **Centralized Control of Policies:**
Policy delegation and management

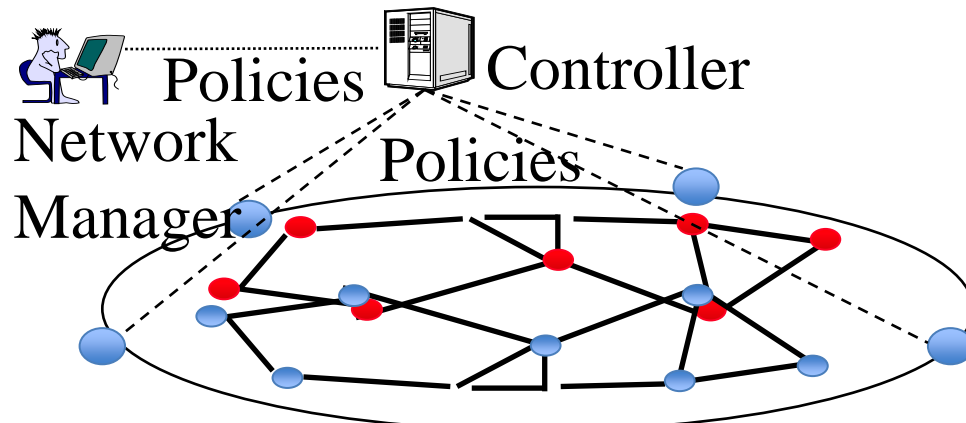

Student Questions

What = Why We need SDN?

- 1. Virtualization:** Use network resource without worrying about where it is physically located, how much it is, how it is organized, etc. Abstraction \Rightarrow Virtualization.
- 2. Orchestration:** Should be able to control and manage thousands of devices with one command.
- 3. Programmable:** Should be able to change behavior on the fly.
- 4. Dynamic Scaling:** Should be able to change size, quantity
Virtualization \Rightarrow Scaling
- 5. Automation:** To lower OpEx minimize manual involvement
 - Troubleshooting
 - Reduce downtime
 - Policy enforcement
 - Provisioning/Re-provisioning/Segmentation of resources
 - Add new workloads, sites, devices, and resources

Student Questions

Why We need SDN? (Cont)

6. Visibility: Monitor resources, connectivity

7. Performance: Optimize network device utilization

- Traffic engineering/Bandwidth management
- Capacity optimization
- Load balancing
- High utilization
- Fast failure handling

8. Multi-tenancy: Tenants need complete control over their addresses, topology, and routing, security

9. Service Integration: Load balancers, firewalls, Intrusion Detection Systems (IDS), provisioned on demand and placed appropriately on the traffic path

Student Questions

Why We need SDN? (Cont)

10. Openness: Full choice of “How” mechanisms

⇒ Modular plug-ins

⇒ Abstraction:

➤ Abstract = Summary = Essence = General Idea

⇒ Hide the details.

➤ Also, abstract is opposite of concrete

⇒ Define tasks by APIs and **not by how** it should be done. E.g., send from A to B. Not OSPF.

Student Questions

Ref: <http://www.networkworld.com/news/2013/110813-onug-sdn-275784.html>

Software Defined Anything (SDx)

- ❑ Tsunami of software defined things
 - Software Defined Networking (SDN)
 - Software Defined Datacenter (SDDC)
 - Software Defined Storage (SDS)
 - Software Defined Compute (SDC)
 - Software Defined Infrastructure (SDI)

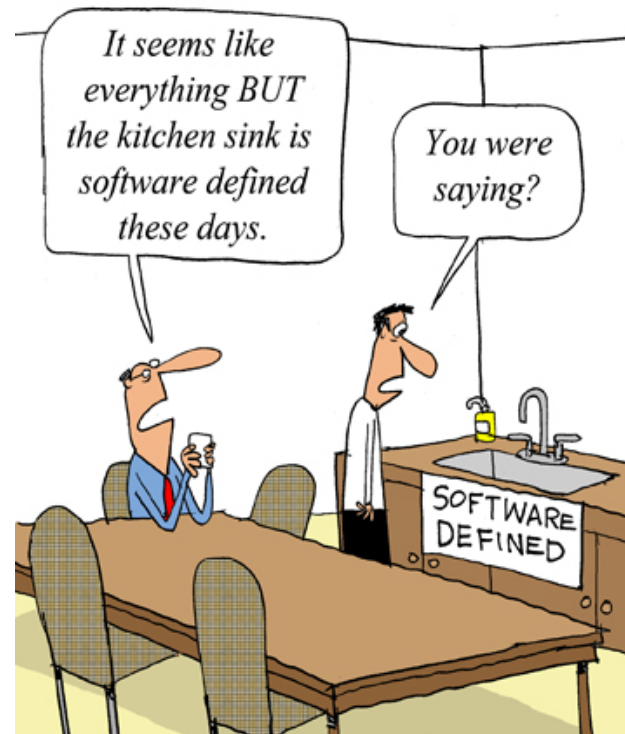

Student Questions

Centralized vs. Distributed

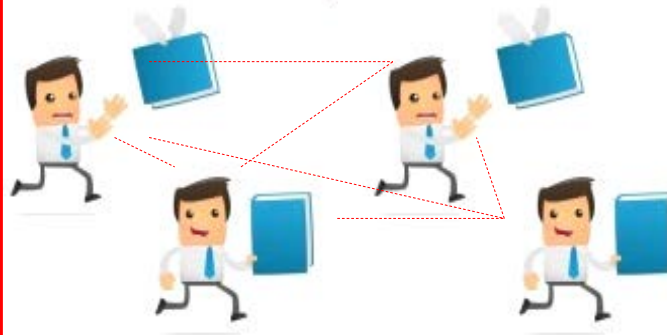
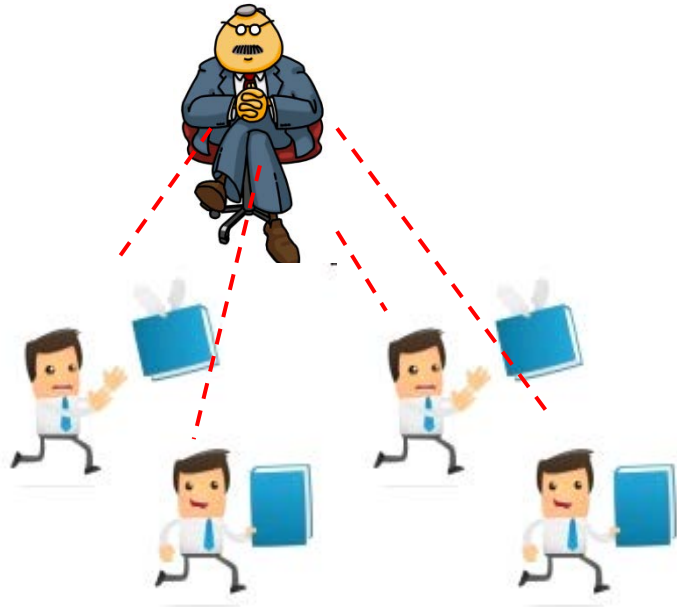

- ❑ Fast Response to changes
- ❑ Fast Consistency
- ❑ Less overhead \Rightarrow Scalable
- ❑ Single Point of Failure

- ❑ Time to converge
- ❑ Slow consistency
- ❑ Not scalable
- ❑ Fault Tolerant

Student Questions

What SDN is Not?

SDN = OpenFlow

SDN = Standard Southbound API

SDN = Centralization of control plane

SDN = Separation of Control and Data Planes

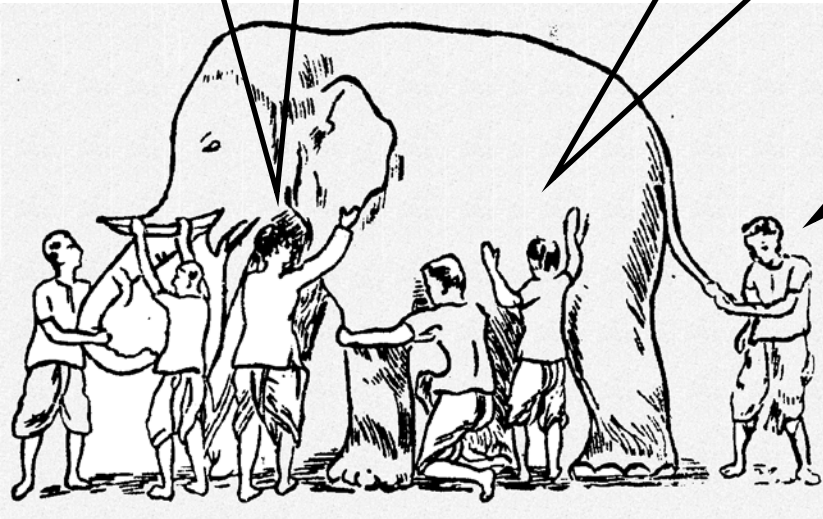

- ❑ All of these are mechanisms.
- ❑ SDN is *not* about a mechanism.
- ❑ It is a framework \Rightarrow Many solutions

Student Questions

Four Confusions About SDN

1. Policies vs. Control:

Control = All bits and messages not sent by the user
In IP, control includes all header bits and all routing messages.

2. Separation of Control Plane:

Elements have only data plane and have no brains

3. SDN vs. OpenFlow:

OpenFlow is the father of SDN but not SDN.

4. Need OpenFlow:

- OpenFlow is micro-management.
- It is not scalable.
- For large infrastructure, need scalable solutions.

Student Questions

Separation vs. Centralization

Separation of Control Plane



Centralization of Policies



Micromanagement is not scalable

Student Questions

Current SDN Debate: What vs. How?

1. SDN is easy if control is centralized but not necessary.
Distributed/hierarchical solutions may be required for fail-safe operation.
2. Complete removal of control plane may be harmful.
Exact division of control plane between centralized controller and distributed forwarders is yet to be worked out

Student Questions

Current SDN Debate: What vs. How? (Cont)

3. SDN is easy with a standard southbound protocol like OpenFlow but one protocol may not work/scale in all cases
 1. Diversity of protocols is a fact of life.
 2. There are no standard operating systems, processors, routers, or Ethernet switches.
4. If industry finds an easier way to solve the same problems by another method, that method may win. E.g., ATM vs. MPLS.

Student Questions

Flavors of SDN

1. **OpenDaylight: Multi-Protocol Southbound**
2. **Bare Metal Switches + Network Operating System**
 - a. Switches from Dell, Edgecore, HP, Penguin, QCT, Agema, Supermicro
 - b. Open Network Install Environment (ONIE) on a set of programmable switch
 - c. Network operating system: Alcatel-Lucent, Arista, Big Switch, Broadcom, Brocade, Cisco, Cumulus, Dell, Ericsson, Extreme, HP, Juniper, OCP, Pica8, Pluribus
3. **Network Virtualization/Overlay: VMWare's NSX**
4. **ONF SDN: OpenFlow southbound**

All provide: Abstraction, Programmability, and Centralization

Ref: <http://onie.org/>, http://www.opencompute.org/wiki/Networking/ONIE/HW_Status,
https://en.wikipedia.org/wiki/List_of_SDN_controller_software

Source: Alan J Weissberger

Washington University in St. Louis

<http://www.cse.wustl.edu/~jain/cse570-21/>

©2021 Raj Jain

Student Questions



Floodlight

- ❑ **Java** based OpenFlow controller based on Beacon runs within a JVM. Developers from Big Switch Networks
- ❑ Indigo: Software to make switch hardware OpenFlow compatible
- ❑ Floodlight is the core of Big Switch Controller from Big Switch Networks

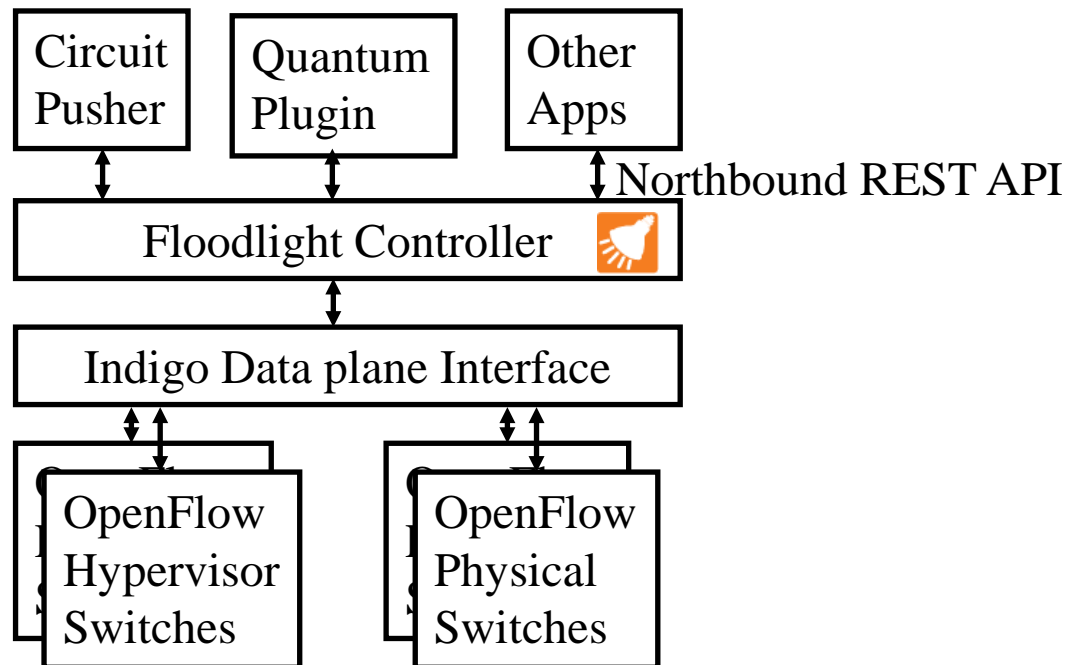

Ref: S. Azodolmolky, "Software Defined Networking with OpenFlow," Packt Publishing, October 2013, 152 pp., ISBN:978-1-84969-872-6 (Safari Book)
Washington University in St. Louis

<http://www.cse.wustl.edu/~jain/cse570-21/>

©2021 Raj Jain

Student Questions

Floodlight (Cont)

- ❑ A number of real-world networking applications
 - **Neutron plug-in** for OpenStack cloud management system
 - **Static Flow Pusher**: Allows users to manually insert flows
 - **Circuit Pusher**: Creates permanent entries on all switches along the path
 - **Firewall**: Enforces access control list (ACL) rules on packets
 - **Big Virtual Switch**: Automates network provisioning for a large scale data centers. Includes provisioning, multi-tenant partitioning

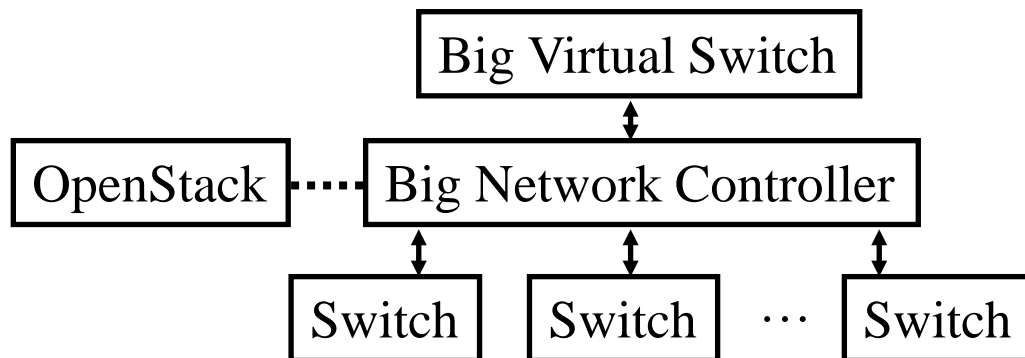

Student Questions

Ref: <http://www.projectfloodlight.org/floodlight/>

ONOS

- ❑ Open Network Operating System:
Distributed OpenFlow OS for a large WAN
- ❑ Initially OpenFlow-only. Now multi-protocol

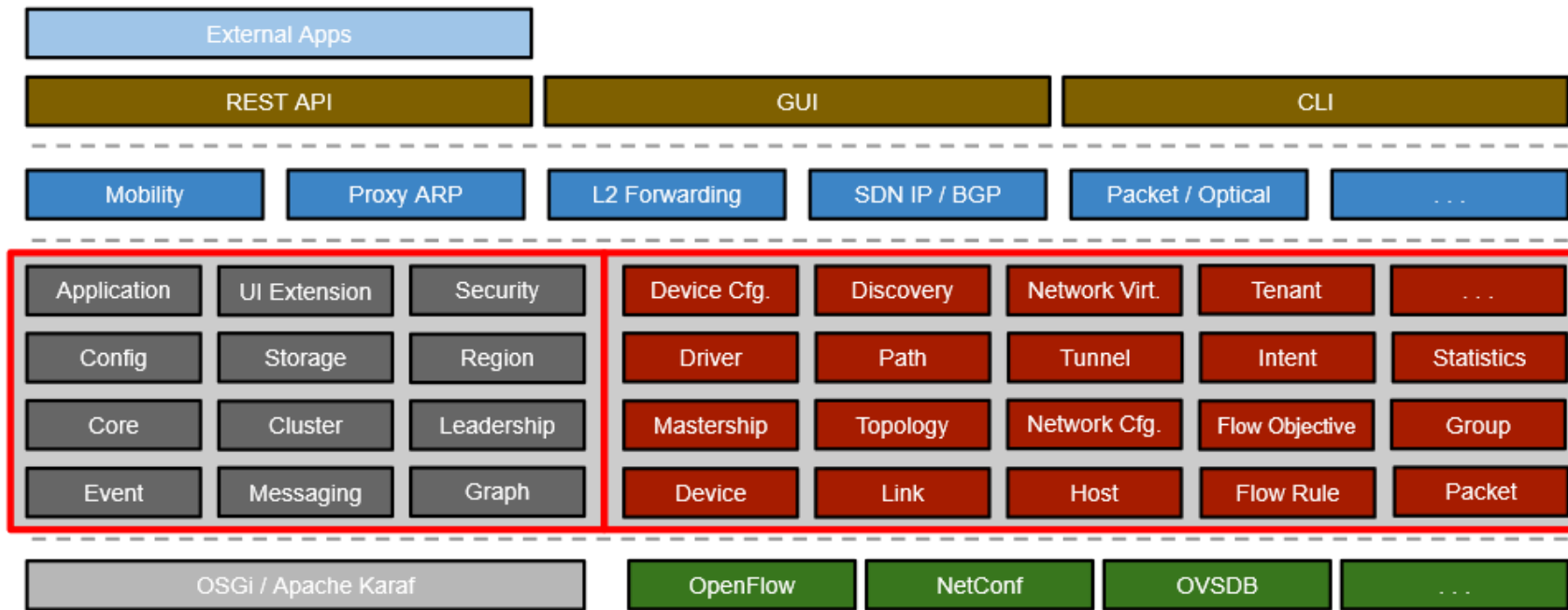

Student Questions

Ref: ONOS Architecture, https://docs.google.com/presentation/d/1Y4S82YZysqKAZW4kKm-6IIO04h_mnrRQyfrsCdt-I/edit?usp=sharing

OpenDaylight: Multi-Protocol SDN

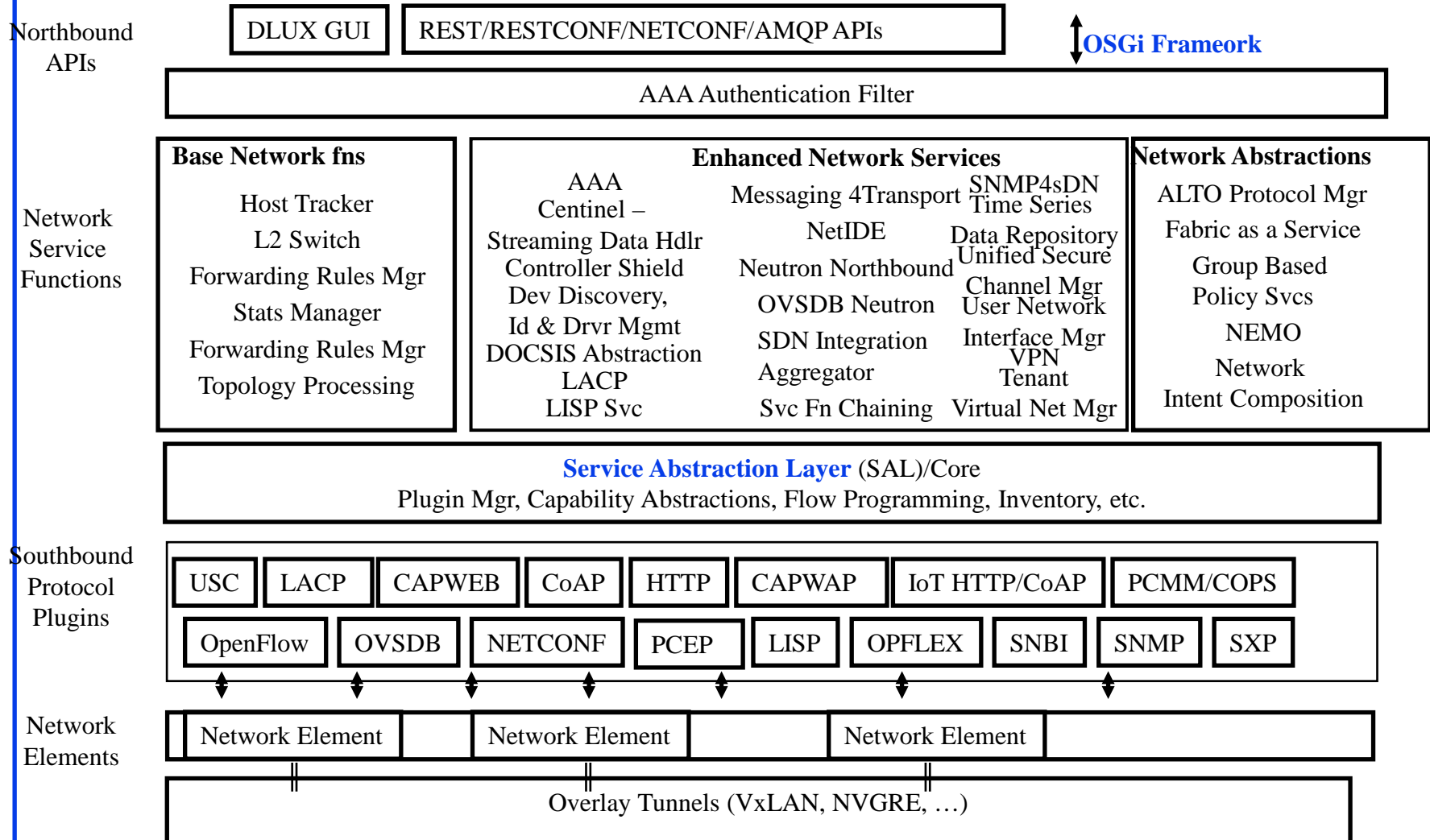

Student Questions

OpenDaylight SDN Controller Platform (OSCP)

- ❑ Multi-company collaboration under Linux foundation
- ❑ Many projects including OpenDaylight Controller
- ❑ Supports multiple southbound protocols via plug-ins including OpenFlow
- ❑ Dynamically linked in to a Service Abstraction Layer (SAL)
Abstraction \Rightarrow SAL figures out how to fulfill the service requested by higher layers irrespective of the southbound protocol
- ❑ Modular design using **OSGI framework**
- ❑ A rich set of North-bound APIs via **RESTful** services for loosely coupled applications and OSGI services for co-located applications using the same address space

Ref: C. Eckel, "OpenDaylight as a Platform for Network Programmability,"

<http://events17.linuxfoundation.org/sites/events/files/slides/OpenDaylight-Network-Programmability.pdf>

https://wiki.opendaylight.org/view/Main_Page

Student Questions

Examples Alternative APIs

- ❑ Southbound APIs: PCEP, BGP, ...
- ❑ Northbound APIs: ALTO, ...
- ❑ Overlay: VxLAN, TRILL, LISP, ...
- ❑ Configuration API: NETCONF, RESTCONF, ...
- ❑ Controller: PCE, ...

Student Questions

Ref: T. Nadeau and K. Gray, "SDN," O'Reilly, 2013, 384 pp, ISBN:978-1-449-34230-2 (Safari Book)

Path Computation Element (PCE)

- ❑ MPLS and GMPLS require originating routers to find paths that satisfy multiple constraints including not using any backup routers and having a given bandwidth etc.
- ❑ This may require more computer power or network knowledge than a router may have.
- ❑ IETF PCE working group has developed a set of protocols that allow a Path computation client (PCC), i.e., router to get the path from path computation element (PCE)
- ❑ PCE may be centralized or may be distributed in many or every router.

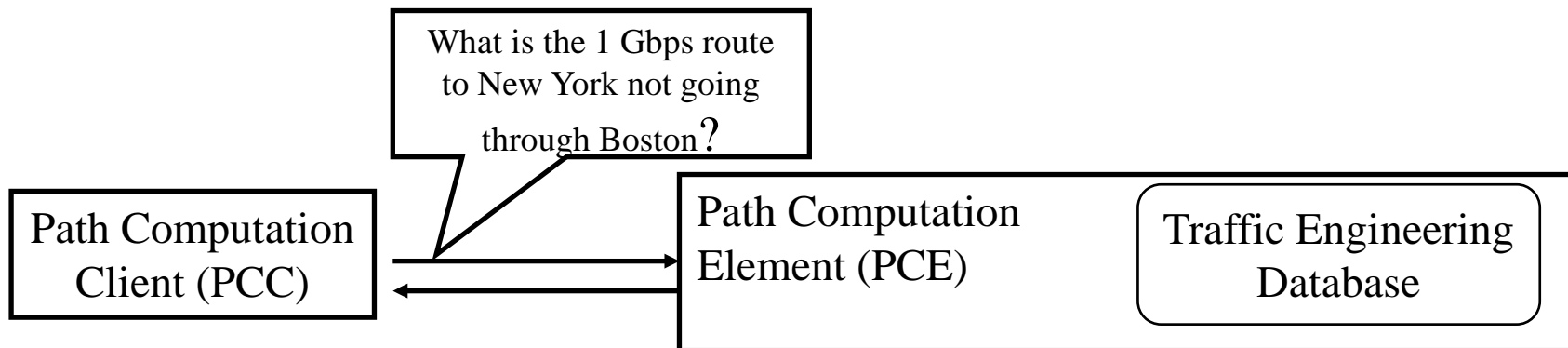

Student Questions

PCE (Cont)

- ❑ PCE separates the route computation function from the forwarding function.
- ❑ Both functions may be resident in the same box or different boxes.
- ❑ 25+ RFCs documenting protocols for:
 - PCE-to-PCC communication
 - PCE-to-PCE communication (Multiple PCEs)
 - PCE discovery

Ref: <http://datatracker.ietf.org/wg/pce/>

Ref: http://en.wikipedia.org/wiki/Path_computation_element

Washington University in St. Louis

<http://www.cse.wustl.edu/~jain/cse570-21/>

©2021 Raj Jain

Student Questions

Application Layer Traffic Optimization (ALTO)

- ❑ IETF working group to optimize P2P traffic
⇒ Better to get files from nearby peers
- ❑ Provide guidance in peer selection
- ❑ ALTO Server: Has knowledge of distributed resources
- ❑ ALTO Client: Requests information from servers about the appropriate peers
- ❑ Ratio Criteria: Topological distance, traffic charges, ...
- ❑ ALTO Server could get information from providers or from nodes about their characteristics, e.g., flat-rate or volume based charging
- ❑ A client may get the list of potential peers and send it to the server, which can return a ordered list
- ❑ Also need a protocol for ALTO server discovery



Student Questions

Ref: J. Seedorf and E. Berger, “ALTO Problem Statement,” http://datatracker.ietf.org/doc/rfc5693/?include_text=1

Ref: Y. Lee, et al., “ALTO Extensions for collecting Data Center Resource Information,”

http://datatracker.ietf.org/doc/draft-lee-alto-ext-dc-resource/?include_text=1

Washington University in St. Louis

<http://www.cse.wustl.edu/~jain/cse570-21/>

©2021 Raj Jain

ALTO Extension

- ❑ Now being extended to locate resources in data centers
- ❑ Need to be able to express
 - resource (memory, storage, CPU, network) availability
 - Cost of these resources
 - Constraints on resources, e.g., bandwidth
 - Constraints on structure, e.g., Power consumption
- ❑ ALTO client gets the info from various providers
- ❑ Issue of privacy of resource and cost info for the provider

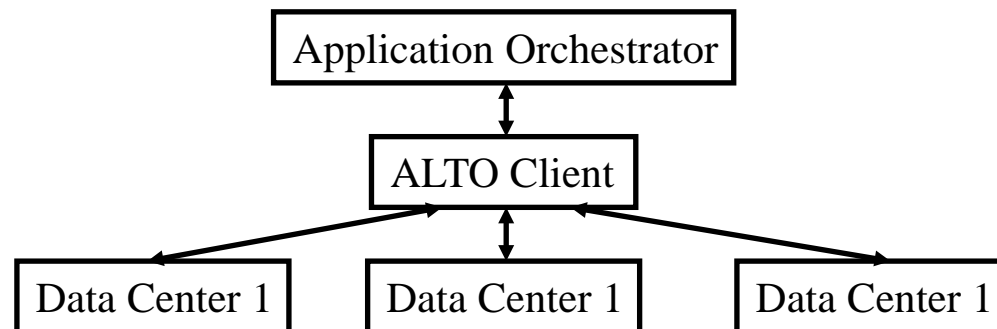

Student Questions



XMPP

- ❑ Extensible Messaging and Presence Protocol
- ❑ **Extensible** ⇒ Using XML
- ❑ Similar to SMTP email protocol but for near real-time communication
- ❑ Each client has an ID, e.g., john@wustl.edu/mobile (John's mobile phone)
- ❑ Client sets up a connection with the server ⇒ Client is online
- ❑ **Presence**: Server maintains contact addresses and may let other contacts know that this client is now on-line
- ❑ **Messaging**: When a client sends a “chat” message to another clients, it is forwarded to these other clients
- ❑ Messages are “*pushed*” (⇒ real-time) as opposed to “*polled*” as in SMTP/POP emails.

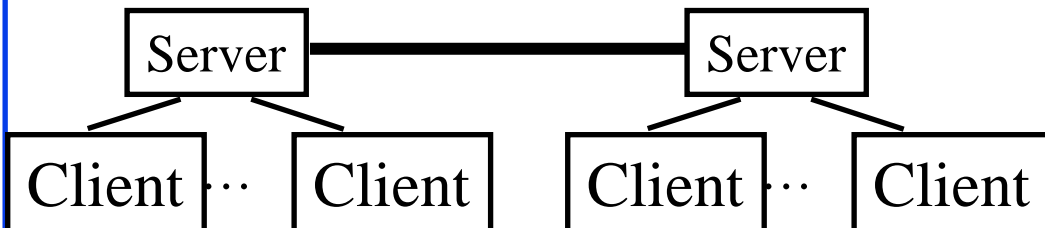

Ref: P. Saint-Andre, et al. “XMPP: The Definitive Guide,” O’Reilly, 2009, 320 pp., ISBN:9780596521264 (Safari Book)
Washington University in St. Louis <http://www.cse.wustl.edu/~jain/cse570-21/> ©2021 Raj Jain

Student Questions



XMPP

XMPP (Cont)

- ❑ XMPP is IETF standardization of Jabber protocol
- ❑ RFC 6121 defines XMPP using TCP connections.
But HTTP is often used as transport to navigate firewalls
- ❑ All messages are XML encoded
⇒ Not efficient for binary file transfers
⇒ Out-of-band binary channels are often used with XMPP.
- ❑ A number of open-source implementations are available
- ❑ Variations of it are widely used in most instant messaging programs including Google, Skype, Facebook, ..., many games
- ❑ Used in IoT and data centers for management. Network devices have XMPP clients that respond to XMPP messages containing CLI management requests ⇒ You can manage your network using any other XMPP client, e.g., your mobile phone
- ❑ Arista switches can be managed by XMPP, Juniper uses XMPP as a southbound protocol for SDN

Student Questions

XMPP in Data Centers

- Everything is an XMPP entity.
It has its own contact list and authorizations.

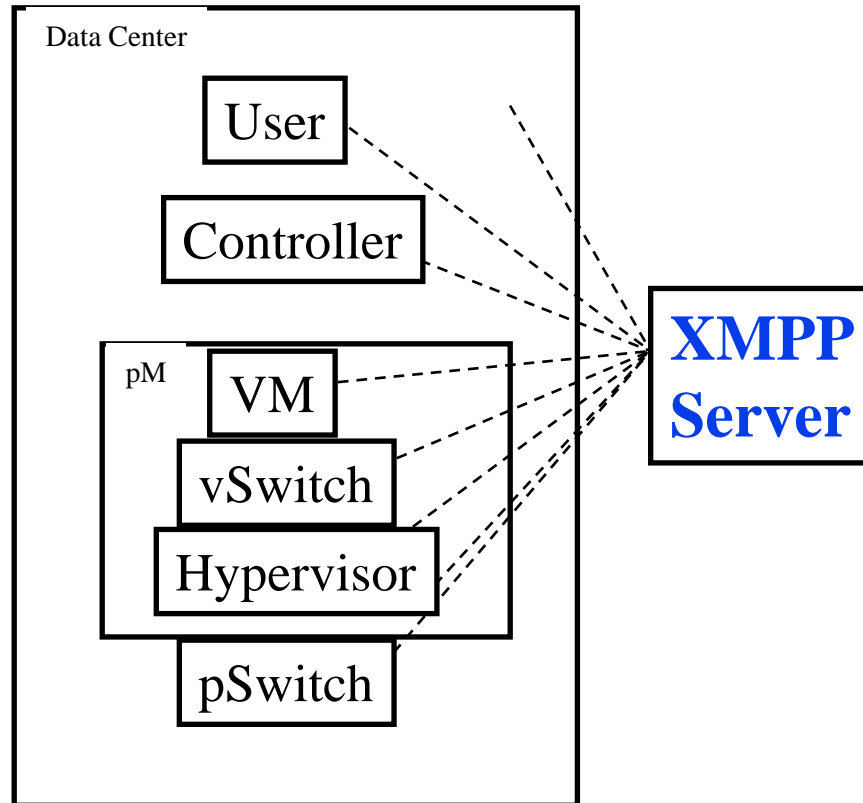

Student Questions

OpenDaylight Tools

1. **Applications:** Provides Virtual Network Segments (VNS) for each tenant
 1. OpenDaylight Network Virtualization (ONV):
 2. OpenDaylight Virtual Tenant Network (VTN)
2. **Services:**
 1. Unified Secure Channel Manager
3. **Northbound APIs:**
 1. **REST:** Representational State Transfer (like HTTP)
 2. **RESTCONF:** RESTful Configuration
 3. **NETCONF:** Network Configuration
 4. **Blux:** Northbound API using AngularJS, an extension of HTML by Google for dynamic views
 5. **AMQP:** Advanced Message Queuing Protocol

Student Questions

OpenDaylight Tools (Cont)

4. Southbound APIs:

1. OpenFlow Plug-in + Protocol Library (V1.0, V1.1,...)
2. Locator ID Separation Protocol (LISP) Mapping Service
3. SNMP4SDN
4. BGP Link State Path Control Element Protocol

5. Overlay:

1. Open Distributed Overlay Virtual Ethernet (DOVE):
Like VxLAN but does not use IP Multicast

6. Configuration:

1. OpenDaylight YANG Tools: NETCONF
2. Open vSwitch Database (OVSDB) Integration

Student Questions

Open Network Linux

- ❑ Linux distribution for “*open hardware*” bare metal switches
- ❑ Part of Open Compute Project
- ❑ Supports multiple *switch fabric APIs*:
 - **OF-DPA**: OpenFlow Data Plane Abstraction (API) for Broadcom chips
 - **OpenNSL**: Open Network Switch Layer for Broadcom switches
 - **SAI**: Switch Abstraction Interface (vendor independent API to control forwarding elements)
- ❑ Compatible with many open-source *forwarding agents* or routing protocol suites

Ref: <http://opennetlinux.org/> , <https://github.com/Broadcom-Switch/OpenNSL>, <https://github.com/Broadcom-Switch/of-dpa>, <https://github.com/opencomputeproject/SAI>

Washington University in St. Louis

<http://www.cse.wustl.edu/~jain/cse570-21/>

©2021 Raj Jain

Student Questions

Bare Metal Switches

- ❑ Hardware that can be used to load different network operating systems
- ❑ Open Network Linux is supported by hardware from: | Accton/Edge-Core, Quanta, Dell, Mellanox, Netberg, Inventec, Celestica, HPE, DNI, Ingrasys, and Alpha Networks

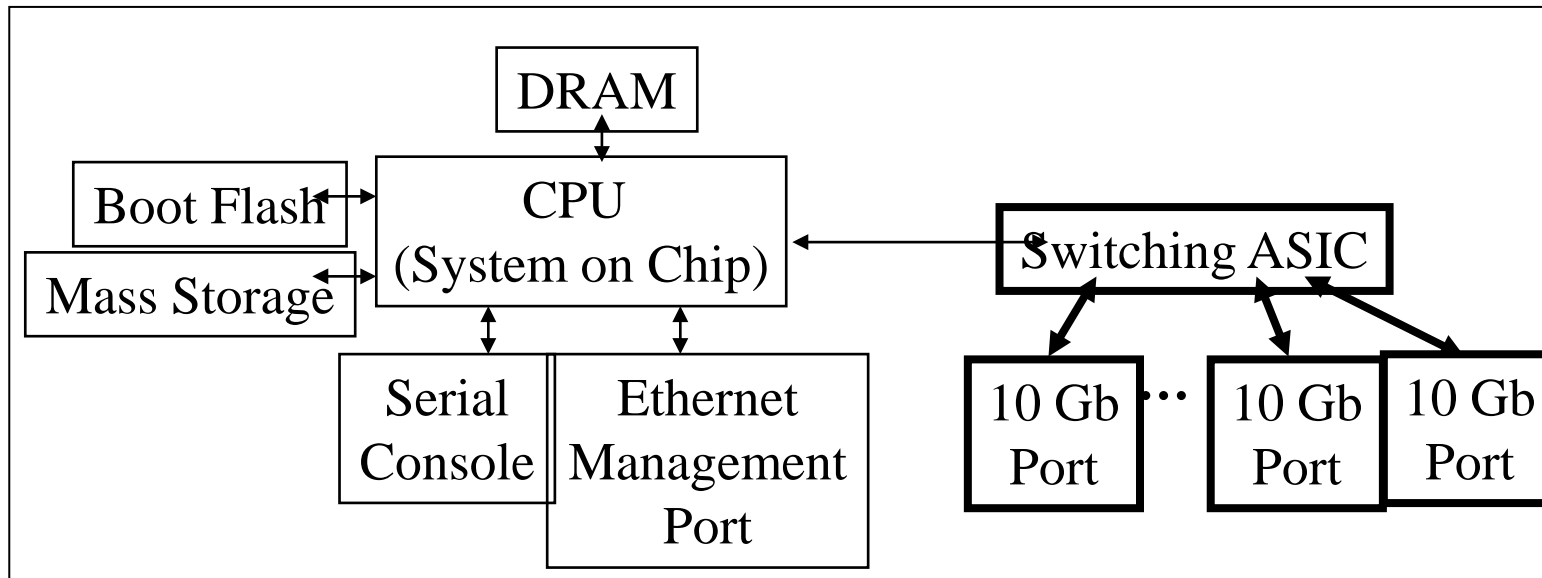

Student Questions

Open Source Forwarding Agents

- ❑ **Quagga**: A popular open source routing software suite including OSPF, RIP, BGP, ...
- ❑ **FRRouting**: a fork of Quagga. Linux routing protocol suite including BGP, IS-IS, LDP, OSPF, PIM, and RIP (Free Range Routing?)
- ❑ **BIRD**: Internet Routing Daemon developed as a school project at Charles University, Prague. Supports IPv4, IPv6, BGP, RIP, OSPF, ...
- ❑ Facebook Open Switching System (**FBOSS**): S/w stack for controlling and managing network switches with several user-space applications
- ❑ Azure Software for Open Networking in the Cloud (**SONiC**)
- ❑ Google **gNOS**

Ref: <https://www.nongnu.org/quagga/>, <https://www.opensourcerouting.org/>, <http://bird.network.cz/>,
<https://github.com/facebook/fboss>, <http://azure.github.io/SONiC/>

Washington University in St. Louis

<http://www.cse.wustl.edu/~jain/cse570-21/>

©2021 Raj Jain

Student Questions

Open Network Install Environment (ONIE)

- ❑ Part of **Open Compute Project (OCP)** open source initiative
- ❑ Allows many different “**Network Operating Systems (NOS)**” on bare metal network switches
- ❑ Like a firmware that locates the NOS boot image and loads it
- ❑ ONIE sets the environment on the first boot and is not required subsequently

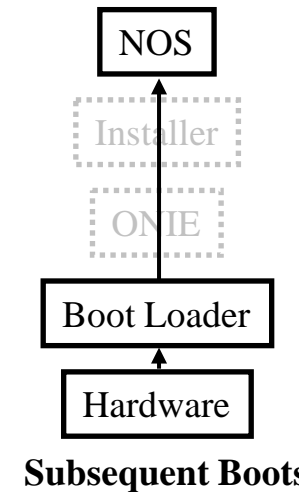
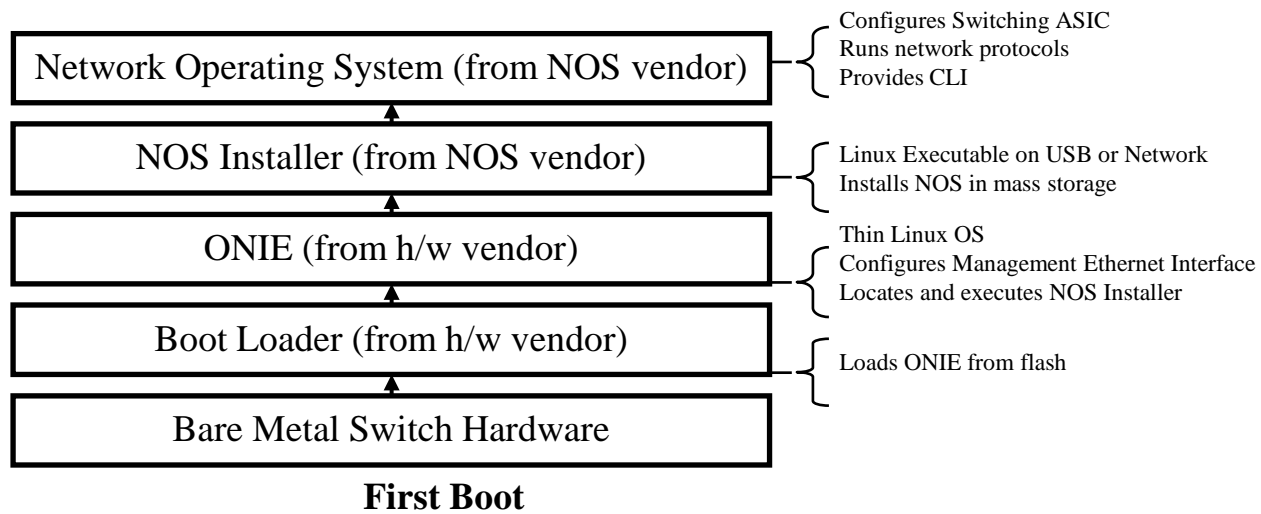

Ref: ONIE Overview, <https://opencomputeproject.github.io/onie/overview/index.html#onie-overview>

Student Questions

Mininet

- ❑ Widely used open source network emulation environment.
- ❑ Can simulate a number of end-hosts, switches, routers, links on a Linux
- ❑ Used for rapid prototyping of software define networks
- ❑ Built-in Open vSwitch, and a OpenFlow capable switch
- ❑ Command line launcher and Python API for creating networks of varying sizes, e.g., *mn -topo tree,depth=2,fanout=3*
- ❑ Useful diagnostic commands like iperf, ping, and other commands in a host, e.g., *mininet> h11 ifconfig -a*
- ❑ Mininet code for several popular commercial switches are available.

Ref: <https://github.com/mininet/mininet> , <http://www.brianlinkletter.com/set-up-mininet/>

Student Questions

RESTful APIs

- ❑ Software architecture style developed by W3C.
- ❑ Introduced by Roy Fielding in his PhD thesis.
- ❑ WWW uses this style. Very popular in other applications.
- ❑ Goals: Scalability, Generality, Independence, and allow intermediate components
- ❑ Client-Server Model: Clients and servers can be developed independently.
- ❑ Server is stateless
- ❑ Responses can be cached for the specified time
- ❑ Intermediate Servers (Proxies) can respond. End point is not critical.

Student Questions

REST (Cont)

- ❑ Create, Read, Update, Delete (CRUD) Operations
- ❑ Uniform Interface: GET (Read), POST (Insert), PUT (write), DELETE
- ❑ Resources identified by global identifiers, e.g., URI in Web.
- ❑ Get `http://<fqdn-or-ip-address>/rest/v1/model/<data-type>/<optional-id>?<optional-query-params>`
E.g., GET `http://odcp.org/rest/v1/model/controller-node`
- ❑ Data Types: Controller node, Firewall rule, Topology configuration, Switch, Port, link, flow entry, VLAN, ...
- ❑ Data types can include commercial entities, such as, Big Virtual Switch from Big Switch Networks, vCenter from VMware, ...
- ❑ If optional-id and query parameters are omitted, the returned text includes all of the items of the given data type.

Ref: http://en.wikipedia.org/wiki/Representational_state_transfer

Student Questions

OSGi Framework

- ❑ Initially, Open Services Gateway initiative
- ❑ A set of specifications for dynamic application composition using reusable Java components called bundles
- ❑ Bundles publish their services with OSGi services registry and can find/use services of other bundles

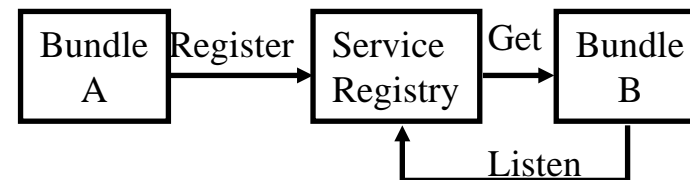
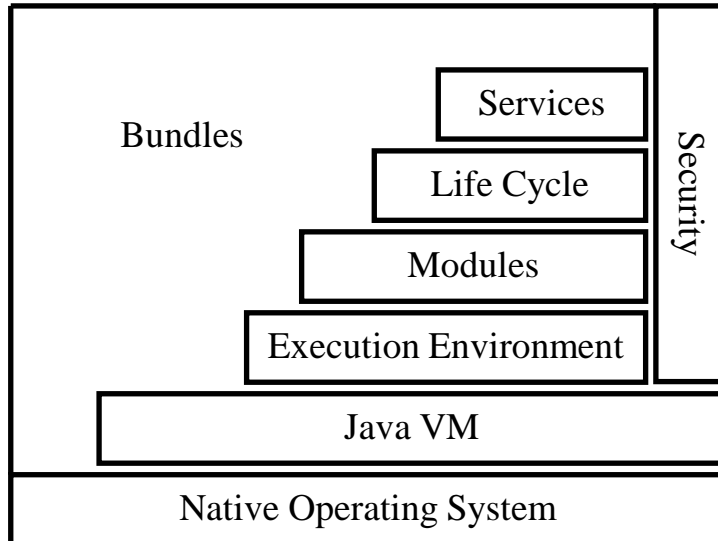

Student Questions

OSGi (Cont)

- ❑ Bundles can be installed, started, stopped, updated or uninstalled using a lifecycle API
 - ❑ Modules defines how a bundle can import/export code
 - ❑ Security layer handles security
 - ❑ Execution environment defines what methods and classes are available in a specific platform
 - ❑ A bundle can get a service or it can listen for a service to appear or disappear.
 - ❑ Each service has properties that allow others to select among multiple bundles offering the same service
 - ❑ Services are dynamic. A bundle can decide to withdraw its service. Other bundles should stop using it
- ⇒ Bundles can be installed and uninstalled on the fly.

Student Questions

Summary



1. SDN = Abstraction + Programmability + Centralization
SDN = Disaggregation of h/w and s/w
= Bare metal switches + ONIE + ONL
2. OpenFlow originated SDN but now many different southbound and northbound APIs, intermediate services and tools are being discussed and implemented by the industry, e.g., XMPP, PCE, ALTO
3. OpenDaylight and ONOS are SDN Controllers.
Differ on how much open.
4. Mininet for network simulation
5. REST=HTTP APIs
OSGI framework for modularity

Student Questions

Reading List

- ❑ Thomas D. Nadeau, Ken Gray, "SDN: Software Defined Networks," O'Reilly Media, Inc., August 2013, 384 pp., ISBN:978-1-4493-4230-2 (Safari Book).
- ❑ Jim Doherty, "SDN and NFV Simplified: A Visual Guide to Understanding Software Defined Networks and Network Function Virtualization," Addison-Wesley Professional, March 2, 2016, 320 pp., ISBN:978-0-13-430739-8 (Safari Book).
- ❑ Reza Toghraee, "Learning OpenDaylight," Packt Publishing, May 2017, 336 pp., ISBN:978-1-78217-452-3 (Safari Book).
- ❑ Antonio Sanchez Monge; Krzysztof Grzegorz Szarkowicz, "MPLS in the SDN Era," O'Reilly Media, Inc., December 2015, 920 pp., ISBN:978-1-4919-0545-6 (Safari Book).

Student Questions

Wikipedia Links

- ❑ http://en.wikipedia.org/wiki/Software-defined_networking
- ❑ http://en.wikipedia.org/wiki/Representational_state_transfer
- ❑ <http://en.wikipedia.org/wiki/OSGI>
- ❑ <http://en.wikipedia.org/wiki/XMPP>
- ❑ http://en.wikipedia.org/wiki/Path_computation_element

Student Questions

References

- ❑ J. Seedorf and E. Berger, “ALTO Problem Statement,” http://datatracker.ietf.org/doc/rfc5693/?include_text=1
- ❑ Y. Lee, et al., “ALTO Extensions for collecting Data Center Resource Information,” http://datatracker.ietf.org/doc/draft-lee-alto-ext-dc-resource/?include_text=1
- ❑ <http://www.osgi.org/Technology/WhatIsOSGi>
- ❑ <http://www.sdncentral.com/sdn-use-cases/>
- ❑ https://wiki.opendaylight.org/view/OpenDaylight_SDN_Controller_Platform_%28OSCP%29:Proposal
- ❑ <http://datatracker.ietf.org/wg/pce/>
- ❑ https://wiki.opendaylight.org/view/Main_Page
- ❑ <http://events17.linuxfoundation.org/sites/events/files/slides/OpenDaylight-Network-Programmability.pdf>
- ❑ OpenDaylight Components and Tools, <https://wiki.opendaylight.org>

Student Questions

References (Cont)

- ❑ Oswald Coker, Siamak Azodolmolky, "Software-Defined Networking with OpenFlow - Second Edition," Packt Publishing, October 2017, 246 pp., ISBN:978-1-78398-429-9 (Safari Book).
- ❑ William Stallings, "Foundations of Modern Networking: SDN, NFV, QoE, IoT, and Cloud," Addison-Wesley Professional, October 2015, 544 pp., ISBN:0-13-417539-5 (Safari Book).
- ❑ Russ White, Jeff Tantsura, "Navigating Network Complexity: Next-generation Routing with SDN, Service Virtualization, and Service Chaining," Addison-Wesley Professional, November 2015, 320 pp., ISBN:0-13-398792-2 (Safari Book).
- ❑ Abhishek Ratan, "Practical Network Automation," Packt Publishing, November 2017, 266 pp., ISBN:978-1-78829-913-8 (Safari Book).
- ❑ Scott S. Lowe, Matt Oswalt, Jason Edelman, "Network Programmability and Automation," O'Reilly Media, Inc., February 2018, 581 pp., ISBN:978-1-4919-3125-7 (Safari Book).
- ❑ Guy Pujolle, "Software Networks," John Wiley & Sons, August 2015, 260 pp., ISBN:978-1-119-00796-8 (Safari Book).

Student Questions

References (Cont)

- ❑ Sriram Subramanian, Sreenivas Voruganti, "Software-Defined Networking (SDN) with OpenStack," Packt Publishing, October 2016, 216 pp., ISBN:978-1-78646-599-3 (Safari Book).
- ❑ Paul Goransson, Chuck Black, Timothy Culver, "Software Defined Networks, 2nd Edition," Morgan Kaufmann, October 2016, 436 pp., ISBN:978-0-12-804555-8 (Safari Book).
- ❑ Patricia A. Morreale, James M. Anderson, "Software Defined Networking," CRC Press, September 2015, 186 pp., ISBN:1-4822-3864-0 (Safari Book).
- ❑ V. Josyula, M. Orr, and G. Page, "Cloud Computing: Automating the Virtualized Data Center," Cisco Press, 2012, 392 pp., ISBN: 1587204347 (Safari Book).
- ❑ P. Saint-Andre, et al., "XMPP: The Definitive Guide," O'Reilly, 2009, 320 pp., ISBN:9780596521264 (Safari Book)

Student Questions

Acronyms

- ❑ ACI Application Policy Infrastructure
- ❑ ACL Access Control List
- ❑ AEX Application Information Exposure
- ❑ ALG Application Level Gateway
- ❑ ALTO Application Layer Traffic Optimization
- ❑ AMQP Advanced Message Queueing Protocol
- ❑ ANDSF Access Network Discovery and Selection Function
- ❑ API Application Programming Interface
- ❑ APIC Application Policy Infrastructure Controller
- ❑ ARP Address Resolution Protocol
- ❑ ATIS Association for Telecom Industry Solutions
- ❑ ATM Asynchronous Transfer Mode
- ❑ AVNP Active Virtual Network Management Protocol
- ❑ BGP Border Gateway Protocol
- ❑ BNC Big Switch Network Controller
- ❑ BSD Berkeley Software Distribution

Student Questions

Acronyms (Cont)

- ❑ BUM Broadcast, Unknown, and Multicast
- ❑ CDN Content Distribution Network
- ❑ CDNI Content Distribution Network Interconnection
- ❑ CE Control Element
- ❑ CLI Command Line Interface
- ❑ CMS Content Management System
- ❑ CPU Central Processing Unit
- ❑ CRUD Create, Read, Update, Delete
- ❑ CSP Cloud Service Provider
- ❑ DHCP Dynamic Host Control Protocol
- ❑ DNS Domain Name System
- ❑ DOCSIS Data over Cable Service Interface Specification
- ❑ DOVE Distributed Overlay Virtual Ethernet
- ❑ DVS Distributed Virtual Switch
- ❑ EID Endpoint Identifier
- ❑ ETSI European Telecommunications Standards Institute

Student Questions

Acronyms (Cont)

- ❑ FCAPS Faults, configuration, accounting, performance , and security
- ❑ FE Forwarding Element
- ❑ FE Forwarding Element
- ❑ ForCES Forwarding and Control Element Separation
- ❑ GMPLS Generalized Multi-Protocol Label Switching
- ❑ GUI Graphical User Interface
- ❑ HTML Hypertext Markup Language
- ❑ HTTP Hypertext Transfer Protocol
- ❑ I2AEX Infrastructure to Application Information Exposure
- ❑ IaaS Infrastructure as a Service
- ❑ ID Identifier
- ❑ IDS Intrusion Detection System
- ❑ IEEE Institution of Electrical and Electronic Engineers
- ❑ IETF Internet Engineering Task Force
- ❑ IGP Interior Gateway Protocol
- ❑ IoT Internet of Things

Student Questions

Acronyms (Cont)

- ❑ IP Internet Protocol
- ❑ IPv4 Internet Protocol version 4
- ❑ IPv6 Internet Protocol version 6
- ❑ IRTF Internet Research Taskforce
- ❑ IS-IS Intermediate System to Intermediate System
- ❑ ISO International Standards Organization
- ❑ L2 Layer 2
- ❑ LACP Link Aggregation Control Protocol
- ❑ LAN Local Area Network
- ❑ LISP Locator-ID Separation Protocol
- ❑ LS Link State
- ❑ MAC Media Access Control
- ❑ MPLS Multi-protocol Label Switching
- ❑ NAT Network Address Translation
- ❑ NetIDE Network Interactive Development Environment
- ❑ NEMO File Manager for Linux Distribution

Student Questions

Acronyms (Cont)

- ❑ NFV Network Function Virtualization
- ❑ NTP Network Time Protocol
- ❑ NVGRE Network Virtualization using Generic Routing Encapsulation
- ❑ NVO3 Network Virtualization over L3
- ❑ NVP Network Virtualization Platform
- ❑ OF OpenFlow
- ❑ OnePK Open Network Environment Platform Kit
- ❑ ONF Open Networking Forum
- ❑ ONV OpenDaylight Network Virtualization
- ❑ OpEx Operational Expenses
- ❑ OS Operating System
- ❑ OSCP OpenDaylight SDN Controller Platform
- ❑ OSGi Open Services Gateway Initiative
- ❑ OSPF Open Shortest Path First
- ❑ OVS Open Virtual Switch
- ❑ OVSDB Open Virtual Switch Database

Student Questions

Acronyms (Cont)

- ❑ PCC Path Computation Client
- ❑ PCE Path Computation Element
- ❑ PCEP Path Computation Element Protocol
- ❑ POP Post Office Protocol
- ❑ PWE3 Pseudowire Emulation Edge to Edge
- ❑ QoS Quality of Service
- ❑ REST Representational State Transfer
- ❑ RFC Request for Comments
- ❑ RLOC Routing Locator
- ❑ RLOC Routing Locator
- ❑ RS Routing System
- ❑ SAL Service Abstraction Layer
- ❑ SDN Software Defined Networking
- ❑ SMTP Simple Mail Transfer Protocol
- ❑ SNMP Simple Network Management Protocol

Student Questions

Acronyms (Cont)

- ❑ SNMP4SDN SNMP for SDN
- ❑ SSH Secure Socket Host
- ❑ STT Stateless TCP-like Transport
- ❑ TCP Transmission Control Protocol
- ❑ TE Traffic Engineering
- ❑ TIA Telecom Industry Association
- ❑ TRILL Transparent Interconnection of Lots of Links
- ❑ URI Uniform Resource Identifier
- ❑ vBridge Virtual Bridge
- ❑ VIRL Virtual Internet Routing Lab
- ❑ VLAN Virtual Local Area Network
- ❑ VM Virtual Machine
- ❑ VNS Virtual Network Segement
- ❑ VPN Virtual Private Network
- ❑ vTep Virtual Tunnel End Point
- ❑ VTN Virtual Tenant Network

Student Questions

Acronyms (Cont)

- ❑ VxLAN Virtual Extensible Local Area Network
- ❑ WAN Wide Area Network
- ❑ XML Extensible Markup Language
- ❑ XMPP Extensible Messaging and Presence Protocol

Student Questions

Style Guide

Correct	Incorrect
ACL	Acl or acl
API	api
ARP	Arp or arp
IPsec	IPSEC or ipsec
IPv4 or IPv6	Ipv4, Ipv6, ipv4, ipv6, IPV4, or IPV6
Karaf	karaf
Linux	LINUX or linux
NETCONF	Netconf or netconf
Neutron	neutron
OSGi	osgi or OSGI
Open vSwitch	OpenvSwitch, OpenVSwitch, or Open V Switch.
OpenDaylight	Opendaylight, Open Daylight, or OpenDayLight.
OpenFlow	Openflow, Open Flow, or openflow.
OpenStack	Open Stack or Openstack
QoS	Qos, QOS, or qos
RESTCONF	Restconf or restconf
RPC	Rpc or rpc
URL	Url or url

Student Questions

Source: <http://docs.opendaylight.org/en/stable-nitrogen/documentation.html>

Washington University in St. Louis

<http://www.cse.wustl.edu/~jain/cse570-21/>

©2021 Raj Jain

SDN Related Organizations and Projects

- ❑ Linux Foundation Open Source Networking, <https://www.linuxfoundation.org/projects/networking/>
- ❑ Open Networking Foundation (ONF): www.opennetworking.org
- ❑ Telecom Industry Association (TIA): www.tiaonline.org
- ❑ European Telecommunications Standards Institute (ETSI): www.etsi.org/
- ❑ Association for Telecom Industry Solutions (ATIS): www.atis.org/topsc/sdn.asp
- ❑ Internet Engineering Task Force (IETF): www.ietf.org
- ❑ OpenStack Quantum: <https://wiki.openstack.org/wiki/Quantum>
- ❑ OpenDaylight: www.opendaylight.org

Student Questions

SDN Web Sites

- ❑ SDN Central, <http://www.sdncentral.com>
- ❑ SDN Open Source Projects,
<http://www.sdncentral.com/comprehensive-list-of-open-source-sdn-projects/>
- ❑ SDN Products and Services,
<http://www.sdncentral.com/announced-sdn-products/>
- ❑ HotSDN 2012, <http://yuba.stanford.edu/~casado/of-sw.html>
(Papers downloadable)
- ❑ SDN-OpenFlow Research and Projects,
<http://searchsdn.techtarget.com/resources/SDN-OpenFlow-research-and-projects>

Student Questions

Scan This to Download These Slides



Raj Jain

<http://rajjain.com>

Student Questions

http://www.cse.wustl.edu/~jain/cse570-21/m_15sdn.htm

Washington University in St. Louis

<http://www.cse.wustl.edu/~jain/cse570-21/>

©2021 Raj Jain

Related Modules



CSE567M: Computer Systems Analysis (Spring 2013),

https://www.youtube.com/playlist?list=PLjGG94etKypJEKjNAa1n_1X0bWWNyZcof

CSE473S: Introduction to Computer Networks (Fall 2011),

https://www.youtube.com/playlist?list=PLjGG94etKypJWOSPMh8Azcg5e_10TiDw



Wireless and Mobile Networking (Spring 2016),

https://www.youtube.com/playlist?list=PLjGG94etKypKeb0nzyN9tSs_HCd5c4wXF

CSE571S: Network Security (Fall 2011),

<https://www.youtube.com/playlist?list=PLjGG94etKypKvzfVtutHcPFJXumyyg93u>



Video Podcasts of Prof. Raj Jain's Lectures,

<https://www.youtube.com/channel/UCN4-5wzNP9-ruOzQMs-8NUw>

Student Questions