

Introduction to OpenFlow



Raj Jain
Washington University in Saint Louis
Saint Louis, MO 63130
Jain@cse.wustl.edu

These slides and audio/video recordings of this class lecture are at:

<http://www.cse.wustl.edu/~jain/cse570-23/>

Student Questions



1. Planes of Networking
2. OpenFlow
3. OpenFlow Operation
4. OpenFlow Switches, including Open vSwitch
5. OpenFlow Evolution
6. Current Limitations and Issues

Note: This is the first module of four modules on OpenFlow, OpenFlow Controllers, SDN, and NFV in this course.

Student Questions

Planes of Networking

- ❑ **Data Plane:** All activities involving as well as resulting from data packets sent by the end user, e.g.,
 - Forwarding
 - Fragmentation and reassembly
 - Replication for multicasting
- ❑ **Control Plane:** All activities that are necessary to perform data plane activities but do not involve end-user data packets
 - Making routing tables
 - Setting packet handling policies (e.g., security)
 - Base station beacons announcing the availability of services

Student Questions

Ref: Open Data Center Alliance Usage Model: Software Defined Networking Rev 1.0,”

http://www.opendatacenteralliance.org/docs/Software_Defined_Networking_Master_Usage_Model_Rev1.0.pdf

Planes of Networking (Cont)

- ❑ **Management Plane:** All activities related to provisioning and monitoring of the networks
 - Fault, Configuration, Accounting, Performance, and Security (**FCAPS**).
 - Instantiate new devices and protocols (Turn devices on/off)
 - Optional ⇒ May be handled manually for small networks.
- ❑ **Services Plane:** Middlebox services to improve performance or security, e.g.,
 - Load Balancers, Proxy Service, Intrusion Detection, Firewalls, SSL Off-loaders
 - Optional ⇒ Not required for small networks

Student Questions

- ❑ Are all four planes in layer 2.5?
The planes are not layered. The data plane includes all seven layers. Other planes are parallel to it.

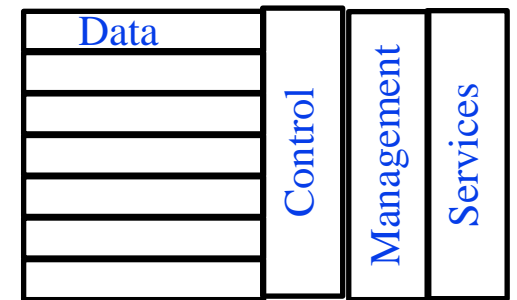

Data vs. Control Logic

- ❑ Data plane runs at a line rate,
e.g., 100 Gbps for 100 Gbps Ethernet \Rightarrow Fast Path
 \Rightarrow Typically implemented using special hardware,
e.g., Ternary Content Addressable Memories (TCAMs)
- ❑ Some exceptional data plane activities are handled by the CPU
in the switch \Rightarrow Slow path
e.g., Broadcast, Unknown, and Multicast (BUM) traffic
- ❑ All control activities are generally handled by the CPU

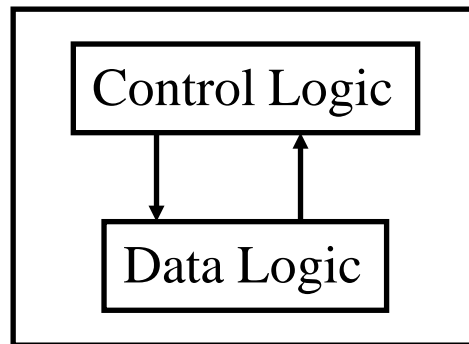

Student Questions

OpenFlow: Key Ideas

1. Separation of control and data planes
2. Centralization of control
3. Flow-based control

Student Questions

Ref: N. McKeown, et al., "OpenFlow: Enabling Innovation in Campus Networks," ACM SIGCOMM CCR, Vol. 38, No. 2, April 2008, pp. 69-74.

Washington University in St. Louis

<http://www.cse.wustl.edu/~jain/cse570-23/>

©2023 Raj Jain

Separation of Control and Data Plane

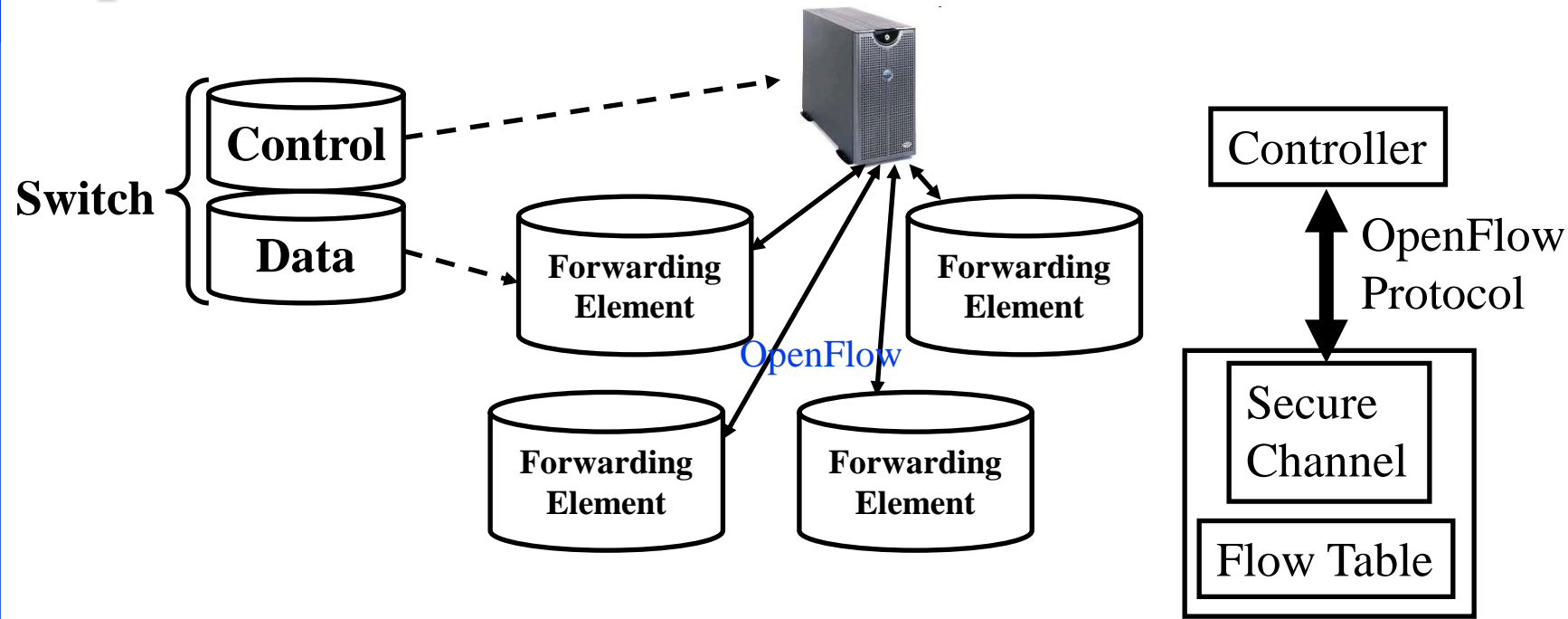

- ❑ Control logic is moved to a controller
- ❑ Switches only have forwarding elements
- ❑ One expensive controller with a lot of cheap switches
- ❑ OpenFlow is the protocol to send/receive forwarding rules from the controller to switches

Student Questions

- ❑ In this diagram, the controller at the top does all control logic and then relays it to switches that perform only data logic. This transfer of control logic is the OpenFlow protocol.

The protocol used to transfer is the OpenFlow protocol.

- ❑ The idea of OpenFlow is good, but isn't it hard to replace all the equipment to use OpenFlow? Because a company may have existing equipment.

Yes. OpenFlow can be used iff all switches in the LAN are OpenFlow. It is used in new data centers and networks.

OpenFlow V1.0

- On packet arrival, match the header fields with flow entries in a table; if any entry matches, update the counters indicated in that entry and perform indicated actions

Flow Table:

Header Fields	Counters	Actions
Header Fields	Counters	Actions
...
Header Fields	Counters	Actions

Ingress Port	Ether Source	Ether Dest	VLAN ID	VLAN Priority	IP Src	IP Dst	IP Proto	IP ToS	Src L4 Port	Dst L4 Port
--------------	--------------	------------	---------	---------------	--------	--------	----------	--------	-------------	-------------

Student Questions

Ref: <http://archive.openflow.org/documents/openflow-spec-v1.0.0.pdf>

Washington University in St. Louis

<http://www.cse.wustl.edu/~jain/cse570-23/>

©2023 Raj Jain

Flow Table Example

Port	Src MAC	Dst MAC	VLAN ID	Priority	EtherType	Src IP	Dst IP	IP Proto	IP ToS	Src L4 Port ICMP Type	Dst L4 Port ICMP Code	Action	Counter
*	*	0A:C8:*	*	*	*	*	*	*	*	*	*	Port 1	102
*	*	*	*	*	*	*	192.168.*.*	*	*	*	*	Port 2	202
*	*	*	*	*	*	*	*	*	*	21	21	Drop	420
*	*	*	*	*	*	*	*	0x806	*	*	*	Local	444
*	*	*	*	*	*	*	*	0x1*	*	*	*	Controller	1

- ❑ Idle timeout: Remove entry if no packets are received for this time
- ❑ Hard timeout: Remove entry after this time
- ❑ If both are set, the entry is removed if either expires.

Ref: S. Azodolmolky, "Software Defined Networking with OpenFlow," Packt Publishing, October 2013, 152 pp., ISBN:978-1-84969-872-6 (Safari Book)

Student Questions

- ❑ Can you please explain the difference between idle and hard timeout? *Sure*
- ❑ Since each control node and forwarding node needs to maintain many information flow tables, will there be some robustness problems?

Yes, things can be out of sync for a little while.

Matching

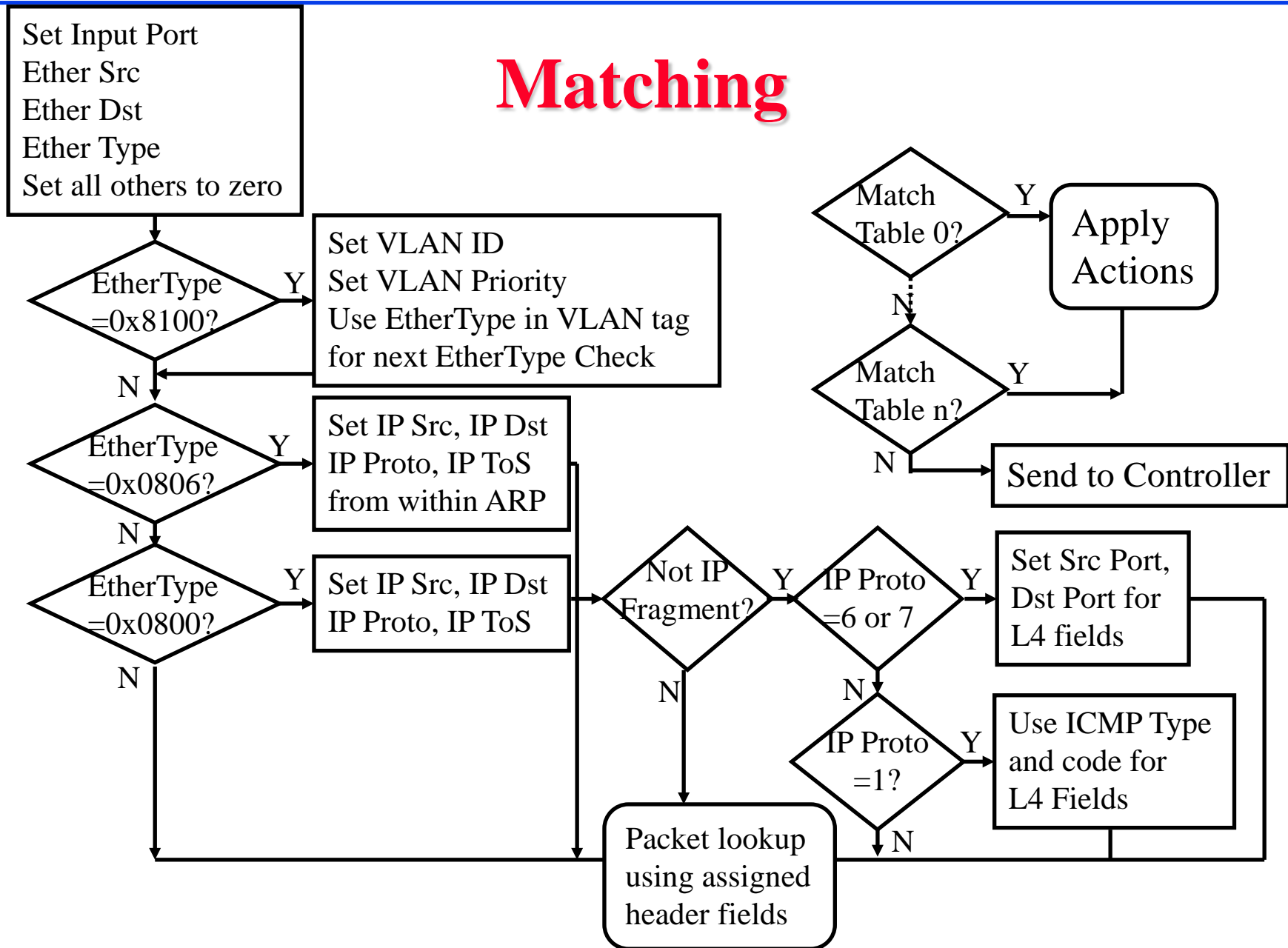

Student Questions

- Could you please explain this flow chart in detail again?
Sure.
- What's the difference between EtherType 0x0806 and 0x0800?
0x0806 is ARP, and 0x0800 is IP payload in an Ethernet frame.

Counters

Per Table	Per Flow	Per Port	Per Queue
Active Entries	Received Packets	Received Packets	Transmit Packets
Packet Lookups	Received Bytes	Transmitted Packets	Transmit Bytes
Packet Matches	Duration (Secs)	Received Bytes	Transmit overrun errors
	Duration (nanosecs)	Transmitted Bytes	
		Receive Drops	
		Transmit Drops	
		Receive Errors	
		Transmit Errors	
		Receive Frame Alignment Errors	
		Receive Overrun errors	
		Receive CRC Errors	
		Collisions	

Student Questions

Actions

- ❑ Forward to Physical Port i or to *Virtual Port*:
 - **All**: to all interfaces except the incoming interface
 - **Controller**: encapsulate and send to controller
 - **Local**: send to its local networking stack
 - **Table**: Perform actions in the flow table
 - **In_port**: Send back to input port
 - **Normal**: Forward using traditional Ethernet
 - **Flood**: Send along minimum spanning tree except for the incoming interface
- ❑ Enqueue: To a particular queue in the port \Rightarrow QoS
- ❑ Drop
- ❑ Modify Field: E.g., add/remove VLAN tags, ToS bits, Change TTL

Student Questions

- ❑ In "In_port," is this "input port" the same as "incoming interface" in "All"?

Yes.

Actions (Cont)

- ❑ Masking allows matching only selected fields, e.g., Dest. IP, Dest. MAC, etc.
- ❑ If a header matches an entry, corresponding actions are performed, and counters are updated
- ❑ If no header matches, the packet is queued, and the header is sent to the controller, which sends a new rule. Subsequent packets of the flow are handled by this rule.
- ❑ Secure Channel: Between the controller and the switch using TLS
- ❑ Modern switches already implement flow tables, typically using Ternary Content Addressable Memories (TCAMs)
- ❑ A controller can change the forwarding rules if a client moves
⇒ Packets for mobile clients are forwarded correctly
- ❑ A controller can send flow table entries beforehand (**Proactive**) or Send them on demand (**Reactive**). OpenFlow allows both models.

Student Questions

- ❑ When a packet doesn't match rules, we usually send it to the controller. So, we must wait some time to receive the corresponding rule. In the meantime, what do we do with the flow? Particularly, if the flow is an elephant flow, do we queue it somewhere?

Yes. All packets of that flow have to wait.

- ❑ For a controller, is it dedicated hardware or software that runs inside a switch?

Although it can be specialized hardware, a controller is generally a standard computer with controller software.

- ❑ Can you explain proactive and reactive in detail again?

Proactive = Find a solution before the problem happens

Reactive = Find a solution after the problem happens

OpenFlow Evolution Summary

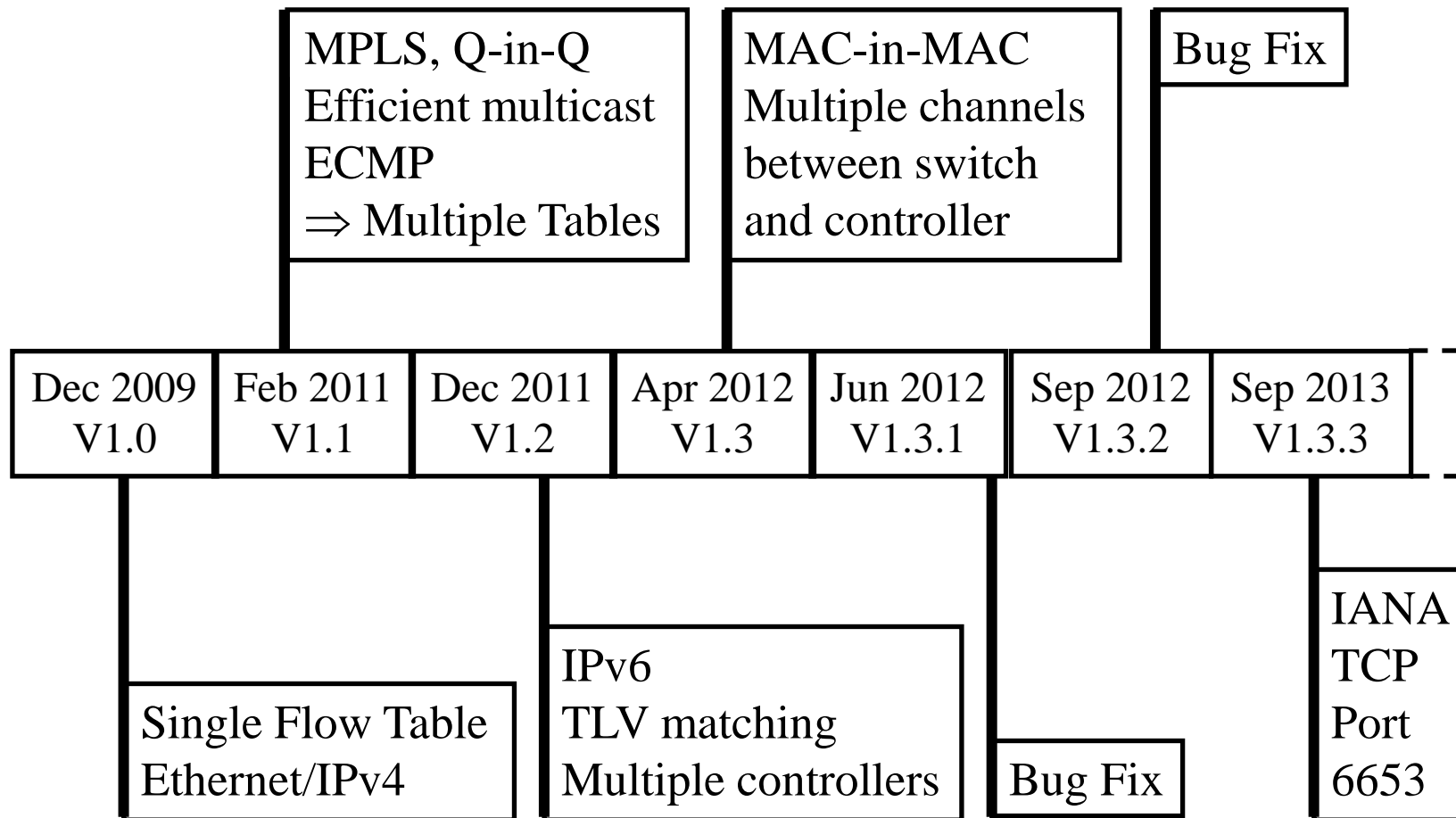

Student Questions

- ❑ Which kind of switch can use Openflow?
Any switches or specially designed switches? *Specially designed switches.*

OpenFlow Evolution Summary (Cont)

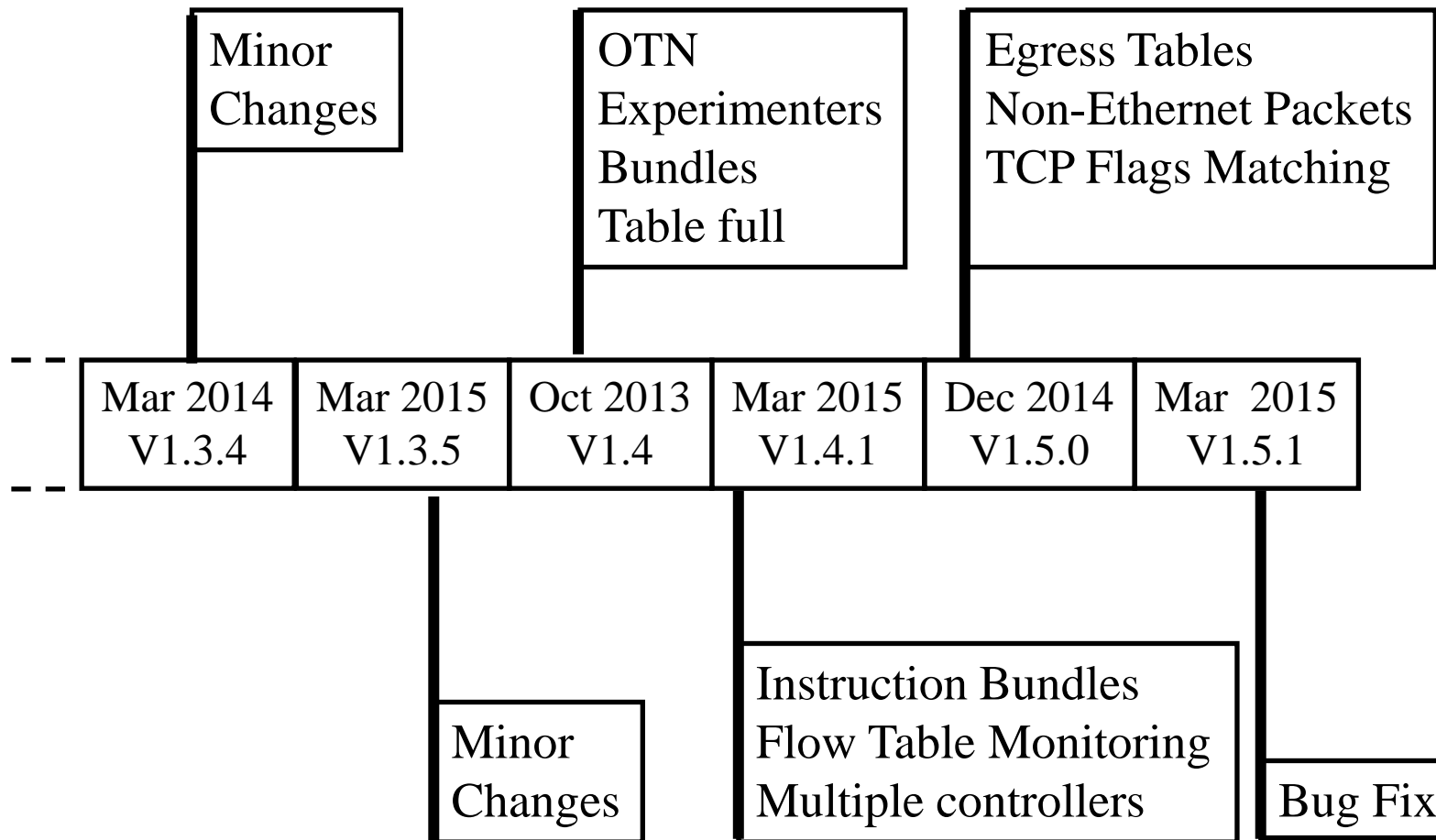

Student Questions

Bootstrapping

- ❑ Switches require initial configuration: Switch IP address, Controller IP address, Default gateway
- ❑ Switches connect to the controller
- ❑ The switch provides configuration information about ports
- ❑ The controller installs a rule to forward LLDP (Link Layer Discovery Protocol) packets to the controller and then sends, one by one, LLDP packets to be sent out to port I ($i=1, 2, \dots, n$), which are forwarded to respective neighbors. The neighbors send the packets back to the controller.
- ❑ The controller determines the topology from LLDP packets
- ❑ LLDP is a one-way protocol to advertise the capabilities at fixed intervals.

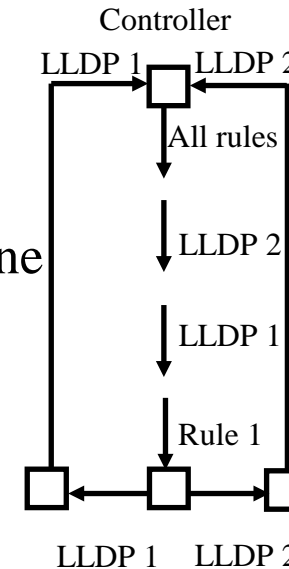

Student Questions

- ❑ Please explain bootstrapping more. Is it a control or data plane activity?
Bootstrapping is the “booting” process. It is a management plane activity.

Ref: S. Sharma, et al., “Automatic Bootstrapping of OpenFlow Networks,” 19th IEEE Workshop on LANMAN, 2013, pp. 1-6,
<http://ieeexplore.ieee.org/stamp/stamp.jsp?tp=&arnumber=6528283> (Available to subscribers only)

OpenFlow Configuration Protocol (OF-Config)

- ❑ **OpenFlow Configuration Point:** Entity that configures OpenFlow switches
- ❑ **OF-Config:** Protocol used for configuration and management of OpenFlow Switches.
Assignment of OF controllers so that switches can initiate connections to them:

- The IP address of the controller
- The port number at the controller
- Transport protocol: TLS or TCP
- Configuration of queues (min/max rates) and ports
- Enable/disable receive/forward speed, media on ports

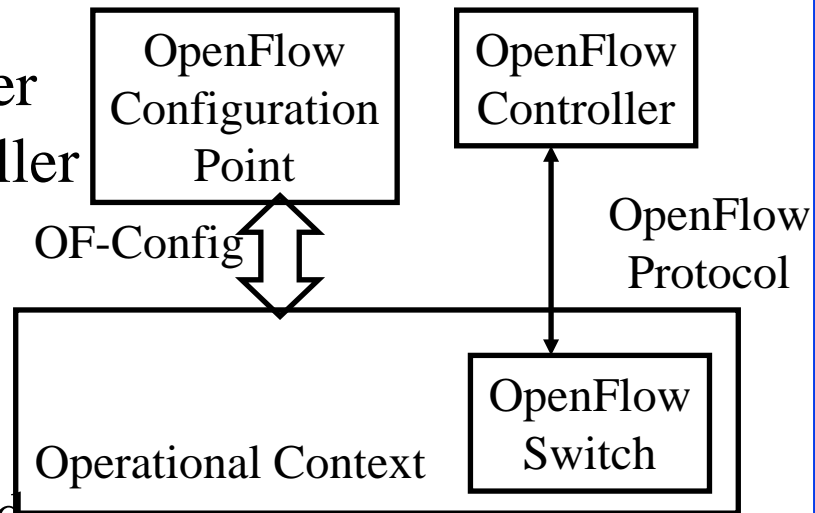

Student Questions

- ❑ What makes the OF Config point necessary in addition to the separation of function? It sounds like an OF controller can perform its function if it speaks OF-config protocol, e.g., sends a particular config packet that sets the transport protocol, config of queues, etc.

OF-Config is necessary if you have a large number of switches.

Ref: Cisco, "An Introduction to OpenFlow," Feb 2013,

http://www.cisco.com/web/solutions/trends/open_network_environment/docs/cisco_one_webcastan_introduction_to_openflowfebruary142013.pdf

Washington University in St. Louis

<http://www.cse.wustl.edu/~jain/cse570-23/>

©2023 Raj Jain

OF-Config (Cont)

- ❑ A physical switch = one or more **logical** switches each controlled by an OF Controller
- ❑ OF-Config allows the configuration of logical switches.

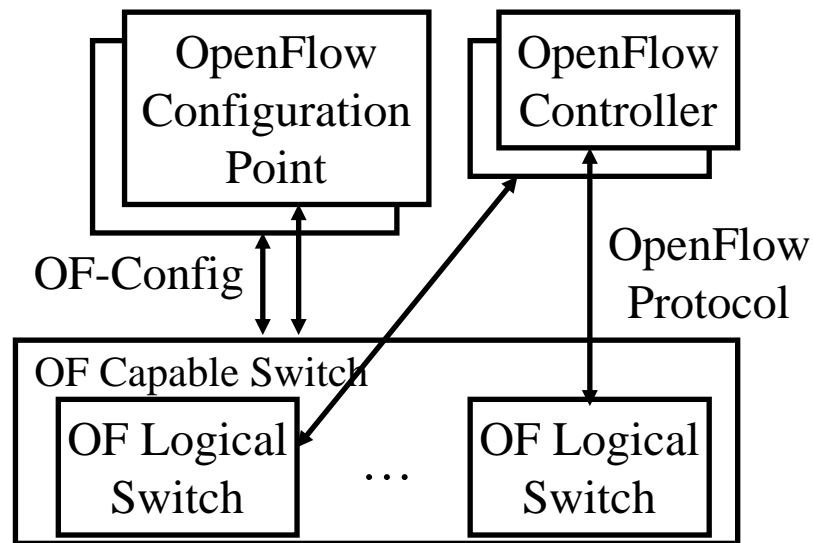

Student Questions

- ❑ Can one logical switch connect to multiple controllers?

No.

Ref: ONF, "OpenFlow Management and Configuration Protocol (OF-Config 1.1.1)," March 23, 2013,

<https://www.opennetworking.org/images/stories/downloads/sdn-resources/onf-specifications/openflow-config/of-config-1-1-1.pdf>

Washington University in St. Louis

<http://www.cse.wustl.edu/~jain/cse570-23/>

©2023 Raj Jain

OpenFlow Notification Framework

- ❑ **Notification:** Event-triggered messages, e.g., link down
- ❑ **Publish/subscribe model:** Switch = publisher. OpenFlow controller or OpenFlow config points, and others can subscribe. They will be notified about the events they subscribe to.
- ❑ Use **ITU-T M.3702** Notifications: Attribute value change, Communication alarm, Environmental alarm, Equipment alarm, QoS alarm, Processing error alarm, Security alarm, State change, Object creation, and deletion
- ❑ **Pre-existing Notifications:** Do not fit in the framework but will be recognized.
 - OpenFlow: Packet-in, Flow removed, Port Status, Error, Hello, Echo request, Echo reply, Experimenter
 - OpenFlow Config: OpenFlow logical switch instantiation, OpenFlow capability switch capability change, Successful OpenFlow session establishment, Failed OpenFlow session establishment, Port failure or recovery

Ref: <https://www.opennetworking.org/images/stories/downloads/sdn-resources/onf-specifications/openflow-config/of-notifications-framework-1.0.pdf>

Student Questions

Implementation Issues

- ❑ 40+ matching fields in a flow
- ❑ Multiple tables, each with a large number of flow entries
- ❑ Instructions and actions for each table
- ❑ Need VXLAN, NVGRE, etc. support
- ❑ For an extensive network, flow-level programming can take a long time
- ❑ Can't keep adding header fields \Rightarrow Move to P4 programming

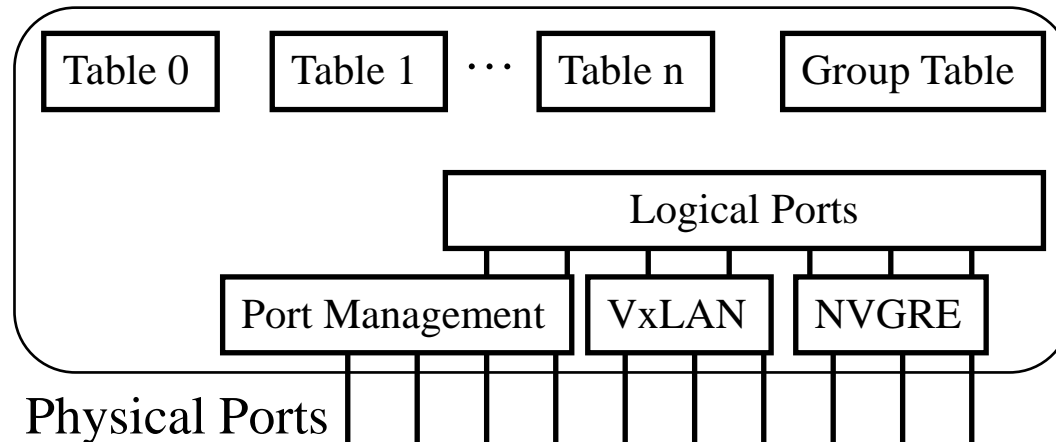

Ref: R. Oshana and S. Addepalli, "Networking Trends- Software Defined Networking, Network Virtualization and Cloud Orchestration," Asia Power Arch. Conf, Oct 2012, https://www.power.org/wp-content/uploads/2012/10/13.-FSL-SDN-Openflow-and-Cloud-computing-UPD_Rob-Oshana.pdf

Student Questions

P4 Language

- ❑ Programming **P**rotocol-Independent **P**acket **P**rocessors
- ❑ **Protocol-Independent**: Produces forwarding instructions for any L2-L5 protocol
- ❑ **Target Independent**: Programmers write one program that can run on many different hardware \Rightarrow A hw specific compiler translates the program to instructions for that hardware
 - Similar to how C program can run on any hardware
- ❑ **Reconfigurability**: Can change the program w/o changing the hardware

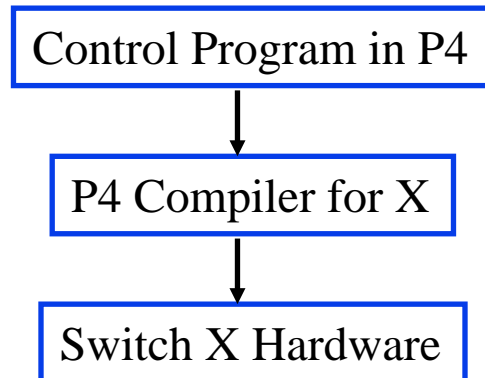

Ref: P. Bosshart, et al., “P4: Programming Protocol-Independent Packet Processors,” Computer Communication Review, ACM SIGCOMM, July 2014, 8 pp., <http://www.sigcomm.org/node/3503>

Student Questions

- ❑ Since they still have the academic paper coming out, are P4 and OpenFlow up to date in the networking right now?
OpenFlow is used sparingly, but SDN is in. The use of P4 has to be seen.

P4 Switch Design

- ❑ Packet parser: How to extract header fields, their names, and types
 - OpenFlow assumed a fixed parser and needed a new version for each new field
- ❑ Tables: Match and Action (similar to OpenFlow)
- ❑ Actions: Decrement Hop Count
 Forward packets to port three queue 4
- ❑ Some actions can be done in parallel, others sequential

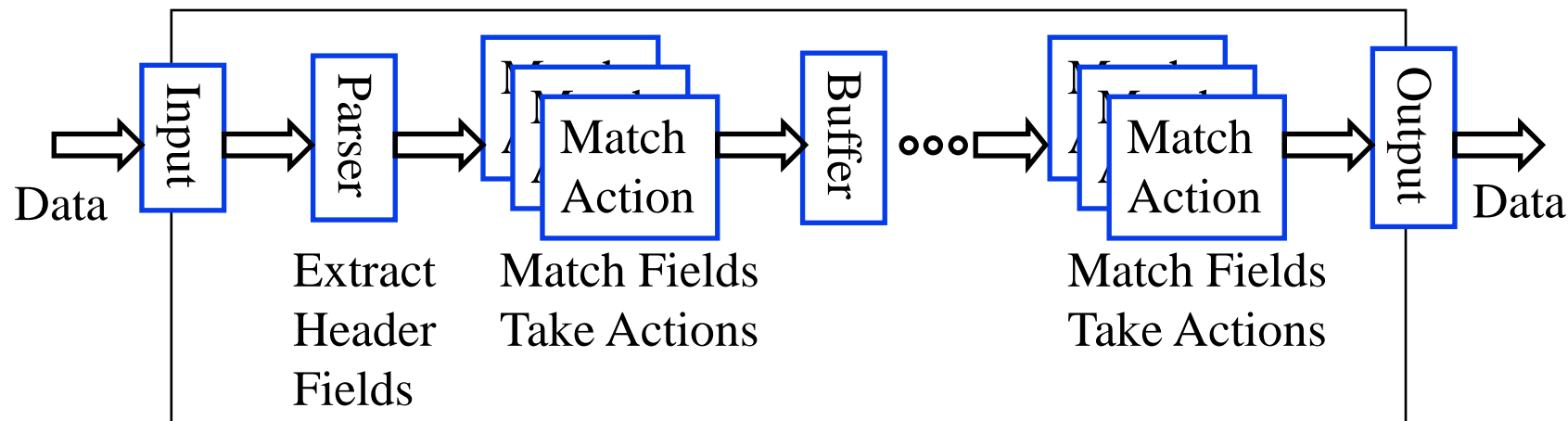

Student Questions

Open vSwitch

- ❑ Open Source Virtual Switch
- ❑ Nicira Concept
- ❑ It can Run as a stand-alone hypervisor switch or as a distributed switch across multiple physical servers
- ❑ Default switch in XenServer 6.0, Xen Cloud Platform and supported in Proxmox VE, VirtualBox, Xen KVM
- ❑ Integrated into many cloud management systems, including OpenStack, openQRM, OpenNebula, and oVirt
- ❑ Distributed with Ubuntu, Debian, and Fedora Linux. Also FreeBSD
- ❑ Intel has an accelerated version of Open vSwitch in its own Data Plane Development Kit (**DPDK**)

Ref: <http://openvswitch.org/>

Washington University in St. Louis

<http://www.cse.wustl.edu/~jain/cse570-23/>

©2023 Raj Jain

Student Questions

- ❑ What is the difference between this OpenvSwitch and the vSwitch concept we learned in the previous module?

Same.

Open vSwitch Features

- ❑ Link Aggregation Control Protocol (LACP)
- ❑ IEEE 802.1Q VLAN
- ❑ IEEE 802.1ag Connectivity Fault Management (CFM)
- ❑ Bidirectional Forwarding Detection (BFD) to detect link faults (RFC 5880)
- ❑ IEEE 802.1D-1998 Spanning Tree Protocol (STP)
- ❑ Per-VM traffic policing
- ❑ OpenFlow
- ❑ Multi-table forwarding pipeline
- ❑ IPv6
- ❑ GRE, VXLAN, IPSec tunneling
- ❑ Kernel and user-space forwarding engine options

Student Questions

OVSDB

- ❑ Open vSwitch Database Management Protocol (OVSDB)
- ❑ Monitoring capability using publish-subscribe mechanisms
- ❑ Stores both provisioning and operational state
- ❑ Java Script Object Notation (JSON) is used for schema format and JSON-RPC over TCP for wire protocol (RFC 4627)

<database-schema>

“name”: <id>

“version”: <version>

“tables”: {<id>: <table-schema>, ... }

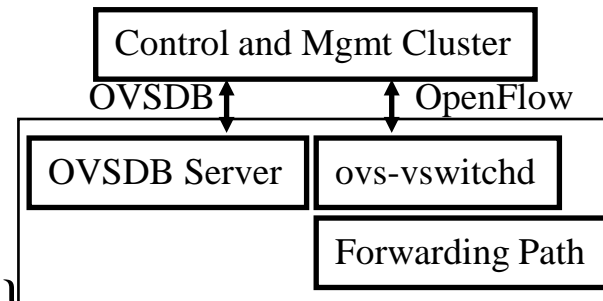

- ❑ RPC Methods: List databases, Get Schema, Update, Lock, ...
- ❑ Open vSwitch project includes open-source OVSDB client and server implementations

Ref: B. Pfaff and B. Davie, “The Open vSwitch Database Management Protocol,” IETF RFC 7047m December 2013,
<https://tools.ietf.org/pdf/rfc7047>

Student Questions

Summary



1. Four planes of Networking: Data, Control, Management, Service
2. OpenFlow separates the control plane and moves it to a central controller \Rightarrow Simplifies the forwarding element
3. Switches match incoming packets with flow entries in a table and handle it as instructed. The controller supplies the flow tables and other instructions.
4. OpenFlow has been extended to IPv4, MPLS, IPv6, and Optical Network. But more work is ahead.
5. Many hardware and software-based switches, including Open vSwitch

Student Questions

Reading List

Any one book:

- ❑ T. Nadeau and K. Gray, “SDN,” O’Reilly, 2013, 384 pp, ISBN:978-1-449-34230-2B (Safari Book)
- ❑ Oswald Coker, Siamak Azodolmolky, "Software-Defined Networking with OpenFlow - Second Edition," Packt Publishing, October 2017, 246 pp., ISBN:978-1-78398-429-9 (Safari Book).
- ❑ William Stallings, "Foundations of Modern Networking: SDN, NFV, QoE, IoT, and Cloud," Addison-Wesley Professional, October 2015, 544 pp., ISBN:0-13-417539-5 (Safari Book).
- ❑ Kingston Smiler. S, "OpenFlow Cookbook," Packt Publishing, April 2015, 292 pp., ISBN:978-1-78398-795-5 (Safari Book).
- ❑ P. Bosshart et al., “P4: Programming Protocol-Independent Packet Processors,” Computer Communication Review, ACM SIGCOMM, July 2014, 8 pp., <http://www.sigcomm.org/node/3503>

Student Questions

References

- ❑ N. McKeown et al., "OpenFlow: Enabling Innovation in Campus Networks," ACM SIGCOMM CCR, Vol. 38, No. 2, April 2008, pp. 69-74.
- ❑ ONF, "The OpenFlow Timeline," http://openflownetworks.com/of_timeline.php
- ❑ Open Data Center Alliance Usage Model: Software Defined Networking Rev 1.0," http://www.opendatacenteralliance.org/docs/Software_Defined_Networking_Master_Usage_Model_Rev1.0.pdf
- ❑ R. Oshana and S. Addepalli, "Networking Trends- Software Defined Networking, Network Virtualization and Cloud Orchestration," Asia Power Arch. Conf, Oct 2012, https://www.power.org/wp-content/uploads/2012/10/13.-FSL-SDN-Openflow-and-Cloud-computing-UPD_Rob-Oshana.pdf
- ❑ ONF, **Technical Library** (includes all OpenFlow, OF-Config, and other specifications), <https://www.opennetworking.org/sdn-resources/technical-library>

Student Questions

References (Cont)

- ❑ <http://www.openvswitch.org/>
- ❑ <http://www.projectfloodlight.org/indigo/>
- ❑ <http://flowforwarding.github.io/LINC-Switch/>
- ❑ <http://github.com/CPqD/openflow-openwrt>
- ❑ <http://cpqd.github.io/ofsoftswitch13/>
- ❑ <http://sourceforge.net/projects/xorplus>

Student Questions

Wikipedia Links

- ❑ <http://en.wikipedia.org/wiki/OpenFlow>
- ❑ http://en.wikipedia.org/wiki/Software-defined_networking
- ❑ http://en.wikipedia.org/wiki/Network_Functions_Virtualization
- ❑ http://en.wikipedia.org/wiki/Forwarding_plane
- ❑ [https://en.wikipedia.org/wiki/P4_\(programming_language\)](https://en.wikipedia.org/wiki/P4_(programming_language))

Student Questions

Wikipedia Links (Optional)

- ❑ <http://en.wikipedia.org/wiki/NetFlow>
- ❑ http://en.wikipedia.org/wiki/IP_Flow_Information_Export
- ❑ <http://en.wikipedia.org/wiki/SFlow>
- ❑ http://en.wikipedia.org/wiki/Northbound_interface
- ❑ http://en.wikipedia.org/wiki/Big_Switch_Networks
- ❑ http://en.wikipedia.org/wiki/Open_Data_Center_Alliance
- ❑ http://en.wikipedia.org/wiki/Virtual_Extensible_LAN
- ❑ http://en.wikipedia.org/wiki/Optical_Transport_Network
- ❑ http://en.wikipedia.org/wiki/Automatically_switched_optical_network
- ❑ http://en.wikipedia.org/wiki/Wavelength-division_multiplexing
- ❑ http://en.wikipedia.org/wiki/IEEE_802.1ad
- ❑ http://en.wikipedia.org/wiki/Transport_Layer_Security
- ❑ <http://en.wikipedia.org/wiki/OpenStack>
- ❑ http://en.wikipedia.org/wiki/IPv6_packet
- ❑ <http://en.wikipedia.org/wiki/ICMPv6>
- ❑ http://en.wikipedia.org/wiki/Multiprotocol_Label_Switching

Student Questions

Acronyms

- ❑ ACL Access Control List
- ❑ API Application Programming Interface
- ❑ ARP Address Resolution Protocol
- ❑ ASICs Application Specific Integrated Circuit
- ❑ BFD Bidirectional Forwarding Detection
- ❑ BUM Broadcast, Unknown, and Multicast
- ❑ CFM Connectivity Fault Management
- ❑ CPU Central Processing Unit
- ❑ DFCA Dynamic Frequency Channel Allocation
- ❑ DSCP Differentiated Service Control Point
- ❑ ECMP Equal Cost Multipath
- ❑ ESP Encrypted Security Payload
- ❑ FCAPS Fault, Configuration, Accounting, Performance and Security
- ❑ GRE Generic Routing Encapsulation
- ❑ ICMP Internet Control Message Protocol
- ❑ ID Identifier

Student Questions

Acronyms (Cont)

- ❑ IDS Intrusion Detection System
- ❑ IEEE Institution of Electrical and Electronic Engineers
- ❑ IETF Internet Engineering Task Force
- ❑ IGMP Internet Group Multicast Protocol
- ❑ IP Internet Protocol
- ❑ IPFIX IP Flow Information Export Protocol
- ❑ IPSec IP Security
- ❑ IPv4 Internet Protocol version 4
- ❑ IPv6 Internet Protocol version 6
- ❑ JSON Java Script Object Notation
- ❑ KVM Kernel-based Virtual Machine
- ❑ LACP Link Aggregation Control Protocol
- ❑ LLDP Link Layer Discovery Protocol
- ❑ MAC Media Access Control
- ❑ MAN Metropolitan Area Network
- ❑ MPLS Multiprotocol Label Switching

Student Questions

Acronyms (Cont)

- ❑ NFV Network Function Virtualization
- ❑ NVGRE Network Virtualization using Generic Routing Encapsulation
- ❑ OF OpenFlow
- ❑ ONF Open Networking Foundation
- ❑ openQRM Open Clusters Resource Manager
- ❑ OpenWRT Open WRT54G (Linksys product name) software
- ❑ OSPF Open Shortest Path First
- ❑ OTN Optical Transport Network
- ❑ OVSDB Open vSwitch Database
- ❑ P4 Programming Protocol-Independent Packet Processors
- ❑ PIM-SM Protocol Independent Multicast - Sparse Mode
- ❑ PIM Protocol Independent Multicast
- ❑ QoS Quality of Service
- ❑ RAN Radio area networks
- ❑ RFC Request for Comments
- ❑ RIP IGMP, IPv6, PIM-SM
- ❑ RIP Routing Information Protocol

Student Questions

Acronyms (Cont)

- ❑ RPC Remote Procedure Call
- ❑ RSPAN Remote Switch Port Analyzer
- ❑ SDN Software Defined Network
- ❑ SPAN Switch Port Analyzer
- ❑ SSL Secure Socket Layer
- ❑ STP Spanning Tree Protocol
- ❑ TCAM Ternary Content Addressable Memory
- ❑ TCP Transmission Control Protocol
- ❑ TLS Transport Level Security
- ❑ TLV Type-Length-Value
- ❑ ToS Type of Service
- ❑ TTL Time to Live
- ❑ TTP Table Typing Patterns
- ❑ UDP User Datagram Protocol
- ❑ VLAN Virtual Local Area Network
- ❑ VM Virtual Machine
- ❑ VxLAN Virtual Extensible Local Area Network
- ❑ WG Working Group

Student Questions

Scan This to Download These Slides



Raj Jain

<http://rajjain.com>

http://www.cse.wustl.edu/~jain/cse570-23/m_14ofl.htm

Student Questions

Related Modules



CSE567M: Computer Systems Analysis (Spring 2013),

https://www.youtube.com/playlist?list=PLjGG94etKypJEKjNAa1n_1X0bWWNyZcof

CSE473S: Introduction to Computer Networks (Fall 2011),

https://www.youtube.com/playlist?list=PLjGG94etKypJWOSPMh8Azcg5e_10TiDw



Wireless and Mobile Networking (Spring 2016),

https://www.youtube.com/playlist?list=PLjGG94etKypKeb0nzyN9tSs_HCd5c4wXF

CSE571S: Network Security (Fall 2011),

<https://www.youtube.com/playlist?list=PLjGG94etKypKvzfVtutHcPFJXumyyg93u>



Video Podcasts of Prof. Raj Jain's Lectures,

<https://www.youtube.com/channel/UCN4-5wzNP9-ruOzQMs-8NUw>

Student Questions