

# Mobile IP

## Part I: IPv4

Raj Jain

Professor of Computer Science and Engineering  
Washington University in Saint Louis  
Saint Louis, MO 63130

Audio/Video recordings of this lecture are available at:

<http://www.cse.wustl.edu/~jain/cse574-10/>



- ❑ Mobile IP: Terminology
- ❑ Processes: Registration, Advertisements, ..
- ❑ Security Issues
- ❑ Reverse Tunneling
- ❑ Home Networks with Dynamic IP Address
- ❑ Dynamic Home Agent Assignment
- ❑ Network Mobility (NEMO)
- ❑ Mobile IP and VPN

# Mobile IP: Features

- ❑ You can take your notebook to any location
- ❑ Your TCP connection can continue. TCP connections are from one IP address to another IP address  
⇒ TCP is unaware of the mobility
- ❑ Continuous access to your home resources
- ❑ Access to local resources: Printers
- ❑ Finds nearby IP routers and connects *automatically*
- ❑ Your IP messages are delivered to your new location
- ❑ Only "Mobility Aware" routers and mobile units need new s/w
- ❑ Other routers and hosts can use current IP
- ❑ No new IP address formats.
- ❑ Secure: Allows authentication

# Mr. Smith Goes to Washington

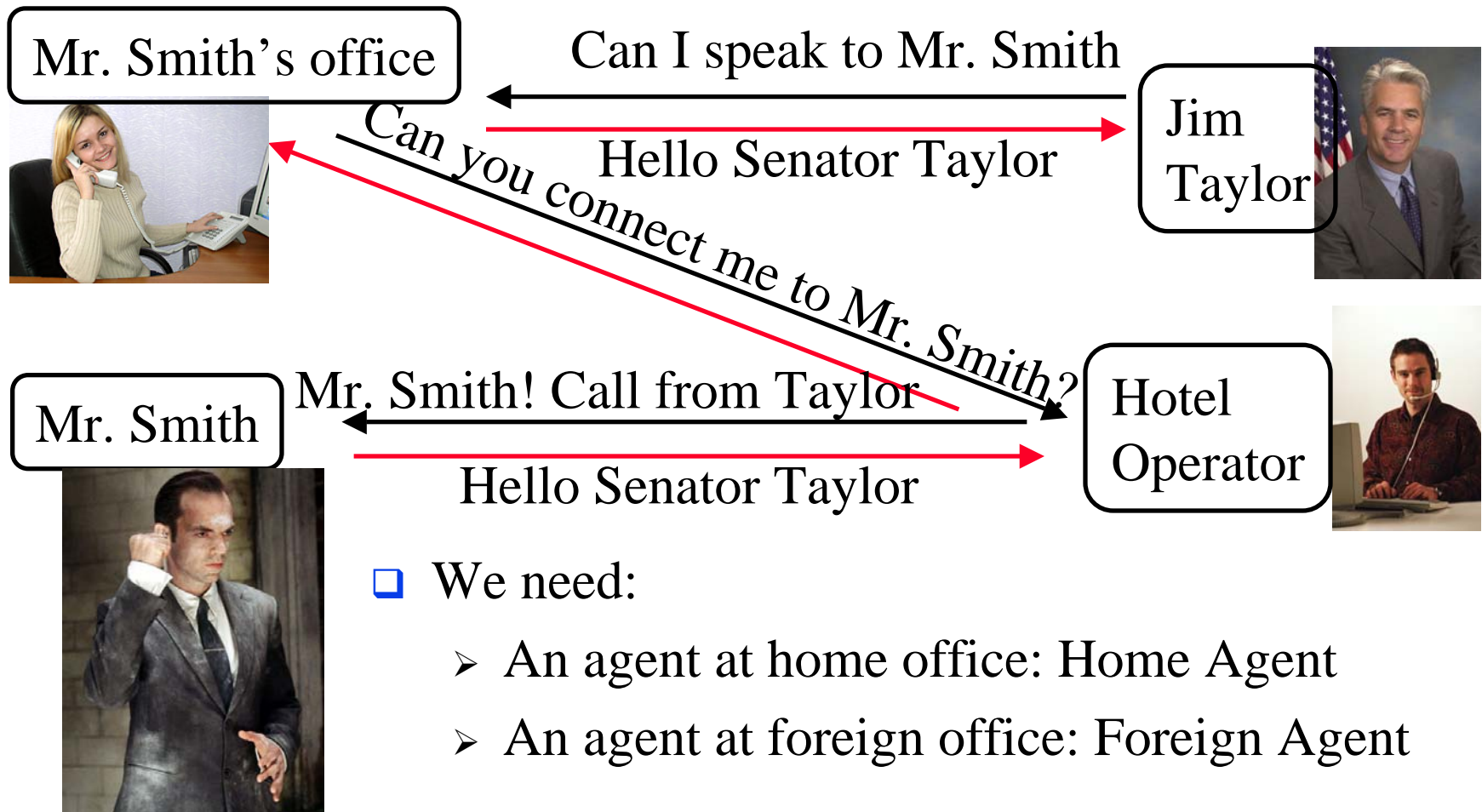

- We need:
  - An agent at home office: Home Agent
  - An agent at foreign office: Foreign Agent

# Mobile IP: Terminology

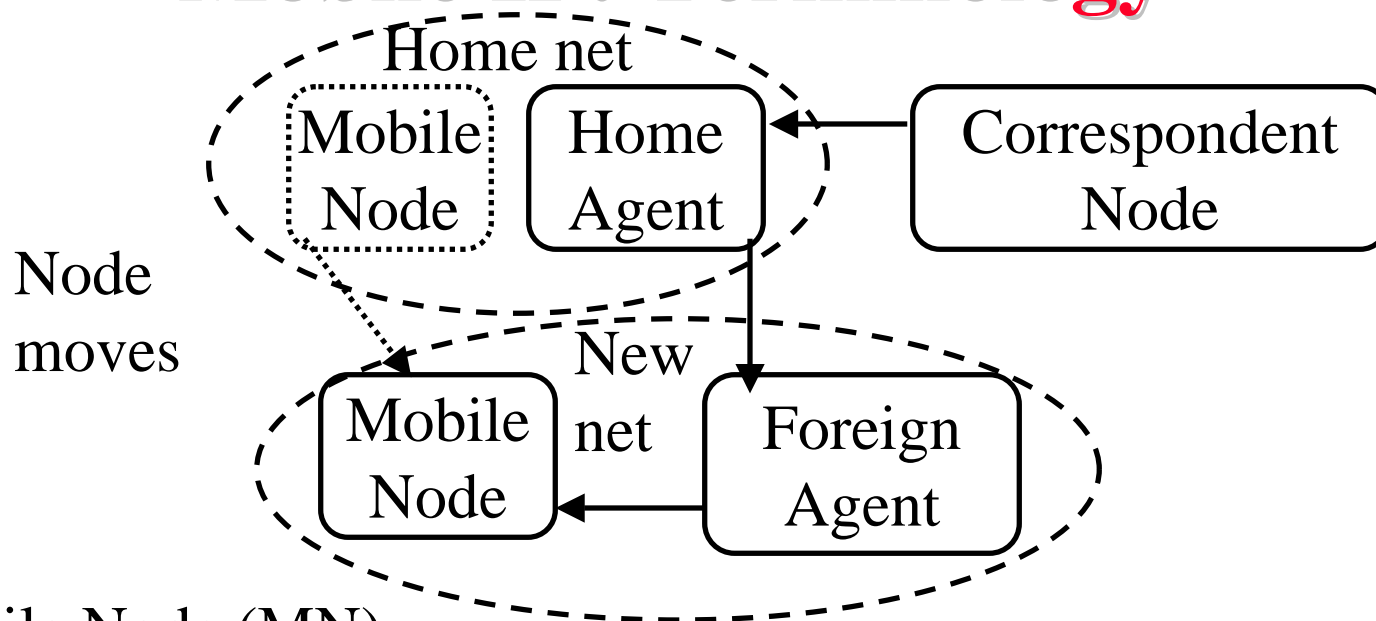

- ❑ Mobile Node (MN)
- ❑ Home Agent (HA), Foreign Agent (FA)
- ❑ Care-of-address (COA): Address of the end-of-tunnel towards the mobile node
- ❑ Correspondent Node (CN)
- ❑ Home Address: Mobile's permanent IP address

# Terminology

- ❑ **Home Address:** Long-term IP address of the mobile on the home network
- ❑ **IP Access Address:** Local IP address of the mobile on the foreign network
- ❑ **Care-of-Address:** Address to which the packets are sent by the home agent. Destination of the IP tunnel between home agent and the mobile. Generally COA=IP Access Address
- ❑ **Mobility Agent:** Home agent or foreign agent
- ❑ **Agent Advertisement:** Periodic advertisement from mobility agents
- ❑ **Correspondent Node:** The node communicating with mobile
- ❑ **Foreign Network:** Any network other than the home network
- ❑ **Gratuitous ARP:** Sent by home agent to update other node's ARP cache

## Terminology (Cont)

- ❑ **Mobility Binding:** Binding between home address and COA
- ❑ **Tunnel:** Path followed by an encapsulated packet
- ❑ **Mobile Router:** A router with changing point of attachment
- ❑ **Mobile Host:** A end host (not a router)
- ❑ **Mobile Node:** Mobile Host or Mobile Router
- ❑ **Mobile Network:** An entire network that changes its point of attachment
- ❑ **Mobile Network Node:** A node in a mobile network. May itself be mobile (visiting) or fixed (permanent) member of the network.
- ❑ **Roaming:** Getting connectivity from a foreign network based on a formal agreement between foreign and home network service providers

## Terminology (Cont)

- ❑ **Handover:** Changing the point of attachment
- ❑ **L2 Handover:** Moving from one access point to another access point in the same IP network (same network prefix)
- ❑ **L3 Handover:** Moving from one IP network to another.  
Moving from one access router to another access router
- ❑ **Horizontal Handover:** Moving between same technology.  
WLAN to WLAN or 3G to 3G
- ❑ **Vertical Handover:** Moving between different technologies.  
WLAN to 3G.
- ❑ **Push Handover:** Previous access router initiates handover
- ❑ **Pull Handover:** New access router initiates handover



## Terminology (Cont)

- ❑ **Make-Before-Break:** Make a new connection before disconnecting previous. Will communicate with both for some time.
- ❑ **Break-before-Make:** Disconnect previous and then connect with next.
- ❑ **Handover Delay:** Time between break and make.
- ❑ **Smooth Handover:** Minimize packet loss. Handover delay not critical.
- ❑ **Fast Handover:** Minimize handover delay. Packet loss not critical.
- ❑ **Seamless Handover:** No change in quality, security, or capability of service.

## Terminology (Cont)

- ❑ **Diversity**: Ability to receive two signals at the same time.
- ❑ **Micro Diversity**: Two signals between the same subscriber and base station
- ❑ **Macro Diversity**: Two signals from different base stations
- ❑ **IP Diversity**: Packets from two IP networks
- ❑ **Micro Mobility**: Mobility within a single network. No effect outside the network. a.k.a. Local Mobility.
- ❑ **Macro Mobility**: Mobility between networks. Requires Mobile IP type solution. a.k.a. Global Mobility.

# Mobile IP: Processes

## □ **Agent Discovery:** To find agents

- Home agents and foreign agents advertise periodically on network layer and optionally on datalink
- They also respond to solicitation from mobile node
- Mobile can send solicitation to Mobile agent multicast group 224.0.0.11
- Mobile selects an agent and gets/uses care-of-address

## □ **Registration**

- Mobile registers its care-of-address with home agent. Either directly or through foreign agent
- Home agent sends a reply to the CoA
- Each "Mobility binding" has a negotiated lifetime limit
- To continue, reregister within lifetime

## Processes (Cont)

- ❑ **Return to Home:**
  - Mobile node deregisters with home agent  
sets care-of-address to its permanent IP address
  - Lifetime = 0  $\Rightarrow$  Deregistration
- ❑ Deregistration with foreign agents is not required.  
Expires automatically
- ❑ Simultaneous registrations with more than one COA  
allowed (for handoff)

# Encapsulation/Tunneling

- ❑ Home agent intercepts mobile node's datagrams and forwards them to care-of-address
- ❑ Care of Address can be the Foreign Agent or it can be co-located in the mobile host
- ❑ Home agent tells local nodes and routers to send mobile node's datagrams to it
- ❑ De-encapsulation: Datagram is extracted and sent to mobile node



# Reverse Tunneling

- ❑ Normally, MN sends the packets directly to the correspondent with SA=Home Address, DA=Correspondent
- ❑ Problem: Such packets may be dropped by visited network's firewalls since the source address is not on foreign network
- ❑ Solution: Reverse traffic is also sent via home agent [RFC 3024]

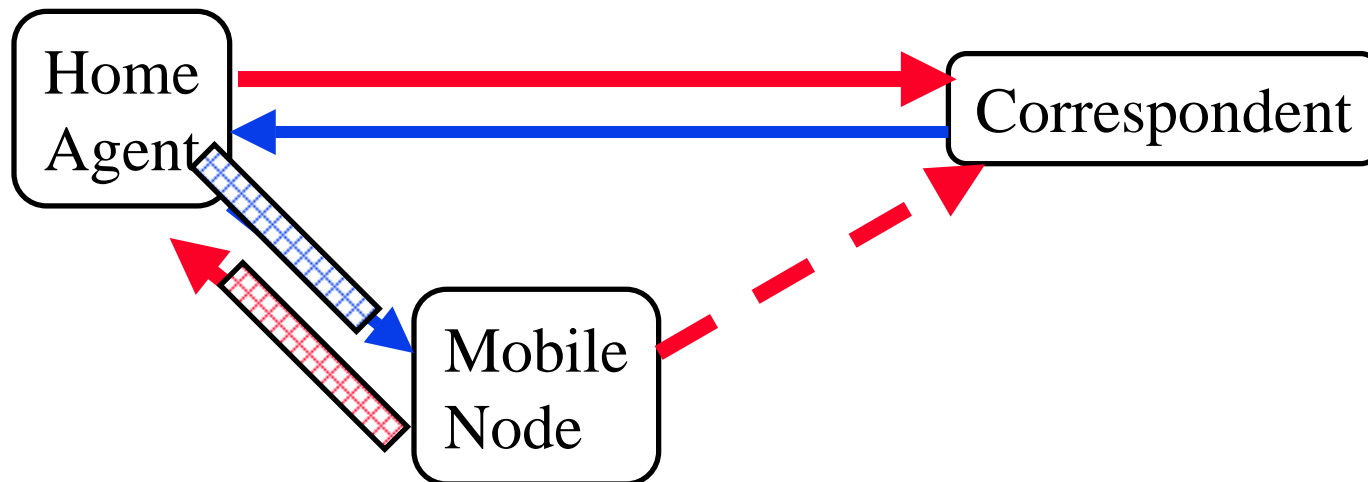

## Home Networks with Dynamic IP Address

- ❑ Problem: DHCP based hosts do not have the initial IP address, DNS address on the home network
- ❑ Cisco's Solution: The registration request to home agent includes a request for configuration
- ❑ The registration reply includes IP address, DHCP server's address, DNS address
- ❑ RFC 4332, Cisco's Mobile IPv4 Host Configuration Extensions

# Dynamic Home Agent Assignment

- ❑ Dynamic HA extension allows home agents to be assigned dynamically. Based on load balancing or other considerations.
- ❑ Example: Using CoA at foreign agent [RFC 4433]

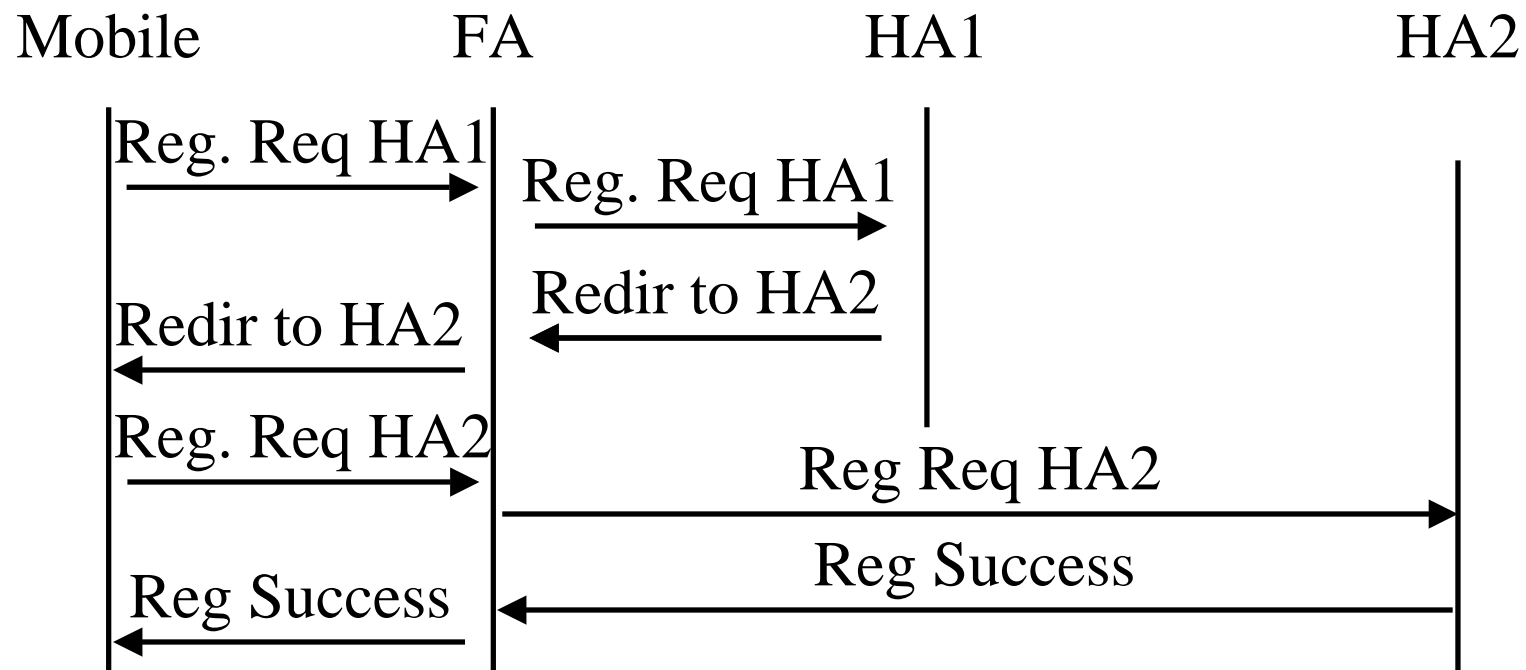



# Network Mobility (NEMO)

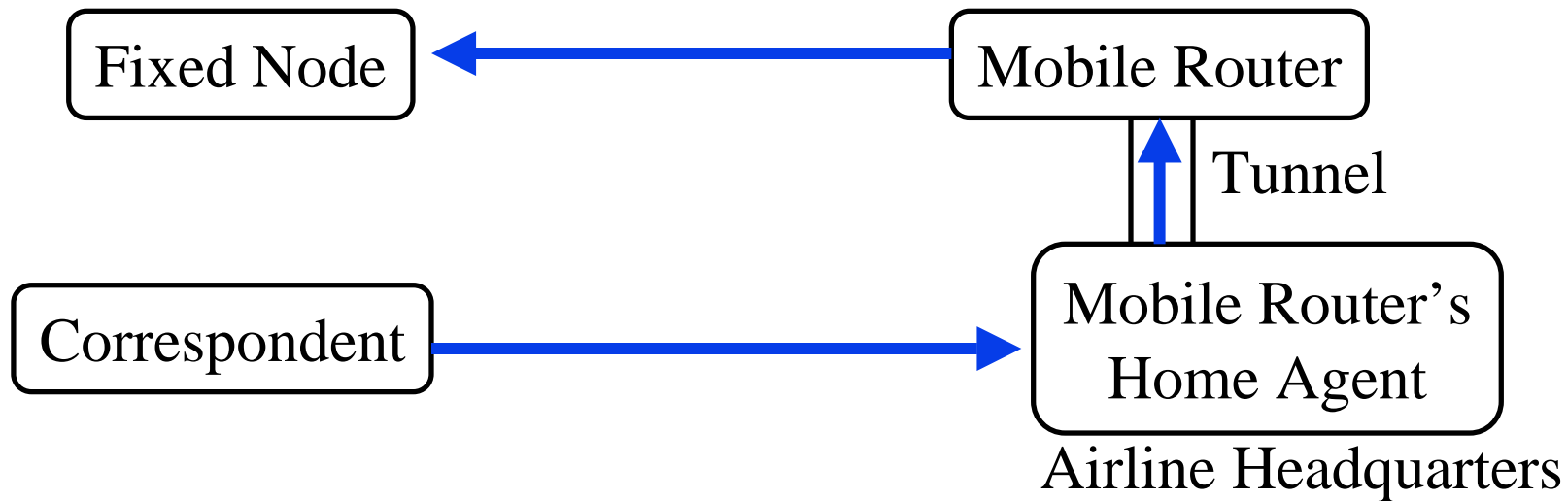

- ❑ Mobile router registers “network prefixes” with home agent
- ❑ All addresses with those prefixes are forwarded by home agent to Mobile router in a tunnel
- ❑ The reverse traffic is also tunneled.
- ❑ The mobile network may have visiting mobile routers or visiting mobile nodes.

❑ RFC 3963, Jan 2005

# Security Issues

- ❑ Need to Authenticate: MN – FA, FA-HA, MN-HA
- ❑ Message Authentication Code: Use keyed-MD5
- ❑ Key Management: Need network key distribution
- ❑ Confidentiality: Use encryption IPsec ESP
- ❑ Replay Protection: Changing Identification field. Use time stamps as ID or Nonces
- ❑ Location Privacy: Reverse traffic is tunneled via HA
- ❑ Ingress Filtering: Firewalls drop outgoing packets with topologically incorrect source address  
⇒ Use reverse tunneling with COA as SA

# Mobile IP and VPN

- ❑ Mobile IP  $\Rightarrow$  MIPv4 tunnel between Care-of-Address and Home Agent. COA at Foreign agent or co-located in Mobile.
- ❑ VPN  $\Rightarrow$  IPsec Tunnel between Mobile and VPN Gateway
- ❑ Depending upon the location of home agent:
  - IPsec inside MIPv4 tunnel or MIPv4 inside IPsec tunnel
- ❑ RFC 4093 lists five possible locations for Home Agent
- ❑ Work in progress to modify Mobile IP for VPN

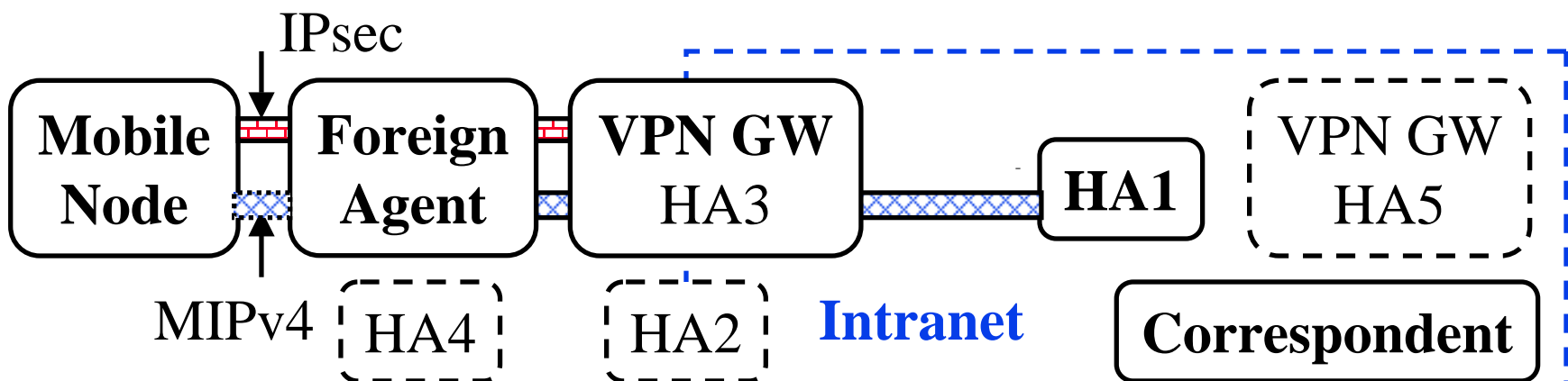

# Mobile IP and VPN (Cont)

## 1. Home Agent inside Intranet: MIP inside IPsec.

Foreign agent cannot be COA.

Co-located COA only.

Every COA change  $\Rightarrow$  New VPN tunnel

This is the most common configuration

$\Rightarrow$  Requires modifications to MIPv4

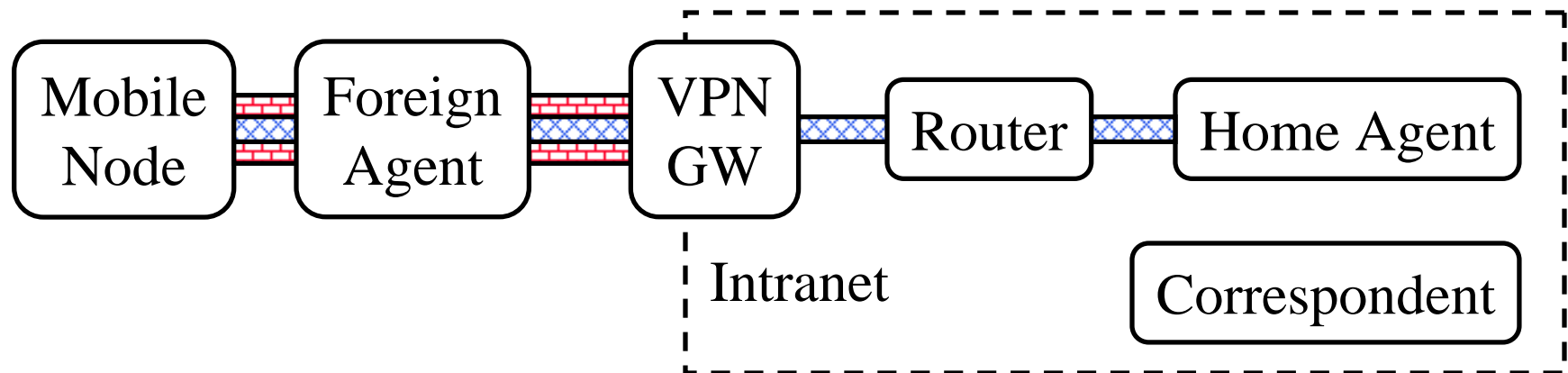

## Mobile IP and VPN (Cont)

### 5. Combined VPN Gateway and HA in the Intranet:

This works without any problems or modifications.

IPsec in MIPv4

Not scalable to thousands of mobile users

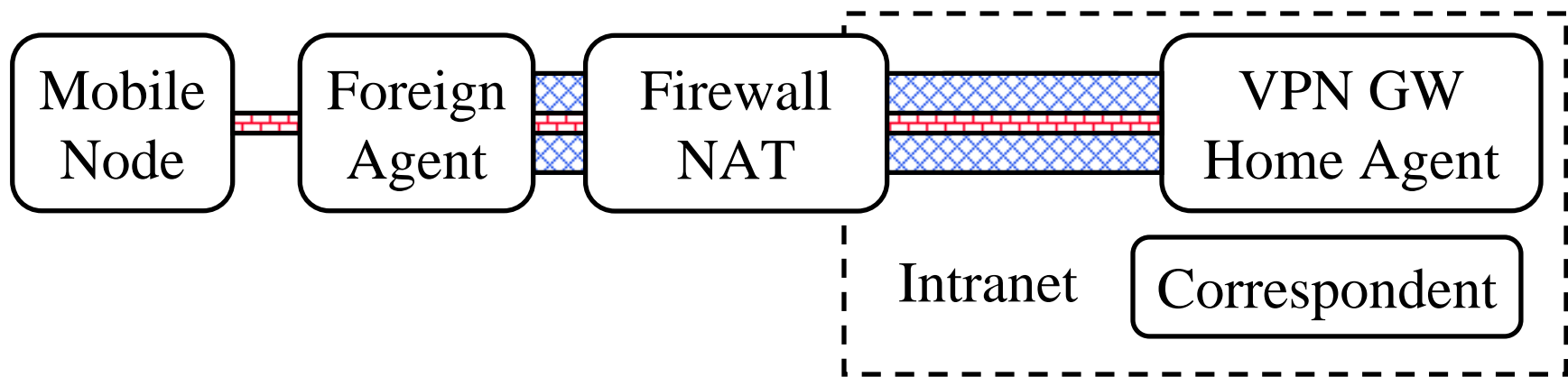

# Summary

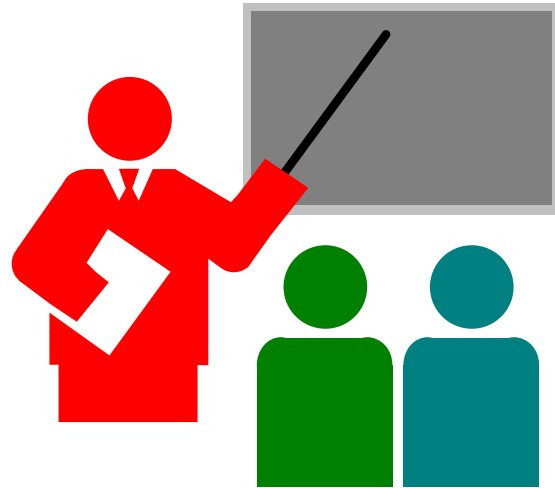

- ❑ Mobile node gets its packet via a tunnel from the home agent to care-of-address
- ❑ Reverse tunnel from mobile to home agent is optional
- ❑ It is possible to dynamically assign home address and home agents
- ❑ Network mobility is supported. Requires reverse tunneling.
- ❑ Need to carefully position VPN gateway and home agents for proper nesting of IPsec and Mobile-IP tunnels

## Related Wikipedia Articles

- ❑ [http://en.wikipedia.org/wiki/Mobile\\_IP](http://en.wikipedia.org/wiki/Mobile_IP)
- ❑ [http://en.wikipedia.org/wiki/Care-of\\_address](http://en.wikipedia.org/wiki/Care-of_address)
- ❑ [http://en.wikipedia.org/wiki/Encapsulation\\_\(networking\)](http://en.wikipedia.org/wiki/Encapsulation_(networking))
- ❑ [http://en.wikipedia.org/wiki/Triangular\\_routing](http://en.wikipedia.org/wiki/Triangular_routing)
- ❑ [http://en.wikipedia.org/wiki/Flat\\_IP#Flat\\_IP\\_Architectures\\_in\\_Mobile\\_Networks:\\_From\\_3G\\_to\\_LTE](http://en.wikipedia.org/wiki/Flat_IP#Flat_IP_Architectures_in_Mobile_Networks:_From_3G_to_LTE)
- ❑ [http://en.wikipedia.org/wiki/Generic\\_Routing\\_Encapsulation](http://en.wikipedia.org/wiki/Generic_Routing_Encapsulation)
- ❑ [http://en.wikipedia.org/wiki/IP\\_in\\_IP](http://en.wikipedia.org/wiki/IP_in_IP)
- ❑ [http://en.wikipedia.org/wiki/IP\\_tunnel](http://en.wikipedia.org/wiki/IP_tunnel)

# Reading Assignment

## Text Books:

- ❑ Dixit and Prasad, Chapter 16, pp. 335-439.
- ❑ Murthy and Manoj, Section 4.3, pp. 158-172

## IETF Working Group:

<http://www.ietf.org/html.charters/OLD/mobileip-charter.html>

## Other Papers:

- ❑ Y. Chen, “A Survey Paper on Mobile IP,”  
[http://www.cse.wustl.edu/~jain/cis788-95/mobile\\_ip/index.html](http://www.cse.wustl.edu/~jain/cis788-95/mobile_ip/index.html)
- ❑ Charlie Perkins, “Mobile IP,” IEEE Communications Magazine, May 2002, pp. 66-82 (also May 1997 pp.84-99)



# References: Mobile IPv4 RFCs

## Key RFCs:

- ❑ RFC 2005 "Applicability Statement for IP Mobility Support," October 1996.
- ❑ RFC 3344 "IP Mobility Support for IPv4," August 2002.
- ❑ RFC 4988 "Mobile IPv4 Fast Handovers," October 2007.
- ❑ RFC 3024 "Reverse Tunneling for Mobile IP, revised," January 2001.
- ❑ RFC 4433 "Mobile IPv4 Dynamic Home Agent (HA) Assignment," March 2006.
- ❑ RFC 4093 "Problem Statement: Mobile IPv4 Traversal of Virtual Private Network (VPN) Gateways," August 2005.

# References: Mobile IPv4 RFCs (Cont)

## Secondary RFCs:

- ❑ RFC 2006 "The Definitions of Managed Objects for IP Mobility Support using SMIPv2," October 1996.
- ❑ RFC 2290 "Mobile-IPv4 Configuration Option for PPP IPCP," February 1998.
- ❑ RFC 2356 "Sun's SKIP Firewall Traversal for Mobile IP," June 1998.
- ❑ RFC 2794 "Mobile IP Network Access Identifier Extension for IPv4," March 2000.
- ❑ RFC 2977 "Mobile IP Authentication, Authorization, and Accounting Requirements," October 2000.
- ❑ RFC 3115 "Mobile IP Vendor/Organization-Specific Extensions," April 2001.

## References: Mobile IPv4 RFCs (Cont)

- ❑ RFC 3519 "Mobile IP Traversal of Network Address Translation (NAT) Devices," May 2003.
- ❑ RFC 3543 "Registration Revocation in Mobile IPv4," August 2003.
- ❑ RFC 3583 "Requirements of a Quality of Service (QoS) Solution for Mobile IP," September 2003.
- ❑ RFC 3846 "Mobile IPv4 Extension for Carrying Network Access Identifiers," June 2004.
- ❑ RFC 3957 "Authentication, Authorization, and Accounting (AAA) Registration Keys for Mobile IPv4," March 2005.
- ❑ RFC 4004 "Diameter Mobile IPv4 Application," August 2005.
- ❑ RFC 4064 "Experimental Message, Extensions, and Error Codes for Mobile IPv4," May 2005.

## References: Mobile IPv4 RFCs (Cont)

- ❑ RFC 4332 "Cisco's Mobile IPv4 Host Configuration Extensions," December 2005.
- ❑ RFC 4636 "Foreign Agent Error Extension for Mobile IPv4," October 2006.
- ❑ RFC 4721 "Mobile IPv4 Challenge/Response Extensions (Revised)," January 2007.
- ❑ RFC 4728 "The Dynamic Source Routing Protocol (DSR) for Mobile Ad Hoc Networks for IPv4," February 2007.
- ❑ RFC 4784 "Verizon Wireless Dynamic Mobile IP Key Update for cdma2000(R) Networks," June 2007.
- ❑ RFC 4857 "Mobile IPv4 Regional Registration," June 2007.
- ❑ RFC 4881 "Low-Latency Handoffs in Mobile IPv4," June 2007.

## References: Mobile IPv4 RFCs (Cont)

- ❑ RFC 4908 "Multi-homing for small scale fixed network Using Mobile IP and NEMO," June 2007.
- ❑ RFC 4917 "Mobile IPv4 Message String Extension," June 2007.
- ❑ RFC 5030 "Mobile IPv4 RADIUS Requirements," October 2007.
- ❑ RFC 5159, "Session Description Protocol (SDP) Attributes for Open Mobile Alliance (OMA) Broadcast (BCAST) Service and Content Protection," March 2008.
- ❑ RFC 5177, "Network Mobility (NEMO) Extensions for Mobile IPv4," April 2008.
- ❑ RFC 5265, "Mobile IPv4 Traversal across IPsec-Based VPN Gateways," June 2008.
- ❑ RFC 5266, "Secure Connectivity and Mobility Using Mobile IPv4 and IKEv2 Mobility and Multihoming (MOBIKE)," June 2008.
- ❑ RFC 5446, "Service Selection for Mobile IPv4," February 2009.
- ❑ RFC 5454, "Dual-Stack Mobile IPv4," March 2009

# IETF Wireless Related Activities

- ❑ Mobile Ad-hoc Networks (manet),  
<http://www.ietf.org/html.charters/manet-charter.html>
- ❑ IPv6 over Low power WPAN (6lowpan),  
<http://www.ietf.org/html.charters/6lowpan-charter.html>
- ❑ Routing Over Low power and Lossy networks (roll),  
<http://www.ietf.org/html.charters/roll-charter.html>
- ❑ Ospf-wireless-design -- OSPF Wireless Design Team,  
<https://www.ietf.org/mailman/listinfo/ospf-wireless-design>

# Homework 18

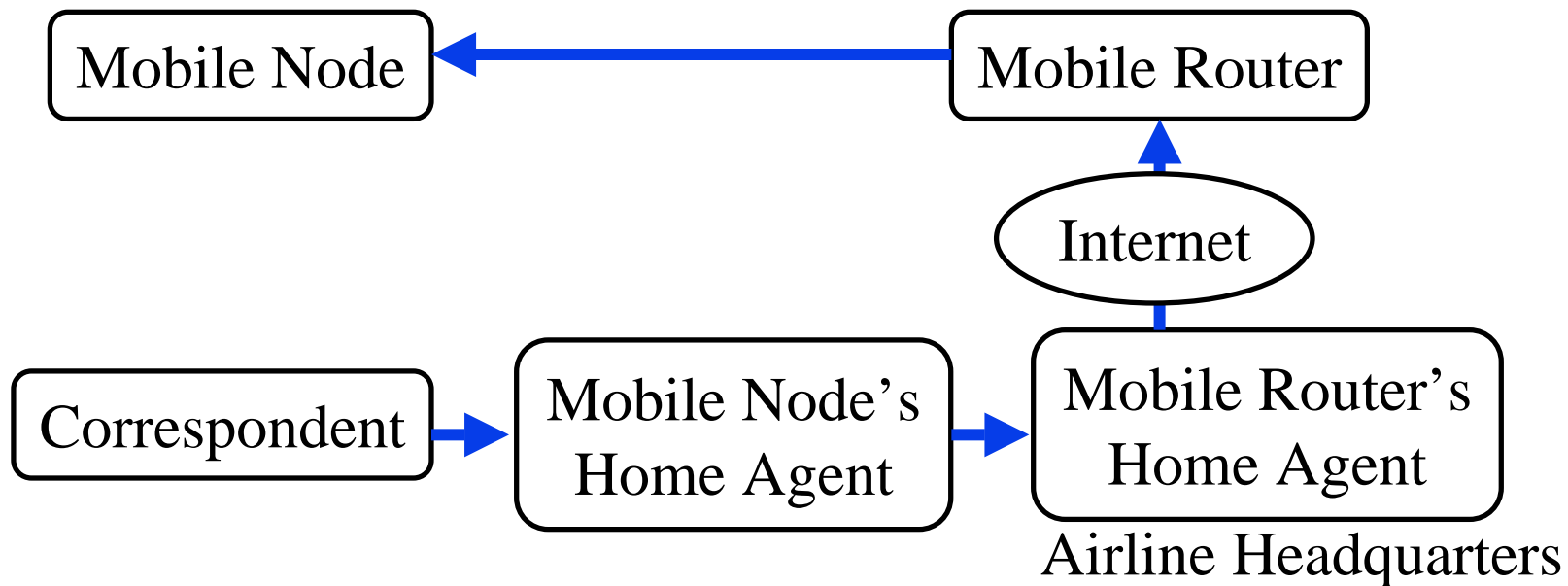
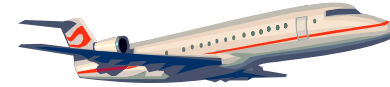

- A mobile node with home address in WUSTL.EDU is traveling in a plane with a router that serves as COA . But the router itself is mobile and has a home address at AA.COM. How many Mobile IP tunnels will be setup and indicate IP addresses of the end points of each tunnel. Hint: See RFC3344.

# List of Acronyms

- ❑ ARP           Address Resolution Protocol
- ❑ CN            Correspondent Node
- ❑ COA           Care-of Address
- ❑ DHCP          Dynamic Host Control Protocol
- ❑ HA            Home Agent
- ❑ ID            Identifier
- ❑ IETF          Internet Engineering Task Force
- ❑ IP            Internet Protocol
- ❑ IPSEC        Secure Internet Protocol
- ❑ IPv4          Internet Protocol Version 4
- ❑ IPv6          Internet Protocol Version 6
- ❑ MN            Mobile Node
- ❑ NEMO         Network Mobility
- ❑ OSPF         Open Shortest Path First



## List of Acronyms (Cont)

- ❑ RFC Request for Comments
- ❑ SPI Security parameter index
- ❑ TCP Transmission Control Protocol
- ❑ VPN Virtual Private Network
- ❑ WLAN Wireless Local Area Network