

Introduction to 5G



Raj Jain
Washington University in Saint Louis
Saint Louis, MO 63130
Jain@cse.wustl.edu

Slides and Audio/Video recordings of this class lecture are available at:

<http://www.cse.wustl.edu/~jain/cse574-16/>



1. What: 5G Definition
2. How:
 1. New Radio Multiplexing Technologies
 2. New Efficient Spectrum Usage Techniques
 3. New Energy Saving Mechanisms
 4. CapEx/OpEx Reduction Techniques
 5. New Spectrum
 6. Application Specific Improvements

Note: This is the 4th module in a series of lectures on 2G/3G, LTE, LTE-Advanced, and 5G

5G Definition

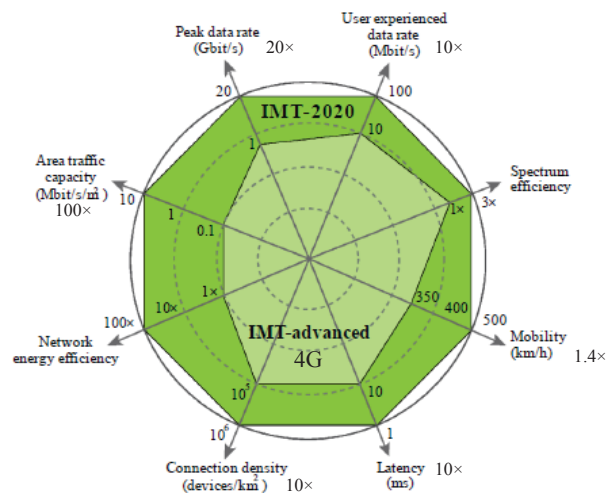

Ref: ITU-R Recommendation M.2083-0, "IMT Vision – Framework and overall objectives of the future development of IMT for 2020 and beyond," Sep. 2015, 21 pp., https://www.itu.int/dms_pubrec/itu-r/rec/m/R-REC-M.2083-0-201509-1!PDF-E.pdf

5G Definition (Cont)

1. Peak Data Rate: max rate per user under ideal conditions. 10 Gbps for mobiles, 20 Gbps under certain conditions.
2. User experienced Data Rate: Rate across the coverage area per user. 100 Mbps in urban/suburban areas. 1 Gbps hotspot.
3. Latency: Radio contribution to latency between send and receive
4. Mobility: Max speed at which seamless handover and QoS is guaranteed
5. Connection Density: Devices per km²
6. Energy Efficiency: Network bits/Joule, User bits/Joule
7. Spectrum Efficiency: Throughput per Hz per cell
8. Area Traffic Capacity: Throughput per m²

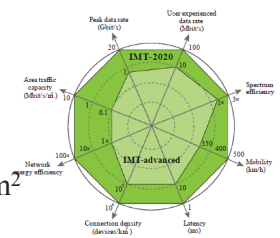

Importance

- ❑ Three Key Application Areas:
 - Enhanced Mobile Broadband
 - Ultra-Reliable and Low Latency: Real-time, safety
 - Massive Machine Type Communications

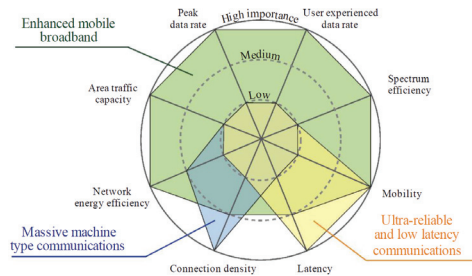

Ref: ITU-R Recommendation M.2083-0, "IMT Vision – Framework and overall objectives of the future development of IMT for 2020 and beyond," Sep. 2015, 21 pp., https://www.itu.int/dms_pubrec/itu-r/rec/m/R-REC-M.2083-0-201509-1!!PDF-E.pdf
Washington University in St. Louis <http://www.cse.wustl.edu/~jain/cse574-16/>

©2016 Raj Jain

19-5

Timeline

- ❑ 3G: IMT-2000 started in 1985, first release in 2000
- ❑ 4G: IMT-Advanced, vision in 2003, First release in 2012
- ❑ 5G: IMT-2020, vision in 2015, first release in 2020

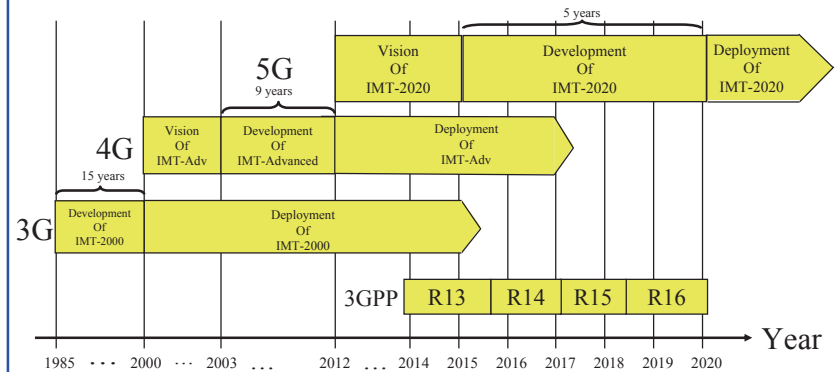

Ref: ITU-R, "Workplan, timeline, process and deliverables for the future development of IMT," 4pp., Washington University in St. Louis <http://www.cse.wustl.edu/~jain/cse574-16/>

©2016 Raj Jain

19-6

How?

1. New Radio Multiplexing Technologies
2. New Efficient Spectrum Usage Techniques
3. New Energy Saving Mechanisms
4. CapEx/OpEx Reduction Techniques
5. New Spectrum
6. Application Specific Improvements

Washington University in St. Louis <http://www.cse.wustl.edu/~jain/cse574-16/>

©2016 Raj Jain

19-7

New Radio Multiplexing Technologies

1. Spectrum Filtered OFDM (f-OFDM)
2. Filtered Bank Multicarrier (FBMC)
3. Non-Orthogonal Multiple Access (NOMA)
4. Pattern Division Multiple Access (PDMA)
5. Low Density Spreading (LDS)
6. Sparse Code Multiple Access (SCMA)
7. Interleave-Division Multiple Access (IDMA)

Washington University in St. Louis <http://www.cse.wustl.edu/~jain/cse574-16/>

©2016 Raj Jain

19-8

Problems with OFDM

- ❑ Spectrum overflow \Rightarrow Need **guard bands**
- ❑ Entire band should use the **same subcarrier** spacing
- ❑ Entire time should use the **same symbol size** and cyclic prefix
- ❑ All users should strictly **time synchronize** in the uplink

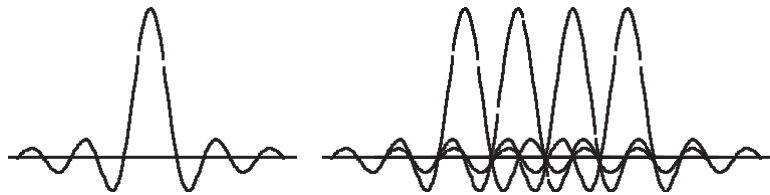

Ref: P. Zhu, "5G Enabling Technologies," PIMRC, Sep 2014, 20 slides, http://www.ieee-pimrc.org/2014/2014-09-03%205G%20Enabling%20Technologies%20PMIRC%20Huawei_Final.pdf
 Washington University in St. Louis <http://www.cse.wustl.edu/~jain/cse574-16/> ©2016 Raj Jain

19-9

Spectrum Filtered OFDM (f-OFDM)

- ❑ Band divided into multiple subbands
- ❑ Each subband may use different OFDM parameters optimized for the application: Frequency spacing, cyclic prefix, ...
- ❑ Each subband spectrum is **filtered** to avoid inter-subband interference \Rightarrow Spectrum filtered
- ❑ Different users (subbands) do not need to be time synchronized \Rightarrow **Asynchronous OFDMA**

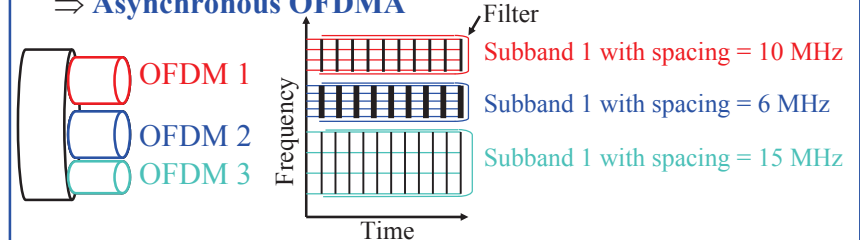

Ref: P. Zhu, "5G Enabling Technologies," PIMRC, Sep 2014, 20 slides, http://www.ieee-pimrc.org/2014/2014-09-03%205G%20Enabling%20Technologies%20PMIRC%20Huawei_Final.pdf
 Washington University in St. Louis <http://www.cse.wustl.edu/~jain/cse574-16/> ©2016 Raj Jain

19-10

Filtered Bank Multicarrier (FBMC)

- ❑ A filter is used to remove the subcarrier overflow
- ❑ No side lobes \Rightarrow No cyclic prefix needed \Rightarrow More bits/Hz
- ❑ Different users can have different subbands with different parameters

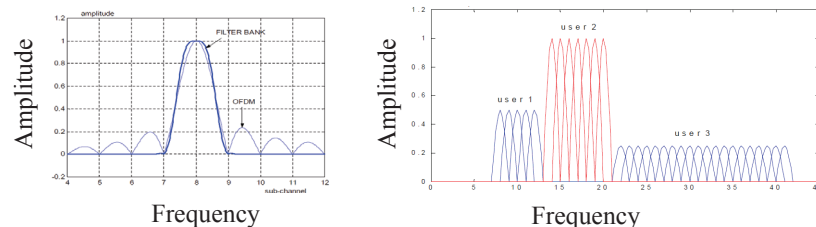

Ref: M. Bellanger, "FBMC physical layer – principle," June 2011, 13 slides, [http://www.cept.org/Documents/se-43/500/SE43\(11\)Info06_FBMC-physical-layer-principle](http://www.cept.org/Documents/se-43/500/SE43(11)Info06_FBMC-physical-layer-principle)
 Washington University in St. Louis <http://www.cse.wustl.edu/~jain/cse574-16/> ©2016 Raj Jain

19-11

Non-Orthogonal Multiple Access (NOMA)

- ❑ Users are distinguished by power levels
- ❑ Users with poor channel condition get higher power
- ❑ Users with higher power decode their signal treating others as noise
- ❑ Users with lower power subtract the higher powered signals before decoding
- ❑ Can also be used with beamforming and MIMO

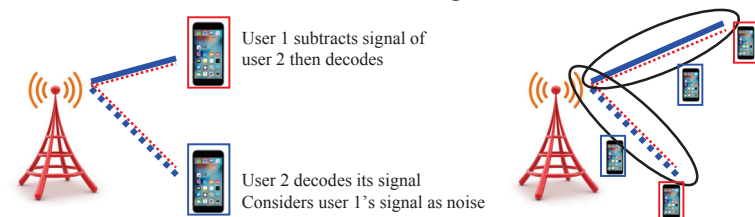

Ref: G. Ding, et al, "Application of Non-orthogonal Multiple Access in LTE and 5G Networks," <https://pdfs.semanticscholar.org/a404/21a9762db528bfe848166765fee43e740c94.pdf>
 Washington University in St. Louis <http://www.cse.wustl.edu/~jain/cse574-16/> ©2016 Raj Jain

19-12

Pattern Division Multiple Access (PDMA)

- ❑ A variation of NOMA
- ❑ The users detect the signal with highest signal, subtract its waveform \Rightarrow Successive Interference Cancellation (SIC)
- ❑ Can increase spectral efficiency by a factor between 1 and 2.

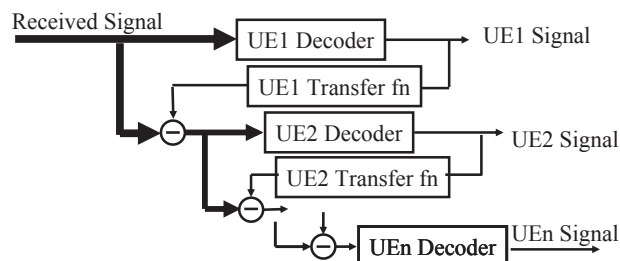

Ref: J. Zeng, et al, "Pattern Division Multiple Access (PDMA) for Cellular Future Radio Access," Intl Conf on Wireless Comm & Signal Proc (WCSP), Oct. 2015, 5 pp., <http://ieeexplore.ieee.org/xpl/login.jsp?tp=&arnumber=7341229>
Washington University in St. Louis <http://www.cse.wustl.edu/~jain/cse574-16/>

©2016 Raj Jain

19-13

Low Density Spreading (LDS)

- ❑ **Direct Sequence-CDMA:** Symbols are *spread* in time. Multiple users spread over at same time and frequency.
- ❑ **Multi-carrier CDMA:** Symbols are *spread* in frequency. Multiple users spread over same subcarriers at same time.
- ❑ **LDS:** Multi-carrier CDMA in which symbols are spread over large vectors most of whose elements are zero (sparse).
 - At each subcarriers, the number of interferers is small
 - Codes can even be randomly chosen
- ❑ Input and the output are multi-bit symbols and complex numbers.

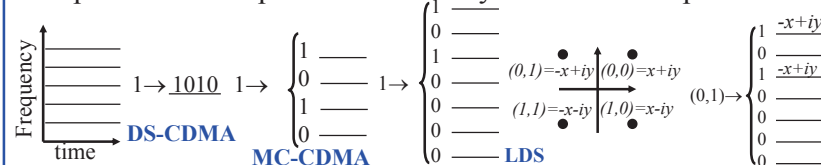

Ref: M. AL-imari, et al., "Low Density Spreading Multiple Access," J. Inform Tech Software Eng, Vol 2, Issue 4, 2012, <http://epubs.surrey.ac.uk/788182/1/Ready%20to%20Upload.pdf>

Washington University in St. Louis <http://www.cse.wustl.edu/~jain/cse574-16/>

©2016 Raj Jain

19-14

Sparse Code Multiple Access (SCMA)

- ❑ In stead of repeating the same symbol on different subcarriers (as in LDS), optimally coded symbols on different subcarriers.
- ❑ Symbols are mapped to higher-dimensional complex symbols and then mapped to subcarriers
 - K dimensions are spread over K subcarriers
- ❑ Codes are non-orthogonal \Rightarrow More code books and users can be supported than if limited to orthogonal
- ❑ Sparse \Rightarrow A lot of zeros in the code book \Rightarrow Easier to decode
 - All codes in one codebook have zeros in the same location
 - Each code book has K dimension of which N are zero.
- ❑ Total ${}^K C_N = \binom{K}{N}$ codebooks.
- ❑ Good for unscheduled random access without polling and grant scheduling \Rightarrow Good for IoT
- ❑ SCMA combines spreading and coding

Ref: P. Zhu, "5G Enabling Technologies," PIMRC, Sep 2014, 20 slides, http://www.ieee-pimrc.org/2014/2014-09-03%205G%20Enabling%20Technologies%20PIMRC%20Huawei_Final.pdf

Washington University in St. Louis <http://www.cse.wustl.edu/~jain/cse574-16/>

©2016 Raj Jain

19-15

SCMA Example

- ❑ 2-bit symbols to 4-dimensional symbols with 2 zeros: $K=4, N=2$
- ❑ Number of possible mappings ${}^4 C_2 = \binom{4}{2} = 6$ codebooks
- ❑ Six users can be supported over 4 subcarriers
- ❑ Each codebook has 2 zeros in the same rows for entire codebook.
- ❑ Combines spreading and coding \rightarrow QAM encoder \rightarrow Spread \rightarrow Spreading Encoder \rightarrow

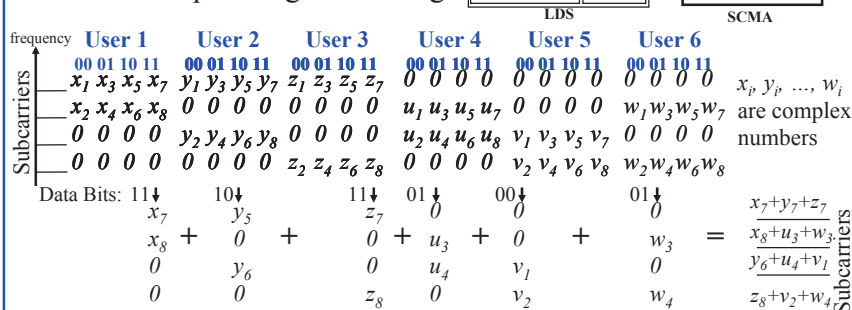

Ref: K. Au, et al, "Uplink Contention Based SCMA for 5G Radio Access," <http://arxiv.org/abs/1407.1407v1>

Washington University in St. Louis <http://www.cse.wustl.edu/~jain/cse574-16/>

©2016 Raj Jain

19-16

Interleave-Division Multiple Access (IDMA)

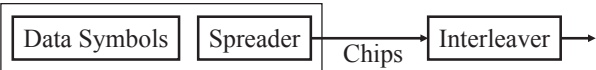
- ❑ **Interleaving:** Rearranging symbols according to a specified pattern \Rightarrow Reduces correlation between successive symbols
 $[0, 1, 2, 3, 4, 5, 6, 7, 8, 9, 0, 1] \times [2, 4, 3, 1] \rightarrow [1, 3, 2, 0, 5, 7, 6, 4, 9, 1, 0, 8]$
 - ❑ **DS-CDMA:** Symbols are interleaved then spread in to chips
- 
- ❑ **IDMA:** Symbols spread and then interleaved.
- 
- Different users have different interleaving pattern
 - Low-Rate Spreading \sim DS-CDMA without spreading \Rightarrow High spectral efficiency

Ref: J. C. Fricke, et al, "An Interleave-Division Multiple Access Based System Proposal for the 4G Uplink," IST Summit, 2005, 5 pp., http://www.agilon.de/Dr_Hendrik_Schoneich/Publications/Fricke_IST_Summit_2005.pdf
 Washington University in St. Louis <http://www.cse.wustl.edu/~jain/cse574-16/>

©2016 Raj Jain

19-17

New Efficient Spectrum Usage Techniques

1. 3D Beamforming and Massive MIMO
2. FDD-TDD Carrier Integration
3. Distributed Antenna Systems (DAS)
4. Simultaneous Transmission and Reception
5. Dynamic TDD
6. License Assisted Access (LAA)
7. Multimode Base Stations
8. Intelligent Multi-Mode RAT Selection
9. Higher order modulations in small cells

Washington University in St. Louis

<http://www.cse.wustl.edu/~jain/cse574-16/>

©2016 Raj Jain

19-18

3D Beamforming

- ❑ Aka 3D-MIMO or Full-dimension MIMO (**FD-MIMO**)
- ❑ Infinite Antennas = **Massive MIMO**

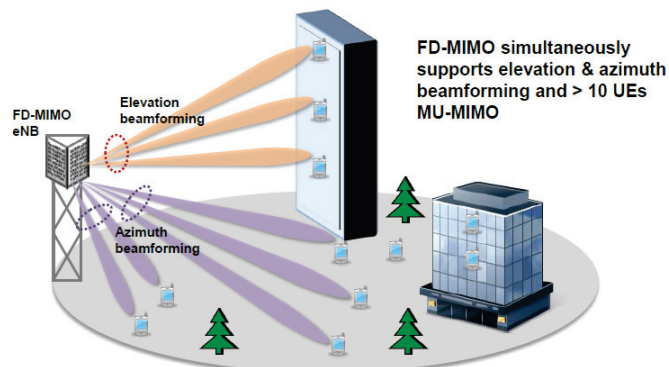

Ref: G. Xu, et al, "Full-Dimension MIMO: Status and Challenges in Design and Implementation," May 2014, http://www.ieee-ctw.org/2014/slides/session3/CTW_2014_Samsung_FD-MIMO.pdf
 Washington University in St. Louis <http://www.cse.wustl.edu/~jain/cse574-16/>

©2016 Raj Jain

19-19

FDD-TDD Carrier Integration

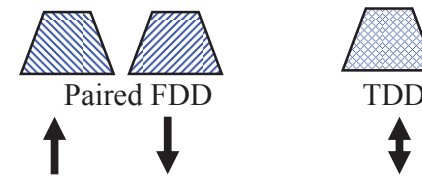

- ❑ Can aggregate Down FDD band with TDD in downlink
- ❑ Aggregate Up FDD band with TDD in uplink
- ❑ Use only FDD in Primary Cell and TDD in Small Cell or vice versa
- ❑ Generally FDD bands are lower frequency \Rightarrow Used for primary
- ❑ In future, 32 carriers could be aggregated

Washington University in St. Louis

<http://www.cse.wustl.edu/~jain/cse574-16/>

©2016 Raj Jain

19-20

Distributed Antenna Systems (DAS)

- Multiple antennas connected via cable
- Used for indoor coverage
- Need multiple cables for MIMO
- Some times the RF signal is converted to digital and transmitted over fiber optic cables and converted back to RF
⇒ Active DAS

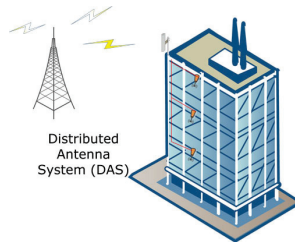

Simultaneous Transmission and Reception

- Also known as “**Full Duplex**” on the same frequency
⇒ Doubles the throughput, reduces end-to-end latency, allows transmitters to monitor the channel
- Difficult because transmitted signal too strong and interferes with reception ⇒ FDD (Large gap between transmit and receive frequencies) or TDD (Half-Duplex)
- Solution: **Self-Interference cancellation (SIC)** in analog and digital domain
- Similar techniques can be used to overcome BS-BS or UE-UE interference
- SIC can also be used in Multi-radio systems (WiFi and Bluetooth)

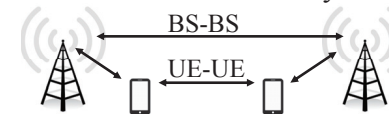

Dynamic TDD

- Time Division Duplexing (TDD) allows varying uplink to downlink ratio
- All cells in an area must synchronize their UL/DL subframes pattern, otherwise mobile's transmission get interference from neighboring BS
- LTE allows 7 variations of UL/DL subframe patterns.
S=Switchover time from D to U

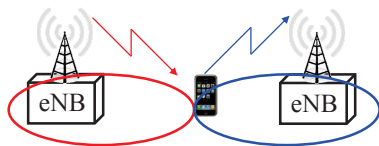

TDD Conf	TTI index									
	0	1	2	3	4	5	6	7	8	9
0	D	S	U	U	U	D	S	U	U	U
1	D	S	U	U	D	D	S	U	U	D
2	D	S	U	D	D	D	S	U	D	D
3	D	S	U	U	U	D	D	D	D	D
4	D	S	U	U	D	D	D	D	D	D
5	D	S	U	D	D	D	D	D	D	D
6	D	S	U	U	U	D	S	U	U	D

Dynamic TDD (Cont)

- Too many U's or D's in a row delay acks/nacks and affect the usefulness of HARQ.
- Release 12 added flexible “F” subframes that can be declared as S, D, or U ⇒ Can change every 10 ms.
- Enhanced Interference Mitigation and Traffic Adaptation (eIMTA)**: Cells can change UL/DL pattern as needed. Mobiles asked to transmit at higher power if needed.
- This will be further enhanced for 5G

TTI index										
	0	1	2	3	4	5	6	7	8	9
	D	S	U	F	F	D	S/D	F	F	F

License Assisted Access (LAA)

- ❑ A.k.a. unlicensed LTE (LTE-U). Release 13.
- ❑ 5 GHz band for public hot-spots and in-building
- ❑ Different rules and bands in different countries, e.g.,
 - Avoid if a radar is operating
 - Can't block 20 MHz if using only 180 kHz
 - Transmit only if free. Recheck after maximum occupancy time ⇒ Can not transmit continuously as in standard LTE
- ❑ End-to-End LTE ⇒ Better integration than with WiFi
- ❑ May use as a downlink-only carrier aggregation

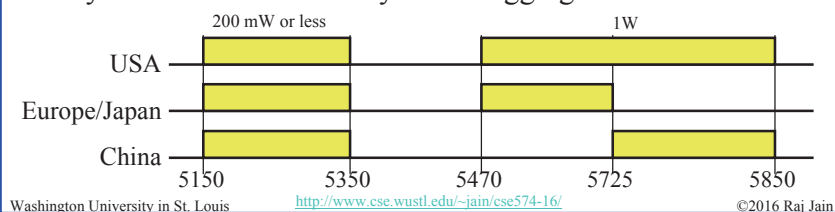

Washington University in St. Louis <http://www.cse.wustl.edu/~jain/cse574-16/> ©2016 Raj Jain

19-25

Multimode Base Stations

- ❑ 2G/3G/4G/WiFi/WiMAX, multi-band, multi-frequency, multiple modulation formats, multiple air interfaces
- ❑ Need “Software Define Radios (SDRs)”
 - Analog signal is sampled at a very high rate and processed using digital signal processing (DSP)
 - DAC, ADC, and PA are the most expensive parts

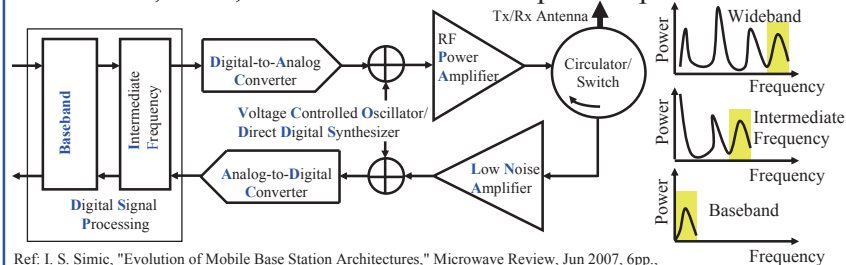

Ref: I. S. Simic, "Evolution of Mobile Base Station Architectures," Microwave Review, Jun 2007, 6pp., http://www.mtt-serbia.org.rs/microwave_review/pdf/Vol13No1-07-I-Simic.pdf
 Washington University in St. Louis <http://www.cse.wustl.edu/~jain/cse574-16/> ©2016 Raj Jain

19-26

Intelligent Multi-Mode RAT Selection

- ❑ Selecting between LTE, WiFi, 3G, ...
- ❑ Can not just select
 - Highest speed
 - Highest signal power
 - Cheapest
- ❑ Correct choice also depends upon the type of traffic: voice vs. data ⇒ Network assisted selection

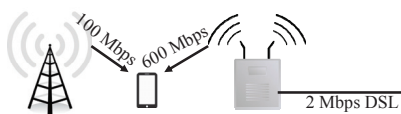

Ref: 4G Americas, "Integration of Cellular and WiFi Networks," Sep 2013, 65 pp., http://www.4gamericas.org/files/3114/0622/2546/Integration_of_Cellular_and_WiFi_Networks_White_Paper-9.25.13.pdf
 Washington University in St. Louis <http://www.cse.wustl.edu/~jain/cse574-16/> ©2016 Raj Jain

19-27

Hyper-Dense Small Cells

- ❑ Used in extremely busy areas. Sports arena, Malls, Metro trains ⇒ Heterogeneous and Small Cell Network (HetSNets)
- ❑ Self-Organizing: Neighbor discovery, parameter setting,
- ❑ Backhaul Flexibility: DSL, HomePlug, Wireless, ...
- ❑ Mobility-Management:
 - Frequent Handovers Mitigation: Ping-pong. Network assisted as in intelligent multi-mode RAT selection
 - Forward Handover: Small cell can prefetch user context from the Serving cell
- ❑ Load balancing between small cells and with macro cell
- ❑ Multi-RAT Management: 2G/3G/4G/WiFi
- ❑ Privately Owned: Security and Incentive issues

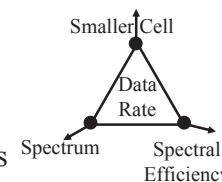

Ref: I. Hwang, B. Song, and S. S. Soliman, "A Holistic View on Hyper-Dense Heterogeneous and Small Cell Networks," IEEE Communications Magazine, Jun 2013, pp. 20-27, <http://blog.sciencenet.cn/home.php?mod=attachment&id=62246>
 Washington University in St. Louis <http://www.cse.wustl.edu/~jain/cse574-16/> ©2016 Raj Jain

19-28

New Energy Saving Mechanisms

1. Discontinuous Transmission (DTX)
2. Antenna Muting
3. Cell on/off switching
4. Power Save Mode for IoT

Discontinuous Transmission (DTX)

- ❑ Do not transmit during silence \Rightarrow Resources can be reused by others
- ❑ Was difficult to do in static allocation like GSM
- ❑ Already part of LTE

Antenna Muting

- ❑ Base stations have multiple antenna for MIMO
- ❑ Antenna Muting: Turn off some antenna at low load
- ❑ Advantage: Energy savings
- ❑ Problem: Number of antenna is assumed fixed and each antenna has its own pilot signals
 - Space-Frequency Block Code (SFBC) is used to transmit different frequency components from different antenna
 - \Rightarrow Throughput reduces
- ❑ Studies have shown significant energy savings with acceptable loss in throughput at low load.
- ❑ In 5G number of Antenna will become dynamic



Cell On/Off Switching

- ❑ Under low load a cell or small cell can be turned off
- ❑ Off cells broadcast "Discovery reference signals (DRS)" periodically so that they can be turned on if necessary
- ❑ Takes a few hundred ms
- ❑ Used for energy consumption during nights

CapEx/OpEx Reduction Techniques

1. Software Defined Networking (SDN)
2. Network Function Virtualization (NFV)
3. Mobile Edge Computing (MEC)
4. Cloud Radio Access Network (C-RAN)

Software Defined Networking (SDN)

1. **Abstract the Hardware:** No dependence on physical infrastructure. Software API.
2. **Programmable:** Shift away from static manual operation to fully configurable and dynamic
3. **Centralized Control of Policies:** Policy delegation and management

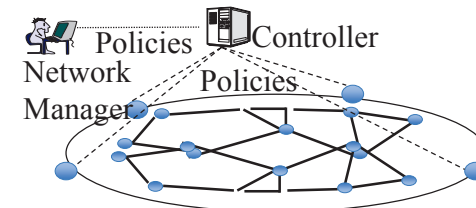

Network Function Virtualization

- ❑ Standard hardware is fast and cheap \Rightarrow No specialized hardware
- ❑ Implement all functions in software
- ❑ Virtualize all functions \Rightarrow Cloud \Rightarrow Create capacity on demand

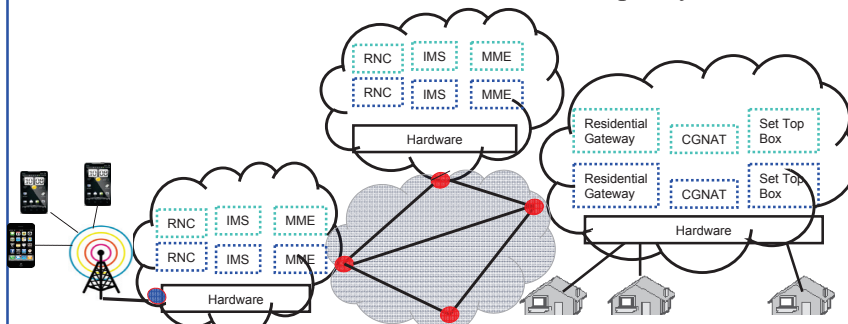

Mobile Edge Computing (MEC)

- ❑ To service mobile users/IoT, the computation needs to come to edge \Rightarrow Mobile Edge Computing

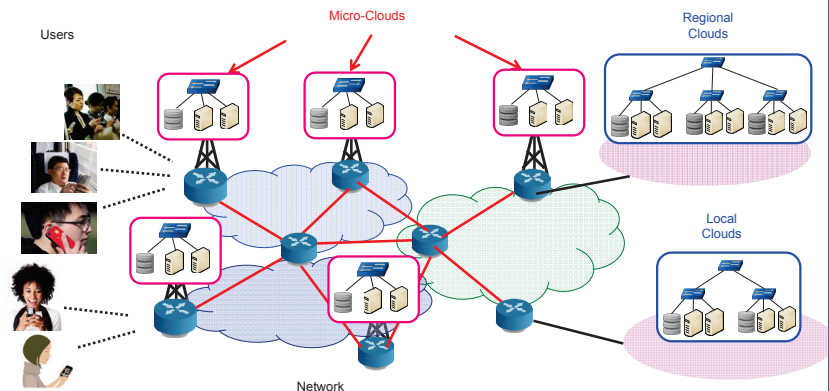

Cloud Radio Access Network (C-RAN)

- Centralize baseband processing in a cloud
- Need to carry high-bit rate signal (after A-to-D conversion) from tower to cloud site ~ 10 Gbps
- Optical fiber, 10 Gbps Ethernet, Microwave can be used depending upon the distance ~ 1-20 km of **fronthaul**
- Particularly good for dense small cells. Multi-provider support.

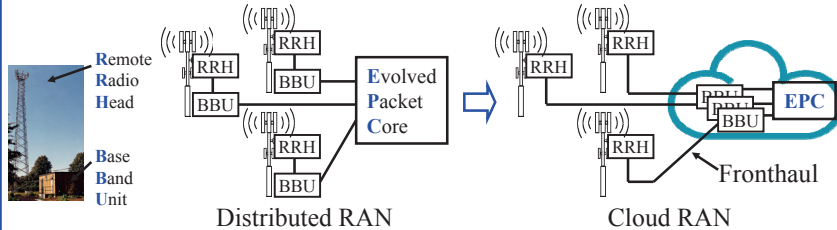

Ref: C. I, et al, "Recent Progress on C-RAN Centralization and Cloudification," IEEE Access, Vol. 2, 2014, pp. 1030-1039, <http://ieeexplore.ieee.org/iel7/6287639/6514899/06882182.pdf?arnumber=6882182>
Washington University in St. Louis <http://www.cse.wustl.edu/~jain/cse574-16/>

19-37

New Spectrum

- ITU estimates 900-1420 MHz required for 4G/5G by 2020 and 440-540 MHz required for 2G/3G and their enhancements

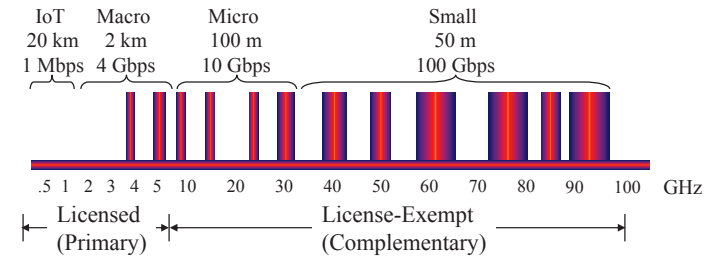

Ref: P. Zhu, "5G Enabling Technologies," PIMRC, Sep 2014, 20 slides, http://www.ieee-pimrc.org/2014/2014-09-03%205G%20Enabling%20Technologies%20PIMRC%20Huawei_Final.pdf
Ref: ITU-R M.2290-0, "Future Spectrum Requirements estimate for Terrestrial IMT," Dec 2013, http://www.itu.int/dms_pub/itu-r/rep/R-REP-M.2290-2014-PDF-E.pdf
Huawei, "White Paper on Spectrum," February 2013, http://www.huawei.com/us4/itp/index-cdf_en_group_white_book.htm
Washington University in St. Louis <http://www.cse.wustl.edu/~jain/cse574-16/>

19-38

Above 6 GHz

- Free-space loss increases in proportion to square of frequency and square of distance. 88 dB loss with 30 GHz at 20 m \Rightarrow 10-100 m cell radius
- Outdoor-to-Indoor: Glass windows add 20-40 dB
- Mobility: Doppler shift is proportional to frequency and velocity. Multipath results in varying Doppler shifts \Rightarrow Lower mobility
- Wide Channels: Duplex filters cover only 3-4% of center frequency \Rightarrow Need carrier aggregation.
- Antenna: 8x8 array at 60 GHz is only 2cm x 2cm. A/D and D/A converters per antenna element may be expensive
- 2 Gbps to 1 km is feasible using mm waves

Ref: ITU-R M2376-0, "Technical Feasibility of IMT in bands above 6 GHz," July 2015, http://www.itu.int/dms_pub/itu-r/rep/R-REP-M.2376-2015-PDF-E.pdf
Washington University in St. Louis <http://www.cse.wustl.edu/~jain/cse574-16/>

©2016 Raj Jain

19-39

Application Specific Improvements

- Internet of Things
- Video

Washington University in St. Louis

<http://www.cse.wustl.edu/~jain/cse574-16/>

©2016 Raj Jain

19-40

LTE Applications

- ❑ Machine Type Communication (MTC): M2M or IoT
 - Versus current Human Type Communication (HTC)
 - GSM and HSPA modems for ~\$5 are potential choices
 - Extended Coverage GSM (EC-GSM): Half-duplex FDD, Power Saving Mode (Same as LTE), 20 dB enhancements in link budget (total 164 dB) in R13 ⇒ 7x range for low rate
- ❑ Device-to-Device (D2D): Proximity services (Nearby search), enable direct device-to-device communication if nearby.
 - Low Latency D2D: Vehicular networking
- ❑ Group Communication: Public Safety (Fire, Police), push-to-talk
- ❑ Enhanced Multimedia Broadcast Multicast System (eMBMS): Broadcast Services (TV)

Machine Type Communication

- ❑ **LTE Low-cast (Category 0) UE:** In Release 12.
 - Single Antenna
 - Reduced peak rate up to 1 Mbps
 - Half-Duplex ⇒ No duplex filter
 - Power saving mode (PSM)
- ❑ **MTC LTE (LTE-M) (Category -1) UE:** In Release 13.
 - 1 Mbps using 1.4 MHz = 6 Physical Resource Blocks (PRB)
 - All power on fewer subcarriers ⇒ **Power Spectral Density (PSD) Boosting** ⇒ 15 dB reduction in link budget by PSD and repetition ⇒ Allows UEs in basements and indoors
 - Reduced Tx power to 20 dBm ⇒ integrated amplifier
- ❑ **Narrow Band LTE (NB-LTE)** introduced Category -2 UE:
 - 128 kbps using 200 kHz band = Single PRB
 - 23 dBm power (required to maintain the link budget)
- ❑ Both LTE-M and NB-LTE UEs use single RF chain

Signaling Enhancements for MTC

- ❑ **Enhanced Physical Downlink Control Channel (EPDCCH)**
- ❑ LTE Cat 0 UE receive signaling in the entire 20 MHz band
- ❑ LTE-M UEs receive signaling in their 1.4 MHz band
- ❑ For NB-LTE UEs, signaling is part of the assigned PRB

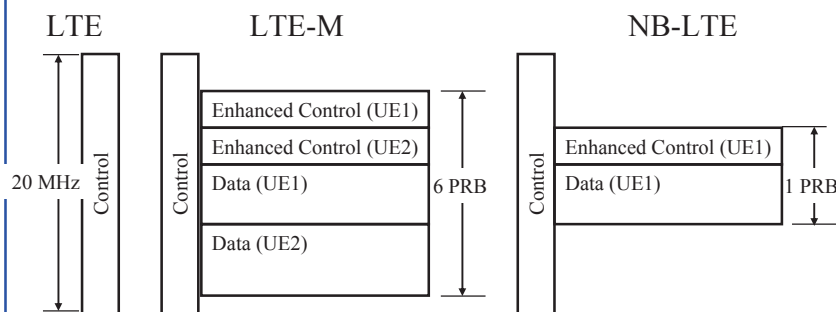

Power Saving Mode (PSM)

- ❑ Discontinuous Reception (DRX). Introduced in Release 12
- ❑ Allows UE to stay registered while sleeping
- ❑ UE's need to monitor resource allocation channel even if it has nothing to send or receive
- ❑ Connected mode DRX (cDRX): UE can sleep and periodically wake up to check the control channel
 - Short sleep cycle: 5 to 400 ms
 - Long sleep cycle: 20 ms to 2.5s (if no activity for 4 short cycles)



Dynamic Adaptive Streaming over HTTP (DASH)

- Video is the major component of mobile traffic
⇒ DASH provides an efficient method for video streaming
- Standard developed jointly by 3GPP, ISO, Open IPTV Forum
- Standard Web Servers: No changes required to servers, Content Distribution Networks (CDN), or HTTP protocol. HTTP passes easily through firewalls
- Mobile client controls what is downloaded using a “media presentation description (MPD)” file defined by DASH
- MPD contains URLs for segments
- Client requests segments as needed. Allows fast forward, rewind, etc.

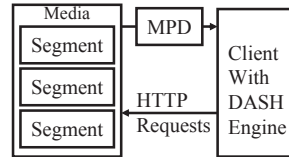

Ref: T. Stockhammer, "Dynamic Adaptive Streaming over HTTP – Standards and Design Principles," MMSys'11, Feb 2011, San Jose, CA, <https://svn-itec.uni-klu.ac.at/trac2/dash/export/58/trunk/documentation/02%20mmi21da-stockhammer.pdf>
Washington University in St. Louis <http://www.cse.wustl.edu/~jain/cse574-16/> ©2016 Raj Jain

19-45



Summary

1. Current IMT Vision document defines 5G in terms of 8 parameters: a peak rate up to 20 Gbps per user, User experienced rate of 100 Mbps, spectral efficiency 3 times of 4G, Mobility support to 500 km/h, a latency of 1 ms, a density of a million connections per m², energy efficiency 100x of 4G, and traffic capacity of 10 Mbps/m².
2. New radio multiplexing techniques include f-OFDM, FBMC, NOMA, PDMA, LDS, SCMA, and IDMA
3. New spectrum utilization techniques include 3D Beamforming, Massive MIMO, FDD-TDD Carrier Integration, DAS, Simultaneous Transmission and Reception, Dynamic TDD, LAA, Multimode Base Stations, Intelligent Multi-Mode RAT Selection, and Higher order modulations in small cells
4. New energy savings mechanisms include Discontinuous Transmission (DTX), Antenna Muting, Cell on/off switching, and Power Save Mode for IoT
5. Capex/OpEx reduction techniques include SDN, NFV, MEC, and C-RAN.
6. Application specific improvements include LTE-M, NB-LTE for IoT and DASH for video.
7. New license-exempt spectrum in 6GHz-100 GHz will complement the licensed spectrum.

Washington University in St. Louis <http://www.cse.wustl.edu/~jain/cse574-16/> ©2016 Raj Jain

19-46

Reading List

- ITU-R Recommendation M.2083-0, "IMT Vision - Framework and overall objectives of the future development of IMT for 2020 and beyond," Sep. 2015, 21 pp., https://www.itu.int/dms_pubrec/itu-r/rec/m/R-REC-M.2083-0-201509-1!!PDF-E.pdf
- ITU-R M.2290-0, "Future Spectrum Requirements estimate for Terrestrial IMT," Dec 2013, http://www.itu.int/dms_pub/itu-r/opb/rep/R-REP-M.2290-2014-PDF-E.pdf
- ITU-R M2376-0, "Technical Feasibility of IMT in bands above 6 GHz," July 2015, http://www.itu.int/dms_pub/itu-r/opb/rep/R-REP-M.2376-2015-PDF-E.pdf
- J. Zeng, et al, "Pattern Division Multiple Access (PDMA) for Cellular Future Radio Access," Intl Conf on Wireless Comm & Signal Proc (WCSP), Oct. 2015, 5 pp., <http://ieeexplore.ieee.org/xpl/login.jsp?tp=&arnumber=7341229>
- K. Au, et al, "Uplink Contention Based SCMA for 5G Radio Access," <http://arxiv.org/vc/arxiv/papers/1407/1407.5495v1.pdf>
- M. AL-imari, et al., "Low Density Spreading Multiple Access," J. Inform Tech Software Eng, Vol 2, Issue 4, 2012, <http://epubs.surrey.ac.uk/788182/1/Ready%20to%20Upload.pdf>

Washington University in St. Louis <http://www.cse.wustl.edu/~jain/cse574-16/> ©2016 Raj Jain

19-47

Reading List (Cont)

- M. Bellanger, "FBMC physical layer - principle," June 2011, 13 slides, [http://www.cept.org/Documents/se-43/500/SE43\(11\)Info06_FBMC-physical-layer-principle](http://www.cept.org/Documents/se-43/500/SE43(11)Info06_FBMC-physical-layer-principle)
- A. Altamimi, "Interleave Division Multiple Access (IDMA)," <http://www.ece.uvic.ca/~cai/IDMA.pdf>
- I. Hwang, B. Song, and S. S. Soliman, "A Holistic View on Hyper-Dense Heterogeneous and Small Cell Networks," IEEE Communications Magazine, Jun 2013, pp. 20-27, <http://blog.sciencenet.cn/home.php?mod=attachment&id=62246>
- D. Batista, et al, "Perspectives on software-defined networks: interviews with five leading scientists from the networking community" Journal of Internet Services and Applications 2015, 6:22, <http://www.cse.wustl.edu/~jain/papers/jisa15.htm>
- C. I, et al, "Recent Progress on C-RAN Centralization and Cloudification," IEEE Access, Vol. 2, 2014, pp. 1030-1039, <http://ieeexplore.ieee.org/iel7/6287639/6514899/06882182.pdf?arnumber=6882182>

Washington University in St. Louis <http://www.cse.wustl.edu/~jain/cse574-16/> ©2016 Raj Jain

19-48

Wikipedia Links

- ❑ <https://en.wikipedia.org/wiki/5G>
- ❑ https://en.wikipedia.org/wiki/Machine_to_machine
- ❑ https://en.wikipedia.org/wiki/LTE_in_licensed_spectrum
- ❑ https://en.wikipedia.org/wiki/LTE_in_licensed_spectrum#License_Assisted_Access_28LAA.29
- ❑ https://en.wikipedia.org/wiki/Discontinuous_transmission
- ❑ https://en.wikipedia.org/wiki/Software-defined_networking
- ❑ https://en.wikipedia.org/wiki/Network_function_virtualization
- ❑ https://en.wikipedia.org/wiki/Mobile_edge_computing
- ❑ <https://en.wikipedia.org/wiki/C-RAN>
- ❑ https://en.wikipedia.org/wiki/Small_cell
- ❑ https://en.wikipedia.org/wiki/Distributed_antenna_system
- ❑ https://en.wikipedia.org/wiki/Dynamic_Adaptive_Streaming_over_HTTP
- ❑ <https://en.wikipedia.org/wiki/3GPP>
- ❑ <https://en.wikipedia.org/wiki/Beamforming>
- ❑ https://en.wikipedia.org/wiki/Discontinuous_reception

Wikipedia Links (Cont)

- ❑ https://en.wikipedia.org/wiki/Distributed_antenna_system
- ❑ https://en.wikipedia.org/wiki/Multicast-broadcast_single-frequency_network
- ❑ https://en.wikipedia.org/wiki/Multimedia_Broadcast_Multicast_Service
- ❑ https://en.wikipedia.org/wiki/NarrowBand_IOT

References

- ❑ 4G Americas, "Integration of Cellular and WiFi Networks," Sep 2013, 65 pp., http://www.4gamericas.org/files/3114/0622/2546/Integration_of_Cellular_and_WiFi_Networks_White_Paper-9.25.13.pdf
- ❑ G. Ding, et al, "Application of Non-orthogonal Multiple Access in LTE and 5G Networks," <https://pdfs.semanticscholar.org/a404/21a9762db528bfe848166765fee43e740c94.pdf>
- ❑ G. Xu, et al, "Full-Dimension MIMO: Status and Challenges in Design and Implementation," May 2014, http://www.ieee-ctw.org/2014/slides/session3/CTW_2014_Samsung_FD-MIMO.pdf
- ❑ Huawei, "5G: New Air Interface and Radio Access Virtualization," April 2015, 6 pp., http://www.huawei.com/minisite/has2015/img/5g_radio_whitepaper.pdf
- ❑ Huawei, "White Paper on Spectrum," February 2013, http://www.huawei.com/us/others/index-cdf_en_group_white_book.htm

References (Cont)

- ❑ I. S. Simic, "Evolution of Mobile Base Station Architectures," Microwave Review, Jun 2007, 6pp., http://www.mtt-serbia.org.rs/microwave_review/pdf/Vol13No1-07-ISimic.pdf
- ❑ IMT-2020 (5G) Promotion Group, "5G Concept," Feb 2015, 18 pp., <http://www.imt-2020.cn/en/documents/download/25>
- ❑ Huawei, "White Paper on Spectrum," February 2013, http://www.huawei.com/us/others/index-cdf_en_group_white_book.htm
- ❑ ITU-R M2376-0, "Technical Feasibility of IMT in bands above 6 GHz," July 2015, http://www.itu.int/dms_pub/itu-r/opb/rep/R-REP-M.2376-2015-PDF-E.pdf
- ❑ ITU-R, "Workplan, timeline, process and deliverables for the future development of IMT," 4pp., <http://www.itu.int/en/ITU-R/study-groups/rsg5/rwp5d/imt-2020/Documents/Antipated-Time-Schedule.pdf>
- ❑ J. C. Fricke, et al, "An Interleave-Division Multiple Access Based System Proposal for the 4G Uplink," IST Summit, 2005, 5 pp., http://www.agilon.de/Dr_Hendrik_Schoneich/Publications/Fricke_IST_Su mmit_2005.pdf

References (Cont)

- L. Gupta, R. Jain, H. Chan, "Mobile Edge Computing - an important ingredient of 5G Networks," IEEE Softwarization Newsletter, March 2016, <http://sdn.ieee.org/newsletter/march-2016/mobile-edge-computing-an-important-ingredient-of-5g-networks>
- P. Skillermark and P. Frenger, "Enhancing Energy Efficiency in LTE with Antenna Muting," 75th Vehicular Technology Conf. (VTC Spring), Yokohama, 2012, pp. 1-5, <https://pdfs.semanticscholar.org/29ec/17e00ccae04ae34b74f9e6e62c1e2c42d789.pdf>
- P. Zhu, "5G Enabling Technologies," PIMRC, Sep 2014, 20 slides, http://www.ieee-pimrc.org/2014/2014-09-03%205G%20Enabling%20Technologies%20PIMRC%20Huawei_Final.pdf
- Raj Jain, "SDN and NFV: Facts, Extensions, and Carrier Opportunities," AT&T Labs SDN Forum Seminar, April 10, 2014, http://www.cse.wustl.edu/~jain/papers/adn_att.htm

References (Cont)

- T. Stockhammer, "Dynamic Adaptive Streaming over HTTP - Standards and Design Principles," MMSys'11, Feb 2011, San Jose, CA, <https://svn-itec.uni-klu.ac.at/trac2/dash/export/58/trunk/documentation/02%20mmt21da-stockhammer.pdf>
- V. Pauli, Y. Li, E. Seidel, "Dynamic TDD for LTE-A and 5G," Nomor Research GmbH, Sep 2015, 8 pp., http://nashville.dyndns.org:823/YourFreeLibrary/ lte/LTE%20advanced/W hitePaperNomor_LTE-A_5G-eIMTA_2015-09.pdf
- W. Afifi and M. Krunz, "Adaptive Transmission-Reception-Sensing Strategy for Cognitive Radios with Full-duplex Capabilities," April 2010, 12 pp., <http://www2.engr.arizona.edu/~wessamafifi/DySPAN14.pdf>
- ITU-R M.2370-0, "IMT traffic estimates for the years 2020 to 2030," Jul 2015, 51 pp., http://www.itu.int/dms_pub/itu-r/opb/rep/R-REP-M.2370-2015-PDF-E.pdf
- ITU-R M.2012-2, "Detailed specifications of the terrestrial radio interfaces of International Mobile Telecommunications-Advanced (IMT-Advanced)," Sep 2015, 168 pp., https://www.itu.int/dms_pubrec/itu-r/rec/m/R-REC-M.2012-2-201509-!!!PDF-E.pdf

References (Cont)

- Ericsson, "LTE Release 13," April 2015, 10 pp., <http://www.ericsson.com/res/docs/whitepapers/150417-wp-lte-release-13.pdf>
- 4G_Americas, "LTE_Carrier_Aggregation: Technology Development and Deployment Worldwide," October 2014, 53 pp., http://www.4gamericas.org/files/8414/1471/2230/4G_Americas_Carrier_Aggregation_FINALv1_0_3.pdf
- 4G_Americas, "Cellular_Technologies_Enabling_the_Internet_of_Things," Nov. 2015, 65 pp., http://www.4gamericas.org/files/6014/4683/4670/4G_Americas_Cellular_Technologies_Enabling_the_IoT_White_Paper_-_November_2015.pdf
- Huawei, "Active Antenna System," November 2012, 16 pp., <http://www1.huawei.com/en/static/AAS-129092-1-197969.pdf>
- T. Lomar, et al., "Delivering Content with LTE Broadcast," Ericsson Review, Feb 2013, 8 pp., http://www.ericsson.com/res/thecompany/docs/publications/ericsson_review/2013/e-r-lte-broadcast.pdf

References (Cont)

- Viavi Solutions Inc., "LTE Evolved Multimedia Broadcast Multicast Services (eMBMS)," 2015, 16 pp., <http://www.viavisolutions.com/sites/default/files/technical-library-items/lteembms-wp-nsd-nse-ae.pdf>
- Nokia, "LTE Networks for Public Safety Services," 2014, 24 pp., http://networks.nokia.com/sites/default/files/document/nokia_lte_for_public_safety_white_paper.pdf
- Nokia, "LTE for Unlicensed Spectrum," 2014, 12 pp., http://networks.nokia.com/sites/default/files/document/nokia_lte_unlicensed_white_paper.pdf
- Nokia, "LTE-M – Optimizing LTE for the Internet of Things," 2015, http://networks.nokia.com/sites/default/files/document/nokia_lte-m_-_optimizing_lte_for_the_internet_of_things_white_paper.pdf
- Ericsson, "Cellular Networks for Massive IoT," Jan 2016, http://www.ericsson.com/res/docs/whitepapers/wp_iot.pdf
- DAS Forum, "Distributed Antenna Systems (DAS)," 33 slides, <http://www.newjerseywireless.org/3.0/docs/njwadasnov16final.pdf>

References (Cont)

- Ericsson, "LTE License Assisted Access," 18 slides, http://www.ericsson.com/res/thecompany/docs/press/media_kits/ericsson-license-assisted-access-laa-january-2015.pdf
- B. Bertenyi, "LTE Standards for Public Safety – 3GPP View," 25 slides, May 2013, http://www.3gpp.org/IMG/pdf/2013_05_3gpp_ccw.pdf
- Qualcomm Research, "LTE eMBMS Technology Overview," 18 slides, Nov 2012, https://s3.amazonaws.com/sdieee/222-eMBMS_tech_overview_IEEE_112712.pdf
- M. Blanco, "Carrier Aggregation: Fundamentals and Deployments," 34 slides, 2014, http://www.keysight.com/upload/cmc_upload/All/23Jan14WebcastSlides.pdf

References (Cont)

- T. L. Marzetta, "Noncooperative Cellular Wireless with Unlimited Numbers of Base Station Antennas," in *IEEE Transactions on Wireless Communications*, vol. 9, no. 11, pp. 3590-3600, November 2010, <http://ieeexplore.ieee.org/xpl/articleDetails.jsp?arnumber=5595728> (Original paper on Massive MIMO)
- R. Hoshyar, et al., "Novel Low-Density Signature for Synchronous CDMA Systems Over AWGN Channel," *IEEE Trans on Signal Processing*, Vol. 56, No. 4, April 2008, pp. 1616-1626, <https://pdfs.semanticscholar.org/5e4b/405202c92fd77a12f463ca1247a8b59fd935.pdf> (Original paper on LDS)
- H. Nikopour and H. Baligh, "Sparse Code Multiple Access," 24th International Symposium on Personal, Indoor and Mobile Radio Communications: Fundamentals and PHY Track, 2013, <http://ieeexplore.ieee.org/xpl/login.jsp?tp=&arnumber=6666156> (Original Paper on SCMA)
- L. Ping, et al, "Interleave-Division Multiple-Access," *IEEE Transactions on Wireless Communications*, Vol. 5, No. 4, April 2006, <http://www.ee.cityu.edu.hk/~liping/Research/Journal/IDMA2.pdf> (Original paper on IDMA)

References (Cont)

- D. W. Bliss, P. A. Parker, A. R. Margetts, "Simultaneous Transmission and Reception for Improved Wireless Network Performance," 2007 IEEE/SP 14th Workshop on Statistical Signal Processing, Madison, WI, 26-29 Aug. 2007, pp. 478 - 482, <http://ieeexplore.ieee.org/xpl/articleDetails.jsp?arnumber=4301304> (Original paper on Simultaneous Transmit and Receive)
- E. Arikian, "Channel Polarization: A Method for Constructing Capacity-Achieving Codes for Symmetric Binary-Input Memoryless Channels," in *IEEE Transactions on Information Theory*, vol. 55, no. 7, pp. 3051-3073, July 2009, <http://ieeexplore.ieee.org/xpl/articleDetails.jsp?arnumber=5075875> (Original paper on Polar Codes)

Acronyms

- | | |
|---------|--|
| □ 3GPP | 3rd Generation Partnership Project |
| □ ADC | Analog-to-Digital Converter |
| □ API | Application Programming Interface |
| □ AWGN | Additive White Gaussian Noise |
| □ BBU | Broadband Unit |
| □ BS | Base Station |
| □ CapEx | Capital Expenditure |
| □ CDMA | Code Division Multiple Access |
| □ CDN | Content Distribution Networks |
| □ cDRX | Connected mode discontinuous reception |
| □ CGNAT | Carrier Grade Network Address Translator |
| □ DAC | Digital-to-Analog Converter |
| □ DAS | Distributed Antenna Systems |
| □ DASH | Dynamic Adaptive Streaming over HTTP |
| □ dB | DeciBel |
| □ dBm | DeciBel Milliwatt |

Acronyms (Cont)

- ❑ DL Downlink
- ❑ DRS Discovery reference signals
- ❑ DRX Discontinuous Reception
- ❑ DS-CDMA Direct Sequence Code Division Multiple Access
- ❑ DSL Digital Subscriber Line
- ❑ DSP Digital signal processing
- ❑ DTX Discontinuous Transmission
- ❑ eIMTA Enhanced Interference Mitigation and Traffic Adaptation
- ❑ eMBMS Enhanced Multimedia Broadcast Multicast System
- ❑ eNB Evolved Node-B
- ❑ EPC Evolved Packet Core
- ❑ EPDCCH Enhanced Physical Downlink Control Channel
- ❑ FBMC Filtered Bank Multicarrier
- ❑ FD-MIMO Full Dimension MIMO
- ❑ FDD Frequency Division Duplexing
- ❑ GHz Giga Hertz

Acronyms (Cont)

- ❑ GSM Global System for Mobile Telephony
- ❑ HARQ Hybrid Automatic Repeat Request
- ❑ HetSNets Heterogeneous Small Cell Network
- ❑ HSPA High Speed Packet Access
- ❑ HTC Human Type Communication
- ❑ HTTP Hyper-Text Transfer Protocol
- ❑ IDMA Interleave Division Multiple Access
- ❑ IEEE Institution of Electrical and Electronic Engineers
- ❑ IMS IP Multimedia System
- ❑ IMT-2020 5G
- ❑ IMT International Mobile Telecommunications
- ❑ IoT Internet of Things
- ❑ IPTV Internet Protocol Television
- ❑ ISO International Standards Organization
- ❑ ITU-R International Telecommunications Union- Radio
- ❑ ITU International Telecommunications Union

Acronyms (Cont)

- ❑ kHz Kilo Hertz
- ❑ LAA License Assisted Access
- ❑ LDS Low Density Spreading
- ❑ LTE-A Long-Term Evolution Advanced
- ❑ LTE-M Long-Term Evolution for Machine Type Communication
- ❑ LTE-U Long-Term Evolution Unlicensed
- ❑ LTE Long-Term Evolution
- ❑ MC-CDMA Multi-carrier Code Division Multiple Access
- ❑ MEC Mobile Edge Computing
- ❑ MHz Mega Hertz
- ❑ MIMO Multiple Input Multiple Output
- ❑ MME Mobility Management Entity
- ❑ MPD Media presentation description
- ❑ MTC Machine Type Communication
- ❑ mW Milli Watt
- ❑ NB-LTE Narrowband Long Term Evolution

Acronyms (Cont)

- ❑ NFV Network Function Virtualization
- ❑ NOMA Non-Orthogonal Multiple Access
- ❑ OFDM Orthogonal Frequency Division Multiplexing
- ❑ OFDMA Orthogonal Frequency Division Multiple Access
- ❑ OpEx Operational Expenditure
- ❑ PA Power Amplifier
- ❑ PDMA Pattern Division Multiple Access
- ❑ PHY Physical Layer
- ❑ PRB Physical Resource Blocks
- ❑ PSD Power Spectral Density
- ❑ PSM Power Saving Mode
- ❑ QAM Quadrature Amplitude Monitor
- ❑ QoE Quality of Experience
- ❑ QoS Quality of Service
- ❑ RAN Radio Access Network
- ❑ RAT Radio Access Technology

Acronyms (Cont)

- ❑ REC Recommendation
- ❑ REP Report
- ❑ RF Radio Frequency
- ❑ RNC Radio Network Controller
- ❑ RRH Remote Radio Head
- ❑ SCMA Sparse code multiple access
- ❑ SDN Software Defined Networking
- ❑ SDR Software Defined Radios
- ❑ SFBC Space-Frequency Block Code
- ❑ SIC Successive Interference Cancellation
- ❑ TDD Time Division Duplexing
- ❑ TV Television
- ❑ UE User Element
- ❑ UL Uplink
- ❑ URL Uniform Resource Locator
- ❑ USA United States of America

Acronyms (Cont)

- ❑ VTC Vehicular Technology Conference
- ❑ WCSP Wireless Communications and Signal Processing
- ❑ WiFi Wireless Fidelity
- ❑ WiMAX Worldwide Interoperability for Microwave Access

Scan This to Get These Slides



Related Modules



Introduction to Cellular Networks: 1G/2G/3G,
http://www.cse.wustl.edu/~jain/cse574-16/j_15cel.htm



Introduction to LTE,
http://www.cse.wustl.edu/~jain/cse574-16/j_16lte.htm



Introduction to 4G: LTE-Advanced,
http://www.cse.wustl.edu/~jain/cse574-16/j_17lta.htm



Low Power WAN Protocols for IoT,
http://www.cse.wustl.edu/~jain/cse574-16/j_14ahl.htm



Audio/Video Recordings and Podcasts of
Professor Raj Jain's Lectures,
<https://www.youtube.com/channel/UCN4-5wzNP9-ruOzQMs-8NUw>