

Introduction to LTE



Raj Jain

Washington University in Saint Louis

Saint Louis, MO 63130

Jain@cse.wustl.edu

Audio/Video recordings of this class lecture are available at:

<http://www.cse.wustl.edu/~jain/cse574-18/>



1. LTE: Key Features
2. OFDMA and SC-FDMA
3. Evolved Packet Core (EPC)
4. LTE Frame Structure
5. Resource Allocation

LTE: Key Features

Long Term Evolution. 3GPP Release 8, 2009.

1. **3.9G** (Pre-4G) cellular technology
Sold as 4G by some providers.
4G=International Mobile Telecommunication (IMT) Advanced Requirements in ITU M.2134-2008
2. **Many different bands:** 700/1500/1700/**2100**/2600 MHz
3. **Flexible Bandwidth:** 1.4/3/5/10/15/20 MHz
4. Frequency Division Duplexing (FDD) and Time Division Duplexing (TDD)
⇒ Both *paired* and *unpaired* spectrum
5. 4x4 MIMO, Multi-user collaborative MIMO
6. Beamforming in the downlink

Ref: A. Ghosh, J. Zhang, J. G. Andrews, R. Muhamed, "Fundamentals of LTE," Prentice Hall, 2010, ISBN: 0137033117, 464 pp. Safari book.

LTE: Key Features (Cont)

8. Data Rate: 326 Mbps/down 86 Mbps up (4x4 MIMO 20 MHz)
9. Modulation: OFDM with QPSK, 16 QAM, 64 QAM
10. **OFDMA** downlink,
Single Carrier Frequency Division Multiple Access (**SC-FDMA**) uplink
11. **Hybrid ARQ** Transmission
12. Short **Frame Sizes** of 10ms and 1ms \Rightarrow faster feedback and better efficiency at high speed
13. **Persistent scheduling** to reduce control channel overhead for low bit rate voice transmission.
14. **IP based** flat network architecture

OFDMA Downlink

- Transmitter at Base Station: IFFT converts frequency to time

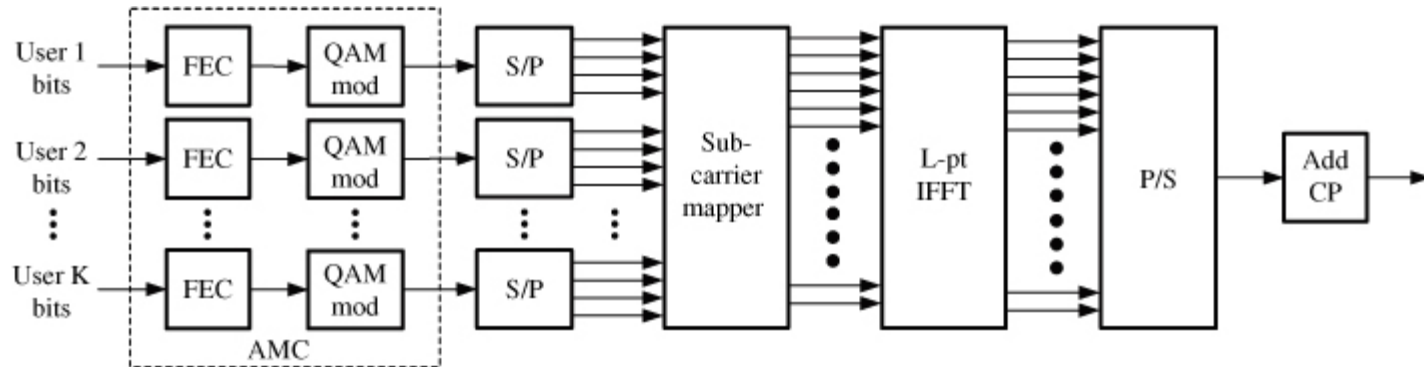

- Receiver at User Terminal: FFT converts time to frequency

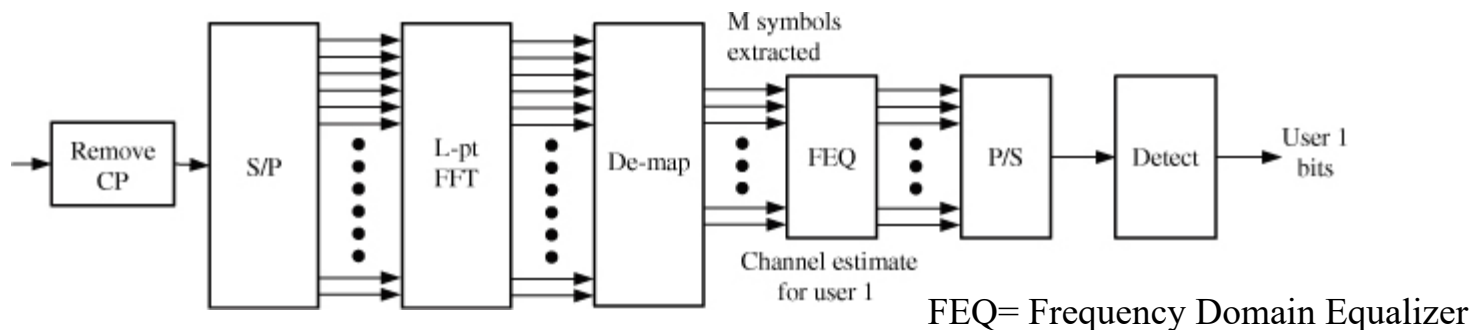

Ref: A. Ghosh, J. Zhang, J. G. Andrews, R. Muhamed, "Fundamentals of LTE," Prentice Hall, 2010, ISBN: 0137033117, 464 pp. Safari book.

Peak-to-Average Power Ratio (PAPR)

- ❑ OFDM
 - ⇒ Each carrier modulated according to specific channel condition
 - ⇒ High variation of power levels
 - ⇒ Higher Peak-to-Average Power Ratio (PAPR)
 - ⇒ Higher cost of amplifiers
- ❑ Amplifiers are linear only over a restricted region
 - ⇒ Costly amplifier or reduce average signal power significantly
 - ⇒ Can afford such amplifiers in Base stations but not in mobiles

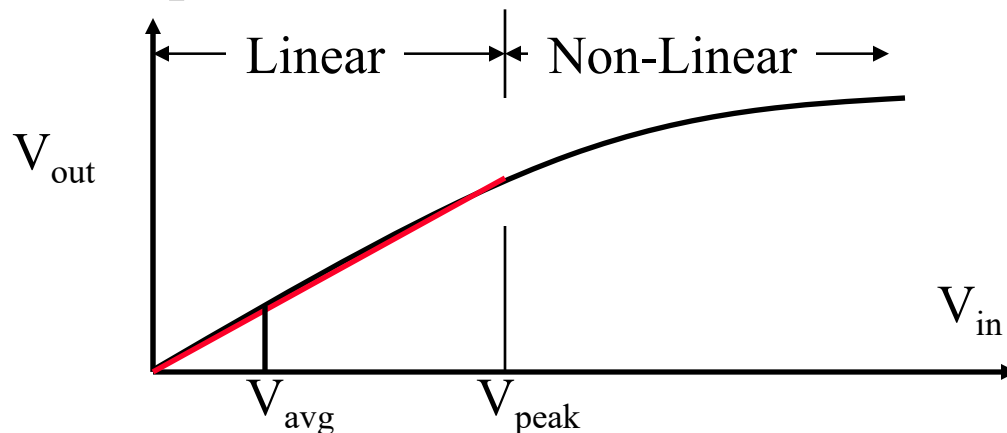

SC-FDMA

- ❑ Single-Carrier Frequency Division Multiple Access
- ❑ Each user gets a contiguous part of the channel



- ❑ Uses single carrier modulation and adds a cyclic prefix
- ❑ Single carrier \Rightarrow Not much variation in amplitude
 \Rightarrow Lower PAPR
- ❑ Better for uplink because slight mis-synchronization among users does not affect the decoding significantly
- ❑ With OFDMA each user's subcarriers are spread all over the band and may affect other users subcarriers all over the band

SC-FDMA (Cont)

- ❑ In practice, SC-FDMA is implemented as if the user is allocated a contiguous subset of subcarriers
- ❑ Transmitter at the User Terminal:

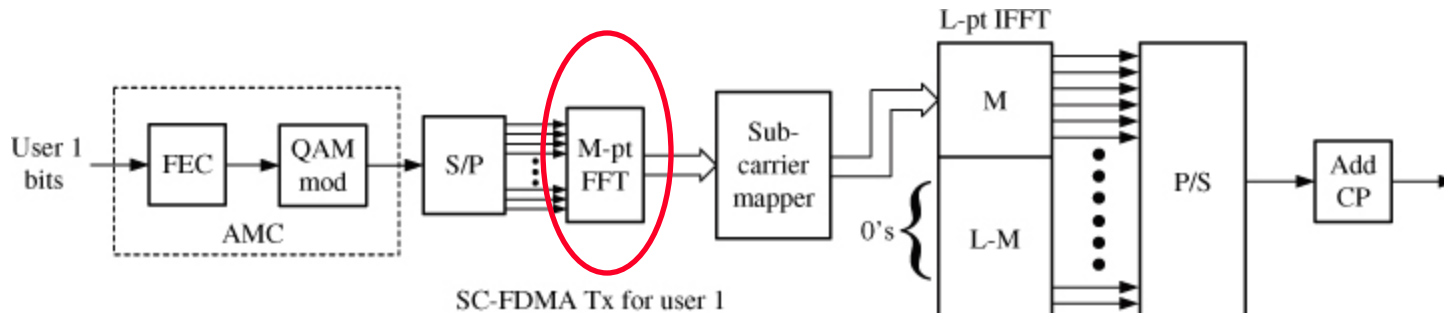

- ❑ Receiver at the Base Station:

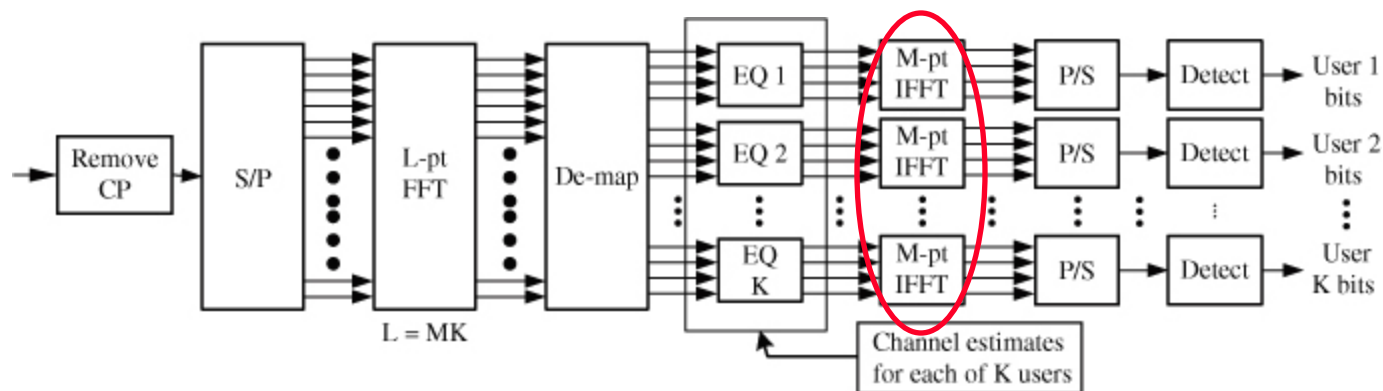

- ❑ SC-FDMA = Discrete Fourier Transform *Pre-coded* OFDMA

Ref: A. Ghosh, J. Zhang, J. G. Andrews, R. Muhamed, "Fundamentals of LTE," Prentice Hall, 2010, ISBN: 0137033117, 464 pp.

Washington University in St. Louis

<http://www.cse.wustl.edu/~jain/cse574-18/>

©2018 Raj Jain

Space Time Block Codes (STBC)

- ❑ Invented 1998 by Vahid Tarokh.
- ❑ Transmit multiple redundant copies from multiple antennas
- ❑ Precisely coordinate distribution of symbols in space and time.
- ❑ Receiver combines multiple copies of the received signals optimally to overcome multipath.
- ❑ Example: Two antennas: Two symbols in two slots \Rightarrow Rate 1

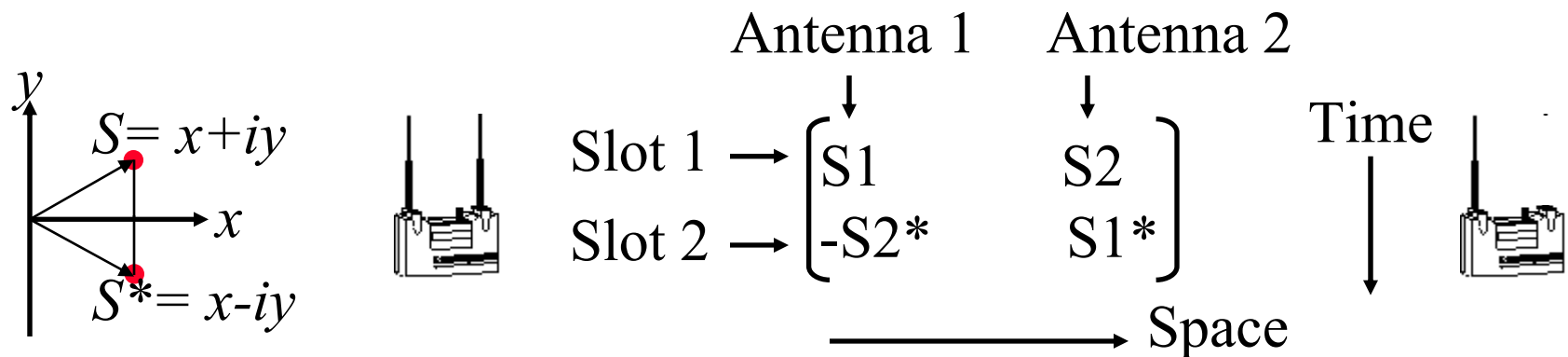

$S1^*$ is complex conjugate of $S1 \Rightarrow$ columns are orthogonal

Space-Frequency Block Codes

- STBC on OFDM (Multi-carrier): Two alternatives
- STBC on each subcarrier:**

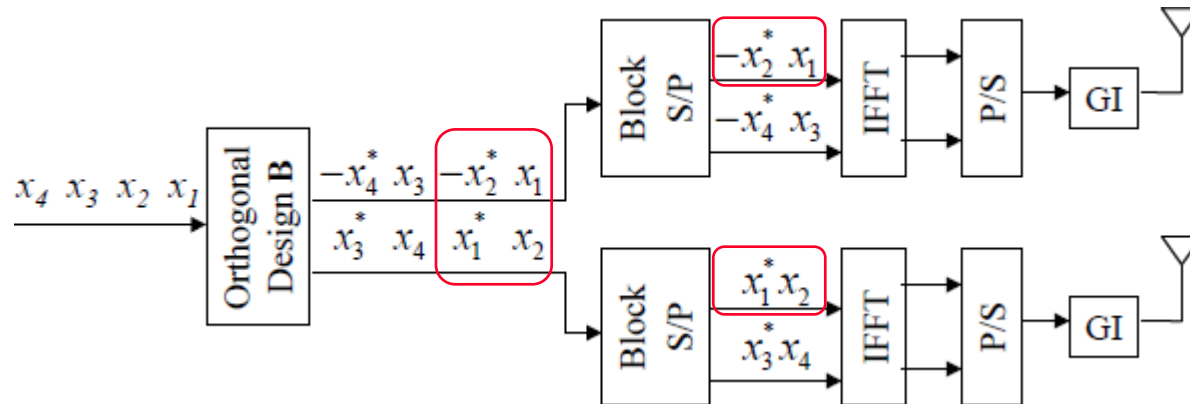

- STBC on across subcarriers (SFBC):** Helps if channel changes fast

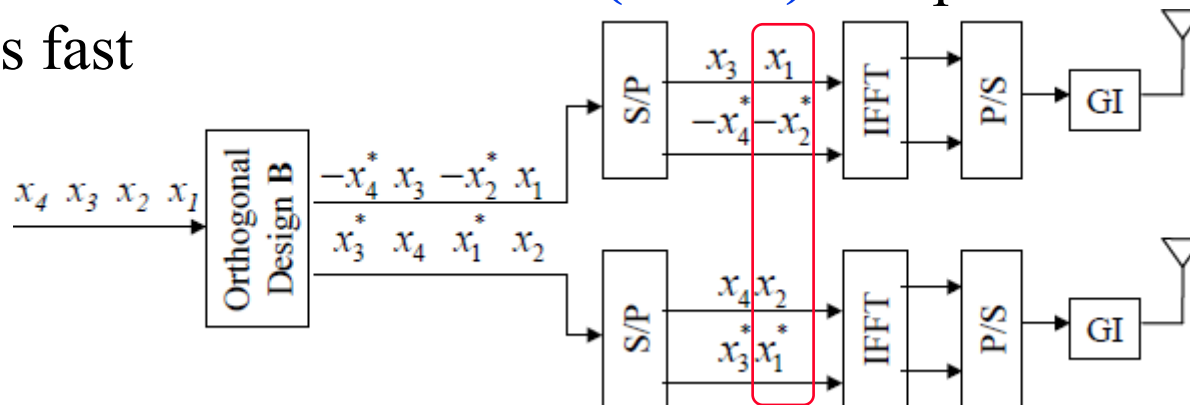

Ref: G. Bauch, "Space-Time Block Codes Versus Space-Frequency Block Codes," IEEE VTC, Apr 2003,
<https://pdfs.semanticscholar.org/105a/06314ba6718f3d698a7620b2e891d20c00de.pdf>

Puncturing

- ❑ Use large number of error correcting code (ECC) bits but send only some of them
- ❑ Example: 1/2 code = 1 ECC bit/Original bit
- ❑ Or 4 bits for each 2-bit symbol
- ❑ 1/4 puncturing \Rightarrow Drop every 4th bit
 \Rightarrow send 3 bits for each 2-bit symbol = 2/3 code
- ❑ Receiver puts random bits in the punctured positions and decodes \Rightarrow high probability of correct decoding particularly if the SINR is high
- ❑ 1/2 code with 1/4th puncture is not as good as 2/3 code in general but puncturing helps in some situations, such as, H-ARQ

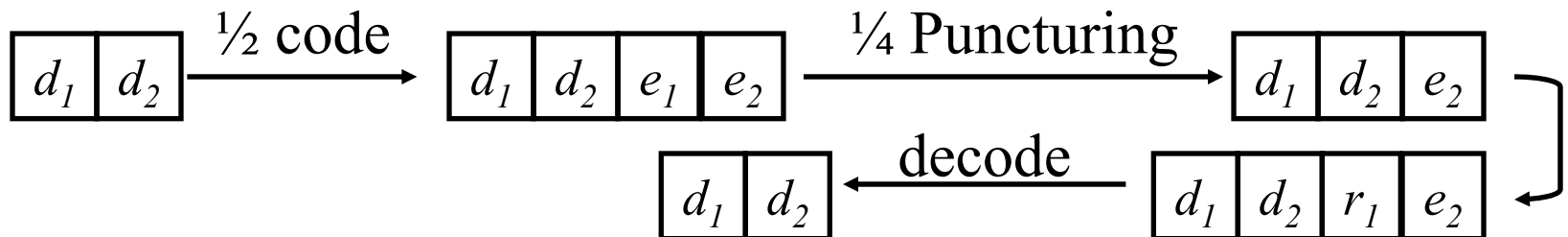

ARQ

- ❑ Automatic Repeat reQuest (ARQ)
- ❑ Retransmit a packet if it is received in error
- ❑ Previous (bad) bits are discarded.

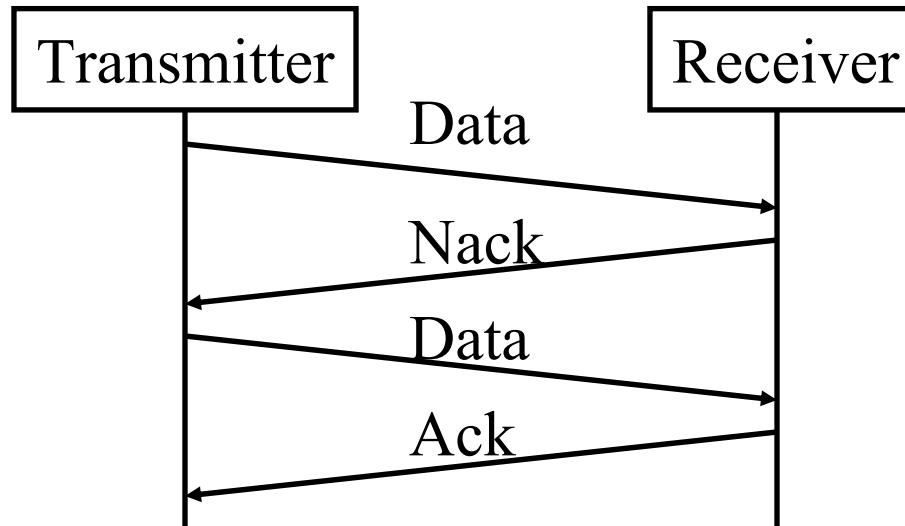

Hybrid ARQ

- ❑ PHY and MAC layers work together \Rightarrow Hybrid
- ❑ PHY layer sends some bits first (uses puncturing)
 - Sends additional bits only if necessary.
 - Additional bits are sent until the decoding is successful. (**Incremental Redundancy** or **Type II H-ARQ**)
 - Another alternative is to combine the good bits of multiple transmissions (**Chase Combining** or **Type I H-ARQ**)

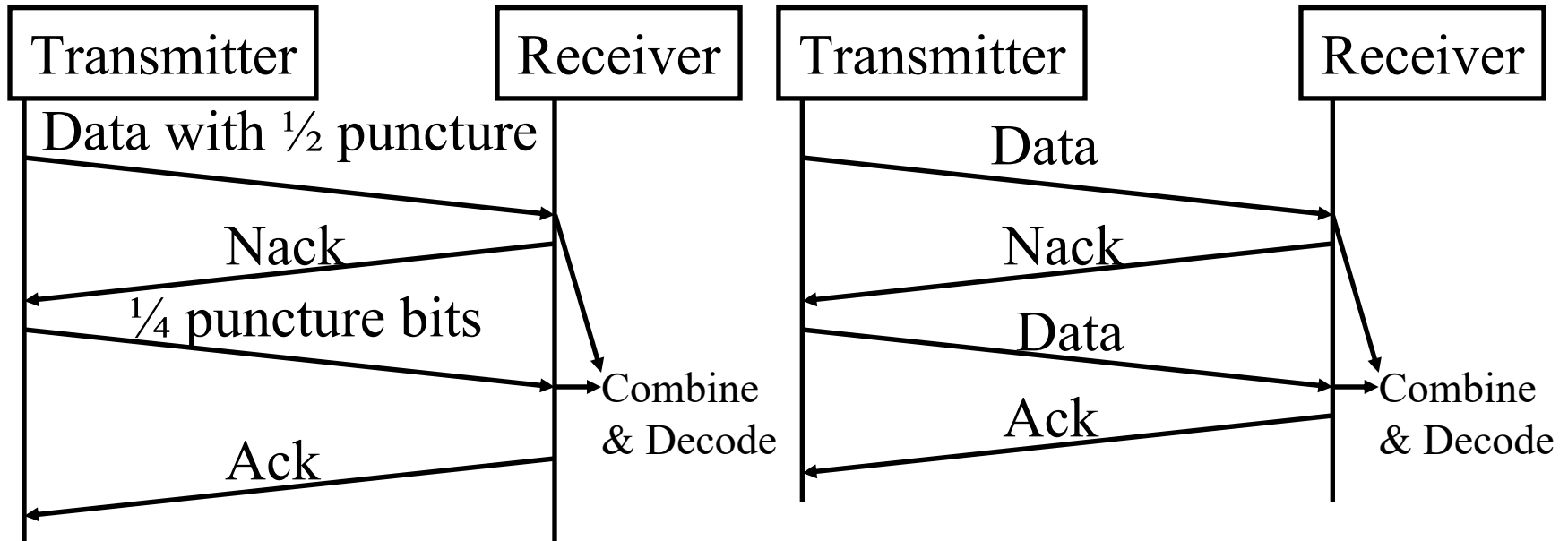

IP-Based Flat Network Architecture

- ❑ Flat \Rightarrow Less hierarchical and fewer nodes
- ❑ All services (Voice/multimedia) over IP
- ❑ For backward compatibility some non-IP protocols and services are still used in LTE network

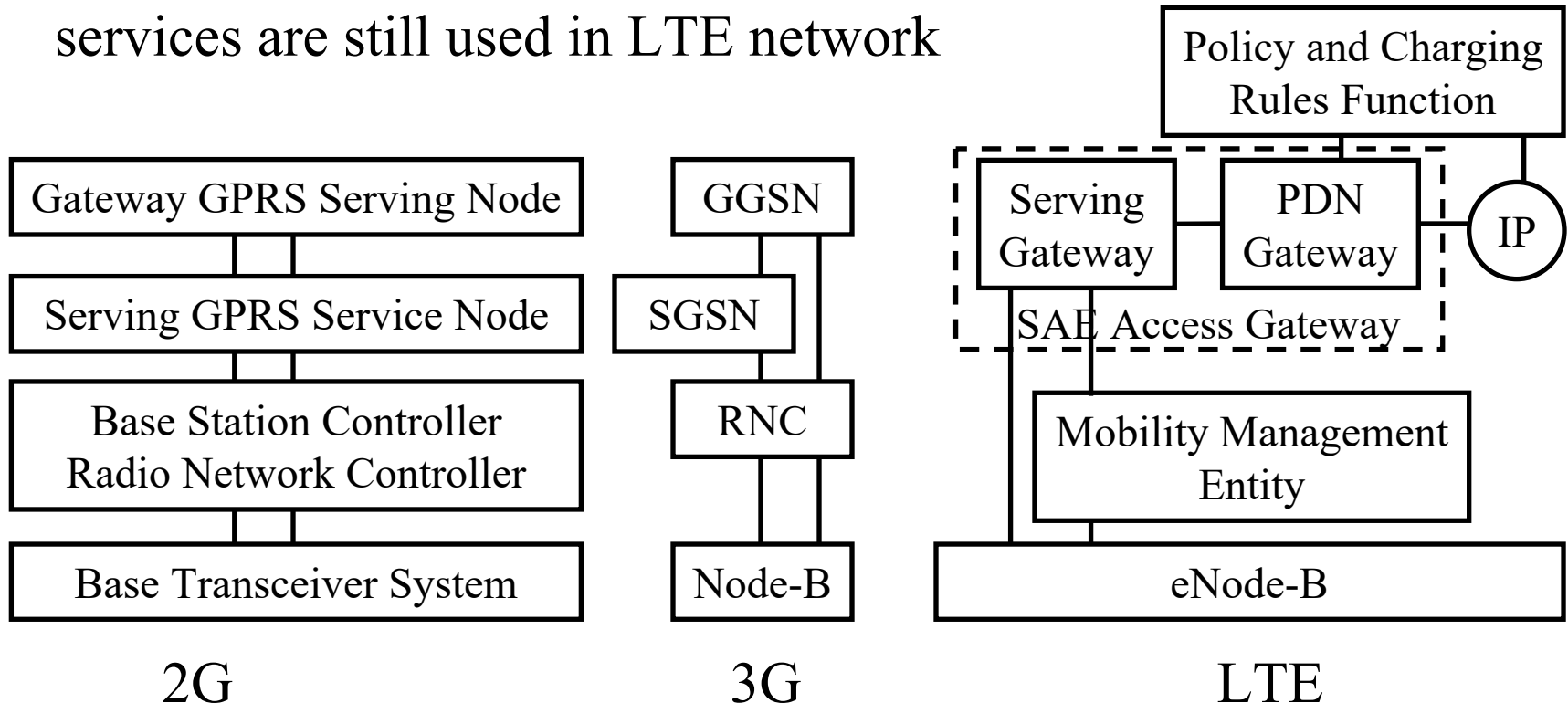

Evolved Packet Core (EPC)

□ Four new elements:

1. **Serving Gateway**: Demarcation point between RAN and Core. Serves as mobility anchor when terminals move
2. **Packet Data network Gateway (PGW)**: Termination of EPC towards Internet or IMS network. IP services, address allocation, deep packet inspection, policy enforcement
3. **Mobility Management Entity (MME)**: Location tracking, paging, roaming, and handovers. All control plane functions related to subscriber and session management.
4. **Policy and Charging Rules Function (PCRF)**: Manages QoS

Evolved Packet System (EPS)

Radio Access Network

Serving Network Core Network

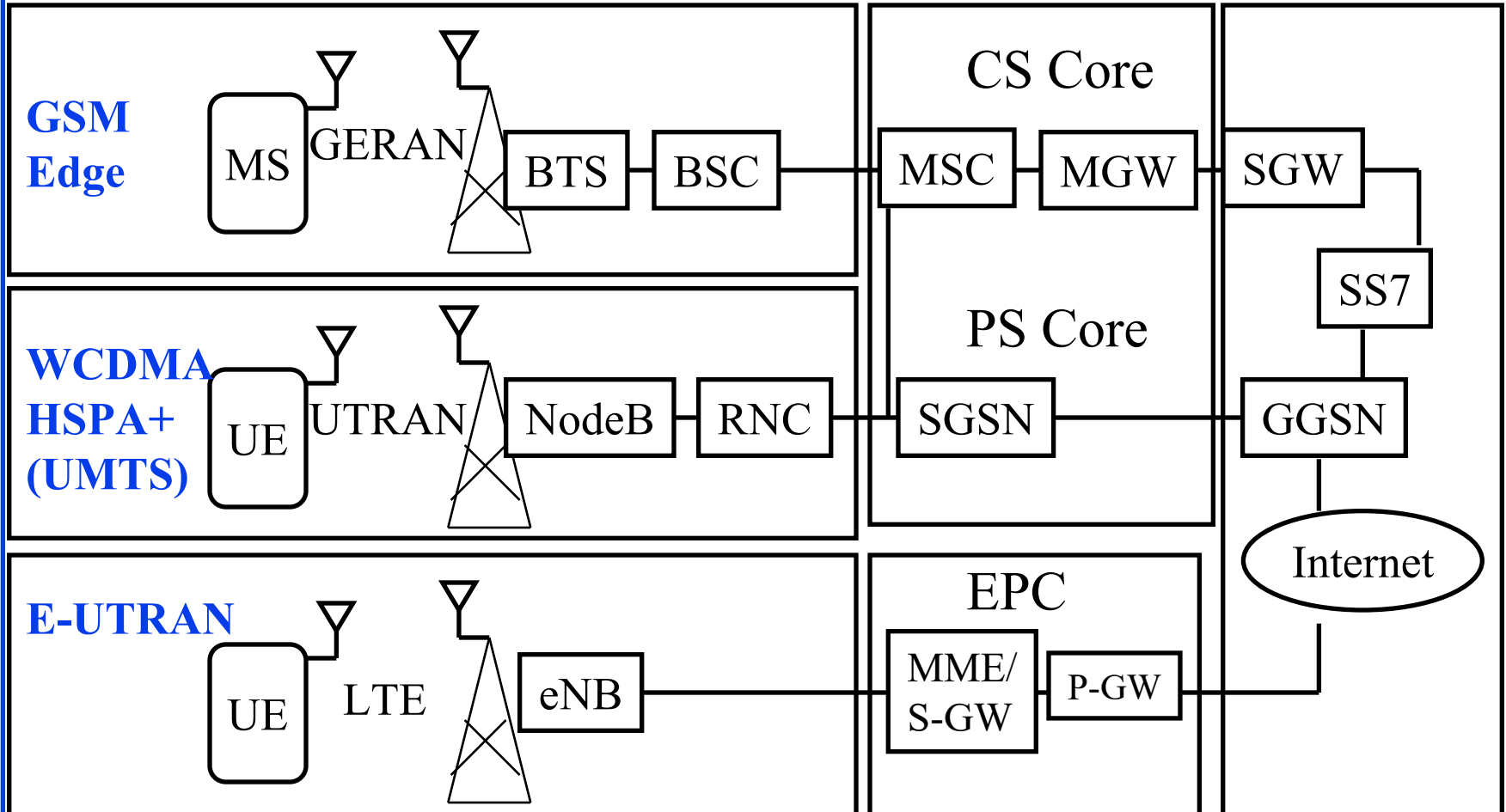

Evolved Packet System (Cont)

- ❑ CS = Circuit Switched
- ❑ EPC = Evolved Packet Core
- ❑ EPS = Evolved Packet System
- ❑ GERAN = GSM Enhanced Radio Access Network
- ❑ GGSN = Gateway GPRS Support Node
- ❑ LTE = Long Term Evolution
- ❑ MME = Mobility Management Utility
- ❑ MSC = Mobile Switching Center
- ❑ P-GW = Packet Gateway
- ❑ PS = Packet Switched
- ❑ RNC = Radio Network Control
- ❑ S-GW = Serving Gateway
- ❑ SGSN = Service GPRS Support Node
- ❑ SS7 = System 7
- ❑ eNB = Evolved NodeB

LTE Frame Structure

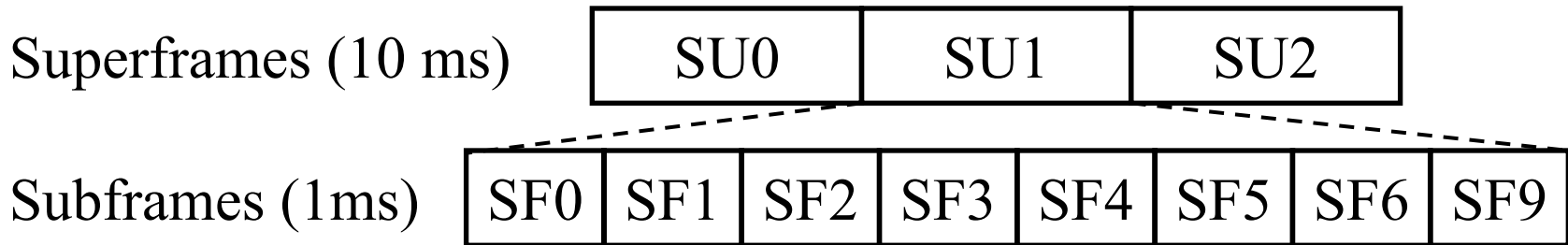

- ❑ Subframe = 2 slots of 0.5 ms each
- ❑ Slot = 6 or 7 symbols of 0.667 ms each
- ❑ Normal Cyclic Prefix: 5.2 us for 1st symbol, 4.7 us for others



- ❑ Extended Cyclic Prefix: for larger networks. 16.7 us

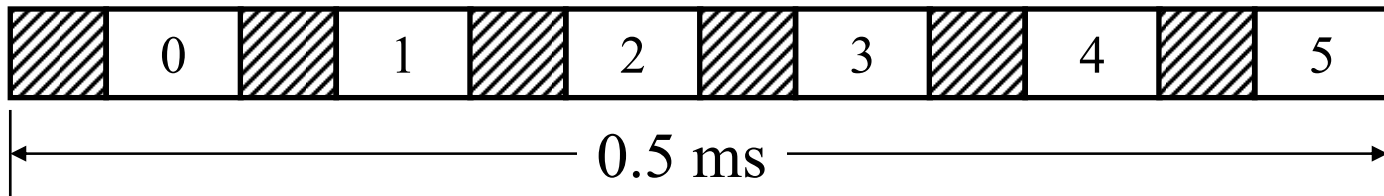

Ref: Rhode and Schwarz, "UMTS Long Term Evolution (LTE) Technology Introduction,"

http://www.rohde-schwarz.de/file/1MA111_4E_LTE_technology_introduction.pdf

Washington University in St. Louis

<http://www.cse.wustl.edu/~jain/cse574-18/>

©2018 Raj Jain

Resource Allocation

- ❑ **Time slot:** 0.5 ms
6 or 7 OFDM symbols
- ❑ **Subcarriers:** 15 kHz
- ❑ **Physical Resource Block:**
12 subcarriers (180 kHz)
over 1 time slot
- ❑ **Minimum Allocation:** 2 PRBs
per subframe

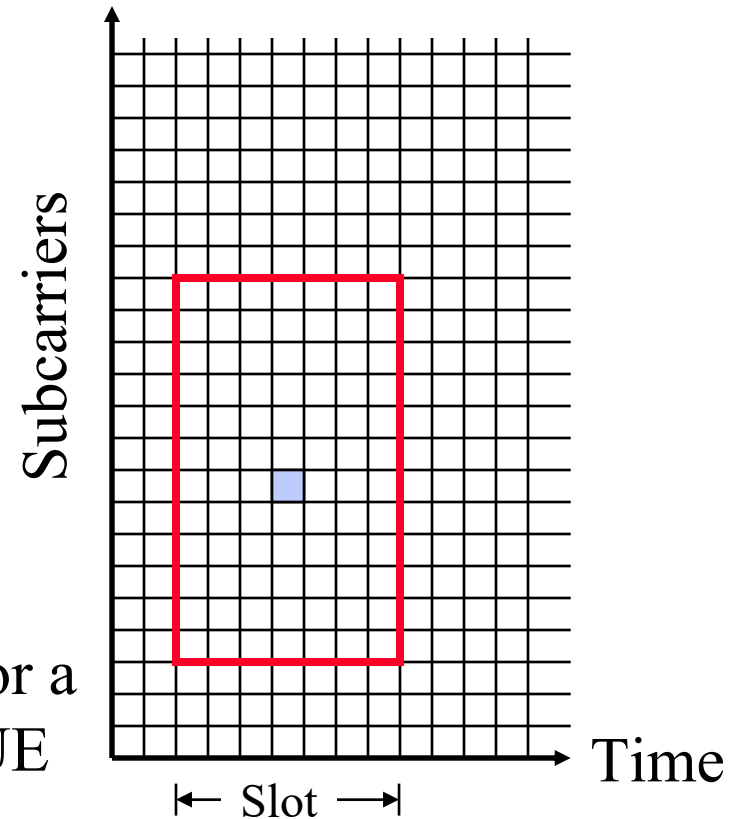
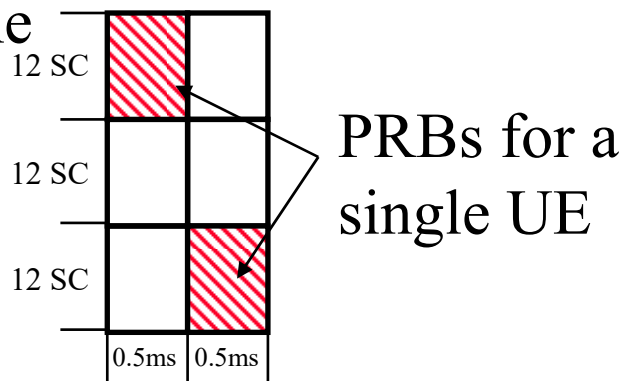

Ref: A. Ghosh, J. Zhang, J. G. Andrews, R. Muhamed, "Fundamentals of LTE," Prentice Hall, 2010, ISBN: 0137033117, 464 pp.

Washington University in St. Louis

<http://www.cse.wustl.edu/~jain/cse574-18/>

©2018 Raj Jain

WiMAX vs. LTE



- ❑ Similar with very minor differences
- ❑ Net Head vs. Bell Head
- ❑ Enterprise Networking vs. Carrier Networking
- ❑ Academic vs. Telecom
- ❑ Intel/Google vs. Ericsson/QUALCOMM
- ❑ Both use OFDMA.
Both are incompatible with 2G and 3G (CDMA) radios.
- ❑ Quad-band \Rightarrow Penta-band

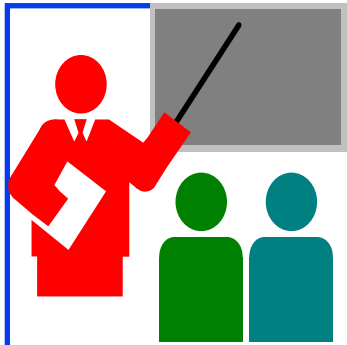

Summary

1. WiMAX and LTE are pre-4G technologies.
2. WiMAX and LTE have numerous **common features**: Many bands, flexible bandwidth, FDD/TDD. MIMO/Beamforming H-ARQ, IP-Based, OFDMA. The key differentiator is SC-FDMA for uplink in LTE to reduce **PAPR**.
3. STBC requires transmitting redundant symbols from multiple antenna. **SFBC** require that these redundant symbols be sent on different subcarriers.
4. **Puncturing** allows some ECC bits to be not transmitting. This is used in **H-ARQ** to send extra bits only if necessary.
5. LTE uses a **super-frame** of 10 subframes of 1 ms each. Each **subframe** has one **slot** for uplink and downlink each.

Reading List

- ❑ A. Ghosh, J. Zhang, J. G. Andrews, R. Muhamed, "Fundamentals of LTE," Prentice Hall, 2010, ISBN: 0137033117, 464 pp., Safari Book.
- ❑ 3GPP, "LTE," <http://www.3gpp.org/technologies/keywords-acronyms/98-lte>
- ❑ 3GPP, "The Evolved Packet Core," <http://www.3gpp.org/technologies/keywords-acronyms/100-the-evolved-packet-core>
- ❑ Rhode and Schwarz, "UMTS Long Term Evolution (LTE) Technology Introduction," http://www.rohde-schwarz.de/file/1MA111_4E_LTE_technology_introduction.pdf

Wikipedia Links

- ❑ <https://en.wikipedia.org/wiki/IMT-Advanced>
- ❑ <https://en.wikipedia.org/wiki/4G>
- ❑ https://en.wikipedia.org/wiki/Radio_Resource_Control
- ❑ https://en.wikipedia.org/wiki/Radio_resource_management
- ❑ https://en.wikipedia.org/wiki/Single-carrier_FDMA
- ❑ https://en.wikipedia.org/wiki/Space%E2%80%93time_block_code
- ❑ https://en.wikipedia.org/wiki/Space-time_block_coding_based_transmit_diversity
- ❑ https://en.wikipedia.org/wiki/Space%E2%80%93time_code
- ❑ https://en.wikipedia.org/wiki/Spatial_multiplexing
- ❑ https://en.wikipedia.org/wiki/Multi-user_MIMO
- ❑ https://en.wikipedia.org/wiki/Transmit_diversity
- ❑ https://en.wikipedia.org/wiki/Mobility_management
- ❑ <https://en.wikipedia.org/wiki/MIMO>
- ❑ https://en.wikipedia.org/wiki/Multi-user_MIMO
- ❑ <https://en.wikipedia.org/wiki/Precoding>

Wikipedia Links (Cont)

- ❑ https://en.wikipedia.org/wiki/Antenna_diversity
- ❑ https://en.wikipedia.org/wiki/Many_antennas
- ❑ https://en.wikipedia.org/wiki/Multi-user_MIMO
- ❑ https://en.wikipedia.org/wiki/Smart_antenna
- ❑ <https://en.wikipedia.org/wiki/Beamforming>
- ❑ <https://en.wikipedia.org/wiki/Precoding>
- ❑ https://en.wikipedia.org/wiki/Radio_Network_Controller
- ❑ https://en.wikipedia.org/wiki/Crest_factor
- ❑ <https://en.wikipedia.org/wiki/PDCP>
- ❑ https://en.wikipedia.org/wiki/Crest_factor
- ❑ <https://en.wikipedia.org/wiki/E-UTRA>
- ❑ https://en.wikipedia.org/wiki/Policy_and_charging_rules_function
- ❑ <https://en.wikipedia.org/wiki/Puncturing>
- ❑ <https://en.wikipedia.org/wiki/Fading>
- ❑ https://en.wikipedia.org/wiki/Single-frequency_network
- ❑ https://en.wikipedia.org/wiki/Evolved_Packet_System

Wikipedia Links (Cont)

- ❑ https://en.wikipedia.org/wiki/Channel_allocation_schemes
- ❑ https://en.wikipedia.org/wiki/Hybrid_automatic_repeat_request
- ❑ https://en.wikipedia.org/wiki/LTE_timeline
- ❑ https://en.wikipedia.org/wiki/Flat_IP
- ❑ <https://en.wikipedia.org/wiki/E-UTRA>
- ❑ https://en.wikipedia.org/wiki/Mobility_Management_Entity
- ❑ https://en.wikipedia.org/wiki/System_Architecture_Evolution
- ❑ <https://en.wikipedia.org/wiki/EnodeB>
- ❑ https://en.wikipedia.org/wiki/Signaling_gateway
- ❑ https://en.wikipedia.org/wiki/Packet_data_serving_node
- ❑ https://en.wikipedia.org/wiki/Automatic_repeat_request
- ❑ https://en.wikipedia.org/wiki/Hybrid_automatic_repeat_request
- ❑ <https://en.wikipedia.org/wiki/Beamforming>
- ❑ https://en.wikipedia.org/wiki/Multimedia_Broadcast_Multicast_Service
- ❑ https://en.wikipedia.org/wiki/Broadcast/Multicast_Control
- ❑ https://en.wikipedia.org/wiki/Multicast-broadcast_single-frequency_network

Wikipedia Links (Cont)

- ❑ https://en.wikipedia.org/wiki/Orthogonal_frequency_division_multiple_access
- ❑ https://en.wikipedia.org/wiki/Single-carrier_FDMA
- ❑ <https://en.wikipedia.org/wiki/4G>
- ❑ https://en.wikipedia.org/wiki/Orthogonal_frequency_division_multiplexing
- ❑ https://en.wikipedia.org/wiki/Orthogonal_frequency_division_multiple_access
- ❑ <https://en.wikipedia.org/wiki/E-UTRA>
- ❑ https://en.wikipedia.org/wiki/Cooperative_MIMO
- ❑ https://en.wikipedia.org/wiki/Cyclic_prefix

LTE References

- ❑ Agilent Technologies, “LTE and the Evolution to 4G Wireless,” Wiley, 2009, ISBN:0470682616
- ❑ E. Dahlman, et al, “3G Evolution:HSPA and LTE for Mobile Broadband,” 2nd Edition, Academic Press, 2008, ISBN:0123745385
- ❑ 3GPP TS 36.104, “Evolved Universal Terrestrial Radio Access (E-UTRA); Base Station (BS) radio transmission and reception (Release 8) ”
- ❑ 3GPP TR 25.913., “Requirements for Evolved UTRA (E-UTRA) and Evolved UTRAN (E-UTRAN),” v8.0.0, December 2008.
- ❑ ITU-R Report M.2134, “Requirements Related to Technical Performance for IMT-Advanced Radio Interface(s),” November 2008.
- ❑ 3GPP TR 36.913, “Requirements for Further Advancements for E-UTRA,” v8.0.1, March 2009.
- ❑ S. Sesia, I. Toufik, "LTE – The UMTS Long Term Evolution From Theory to Practice, Second Edition," Wiley , 2011, ISBN: 9780470660256, 792 pp. Safari book.

Acronyms

- ❑ 3GPP 3rd Generation Partnership Project
- ❑ ARQ Automatic Repeat Request
- ❑ BPSK Binary Phase Shift Keying
- ❑ BSC Base Station Controller
- ❑ BTS Base Transceiver Station
- ❑ CDMA Code Division Multiple Access
- ❑ CS Circuit Switched
- ❑ ECC Error Correcting Code
- ❑ eNB Enhanced Node B
- ❑ eNode-B Enhanced Node B
- ❑ EPC Evolved Packet Core
- ❑ EPS Evolved Packet System
- ❑ FDD Frequency Division Duplexing
- ❑ FDMA Frequency Division Multiple Access
- ❑ FEQ Frequency Domain Equalizer
- ❑ FFT Fast Fourier Transform

Acronyms (Cont)

- ❑ FSTD Frequency-Shift Transmit Diversity
- ❑ GERAN GSM/EDGE Radio Access Network
- ❑ GGSN Gateway GPRS Support
- ❑ GPRS General Packet Radio Service
- ❑ GSM Global System for Mobile Communications
- ❑ GW Gateway
- ❑ HSPA High-Speed Packet Access
- ❑ IEEE Institution of Electrical and Electronic Engineers
- ❑ IMS Internet Multimedia System
- ❑ IMT-Advanced International Mobile Telecommunications Advanced
- ❑ IP Internet Protocol
- ❑ ITU International Telecommunications Union
- ❑ kHz Kilo Hertz
- ❑ LTE Long Term Evolution
- ❑ MAC Message Authentication Code
- ❑ MBMS Multicast-Broadcast Mobile Services

Acronyms (Cont)

- ❑ MGW Media Gateway
- ❑ MHz Mega Hertz
- ❑ MIMO Multiple Input Multiple Output
- ❑ MME Mobility Management Entity
- ❑ MS Mobile Station
- ❑ MSC Mobile Switching Center
- ❑ OFDM Orthogonal Frequency Division Modulation
- ❑ OFDMA Orthogonal Frequency Division Multiple Access
- ❑ PAPR Peak-to-Average Power Ratio
- ❑ PCRF Policy and Charging Rules Function
- ❑ PDFICH Physical Control Format Indicator Channel
- ❑ PDN Packet Data Network
- ❑ PGW Packet Data network Gateway
- ❑ PHY Physical Layer
- ❑ PS Packet Switched
- ❑ QAM Quadrature Amplitude Modulation

Acronyms (Cont)

- ❑ QoS Quality of Service
- ❑ QPSK Quadrature Phase Shift Keying
- ❑ RAN Radio Access Network
- ❑ RNC Radio Network Control
- ❑ SAE Service Access Gateway
- ❑ SC-FDMA Single Carrier Frequency Division Multiple Access
- ❑ SC Single Carrier
- ❑ SF Subframe
- ❑ SFBC Space Frequency Block Code
- ❑ SGSN Service GPRS Support
- ❑ SGW Serving Gateay
- ❑ SINR Signal to Interference and Noise Ratio
- ❑ SN Sequence Number
- ❑ SNR Signal-to-noise ratio
- ❑ SOstart Begining of Segment

Acronyms (Cont)

- ❑ STBC Space Time Block Code
- ❑ SU Superframe
- ❑ TD-SCDMA Time Division Synchronous Code Division Multiple Access
- ❑ TDD Time Division Duplexing
- ❑ TDMA Time Division Multiple Access
- ❑ UE User Element
- ❑ UMTS Universal Mobile Telecommunications System
- ❑ UTRAN UMTS Terrestrial Radio Access Network
- ❑ VTC Vehicular Technology Conference
- ❑ WCDMA Wideband Code Division Multiple Access
- ❑ WiMAX Worldwide Interoperability for Microwave Access

Scan This to Download These Slides



Raj Jain

<http://rajjain.com>

Related Modules



CSE567M: Computer Systems Analysis (Spring 2013),
https://www.youtube.com/playlist?list=PLjGG94etKypJEKjNAa1n_1X0bWWNyZcof

CSE473S: Introduction to Computer Networks (Fall 2011),
https://www.youtube.com/playlist?list=PLjGG94etKypJWOSPMh8Azcg5e_10TiDw



Recent Advances in Networking (Spring 2013),
<https://www.youtube.com/playlist?list=PLjGG94etKypLHyBN8mOgwJLHD2FFIMGq5>

CSE571S: Network Security (Fall 2011),
<https://www.youtube.com/playlist?list=PLjGG94etKypKvzfVtutHcPFJXumyyg93u>



Video Podcasts of Prof. Raj Jain's Lectures,
<https://www.youtube.com/channel/UCN4-5wzNP9-ruOzQMs-8NUw>