

# Introduction to Wireless Signal Propagation

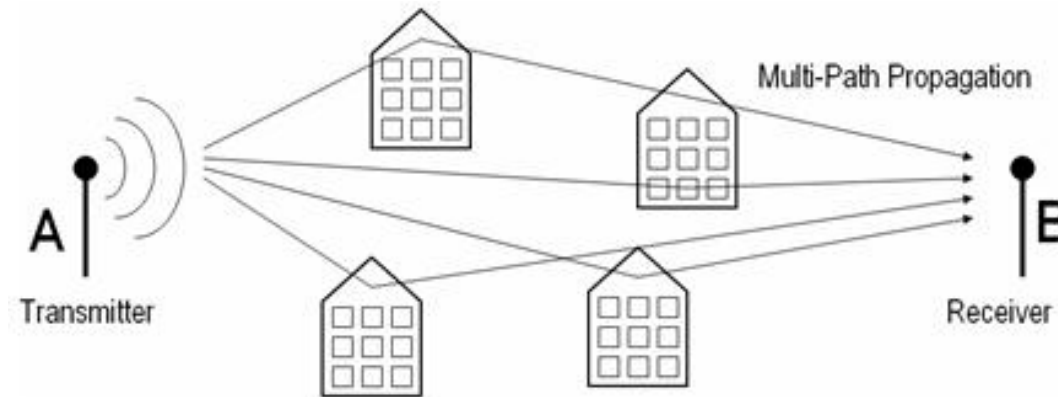

**Raj Jain**

Professor of Computer Science and Engineering  
Washington University in Saint Louis  
Saint Louis, MO 63130  
Jain@cse.wustl.edu

Audio/Video recordings of this class lecture are available at:

<http://www.cse.wustl.edu/~jain/cse574-22/>

**Student Questions**



1. Reflection, Diffraction, Scattering
2. Fading, Shadowing, multipath
3. Fresnel Zones
4. Multi-Antenna Systems, Beam forming, MIMO
5. OFDM

Note: This is the 2<sup>nd</sup> in a series of 2 lectures on wireless physical layer. Modulation, coding, Shannon's theorem, etc were discussed in the other lecture.

## Student Questions

# Wireless Radio Channel

- ❑ Path loss: Depends upon distance and frequency
- ❑ Noise
- ❑ Shadowing: Obstructions
- ❑ Frequency Dispersion (Doppler Spread) due to motion
- ❑ Interference
- ❑ Multipath: Multiple reflected waves
- ❑ Inter-symbol interference (ISI) due to dispersion

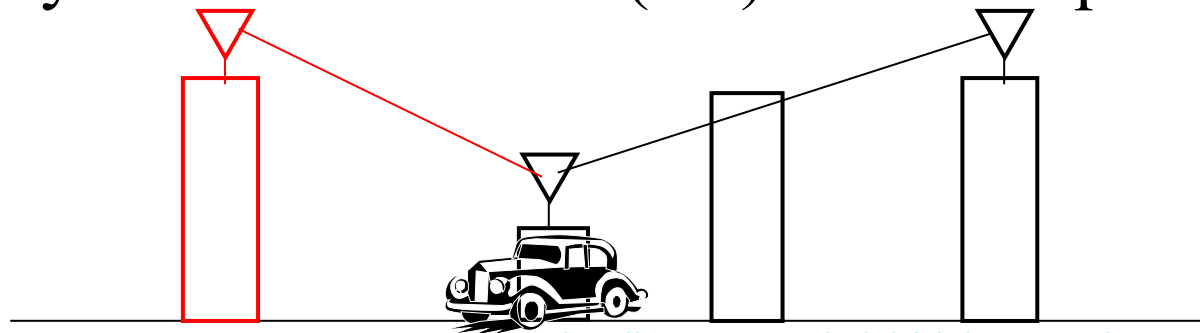

## Student Questions

# Antenna

- ❑ Transmitter converts electrical energy to electromagnetic waves
- ❑ Receiver converts electromagnetic waves to electrical energy
- ❑ Same antenna is used for transmission and reception
- ❑ Omni-Directional: Power radiated in all directions
- ❑ Directional: Most power in the desired direction
- ❑ Isotropic antenna: Radiates in all directions equally
- ❑ Antenna Gain = Power at particular point/Power with Isotropic  
Expressed in dBi

$$P_r = P_t G_t G_r (\lambda/4\pi d)^2$$

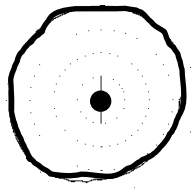

Omni-Directional

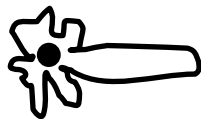

Directional

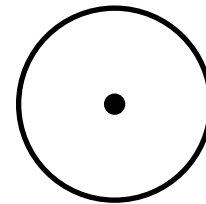

Isotropic

## Student Questions

# Reflection, Diffraction, Scattering

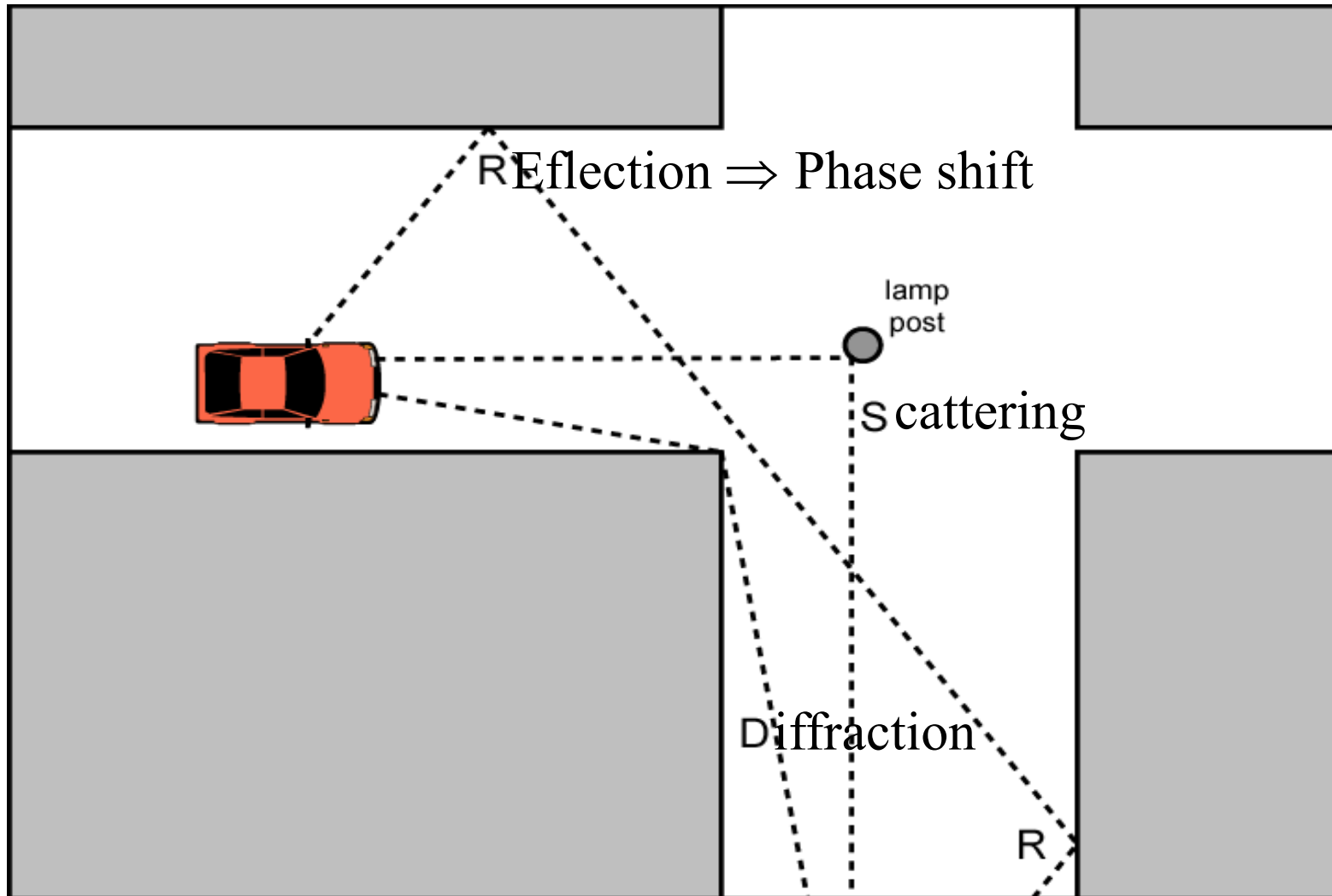

**Student Questions**

# Reflection, Diffraction and Scattering (Cont)

- ❑ **Reflection:** Surface large relative to wavelength of signal
  - May have phase shift from original
  - May cancel out original or increase it
- ❑ **Diffraction:** Edge of impenetrable body that is large relative to  $\lambda$ 
  - May receive signal even if no line of sight (LOS) to transmitter
- ❑ **Scattering**
  - Obstacle size on order of wavelength. Lamp posts etc.
- ❑ If LOS, diffracted and scattered signals not significant
  - Reflected signals may be
- ❑ If no LOS, diffraction and scattering are primary means of reception

## Student Questions

# Channel Model

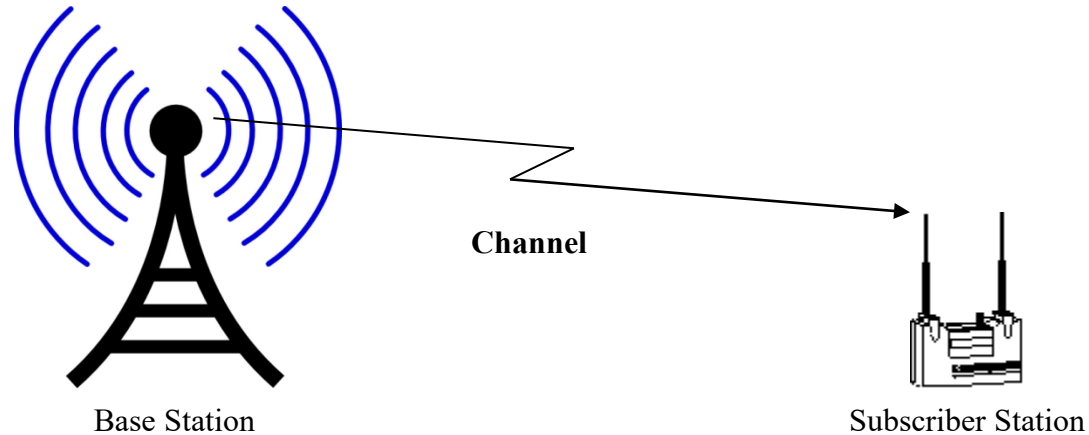

- ❑ Power profile of the received signal can be obtained by *convolving* the power profile of the transmitted signal with the impulse response of the channel.
- ❑ Convolution in time = multiplication in frequency
- ❑ Signal  $x$ , after propagation through the channel  $H$  becomes  $y$ :
$$y(f) = H(f)x(f) + n(f)$$
- ❑ Here  $H(f)$  is **channel response**, and  $n(f)$  is the noise. Note that  $x$ ,  $y$ ,  $H$ , and  $n$  are all functions of the signal frequency  $f$ .

## Student Questions

# Path Loss

- ❑ Power is distributed equally to spherical area  $4\pi d^2$
- ❑ The received power depends upon the wavelength
- ❑ If the Receiver collects power from area  $A_R$ :

$$P_R = P_T G_T \frac{1}{4\pi d^2} A_R$$

- ❑ Receiving Antenna Gain

$$G_R = \frac{4\pi}{\lambda^2} A_R$$

$$P_R = P_T G_T G_R \left(\frac{\lambda}{4\pi d}\right)^2$$

- ❑ This is known as **Frii's Law**.  
Attenuation in free space increases with frequency.

## Student Questions



# Multipath

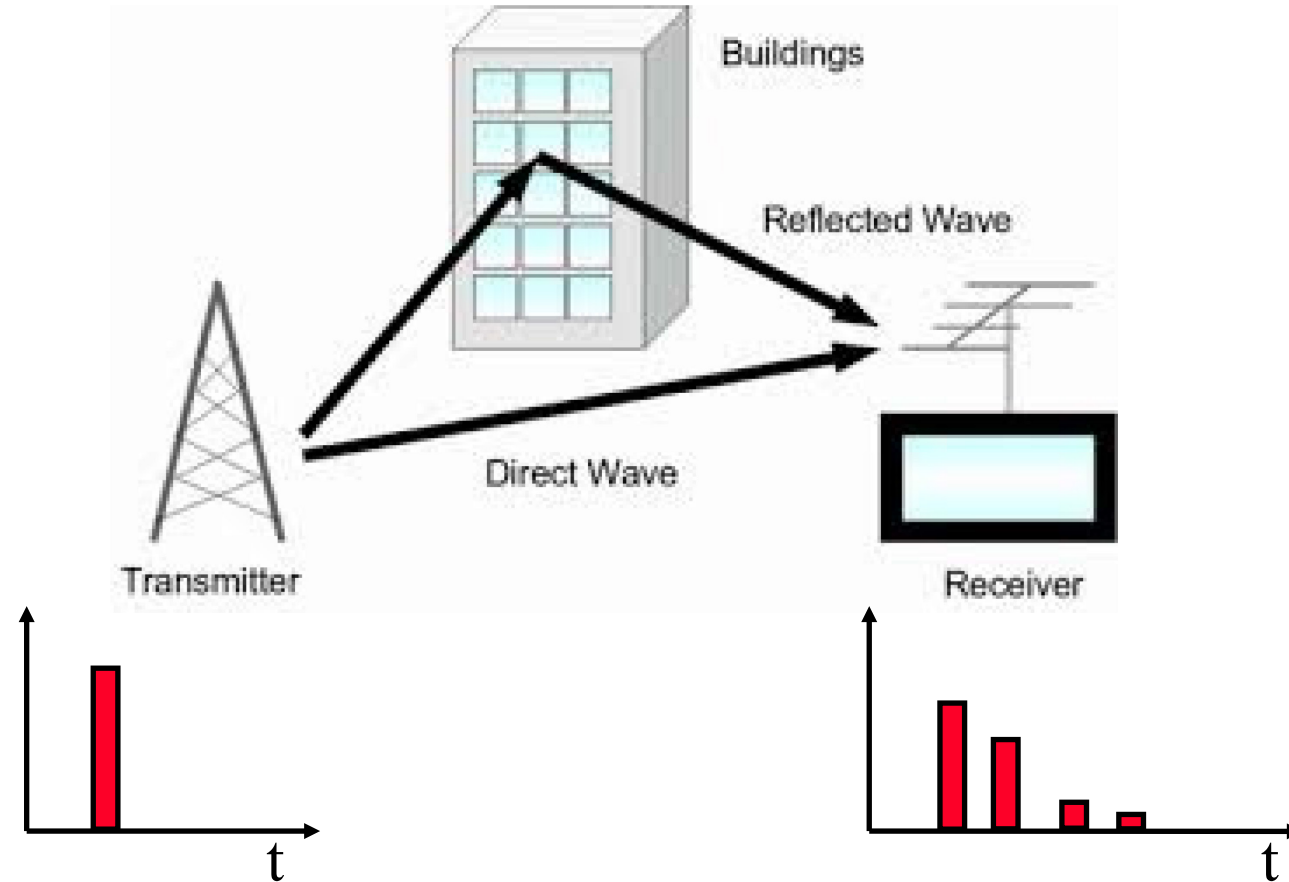

- ❑ Multiple reflected copies of the signal are received

## Student Questions

# Inter-Symbol Interference

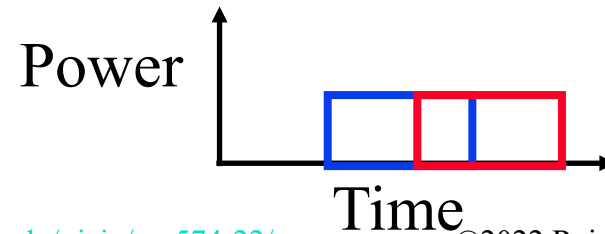
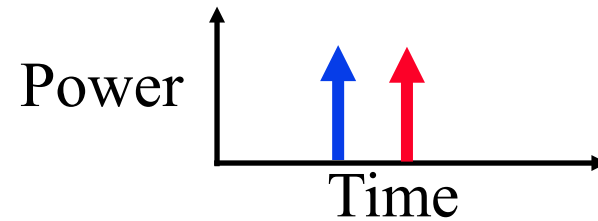
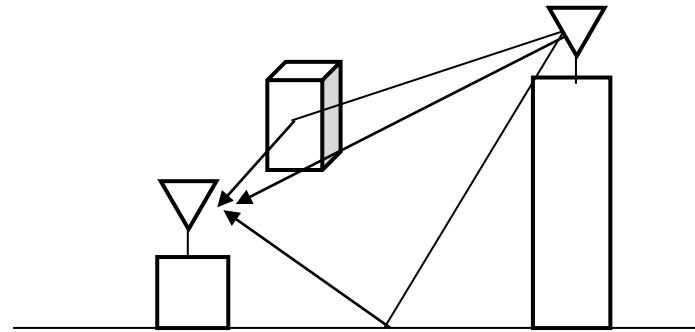

- Symbols become wider  
⇒ Limits the number of bits/s

## Student Questions

# Multipath Propagation

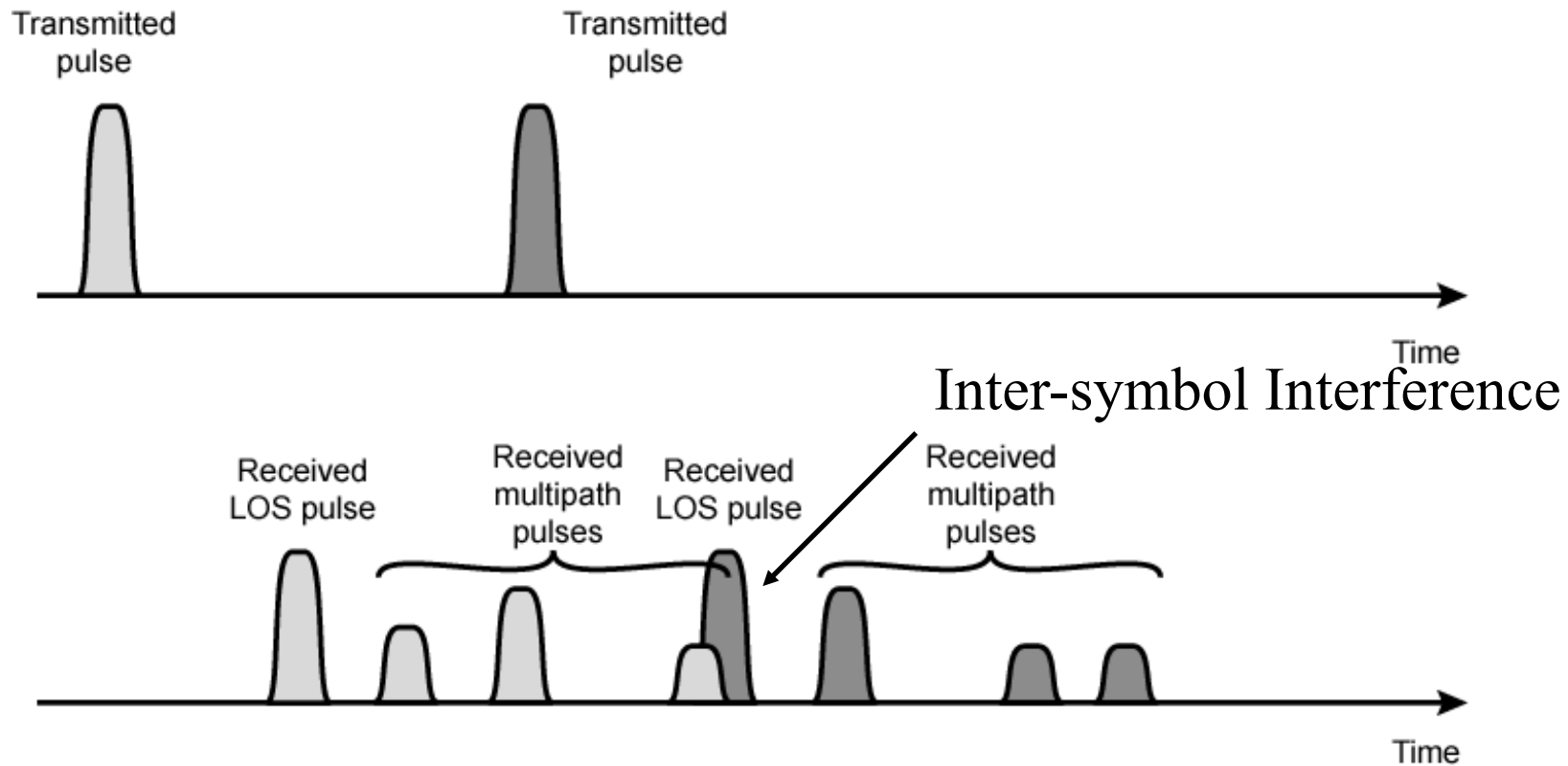

- ❑ Delay Spread = Time between first and last versions of signal
- ❑ Fading: Fluctuation in amplitude, phase or delay spread
- ❑ Multipath may add constructively or destructively  
⇒ Fast fading

## Student Questions

# $d^{-4}$ Power Law

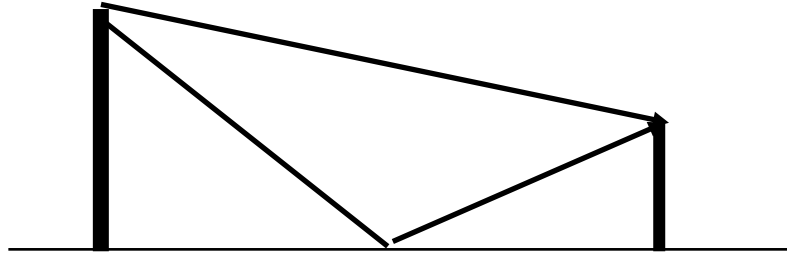

- ❑ Using a two-ray model

$$P_R = P_T G_T G_R \left( \frac{h_t h_r}{d^2} \right)^2$$

- ❑ Here,  $h_T$  and  $h_R$  are heights of transmit and receive antennas
- ❑ It is valid for distances larger than

$$d_{\text{break}} = 4h_T h_R / \lambda$$

- ❑ Note that the received power becomes independent of the frequency.
- ❑ Measured results show  $n=1.5$  to  $5.5$ . Typically  $4$ .

## Student Questions

# Small Scale Fading

- The signal amplitude can change by moving a few inches  $\Rightarrow$  Small scale fading

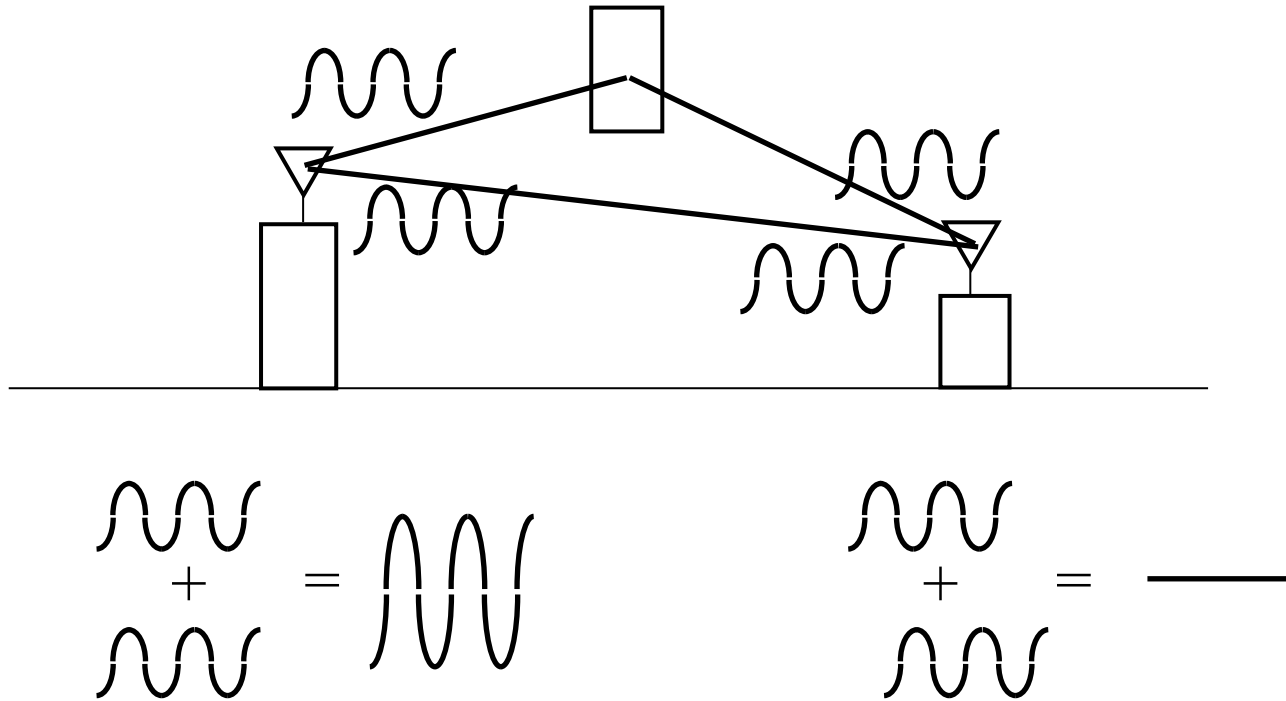

## Student Questions

# Shadowing

- Shadowing gives rise to large scale fading

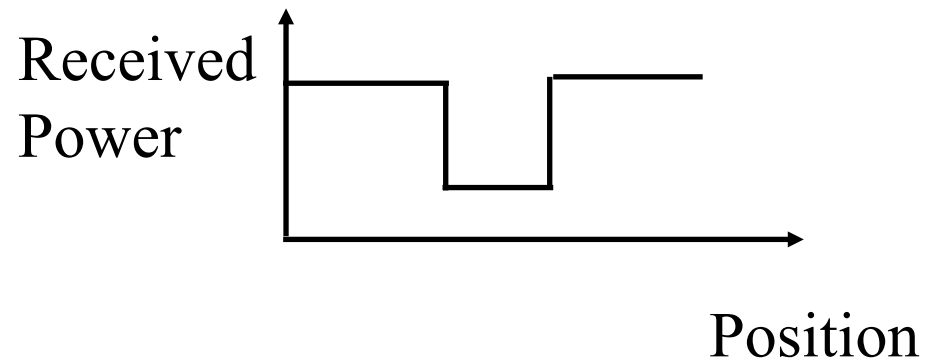
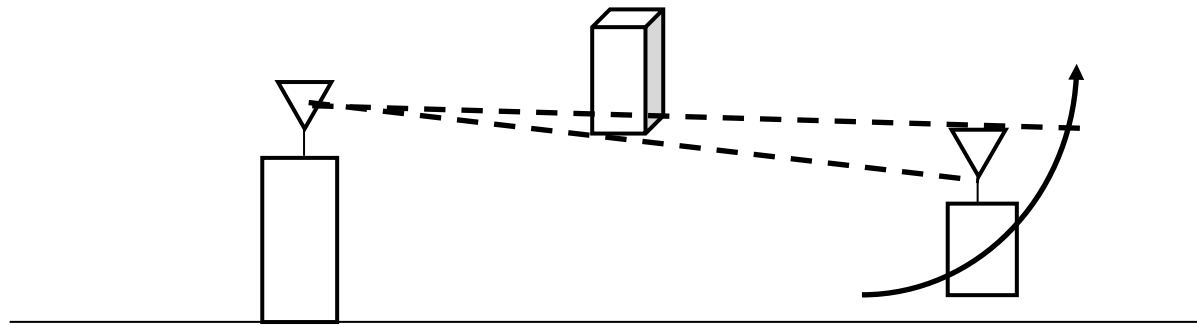

## Student Questions

# Total Path Loss

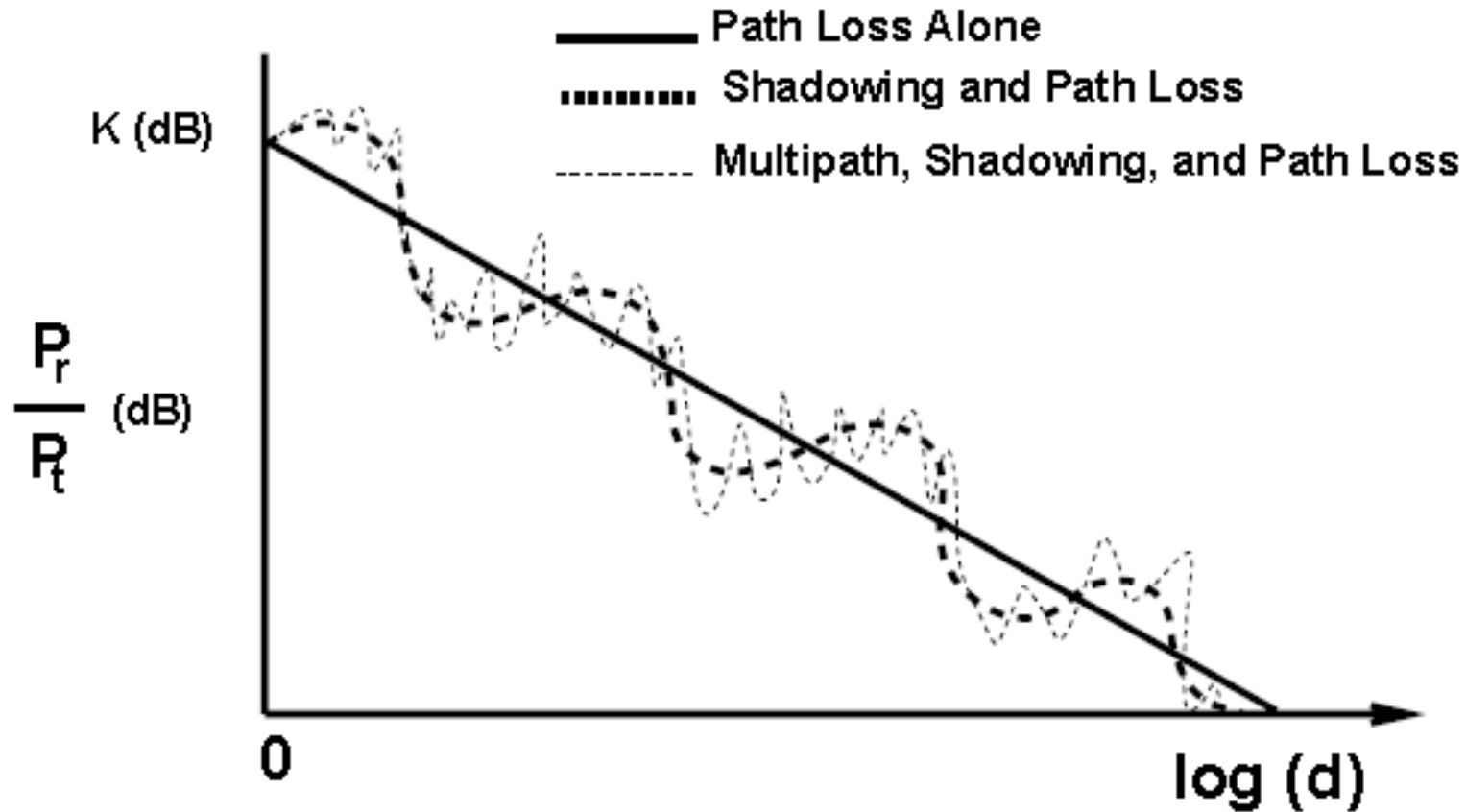

## Student Questions

# Fresnel Zones

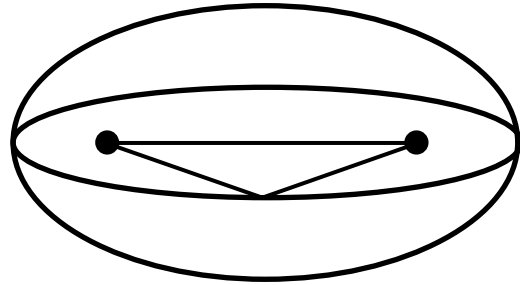

- ❑ Draw an ellipsoid with BS and MS as Foci
- ❑ All points on ellipsoid have the same BS-MS run length
- ❑ Fresnel ellipsoids = Ellipsoids for which run length =  $\text{LoS} + i\lambda/2$
- ❑ At the Fresnel ellipsoids results in a phase shift of  $i\pi$
- ❑ Radius of the  $i^{\text{th}}$  ellipsoid at distance  $d_T$  from the transmitter and  $d_R$  from the receiver is
$$\sqrt{\frac{i\lambda d_T d_R}{d_T + d_R}}$$
- ❑ Free space ( $d^2$ ) law is followed up to the distance at which the first Fresnel Ellipsoid touches the ground

## Student Questions



# Multi-Antenna Systems

- ❑ Receiver Diversity
- ❑ Transmitter Diversity
- ❑ Beam forming
- ❑ MIMO

## Student Questions

# Receiver Diversity

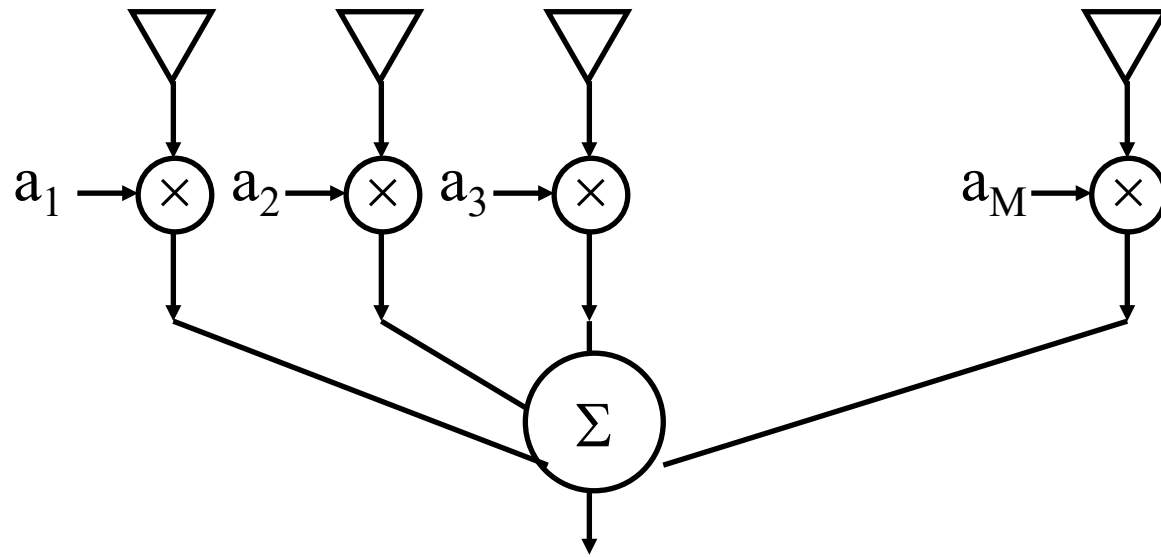

- ❑ User multiple receive antenna
- ❑ Selection combining: Select antenna with highest SNR
- ❑ Threshold combining: Select the first antenna with SNR above a threshold
- ❑ Maximal Ratio Combining: Phase is adjusted so that all signals have the same phase. Then weighted sum is used to maximize SNR

## Student Questions

# Transmitter Diversity

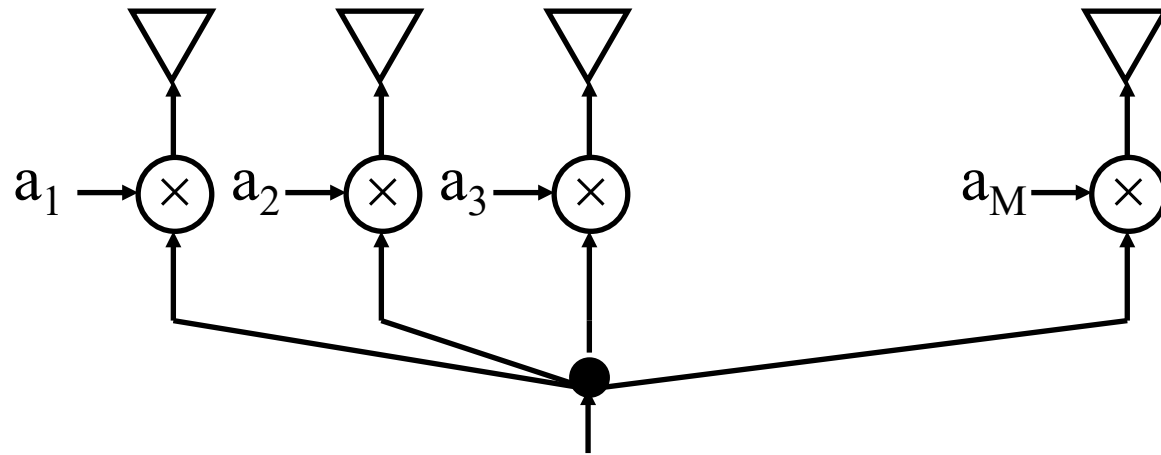

- ❑ Use multiple antennas to transmit the signal ample space, power, and processing capacity at the transmitter (but not at the receiver).
- ❑ If the channel is known, phase each component and weight it before transmission so that they arrive in phase at the receiver and maximize SNR
- ❑ If the channel is not known, use space time block codes

## Student Questions

# Beam forming

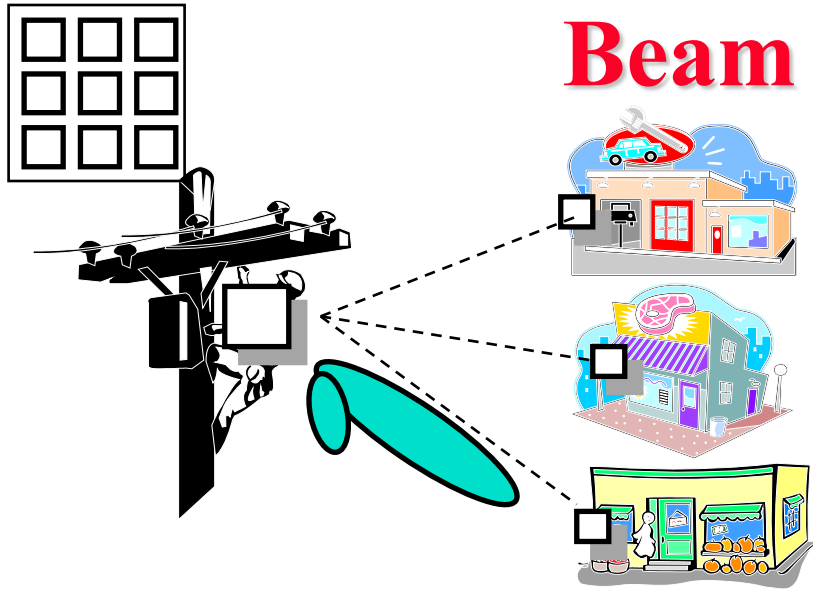

## Student Questions

- ❑ Phased Antenna Arrays:  
Receive the same signal using multiple antennas
- ❑ By phase-shifting various received signals and then summing  $\Rightarrow$  Focus on a narrow directional beam
- ❑ Digital Signal Processing (DSP) is used for signal processing  $\Rightarrow$  Self-aligning

# MIMO



- ❑ Multiple Input Multiple Output
- ❑ RF chain for each antenna  
⇒ Simultaneous reception or transmission of multiple streams

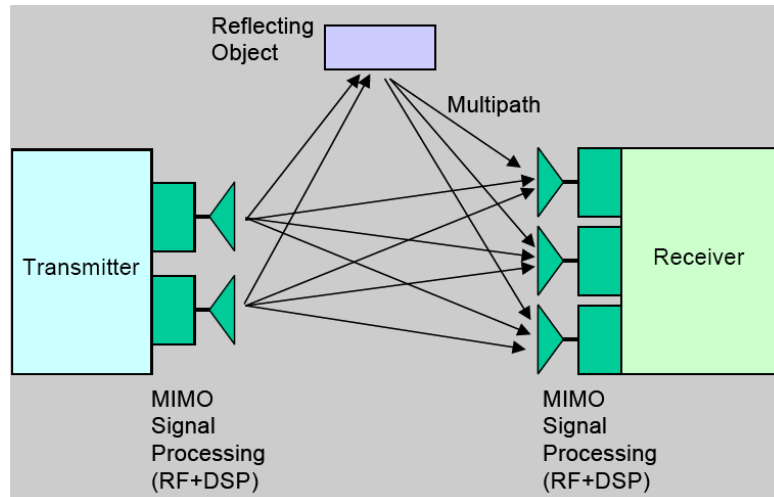

## Student Questions

802.16e at 2.5 GHz, 10 MHz TDD, D:U=2:1

T:R	1x1	1x2	2x2	2x4	4x2	4x4
b/Hz	1.2	1.8	2.8	4.4	3.7	5.1

# Multiple Access Methods

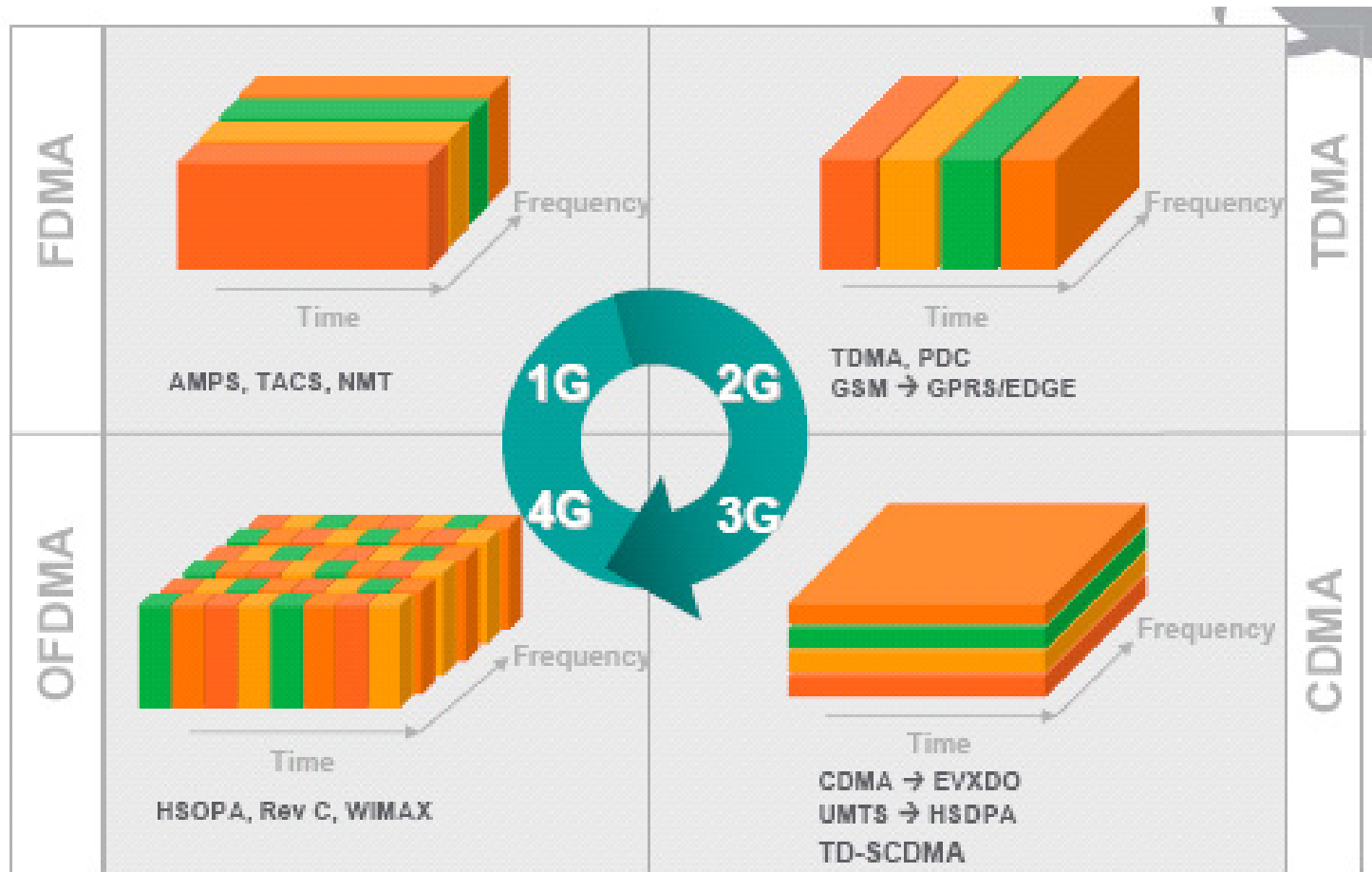

**Student Questions**

Source: Nortel

# OFDM

- ❑ Orthogonal Frequency Division Multiplexing
- ❑ Ten 100 kHz channels are better than one 1 MHz Channel  
⇒ Multi-carrier modulation

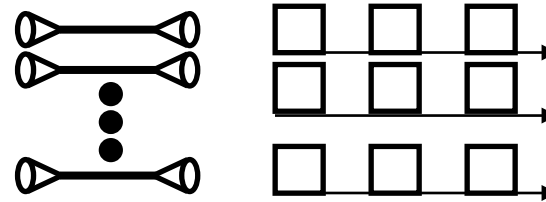
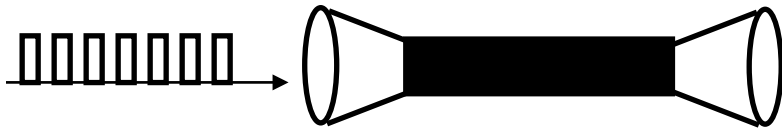

- ❑ Frequency band is divided into 256 or more sub-bands.  
Orthogonal ⇒ Peak of one at null of others
- ❑ Each carrier is modulated with a BPSK, QPSK, 16-QAM, 64-QAM etc depending on the noise (Frequency selective fading)
- ❑ Used in 802.11a/g, 802.16,  
Digital Video Broadcast handheld (DVB-H) and
- ❑ Easy to implement using FFT/IFFT

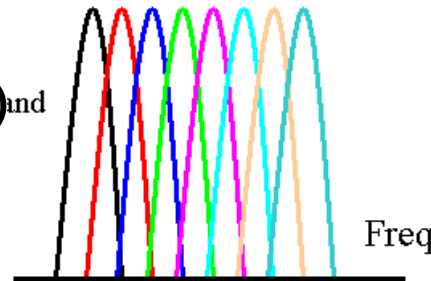
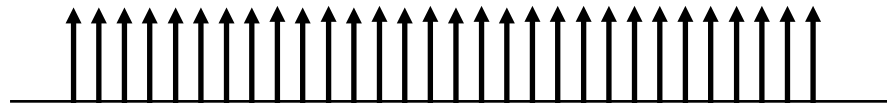

## Student Questions

# Advantages of OFDM

- ❑ Easy to implement using FFT/IFFT.  
FFT/IFFT are implemented only as powers of 2 (256, 1024, ...)
- ❑ Computational complexity =  $O(B \log BT)$  compared to previous  $O(B^2T)$  for Equalization. Here B is the bandwidth and T is the delay spread.
- ❑ Graceful degradation if excess delay
- ❑ Robustness against frequency selective burst errors
- ❑ Allows adaptive modulation and coding of subcarriers
- ❑ Robust against narrowband interference (affecting only some subcarriers)
- ❑ Allows **pilot** subcarriers for channel estimation

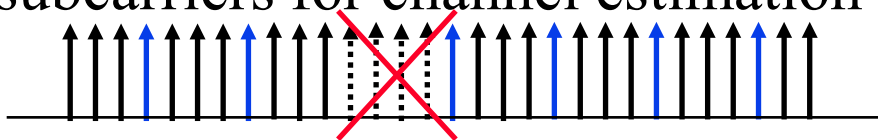

## Student Questions



# OFDM: Design considerations

- ❑ Large number of carriers  $\Rightarrow$  Smaller data rate per carrier  
 $\Rightarrow$  Larger symbol duration  $\Rightarrow$  Less inter-symbol interference
- ❑ Reduced subcarrier spacing  $\Rightarrow$  Increased inter-carrier interference due to Doppler spread in mobile applications
- ❑ Easily implemented as Inverse Discrete Fourier Transform (IDFT) of data symbol block
- ❑ Fast Fourier Transform (FFT) is a computationally efficient way of computing DFT

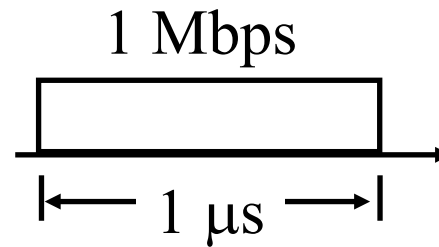
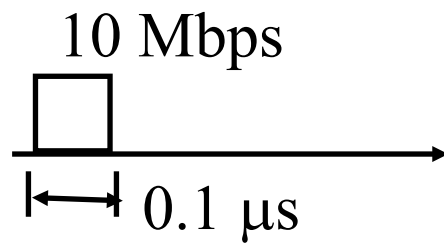

## Student Questions

# OFDMA

- ❑ Orthogonal Frequency Division Multiple Access
- ❑ Each user has a subset of subcarriers for a few slots
- ❑ OFDM systems use TDMA
- ❑ OFDMA allows Time+Freq DMA  $\Rightarrow$  2D Scheduling

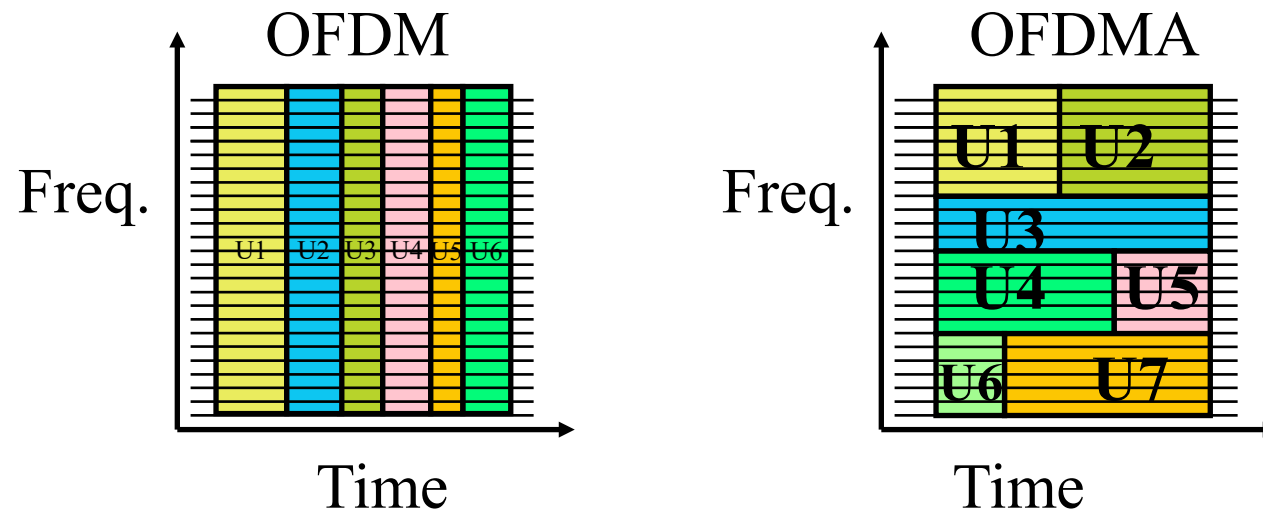

## Student Questions

# Scalable OFDMA (SOFDMA)

- ❑ OFDM symbol duration =  $f(\text{subcarrier spacing})$
- ❑ Subcarrier spacing = Frequency bandwidth/Number of subcarriers
- ❑ Frequency bandwidth=1.25 MHz, 3.5 MHz, 5 MHz, 10 MHz, 20 MHz, etc.
- ❑ Symbol duration affects higher layer operation
  - ⇒ Keep symbol duration constant at 102.9  $\mu\text{s}$
  - ⇒ Keep subcarrier spacing 10.94 kHz
  - ⇒ Number of subcarriers  $\propto$  Frequency bandwidth

This is known as scalable OFDMA

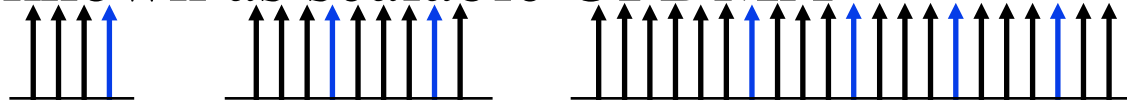

## Student Questions

# Effect of Frequency

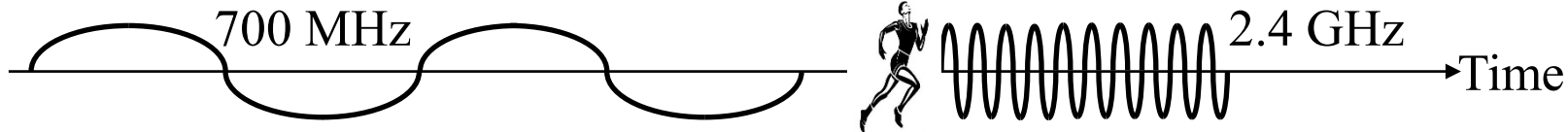

- ❑ Higher Frequencies have higher attenuation, e.g., 18 GHz has 20 dB/m more than 1.8 GHz
- ❑ Higher frequencies need smaller antenna  
Antenna  $\geq$  Wavelength/2, 800 MHz  $\Rightarrow$  6"
- ❑ Higher frequencies are affected more by weather  
Higher than 10 GHz affected by rainfall  
60 GHz affected by absorption of oxygen molecules
- ❑ Higher frequencies have more bandwidth and higher data rate
- ❑ Higher frequencies allow more frequency reuse  
They attenuate close to cell boundaries. Low frequencies propagate far.

## Student Questions

# Effect of Frequency (Cont)

- ❑ Lower frequencies have longer reach
  - ⇒ Longer Cell Radius
  - ⇒ Good for rural areas
  - ⇒ Smaller number of towers
  - ⇒ Longer battery life
- ❑ Lower frequencies require larger antenna and antenna spacing
  - ⇒ MIMO difficult particularly on mobile devices
- ❑ Lower frequencies ⇒ Smaller channel width
  - ⇒ Need aggressive MCS, e.g., 256-QAM
- ❑ Doppler shift =  $vf/c = \text{Velocity} \times \text{Frequency} / (\text{speed of light})$ 
  - ⇒ Lower Doppler spread at lower frequencies
- ❑ Mobility ⇒ Below 10 GHz

## Student Questions

# Summary

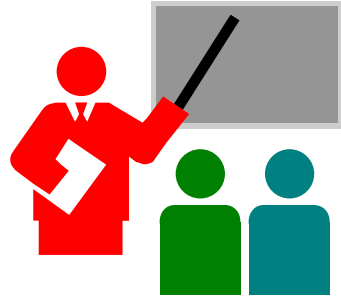

1. Path loss increase at a power of 2 to 5.5 with distance.
2. Fading = Changes in power changes in position
3. Fresnel zones = Ellipsoid with distance of  $LoS + i\lambda/2$   
Any obstruction of the first zone will increase path loss
4. Multiple Antennas: Receive diversity, transmit diversity, Smart Antenna, MIMO
5. OFDM splits a band in to many orthogonal subcarriers.  
OFDMA = FDMA + TDMA

## Student Questions

## Homework 4

- A. Determine the mean received power at a SS. The channel between a base station at 14 m and the subscriber stations at 4m at a distance of 500m. The Transmitter and Receiver antenna gains are 10dB and 5 dB respectively. Use a power exponent of 4. Transmitted power is 30 dBm. Do All calculations using dB.
- B. With a subcarrier spacing of 10 kHz, how many subcarriers will be used in a system with 8 MHz channel bandwidth and what size FFT will be used?
- C. In a scalable OFDMA system, the number of carriers for 10 MHz channel is 1024. How many carriers will be used if the channel was 1.25 MHz, 5 MHz, or 8.75 MHz.

### Student Questions

# Reading List

- ❑ Jim Geier, "Radio Wave Fundamentals," Chapter 2 in his book "Designing and Deploying 802.11 Wireless Networks: A Practical Guide to Implementing 802.11n and 802.11ac Wireless Networks, Second Edition," Cisco Press, May 2015, 600 pp., ISBN:1-58714-430-1 (Safari Book), Chapter 2.
- ❑ Raj Jain, "Channel Models: A Tutorial," WiMAX Forum AATG, February 2007, first 7 of 21 pages, [http://www.cse.wustl.edu/~jain/wimax/channel\\_model\\_tutorial.htm](http://www.cse.wustl.edu/~jain/wimax/channel_model_tutorial.htm)
- ❑ Jim Geier, "Wireless Networks first-step," Cisco Press, August 2004, 264 pp., ISBN:1-58720-111-9 (Safari Book), Chapter 3.
- ❑ Steve Rackley, "Wireless Networking Technology," Newnes, March 2007, 416 pp., ISBN:0-7506-6788-5 (Safari Book), Chapter 4.
- ❑ Stephan Jones; Ronald J. Kovac; Frank M. Groom, "Introduction to Communications Technologies, 3rd Edition," CRC Press, July 2015, 364 pp., ISBN:978-1-4987-0295-9 (Safari Book), Chapters 3 and 4.

## Student Questions



# Wikipedia Links

- ❑ [https://en.wikipedia.org/wiki/Omnidirectional\\_antenna](https://en.wikipedia.org/wiki/Omnidirectional_antenna)
- ❑ [https://en.wikipedia.org/wiki/Antenna\\_gain](https://en.wikipedia.org/wiki/Antenna_gain)
- ❑ [https://en.wikipedia.org/wiki/Equivalent\\_isotropically\\_radiated\\_power](https://en.wikipedia.org/wiki/Equivalent_isotropically_radiated_power)
- ❑ [https://en.wikipedia.org/wiki/High-gain\\_antenna](https://en.wikipedia.org/wiki/High-gain_antenna)
- ❑ [https://en.wikipedia.org/wiki/Signal\\_reflection](https://en.wikipedia.org/wiki/Signal_reflection)
- ❑ <https://en.wikipedia.org/wiki/Scattering>
- ❑ [https://en.wikipedia.org/wiki/Path\\_loss](https://en.wikipedia.org/wiki/Path_loss)
- ❑ [https://en.wikipedia.org/wiki/Free-space\\_path\\_loss](https://en.wikipedia.org/wiki/Free-space_path_loss)
- ❑ [https://en.wikipedia.org/wiki/Log-distance\\_path\\_loss\\_model](https://en.wikipedia.org/wiki/Log-distance_path_loss_model)
- ❑ [https://en.wikipedia.org/wiki/Multipath\\_propagation](https://en.wikipedia.org/wiki/Multipath_propagation)
- ❑ [https://en.wikipedia.org/wiki/Multipath\\_interference](https://en.wikipedia.org/wiki/Multipath_interference)
- ❑ [https://en.wikipedia.org/wiki/Intersymbol\\_interference](https://en.wikipedia.org/wiki/Intersymbol_interference)
- ❑ <https://en.wikipedia.org/wiki/Fading>
- ❑ [https://en.wikipedia.org/wiki/Shadow\\_fading](https://en.wikipedia.org/wiki/Shadow_fading)
- ❑ [https://en.wikipedia.org/wiki/Fresnel\\_zone](https://en.wikipedia.org/wiki/Fresnel_zone)

## Student Questions

# Wikipedia Links (Cont)

- ❑ [https://en.wikipedia.org/wiki/Antenna\\_diversity](https://en.wikipedia.org/wiki/Antenna_diversity)
- ❑ <https://en.wikipedia.org/wiki/Beamforming>
- ❑ [https://en.wikipedia.org/wiki/Antenna\\_array\\_\(electromagnetic\)](https://en.wikipedia.org/wiki/Antenna_array_(electromagnetic))
- ❑ [https://en.wikipedia.org/wiki/Phased\\_array](https://en.wikipedia.org/wiki/Phased_array)
- ❑ [https://en.wikipedia.org/wiki/Smart\\_antenna](https://en.wikipedia.org/wiki/Smart_antenna)
- ❑ [https://en.wikipedia.org/wiki/Multiple-input\\_multiple-output\\_communications](https://en.wikipedia.org/wiki/Multiple-input_multiple-output_communications)
- ❑ [https://en.wikipedia.org/wiki/Diversity\\_combining](https://en.wikipedia.org/wiki/Diversity_combining)
- ❑ [https://en.wikipedia.org/wiki/Maximal-ratio\\_combining](https://en.wikipedia.org/wiki/Maximal-ratio_combining)
- ❑ [https://en.wikipedia.org/wiki/Orthogonal\\_frequency-division\\_multiplexing](https://en.wikipedia.org/wiki/Orthogonal_frequency-division_multiplexing)
- ❑ [https://en.wikipedia.org/wiki/Orthogonal\\_frequency-division\\_multiple\\_access](https://en.wikipedia.org/wiki/Orthogonal_frequency-division_multiple_access)

## Student Questions

# Acronyms

- ❑ BPSK Binary Phase-Shift Keying
- ❑ BS Base Station
- ❑ dB DeciBels
- ❑ dBi DeciBels Intrinsic
- ❑ dBm DeciBels milliwatt
- ❑ DFT Discrete Fourier Transform
- ❑ DMA Direct Memory Access
- ❑ DSP Digital Signal Processing
- ❑ DVB-H Digital Video Broadcast handheld
- ❑ FDMA Frequency Division Multiple Access
- ❑ FFT Fast Fourier Transform
- ❑ IDFT Inverse Discrete Fourier Transform
- ❑ IFFT Inverse Fast Fourier Transform
- ❑ ISI Inter-symbol interference
- ❑ kHz Kilo Hertz
- ❑ LoS Line of Sight

## Student Questions

# Acronyms (Cont)

- ❑ MHz Mega Hertz
- ❑ MIMO Multiple Input Multiple Output
- ❑ MS Mobile Station
- ❑ OFDM Orthogonal Frequency Division Multiplexing
- ❑ OFDMA Orthogonal Frequency Division Multiple Access
- ❑ QAM Quadrature Amplitude Modulation
- ❑ QPSK Quadrature Phase-Shift Keying
- ❑ RF Radio Frequency
- ❑ SNR Signal to Noise Ratio
- ❑ SS Subscriber Station
- ❑ TDMA Time Division Multiple Access

## Student Questions

**Scan This to Download These Slides**



Raj Jain

<http://rajjain.com>

[http://www.cse.wustl.edu/~jain/cse574-22/j\\_04wsp.htm](http://www.cse.wustl.edu/~jain/cse574-22/j_04wsp.htm)

**Student Questions**

# Related Modules



CSE567M: Computer Systems Analysis (Spring 2013),  
[https://www.youtube.com/playlist?list=PLjGG94etKypJEKjNAa1n\\_1X0bWWNyZcof](https://www.youtube.com/playlist?list=PLjGG94etKypJEKjNAa1n_1X0bWWNyZcof)

CSE473S: Introduction to Computer Networks (Fall 2011),  
[https://www.youtube.com/playlist?list=PLjGG94etKypJWOSPMh8Azcg5e\\_10TiDw](https://www.youtube.com/playlist?list=PLjGG94etKypJWOSPMh8Azcg5e_10TiDw)



Recent Advances in Networking (Spring 2013),  
<https://www.youtube.com/playlist?list=PLjGG94etKypLHyBN8mOgwJLHD2FFIMGq5>

CSE571S: Network Security (Fall 2011),  
<https://www.youtube.com/playlist?list=PLjGG94etKypKvzfVtutHcPFJXumyyg93u>



Video Podcasts of Prof. Raj Jain's Lectures,  
<https://www.youtube.com/channel/UCN4-5wzNP9-ruOzQMs-8NUw>

## Student Questions