

Wireless Datalink for Unmanned Aircraft Systems: Requirements, Challenges and Design Ideas

Raj Jainⁱ

Washington University in Saint Louis

and

Fred L. Templinⁱⁱ

The Boeing Company

The key challenges in the design of datalinks for UAS systems compared to other wireless links is the long range of distances and speeds that need to be covered. The amount of spectrum available in the L-Band is not sufficient to support video applications common in UASs and so dual-band designs using both L-Band and C-Band are being considered. For L-Band, two projects funded by EUROCONTROL L-Band Digital Aeronautical Communications Systems 1 and 2 (L-DACS1 and L-DACS2) are often mentioned for use in UAS also. We briefly discuss issues with their use for UAS. Then we discuss several issues in UAS datalink design including availability, networking, preemption, and chaining. We also propose ways to mitigate interference with other systems in the L-Band.

Nomenclature

c	=	Velocity of light
d	=	Distance
f	=	Frequency
G_T	=	Gain of the transmitting antenna
G_R	=	Gain of the receiving antenna
λ	=	Wavelength
P_T	=	Transmitted power
P_R	=	Received power
T_c	=	Transaction completion Time
v	=	Velocity of the aircraft

I. Introduction

New datalinks need to be developed for Unmanned Aircraft Systems (UAS) and for commercial manned particularly because they will share the same non-segregated air space and would need to be aware of each other's presence.

The key challenges in the design of aeronautical communication systems are the large distances that they need to cover and the high-speed of aircrafts. These along with the limited availability of radio frequency spectrum affect the performance of the datalink.

Over the past several years, EUROCONTROL has funded two projects for developing new datalinks for aeronautical communications.¹⁻³ These projects resulted in two proposals named L-DACS1 and L-DACS2 are often mentioned in UAS discussions.⁴⁻⁹ It is, therefore, important to analyze their performance. In addition, UAS communication has additional requirements on availability, networking, and traffic management.

This paper is organized as follows. In Section II, we present the challenges faced in designing aeronautical datalinks. Section III discusses suitability of L-DACS1 and L-DACS2 for the next generation of aeronautical

ⁱ Professor of Computer Science and Engineering, Washington University in Saint Louis, Campus Box 1045, St. Louis, MO 63130, jain@acm.org, AIAA Member

ⁱⁱ Senior Research Engineer, Boeing Research & Technology, PO Box 3707 MC 7L-49, Seattle, WA 98124

communications. In Section IV, we present some additional requirements for UAS datalink design. Section V presents some strategies for mitigation of interference in L-Band. Finally, we summarize our conclusions in Section VI.

II. AERONAUTICAL DATALINKS: CHALLENGES

Designing aeronautical wireless datalinks is much more challenging than other wireless links. The key challenges are: Long Distance, High-Speed, and Spectrum. In this section we review these challenges. Much of this discussion applies to both UAS and commercial manned civil aviation.

A. Long Distances

The main challenge for aeronautical datalinks is the long distances covered by these datalinks. The most common wireless link used today is IEEE 802.11 links also called WiFi. It covers only 100 meters. IEEE has also developed IEEE 802.16 wireless networks for metropolitan area coverage. This link popularly known as WiMAX uses cell sizes of 1 km in urban areas and 3 km in suburban areas. These sizes also apply to 3GPP LTE.¹⁸ For longer distances, the signal strength decreases rapidly by 2nd to 4th power of the distance. Compare these to aeronautical datalinks that have to cover up to 200 nautical miles, i.e., 360 km. This is two orders of magnitude larger than WiMAX and also cellular networks. This distance results in significant power attenuation in the path and results in a very low spectral efficiency. The efficiency is measured by bits per second per Hertz (bps/Hz). WiMAX networks have an efficiency of 3-5 bps/Hz at 0.9 km.¹⁰ Achieving even 2 bps/Hz is a challenge on aeronautical datalinks.

The long distance also results in large round-trip delays that require large guard times. It takes approximately 1.2 ms for light to travel 360 km one-way. Compare this to just 17 μ s required for 5 km in WiMAX networks. The increased guard times further decrease the spectral efficiency.

B. High Speeds

The second challenge is the speed of mobility. WiFi supports very limited mobility. Since the coverage is only a few hundred meters, a car travelling at 100 km/h will need to change base stations every 7.2 seconds. WiMAX design is optimized for 0-10 km/h and supports operation up to 120 km/h.¹¹ RTCA SC223 committee on Airport Surface Wireless Communications¹⁹ is developing "aeroMACS" datalink standard which is based on WiMAX technology and is designed for takeoff and landing applications. The takeoff and landing speeds are in the range of 100-170 nautical miles/h.²⁰ Aeronautical datalinks for other phases of flight have to be designed for planes traveling at 600 nautical miles/h or 1080 km/h. Again these high speeds result in a high Doppler spread and affect the spectral efficiency.

C. Frequency Spectrum

Table 1 lists some of the common frequency bands used in wireless communications. Aeronautical communications systems have traditionally used high-frequency (HF) and very high frequency (VHF) bands as well as higher frequency bands used for satellite communications (SATCOM). However, SATCOM systems are not always available during all phases of flight and the HF and VHF bands are getting very congested. Given the growth in the air traffic, it has therefore become necessary to identify new spectrum for air-to-ground data links. The L-Band, which is already used for several other aeronautical communication functions and has recently become available for Aeronautical Mobile Route Service (AMRS), has been tentative designated as the next desired band.

Table 1: Frequency Bands

Band	Frequency
HF	3-30 MHz
VHF	30-300 MHz
UHF	300-1000 MHz
L	1-2GHz (General) 950-1450 MHz (IEEE)
S	2-4 GHz
C	4-8 GHz
X	8-12 GHz
Ku	12-18 GHz
K	18-26.5 GHz
Ka	26.5-40 GHz

D. Impact of Moving from VHF to L-Band

It is helpful to first understand the effect of frequency on the datalink design. Lower frequency bands are generally preferred. However, they are getting crowded and so the general trend is to move up in frequency. The crowding in HF band made aeronautical datalinks to move to VHF band and now crowding in VHF band is making us move to L-band. These higher frequency bands are wider and, therefore, can allow wider channels required for higher data rates needed today.

The most basic relationship in wireless link is shown in the equation below. This equation gives the power received (P_R) for a given power transmitted (P_T) at a given wavelength (λ):

$$P_R = P_T G_T G_R \left(\frac{\lambda}{4\pi d} \right)^2$$

Here, d is the distance, G_T is the gain of the transmitting antenna and G_R is the gain of the receiving antenna. The wavelength (λ) is given by:

$$\lambda = \frac{c}{f}$$

Where c is the speed of light and f is the frequency. These equations indicated that the path loss is proportional to the square of frequency and distance product:

$$\text{Path Loss} \propto (fd)^2$$

That is, if we go up 10 times in frequency, the loss will go up by a factor of 100 or we need to decrease the distance by a factor of 10. Note that the Equation 1 is a theoretical approximation. In practice, the distance exponent is more than 2 (between 2 and 5). In fact, a commonly used distance exponent is 4. One consequence of the above is that the power required to cover the same distance at higher frequency is much more than those at lower frequencies. Stated differently, given the similar amount of power, the signal level is significantly reduced and so the spectral efficiency (bps/Hz) has to be reduced to allow the lower signal-to-noise ratio (SNR). Since higher frequencies do not travel very far, the cell sizes are smaller and so there are more opportunities for frequency reuse.

The second effect of higher frequency is due to Doppler spread.

$$\text{Doppler spread} \propto \frac{v}{\lambda}$$

Here v is the velocity in m/s and λ is the wavelength in m. Again, lower frequencies have longer wavelength and result in smaller Doppler spread. They are better suited for high-speed mobility applications.

The antenna size required is proportional to wavelength. Therefore, higher frequencies need smaller antenna and are preferable for that reason in applications where the mobile station is a small handheld device as is the case in cellular applications.

Another consideration in selecting a frequency band is the effect of weather. Some of frequencies, e.g., 28 GHz band, are affected by rain fall.

III. Suitability of L-DACS1 and L-DACS2 for UAS

Two groups both funded by EUROCONTROL - the European organization for the Safety of Air Navigation - have developed two separate proposals: L-Band Digital Aeronautical Communication Systems of Type 1 (L-DACS1) and Type 2 (L-DACS2) for commercial aviation. Although, they have not been formally approved for standardization, they are frequently mentioned in aeronautical communication documents as potential candidates for adoption. In this section, we provide a very brief overview of these proposals.

L-DACS1 uses multi-carrier modulation similar to WiMAX. Its physical layer allocation maps and allocation units (tiles and chunks) are similar to those in WiMAX.

L-DACS2 is based on GSM. It uses GSM physical layer. It uses GMSK (Gaussian Minimum Shift Keying) modulation used in the original GSM. Later enhancements to GSM, such as GPRS and EDGE use more aggressive coding but they are not part of L-DACS2. GSM works at 900 MHz, 1800 MHz, and 1900 MHz bands. L-DACS2 is designed to use a single 200 kHz channel in 960-975 MHz band. This is very close to the GSM900 band and so most of the GSM design parameters can be reused in L-DACS2. This design also allows reuse of the volume GSM components resulting in low-cost implementations.

We have surveyed the key features of the two L-band digital aeronautical communication systems.¹² We are not associated with either of the two design teams and so this is one of the few independent comparisons of the two systems. Our conclusions in that paper are as follows:

1. L-DACS1 with OFDM is more scalable than L-DACS2 with single carrier modulation. Although as specified, both L-DACS1 and L-DACS2 use fixed spectral width, L-DACS1 can be easily scaled up to fit any available width.
2. L-DACS1 also has better spectral efficiency because it can use adaptive modulation and coding (QPSK through 64 QAM) depending upon the noise and interference pattern. Single carrier modulation and GMSK used by L-DACS2 do not easily adopt to dynamic noise conditions.
3. Multi-carrier design of L-DACS1 is also more flexible in terms of spectrum placement. With proper profile (parameter set), it can use any available white space in the L-band. Single-carrier radios of L-DACS2 would find it more difficult to adapt to different frequency possibilities.
4. Multi-carrier design of L-DACS1 is also suitable for interference avoidance and co-existence than L-DACS2.
5. The TDD design of L-DACS2 allows for asymmetric data traffic. The FDD design of L-DACS1 is suitable for symmetric voice traffic but less suitable for data. Also requiring a frequency pair separated by 63 MHz may make it harder to find suitable frequencies. The asymmetry of the control data traffic needs to be studied. Multi-carrier aggregation introduced in IEEE 802.16m can be used in L-DACS1 to overcome the problem of availability of adjacent spectrum availability and use TDD.
6. The cyclic prefix and subcarrier spacing of L-DACS1 need to be analyzed to ensure that they will cover the distance and speeds required for ENR region operation.
7. The co-existence strategies will need to be incorporated in the L-DACS control design so that aircrafts can inform the ground station schedulers about their desirable and undesirable time and frequency opportunities.
8. GSM900 stations may cause significant interference with the L-DACS systems. Again L-DACS2 is more susceptible to such interference because its proposed spectrum is very close to that of GSM900. The effect of multiple GSM900 transmitters near the L-DACS ground stations needs to be analyzed.

Other groups have also reached similar conclusions and a proposal that takes the best features of these two proposals is being discussed in SC203 Unmanned Aircraft Systems committee of RTCA.¹³ This proposal uses OFDMA as in L-DACS1 and combines it with TDD as in L-DACS2. This is a dual-band design using both L and C bands. The purpose of this design is to help estimate the size of spectrum required.

IV. Issues in UAS Datalink Design

A. High-Availability:

One of the most critical requirements for UAS is the ability to “Sense and Avoid.” That is, if an object is sensed nearby, the remote pilot should be able to avoid it. The normal definition of availability – the ratio of mean uptime to total time is not meaningful in such situations. For example, consider two systems – one with very small uptimes and small downtimes and another with large uptimes and large downtimes. Both these systems may have the same availability but the system with small uptime may not be very useful since it fails so frequently and may not be able to complete any transactions.

This issue was discussed in the SC203 committee and an alternative metrics called “Continuity” was proposed which is defined as follows:

$$Continuity = \frac{\sum_i (Uptime_i | Uptime_i > Tc)}{TotalTime}$$

Here, T_c is the transaction completion time. This definition also ignores the large downtimes that can be deadly in the case of UAS. Also, this expression is not the probability of transaction completion either. Successful transaction completion requires that the transaction begin at least T_c units of time before the end of uptime and, therefore,

$$P(TransactionCompletion) = \frac{\sum_i (Uptime_i - Tc | Uptime_i > Tc)}{TotalTime}$$

The problem with this probability is that it assumes that the risk is proportional to the downtime. This is true in many other applications. However, for sense and avoid applications, the risk increases significantly if the downtime exceeds a certain threshold.

For sense and avoid application, large downtimes as well as small uptimes are bad. Therefore, it is important to limit the probabilities of large downtime and small uptimes (See Figure 1).

This leads to the conclusion that the best metric to measure the availability for UAS sense and avoid applications is some percentile, say, 99.999th percentile of the downtime and 0.001th percentile of the uptime. For a good system, the 99.999th percentile of downtime should be low and the 0.001th percentile of the uptime should be high. Given these two numbers it is easy to compute the risk.

B. High-Availability:

It is normally assumed that the UAS is communicating with a wireless ground stations that is connected to the human controller via a ground network. In this case, the ground station is part of a nationwide system of control stations that coordinate with each other. In this case, there is a possibility of a smooth handover of UAS from one ground station to next. This is called “Networked” Controller scenario. An alternative scenario is that of a controller directly communicating with the UAS via a wireless link. The datalink needs to support both networked and non-networked scenarios.

This would generally be the case for small UASs in remote areas particularly in military applications. This is the non-networked controller scenario. The datalink needs to support both networked and non-networked scenarios.

C. Overload Control and Preemption:

Regardless of what design is used, there would be situations when the number of UASs communicating with the ground stations exceeds the nominal capacity. In these cases, it is important the users with more critical services (such as sense and avoid) be given priority over those with less critical services (video surveillance). So a priority system is required that will allow lower priority services to be delayed or preempted to make way for high-priority services.

D. Chaining:

Chaining, also known as multi-hopping, refers to the case of an UAS helping another UAS to reach the ground station. The chain could consist of more than two UASs. This application is important for areas where there is no ground infrastructure such as in military environments.

E. Compatibility and Co-Existence with Manned Aircraft

It is important that the UAS datalink architecture be compatible with that used for manned aircrafts since both of them will be sharing the same frequency bands and the same airspace. The traffic requirements envisioned for future manned aircraft communications are currently significantly higher than those for unmanned aircrafts.

The requirements for manned aircrafts are specified in COCR (Communications Operating Concept and Requirements) V2¹⁴ which specifies two phases. The first phase begins now and the second phase begins in 2020 after which both phases will continue till 2030. COCR specifies a peak instantaneous aircraft counts (PIACs) in the range of 200 to 300 aircrafts for high-density airports. The UAS requirements are only in the range of 20 aircraft per ground station. So it would be difficult to use the same design for both manned and unmanned systems. This would introduce a compatibility issue where the two systems will not be able to communicate with each other or the same ground stations.

V. Interference Mitigation and Coexistence Strategies

One problem with L-Band is that the band is already used by several aeronautical applications (See Figure 2). These applications will interfere with each other.

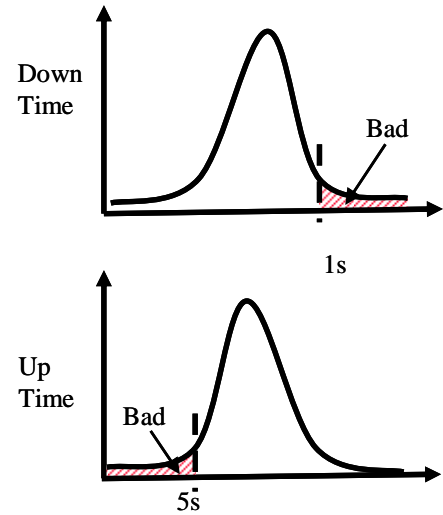

Figure 1: Percentiles of downtime and uptime are better metric for sense and avoid applications than availability.

Multiple wireless technologies sharing spectrum is very common in unlicensed band. For example, Bluetooth and WiFi share the 2.4 GHz band. Most laptop computers today are equipped with both Bluetooth and WiFi. The coexistence strategies used by them¹⁵ can be used for UAS as well. In this section, we propose such strategies.

F. Collaborative Co-Existence of DME and L-DACS

Aircrafts will have both DME and L-DACS. As indicated earlier the two antennas will interfere significantly. Since both equipments are on the same aircraft, it is possible to design the two systems so that they collaborate in avoiding the mutual interference. One simple strategy is to divide the time so that when DME stations are transmitting or receiving, the L-DACS system is quiet and when L-DACS is transmitting or receiving DME is quiet.

These strategies assume that aircraft DME system can be redesigned to accommodate L-DACS technology and the aircrafts are refitted with this updated version of DME. This may or may not always be feasible. We do not assume any changes to ground DME systems. The aircraft would have a common controller for the two systems and would dynamically determine the time allocation between the two depending upon the traffic. The aircraft L-DACS system will inform the ground station of unavailable times so that it will schedule transmission and reception opportunities for that aircraft accordingly.

In case of L-DACS1, it is also possible to notch out (not use) the subcarriers that are affected by the interference. In this sense, L-DACS1 is more resistant to interference and thus more survivable even under interference conditions.

B. Non-Collaborative Coexistence Strategies

If the DME system cannot be modified, the L-DACS system will have to use non-collaborative strategies. This would require L-DACS system to measure the interference pattern (time and frequency) and adjust its transmission and reception accordingly.

The interference and noise can be distinguished by the bit error patterns. Interference results in bursty errors while noise results in random errors. FEC can take care of random errors but bursty errors require retransmissions. So FEC may not be used if there is excessive interference. The resulting extra bits can be used for retransmission.

The L-DACS1 system can keep track of subcarriers on which there is excessive interference and not use them. Again, we find that L-DACS1 system is more interference resistant and more survivable than L-DACS2 system.

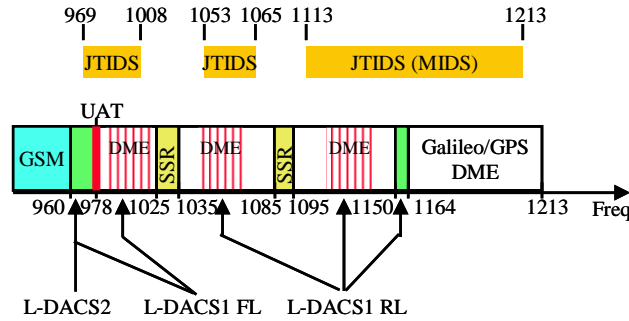

Figure 2: L-Band Spectrum Usage.

VI. Summary

In this paper, we have presented the challenges, requirements, and issues in designing datalinks for UAS. The two key challenges are: Long distances, high-speed. Covering these distances and aircraft speeds affects the efficiency of the datalinks. Significant changes to carrier spacing in multi-carrier modulations, e.g., OFDMA, is required to cover these speeds.

We also discussed the suitability of L-DACS1 and L-DACS2 proposals, which are commonly mentioned as candidates for the next generation aeronautical communications. Our conclusion is that a design with multi-carrier modulation and time-division duplexing would be more suitable than these two. SC203 committee on Unmanned Aircraft Systems is already working on such a design. Other requirements that the UAS datalink design needs to meet are:

1. High-availability: We need new metrics to allow risk assessment for sense and avoid applications.
2. Networked and Non-networked controllers: Both cases need to be covered.
3. Preemption: Need a multi-priority design to allow urgent communications to continue.
4. Chaining: To allow UASs to communicate to ground stations via other UASs
5. Compatibility with manned aircraft datalinks

Finally we showed how multiple aeronautical applications using the same L-Band can co-exist and avoid interference using collaborative and non-collaborative strategies.

References

- ¹EUROCONTROL L-band Communications Library,
http://www.eurocontrol.int/communications/public/standard_page/LBANDLIB.html
- ²EUROCONTROL, "L-DACS1 System Definition Proposal: Deliverable D2," Feb 13, 2009, 175 pp.,
http://www.eurocontrol.be/communications/gallery/content/public/documents/LDACS1_D2%20Del_Draft%20Spec%20Proposal_v01.pdf
- ³EUROCONTROL, "L-DACS2 System Definition Proposal: Deliverable D2," May 11, 2009, 121 pp.,
http://www.eurocontrol.int/communications/gallery/content/public/documents/LDCAS2_D2_Deliverable_v1.0.pdf
- ⁴ITU-R Working Party 5B, "Frequency band study to support control links for unmanned aircraft systems (UAS)," Preliminary draft of M.[UAS-BANDS ESISTING ALLOCATIONS], Document 5B/TEMP/267-E, 20 May 2010.
- ⁵ITU-R Working Party 5B, "AM(R)S sharing feasibility in the 960-1164 MHz Band," Preliminary draft of M.[AM(R)S_1GHZ_SHARING], Document 5B/TEMP/260, 29 June 2010.
- ⁶ITU-R Working Party 5B, "Characteristics of unmanned Aircraft Systems (UAS) and Spectrum Requirements to Support their Safe Operation in Non-Segregated Airspace," Preliminary Draft of M.[UAS-SPEC], Document 5B/TEMP/168, 3 December 2009.
- ⁷ITU-R Working Party 5B, "Frequency Band Study to Support Control Links for Unmanned Aircraft Systems (UAS)," Preliminary draft of M.[UAS-BANDS-NEW-ALLOC], Document 5B/TEMP/262-E, 20 May 2010.
- ⁸ITU-R Working Party 5B, "Characteristics and Performance Requirements for Unmanned Aircraft Control Links," Preliminary draft of M.[UAS-PERF-AND-REQ], Document 5B/TEMP/263-E, 20 May 2010.
- ⁹ITU-R Working Party 5B, "Characteristics and Spectrum Considerations for Sense and Avoid Systems use on Unmanned Aircraft Systems (UAS)," Preliminary draft of M.[UAS-SENSE AND AVOID], Document 5B/TEMP/264-E, 20 May 2010.
- ¹⁰R. Srinivasan (Ed), "IEEE 802.16m System Description Document (SDD)," IEEE 802.16 working group, Sep 3, 2009,
http://www.ieee802.org/16/tgm/docs/80216m-09_0034r1.zip
- ¹¹J. Pinola and K. Pentikousis, "Mobile WiMAX," The Internet Protocol Journal, Volume 11, No. 2,
http://www.cisco.com/web/about/ac123/ac147/archived_issues/ipj_11-2/112_wimax.html
- ¹²R. Jain, F. Templin, K. Yin, "Analysis of L-Band Digital Aeronautical Communication Systems: L-DACS1 and L-DACS2," 2011 IEEE Aerospace conference, Big Sky, MT, USA, March 5-11, 2011
- ¹³RTCA SC203 Committee on Unmanned Aircraft Systems, <http://www.rtca.org/comm/Committee.cfm?id=45>
- ¹⁴EUROCONTROL/FAA, "Communications Operating Concept and Requirements for the Future Radio System," COCR V2, 172 pp., http://www.eurocontrol.int/communications/gallery/content/public/documents/COCR_v2.pdf
- ¹⁵IEEE Std 802.15.2-2003, "IEEE Recommended Practice for Information technology— Telecommunications and information exchange between systems— Local and metropolitan area networks— Specific requirements Part 15.2: Coexistence of Wireless Personal Area Networks with Other Wireless Devices Operating in Unlicensed Frequency Bands," 2003, 126 pp.
- ¹⁶Reg Austin, "Unmanned Air Systems: UAV Design, Development and Deployment," Wiley, June 2010, 372 pp., ISBN: 0470058196.
- ¹⁷Dale Stacey, "Aeronautical Radio Communication Systems and Networks," April 2008, 372 pp., ISBN:978-0-470-01859-0
- ¹⁸Wikipedia, "3GPP Long Term Evolution," http://en.wikipedia.org/wiki/3GPP_Long_Term_Evolution
- ¹⁹RTCA SC223 Committee on Airport Surface Wireless Communications,
<http://www.rtca.org/comm/Committee.cfm?id=133>
- ²⁰The Boeing 737 Technical Site, "Boeing 737 V Speeds," http://www.b737.org.uk/vspeeds.htm#Take-Off_Speeds_