

Trends and Issues in Softwarization of Networks: What's In, What's Out

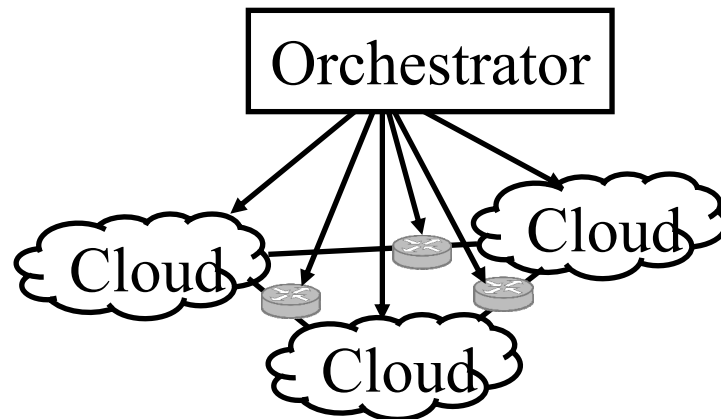

Raj Jain

Washington University in Saint Louis

Jain@wustl.edu

Invited Talk at Hong Kong University of Science and Technology, Hong Kong, Nov. 8, 2018

These slides and recording of this talk are available on-line at:

<http://www.cse.wustl.edu/~jain/talks/hkust18.htm>



1. What has changed in the last five years?
2. What has happened to SDN, NFV, and Clouds?
3. What's in, what's out?

Selecting the Right Problems

- ❑ Important question for **students**, academics, entrepreneurs, and companies
- ❑ Goal: To impact
- ❑ Follow the **paradigm shifts**:
 - 1980: Ethernet
 - 1990: ATM Networks
 - 2000: Optical Networks
 - 2005: Wireless Networks
 - 2010: Next Generation Internet/SDN
 - 2013: Multi-Cloud Computing
 - 2018: Whatever is being **hyped** this year?



Gartner Hype Cycle 2018

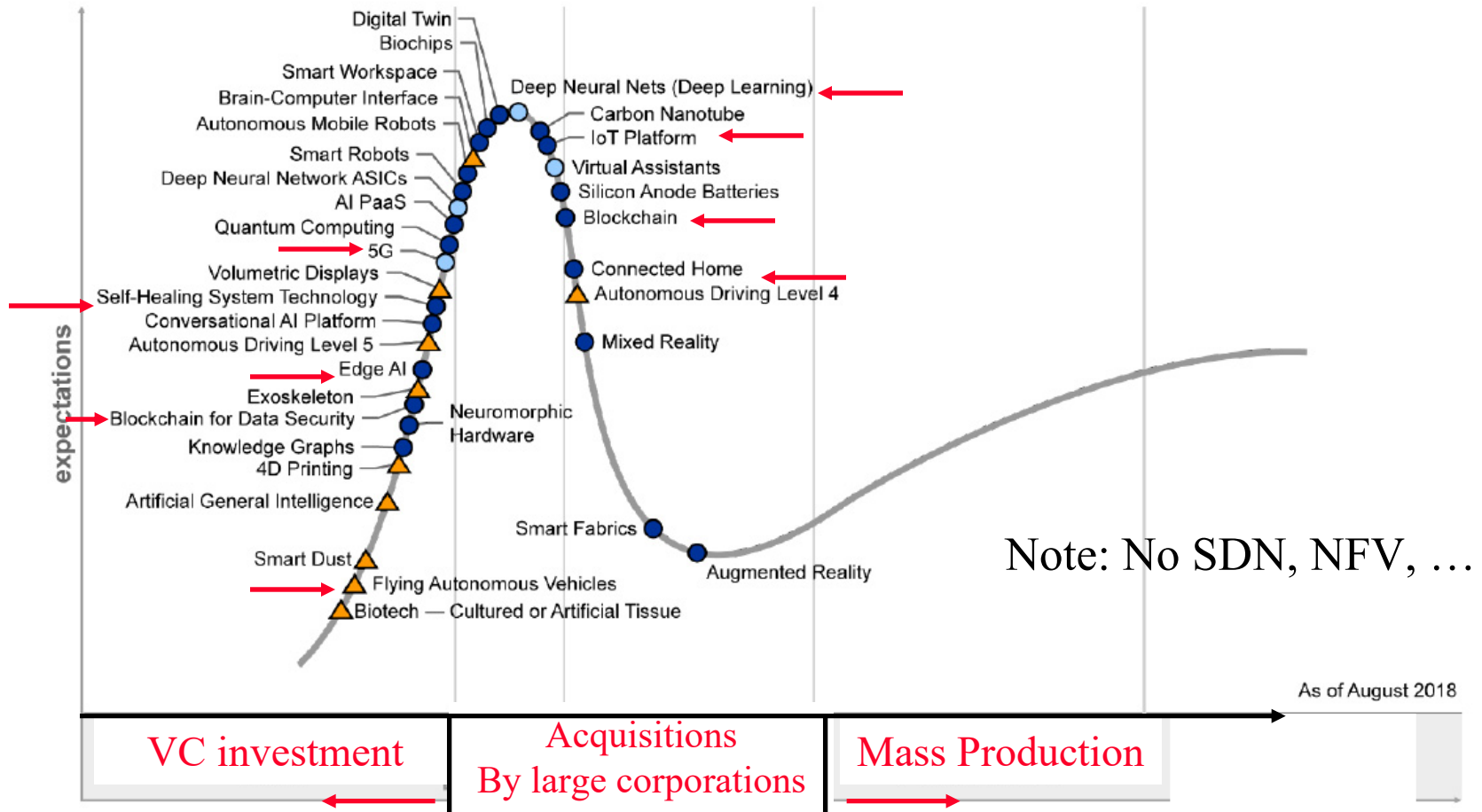

Ref: M. Walker, "Hype Cycle for Emerging Technologies, 2018," Gartner Report G00340159, 6 Aug. 2018, 73 pp.

Trend 1: SDN to Disaggregation

- ❑ SDN was invented in 2009
- ❑ Then: SDN:
 - Separation of control and data planes
 - Centralization of Control
 - Standard Protocol between the planes
- ❑ Now: Software Defined = **Disaggregation** of HW/SW
 - Commodity hardware
 - Software that runs on commodity HW
 - Legacy protocols survive

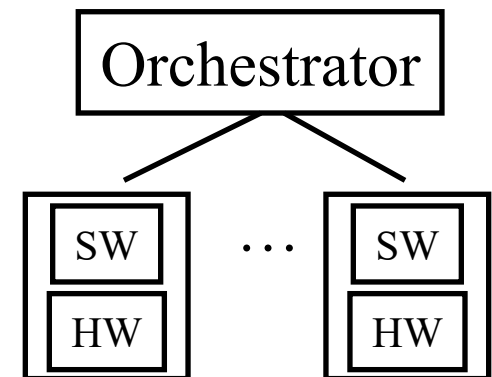
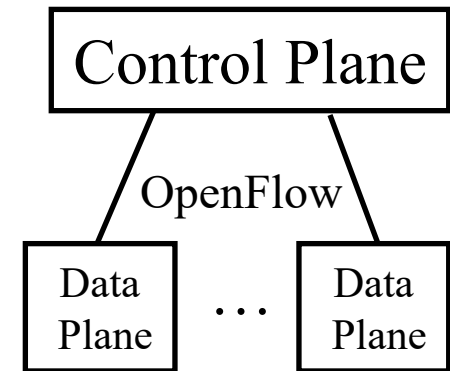

Disaggregation: Black Box to White Box

- ❑ All specialization and differentiation via software
⇒ White box networking
- ❑ **Black Box**: Proprietary HW with Proprietary SW
- ❑ **White Box**: Open Source Hardware and Software
- ❑ Software on a different hardware ⇒ hardware can change
Different software on a hardware ⇒ Software can change
- ❑ **Bright Box**: Branded White box =
Branded SW on open HW or Open SW on Branded HW

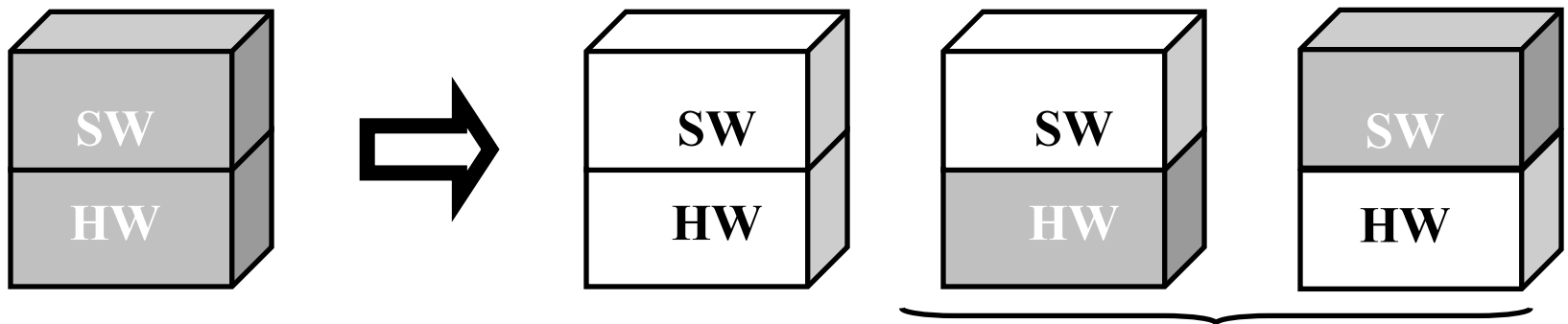

Ref: A. Lerner, “Branded Switching + White-Box Switching = Brite-Box Switching,” Nov 14, 2014,
<https://blogs.gartner.com/andrew-lerner/2014/11/19/britefuture/>

White Box Switches

- ❑ Switches by EdgeCore Networks (ACTON), Quanta, HPE, DNI, Dell, Mellanox, Delta Agema, Celestica, Alpha Networks, Ingrasys, Inventec, Netberg
- ❑ Switching ASICs by Broadcom, Marvell, Intel/Fulcrum, Mellanox, Barefoot, and Cavium
- ❑ CPUs: Intel Rangeley/Atom, Freescale, ARM A9

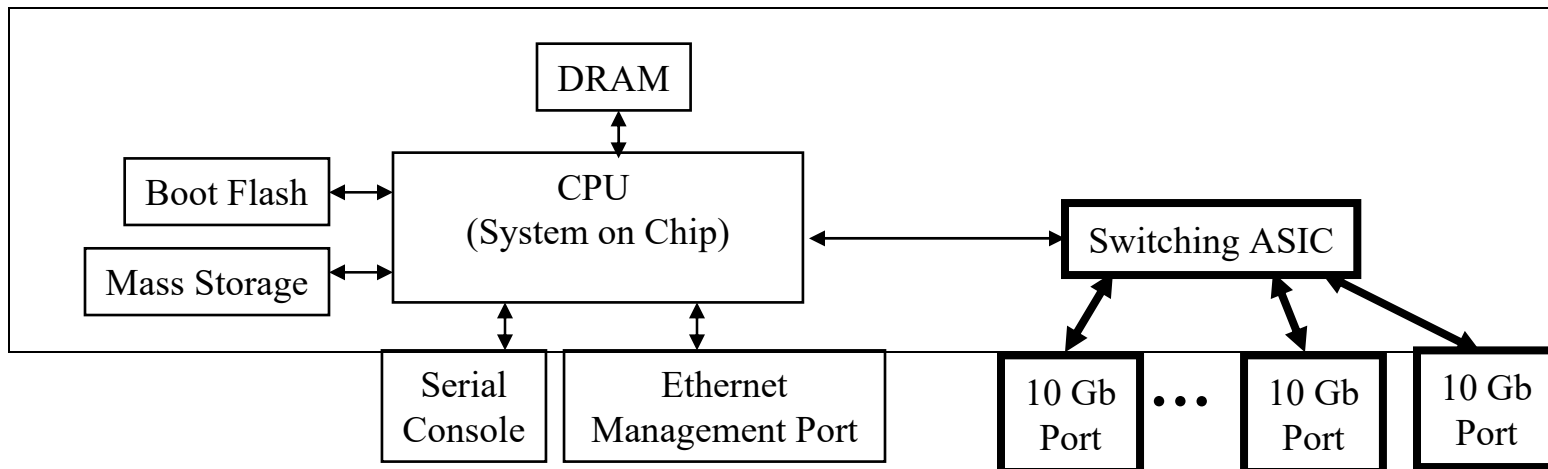

Trend 2: Separation of Control to Orchestration of Policies

Separation and Centralization of Control Plane

Orchestration of Policies



Micromanagement is not scalable

Trend 3: Clouds to Micro-Clouds

- ❑ Cloud computing was invented in 2006
- ❑ Then: Cloud = Large Data Center
Multiple VMs managed by a cloud management system (OpenStack)
- ❑ Today: Cloud = Computing using virtual resources
 - μ Cloud = Cloud in a server with multiple VMs.
 - VMs managed via cloud management SW, e.g., OpenStack

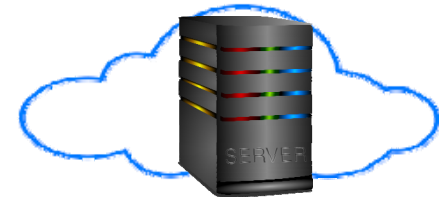

Trend 4: Core to Edge Computing

- To service mobile users/IoT, the computation needs to come to edge \Rightarrow Mobile Edge Computing

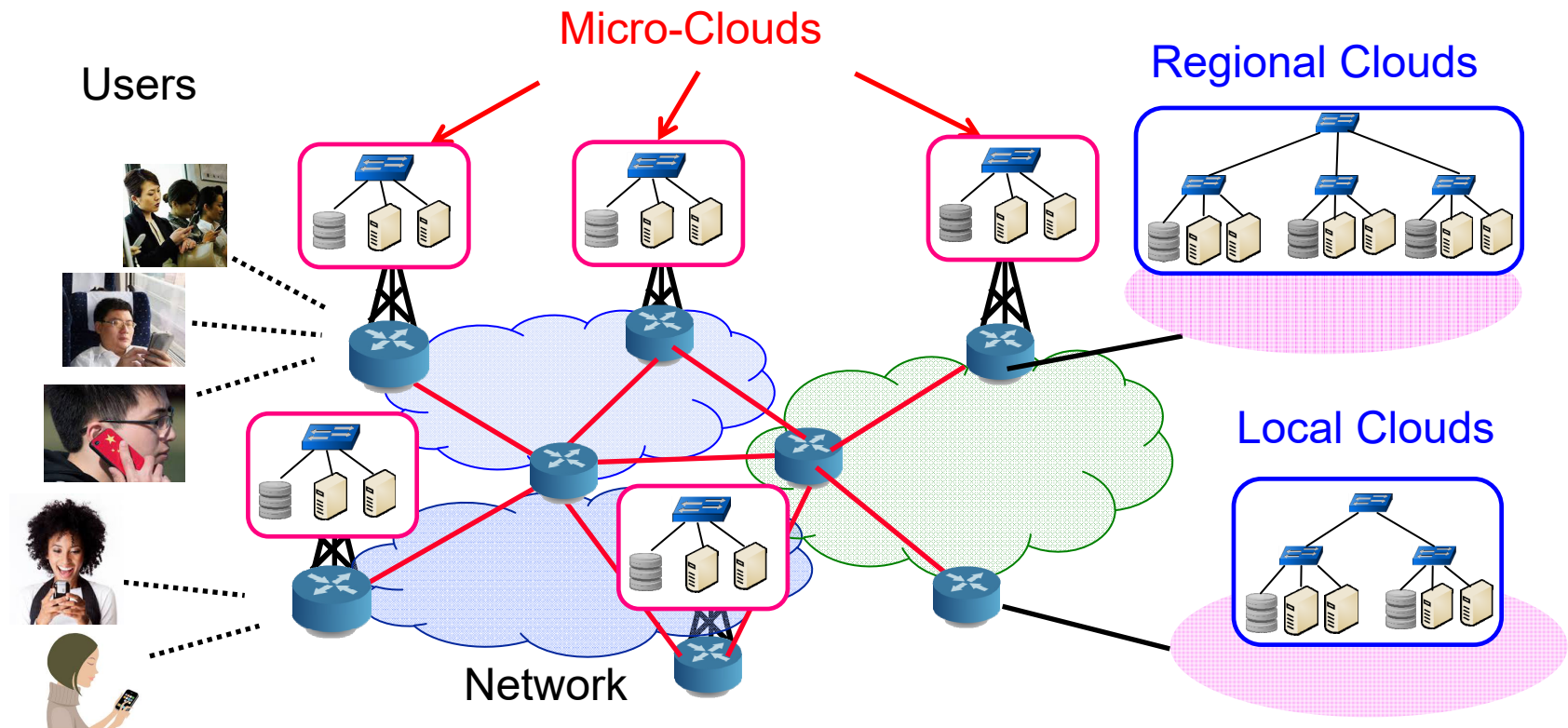

Ref: Lav Gupta, Raj Jain, H. Anthony Chan, "Mobile Edge Computing - an important ingredient of 5G Networks," IEEE Softwarization Newsletter, March 2016, <http://www.cse.wustl.edu/~jain/papers/mec16.htm>

Trend 5: Services to Micro-Services

- ❑ **Decomposition:** Applications are broken in to smaller pieces that can be developed, tested, and run in isolation on multi-clouds

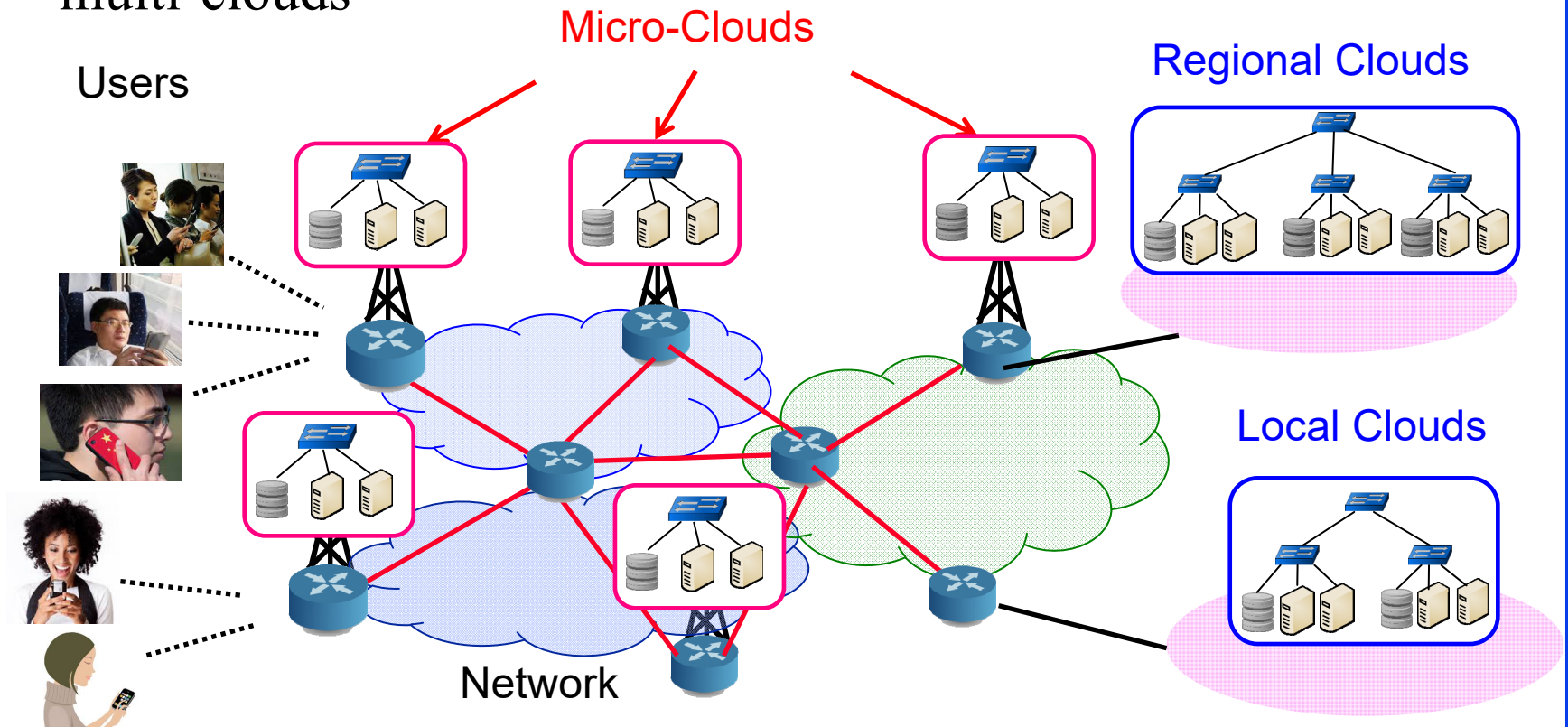

Trend 6: Orchestration of Switches to Orchestration of Multi-Cloud

- ❑ Orchestrating devices to Orchestrating Clouds
- ❑ Micro-Service placement and optimization in multi-clouds

Datacenter Applications

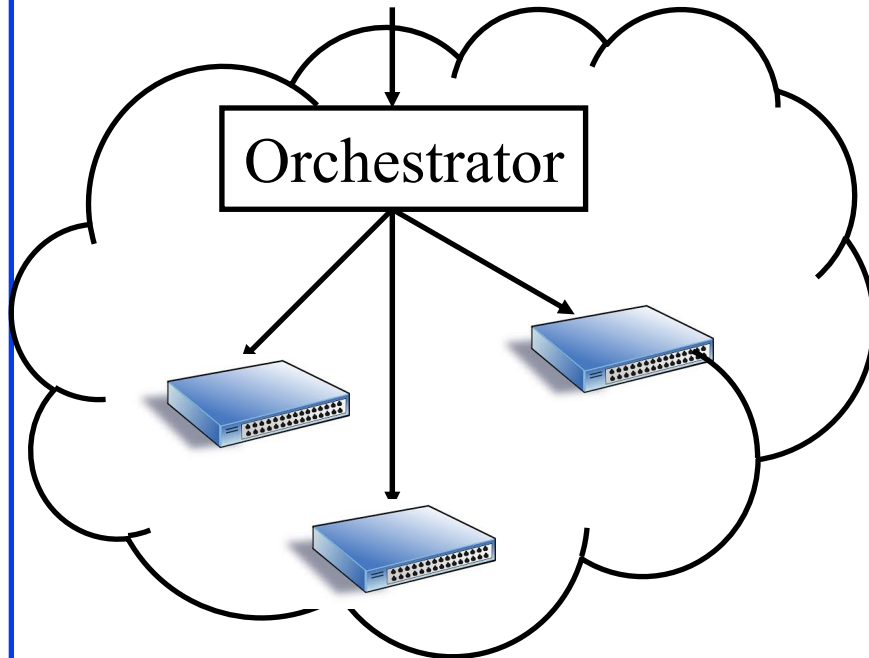

Global Applications

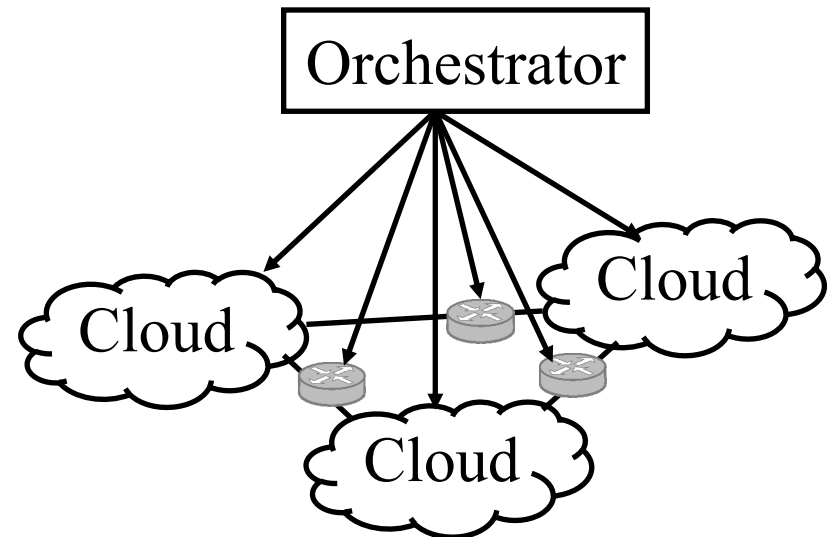

Ref: Subharthi Paul, Raj Jain, Mohammed Samaka, Jianli Pan, "Application Delivery in Multi-Cloud Environments using Software Defined Networking," Computer Networks Special Issue on cloud networking and communications, December 2013,

<http://www.cse.wustl.edu/~jain/papers/comnet14.htm>

Washington University in St. Louis

<http://www.cse.wustl.edu/~jain/talks/hkust18.htm>

©2018 Raj Jain

Network Function Virtualization (NFV)

- Network Functions on Virtual Machines in a cloud

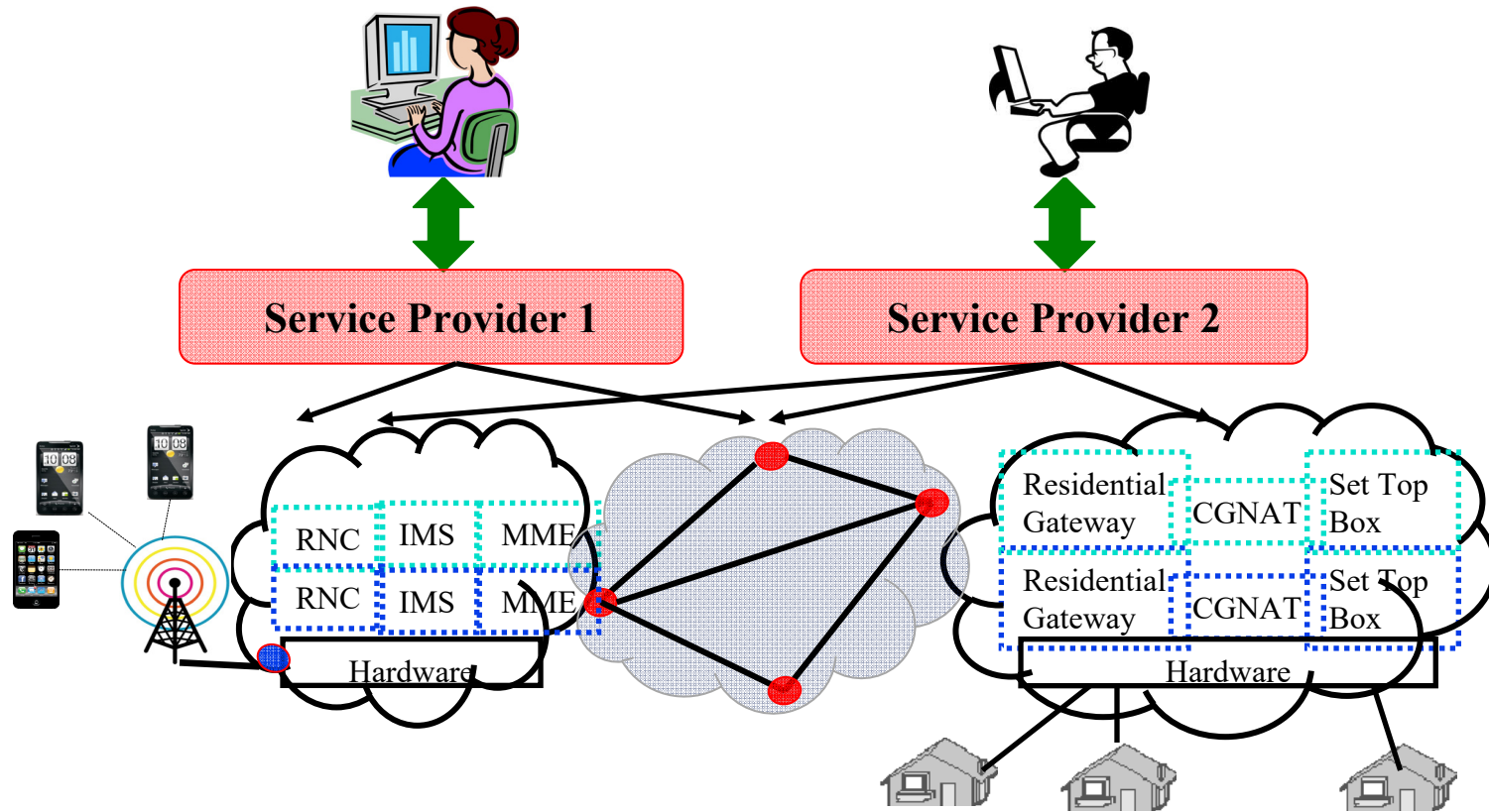

Ref: Raj Jain and Subharthi Paul, "Network Virtualization and Software Defined Networking for Cloud Computing - A Survey," IEEE Communications Magazine, Nov 2013, pp. 24-31, http://www.cse.wustl.edu/~jain/papers/net_virt.htm

Problems with Virtual Machines

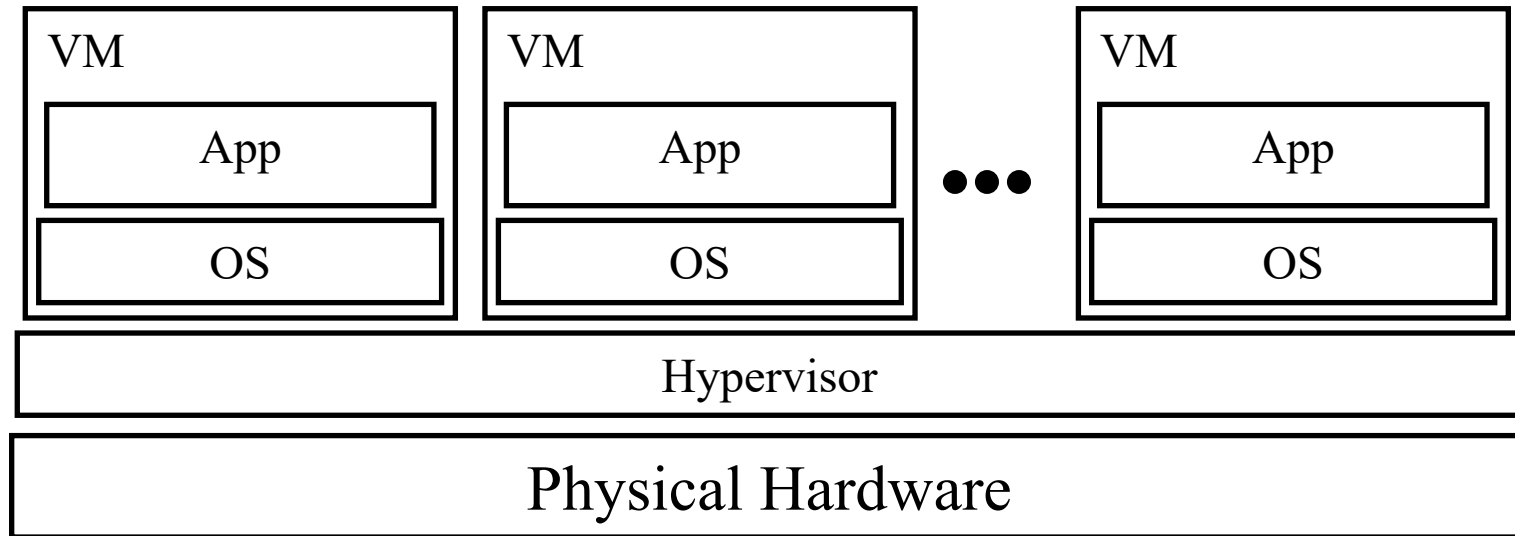

- ❑ Each VM requires an operating system (OS)
 - Each OS requires a license \Rightarrow **CapEx**
 - Each OS has its own compute and storage overhead
 - Needs maintenance, updates \Rightarrow **OpEx**
 - **VM Tax** = added CapEx + OpEx

Trend 7: Virtualization to Containerization

- ❑ Run many apps in the same virtual machine
 - These apps share the OS and its overhead
 - Can't access each other's resources without explicit permission
 - Like apartments in a complex \Rightarrow Containers

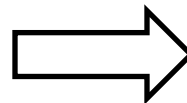

Kata Containers

- ❑ Containers do have less security than VMs
- ❑ Kata Containers = VM + Container hybrid
- ❑ Combines “Intel Clear Containers” and “HyperV runV”
- ❑ Open source project under OpenStack Foundation
- ❑ Performance like containers, isolation and security like VMs
- ❑ Package once and run anywhere
 - VMware, Google, and Amazon are all moving towards this approach

Ref: <https://katacontainers.io/>

<https://www.forbes.com/sites/janakirammsv/2017/12/11/why-kata-containers-is-good-for-the-industry-and-customers/2/#3d8cc2e9404f>

Standards are Slow

- ❑ Initially, Standards \Rightarrow Interoperability
Iff all companies implement the same way
- ❑ Standards = Compromises \Rightarrow We agree to disagree
All differing opinions are part of the standard as option
Different companies choose different options
 \Rightarrow No Interoperability
- ❑ Need Interoperability organizations
 - WiFi \Rightarrow Approves the subset of standard that is mandatory
- ❑ All this introduces delay
 \Rightarrow The standard out of date when it is ready for implementation
- ❑ IEEE 802.11ah-2016 Long-Range WiFi for IoT. Started 2010.
Taken over by competition: ZigBee, LoraWAN, ...

Standards are not Open

- ❑ Open \Rightarrow Anyone can implement it without fee
- ❑ IETF allows “non-discriminatory and reasonable licensing fee”
 \Rightarrow Not really open
- ❑ Open Source Initiative (OSI) Criteria:
 - No intentional secrets
 - Free and publicly available
 - All patents must be royalty-free for unrestricted use
 - No license agreements, NDA, or paperwork to implement
 - Not dependent on non-open standards

Trend 8: Standards to Open Source SW

- ❑ Standardization to Rough Consensus and Running Code
- ❑ IETF has ~100 working groups
Open Linux Foundation has >100 open source networking projects. Their website can't be kept uptodate.
- ❑ 4 Opens:
 - Open Source
 - Open Design
 - Open Development
 - Open Community

Blockchains

- ❑ Blockchain is the technology that made Bitcoin secure
- ❑ Blockchain was invented by the inventor of Bitcoin
- ❑ After Bitcoin became successful, people started looking into the technology behind Bitcoin and found:
 - Blockchain is the key for its success
 - Two complete strangers can complete a transaction/contract without a third party

Example of a Contract: Wedding



Wedding (Cont)

❑ Centralized



- ❑ Centralized registry
- ❑ Single point of failure
- ❑ Easier to hacked

❑ Decentralized



- ❑ Decentralized
- ❑ No single point of failure
- ❑ Very difficult to hack

Trend: Centralized to Distributed

- ❑ **Trend:** Make everything decentralized with no central point of trust
- ❑ Two perfect strangers can exchange money, make a contract without a trusted third party
- ❑ Decentralized systems are
 1. More secure: Attack tolerant
 2. No single bottleneck
 3. More reliable: Fault tolerant
 4. No single point of control \Rightarrow No monopoly
- ❑ Blockchain is one way to do this among **untrusted multi-domain** systems.

Time is a cycle: Distributed vs. Centralized debate

Examples of Centralized Systems

- ❑ **Banks:** Allow money transfer between two accounts
- ❑ **City Records**
- ❑ **Voting Authorities**
- ❑ **Networks:** Certificate Authorities, DNS
- ❑ In all cases:
 1. There is a central third party to be trusted
 2. Central party maintains a large database of information
⇒ Attracts Hackers
 3. Central party may be hacked ⇒ affects millions
 4. Central party is a single point of failure.
Can malfunction or be bribed.

Ref: Tara Salman, Maede Zolanvari, Aiman Erbad, Raj Jain, and Mohammed Samaka, "Security Services Using Blockchains:A State of the Art Survey" IEEE Communications Surveys and Tutorials, Accepted September 2018, 28 pp., <http://www.cse.wustl.edu/~jain/papers/bcs.htm>

Networking Applications of Blockchains

❑ Multi-Domain Systems:

- Multiple Cloud Service Providers
- Multiple cellular providers
- Multi-Interface devices: WiFi, Cell, Bluetooth, ...
- BGP: BGP Authentication

❑ Globally Centralized Systems:

- DNS
- Public Key Infrastructure
 - ❑ Certificate Authorities issue certificates
 - ❑ Single Point of Failure
 - ❑ Example: Diginotar – Dutch CA compromised in 2011

Explore blockchains for multi-domain/centralized systems

Blockchain Challenges

- ❑ High computational cost \Rightarrow 7 bitcoin transactions per second vs. 1,700 visa credit card transactions
- ❑ Software bugs \Rightarrow Stolen money \Rightarrow Forking in Ethereum
- ❑ All data is public in public blockchains

Smart Everything



Smart Watch



Smart TV



Smart Car



Smart Health



Smart Home



Smart Kegs



Smart Space



Smart Industries



Smart Cities

What's Smart?

- ❑ Old: Smart = Can think \Rightarrow Computation
= Can Recall \Rightarrow Storage
- ❑ Now: Smart = Can find quickly, Can Delegate
 \Rightarrow Communicate = Networking
- ❑ Smart Grid, Smart Meters, Smart Cars, Smart homes, Smart Cities, Smart Factories, Smart Smoke Detectors, ...

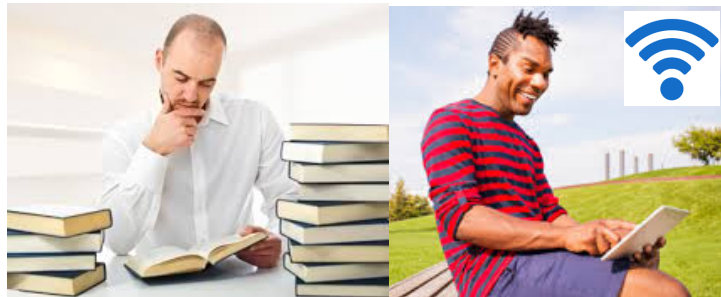

Not-Smart Smart

- ❑ Smart = Apply the latest **technology** to solve problems

Machine Learning Challenges

- ❑ Machine learning is currently a blackbox
- ❑ ML algorithms are developed/used without domain expertise
- ❑ Data cleanliness, labeling, feature extractions, all require domain knowledge, e.g.,
What is the distance between Port 80, Port 81, and Port 8080?
- ❑ Data Imbalance (1 in a million packet is an attack packet).
- ❑ Use Synthetic data is used \Rightarrow Garbage-In, Garbage-Out
- ❑ Results are stated without model validation.
- ❑ Explainability issue \Rightarrow No idea of why the results are what they are

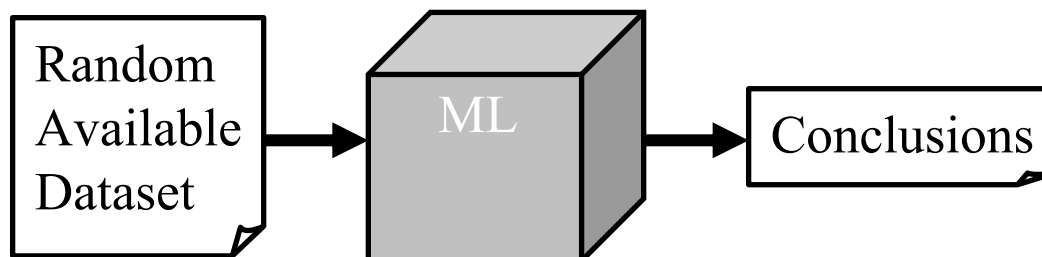

Trend 11: Managed to Self-Driven Networks

- ❑ **Self-Discover:** Find its components
- ❑ **Self-Organize and Self-configure:** Trending. Predict.
- ❑ **Auto-Manage** = Auto-BSS (bill)/Auto-OSS (provision)
- ❑ **Self-Monitor:** Counters and Probes. Telemetry
- ❑ **Self-Diagnose and Self-Heal:** Self-Report to human operator



Network Manager

Intent-Based Policy Management

- ❑ **Intent:** Tell what you want. Not how you want it done.
E.g., Tell Google maps where you want to go. Not how to.
- ❑ **Invariance:** Intent doesn't change if the network changes, devices fail, ...
- ❑ **Portability:** Independent of infrastructure, equipment vendors, service providers, protocols used, media used, ...
- ❑ **Compose-ability:** Can use any infrastructure, ...
- ❑ **Scalable:** From one to billions. Single controllers not scalable.
- ❑ Action requires context: Actions need to adopt to changes in infrastructure
- ❑ OpenDaylight has a new project on Network Intent Composition (NIC)

Ref: <https://www.sdxcentral.com/articles/contributed/network-intent-summit-perspective-david-lenrow/2015/02/>
https://wiki.opendaylight.org/view/Project_Proposals:Network_Intent_Composition

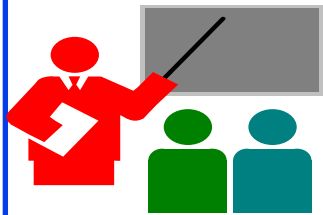

Summary

#	Past	Present/Future
1	SDN	Disaggregation
	Proprietary Black Boxes	Standardized White Boxes
2	Control	Orchestration
3	Clouds	Micro-Clouds
4	Core	Edge
5	Services	Micro-services
6	Orchestration of Switches	Orchestration of Multi-Cloud
7	Virtualization	Containerization
8	Standards	Open-Source SW
9	Centralized	Distributed
10	Smart	Intelligent
11	Managed	Self-Driven

1. Networking is changing faster than PhD research cycles
2. For impact/success, publishing is not sufficient.
Implement your research in open source SW.

Related Papers

Multi-Cloud:

- ❑ Deval Bhamare, Mohammed Samaka, Aiman Erbad, Raj Jain, Lav Gupta, H. Anthony Chan, "**Optimal Virtual Network Function Placement and Resource Allocation in Multi-Cloud Service Function Chaining Architecture**," Computer Communications, Vol. 102, April 2017, pp. 1-16, <http://www.cse.wustl.edu/~jain/papers/comcom17.htm>
- ❑ Deval Bhamare, Raj Jain, Mohammed Samaka, Aiman Erbad, "**A Survey on Service Function Chaining**," Journal of Network and Computer Applications, Vol. 75, Nov 2016, pp. 138-155, <http://www.cse.wustl.edu/~jain/papers/jnca16.htm>
- ❑ Lav Gupta, Prof Raj Jain, Prof Mohammed Samaka, Prof Aiman Erbad, and Dr. Deval Bhamare, "**Performance Evaluation of Multi-Cloud Management and Control Systems**," Recent Advances in Communications and Network Technology, 2016, Vol. 5, Issue 1, pp. 9-18, <http://www.cse.wustl.edu/~jain/papers/racnt.htm>
- ❑ Subharthi Paul, Raj Jain, Mohammed Samaka, Aiman Erbad, "**Service Chaining for NFV and Delivery of other Applications in a Global Multi-Cloud Environment**," 21st Annual International Conference on Advanced Computing and Communications (ADCOM) 2015, Chennai, India, September 18-20, 2015, http://www.cse.wustl.edu/~jain/papers/adn_in15.htm

Related Papers (Cont)

Edge Computing:

- ❑ Lav Gupta, Raj Jain, H. Anthony Chan, "**Mobile Edge Computing - an important ingredient of 5G Networks**," IEEE Softwarization Newsletter, March 2016, <http://sdn.ieee.org/newsletter/march-2016/mobile-edge-computing-an-important-ingredient-of-5g-networks>
- ❑ Deval Bhamare, Aiman Erbad, Raj Jain, Mohammed Samaka, "**Automated Service Delivery Platform for C-RANs**," The IEEE Third International Workshop on Mobile Cloud Computing systems, Management, and Security (MCSMS) 2017, Valencia Spain, May 8-11, 2017, <http://www.cse.wustl.edu/~jain/papers/mcsms17.htm>,

Related Papers (Cont)

Micro-Services:

- ❑ Deval Bhamare, Mohammed Samaka, Aiman Erbad, Raj Jain, Lav Gupta, **"Exploring Micro-Services for Enhancing Internet QoS,"** Transactions on Emerging Telecommunications Technologies, Accepted June, 2018, ISSN: 2161-3915, DOI: 10.1002/ett.3445, http://www.cse.wustl.edu/~jain/papers/ms_ett18.htm
- ❑ Deval Bhamare, Aiman Erbad, Raj Jain, Maede Zolanvari, Mohammed Samaka, **"Efficient Virtual Network Function Placement Strategies for Cloud Radio Access Networks,"** Computer Communications, Volume 127, May 2018, pp. 50-60, ISSN 0140-3664, DOI: [10.1016/j.comcom.2018.05.004](https://doi.org/10.1016/j.comcom.2018.05.004)
- ❑ Deval Bhamare, Mohammed Samaka, Aiman Erbad, Raj Jain, Lav Gupta, H. Anthony Chan, **"Multi-Objective Scheduling of Micro-Services for Optimal Service Function Chains,"** International Conference on Communications (ICC 2017), May 21-25, 2017, <http://www.cse.wustl.edu/~jain/papers/icc17.htm>

Related Papers (Cont)

Micro-Services (Cont):

- Deval Bhamare, Raj Jain, Mohammed Samaka, Gabor Vaszkun, Aiman Erbad, "**Multi-Cloud Distribution of Virtual Functions and Dynamic Service Deployment: OpenADN Perspective**," 2015 IEEE International Conference on Cloud Engineering (IC2E), Tempe, AZ, March 9-13, 2015, pp. 299-304, http://www.cse.wustl.edu/~jain/papers/vm_dist.htm
- Deval Bhamare, Raj Jain, Mohammed Samaka, Aiman Erbad, "**A Survey on Service Function Chaining**," Journal of Network and Computer Applications, Vol. 75, Nov 2016, pp. 138-155, ISSN: 10848045, DOI: 10.1016/j.jnca.2016.09.001, <http://www.cse.wustl.edu/~jain/papers/jnca16.htm>

Related Papers (Cont)

AI for Networking:

- ❑ Lav Gupta, M. Samaka, Raj Jain, Aiman Erbad, Deval Bhamare, H. Anthony Chan, "**Fault and Performance Management in Multi-Cloud Based NFV using Shallow and Deep Predictive Structures**," 26th International Conference on Computer Communications and Networks (ICCCN 2017), Vancouver, Canada, July 31-Aug 3, 2017, <http://www.cse.wustl.edu/~jain/papers/icccn17.htm>
- ❑ Tara Salman, Deval Bhamare, Aiman Erbad, Raj Jain, Mohammed Samaka, "**Machine Learning for Anomaly Detection and Categorization in Multi-cloud Environments**," The 4th IEEE International Conference on Cyber Security and Cloud Computing (IEEE CSCloud 2017), New York, June 26-28, 2017, <http://www.cse.wustl.edu/~jain/papers/cscloud.htm>
- ❑ Lav Gupta, Mohammed Samaka, Raj Jain, Aiman Erbad, Deval Bhamare, Chris Metz, "**COLAP: A Predictive Framework for Service Function Chain Placement in a Multi-cloud Environment**," The 7th IEEE Annual Computing and Communication Workshop and Conference (CCWC), Las Vegas, Jan 9-11, 2017, http://www.cse.wustl.edu/~jain/papers/clp_ccwc.htm
- ❑ Deval Bhamare, Tara Salman, Mohammed Samaka, Aiman Erbad, Raj Jain, "**Feasibility of Supervised Machine Learning for Cloud Security**," 3rd International Conference on Information Science and Security (ICISS2016), December 19th - 22nd, 2016, Pattaya, Thailand,, <http://www.cse.wustl.edu/~jain/papers/iciss16.htm>

Related Papers (Cont)

IoT:

- ❑ Tara Salman, Raj Jain, "A Survey of Protocols and Standards for Internet of Things," Advanced Computing and Communications, Vol. 1, No. 1, March 2017, http://www.cse.wustl.edu/~jain/papers/iot_accs.htm

Blockchain:

- ❑ Tara Salman, Maede Zolanvari, Aiman Erbad, Raj Jain, and Mohammed Samaka, "Security Services Using Blockchains: A State of the Art Survey" IEEE Communications Surveys and Tutorials, September 2018, 28 pp., <http://www.cse.wustl.edu/~jain/papers/bcs.htm>
- ❑ Tara Salman, Raj Jain, and Lav Gupta, "Probabilistic Blockchains: A Blockchain Paradigm for Collaborative Decision-Making," 9th IEEE Annual Ubiquitous Computing, Electronics & Mobile Communication Conference (UEMCON 2018), New York, NY, November 8-10, 2018, 9 pp., http://www.cse.wustl.edu/~jain/papers/psc_uem.htm

Related Talks/Class Lectures

- ❑ Raj Jain, “**CSE 570: Recent Advances in Networking,**” Spring 2018, <http://www.cse.wustl.edu/~jain/cse570-18/index.html>
- ❑ Raj Jain, "**Blockchains: Networking Applications,**" An invited talk at the 38th IEEE Sarnoff Symposium, Newark, NJ, Sep 19, 2017, http://www.cse.wustl.edu/~jain/talks/blc_srnf.htm
- ❑ Raj Jain, "**The Catch-up Game: Quest for the Impact,**" Keynote at ACM SIGCOMM 2017, Los Angeles, CA, August 22, 2017, <http://www.cse.wustl.edu/~jain/talks/sigcomm.htm>
- ❑ Raj Jain, "**Recent Advances in Networking and their Impact on Smart Cities,**" Keynote at 4th IEEE International Smart Cities Conference (ISC2), Kansas City, MO, September 16-19, 2018, <http://www.cse.wustl.edu/~jain/talks/smrtciti.htm>

List of Acronyms

- ❑ API Application Programming Interface
- ❑ CapEx Capital Expenditure
- ❑ CE Community Edition
- ❑ CLI Command Language Interface
- ❑ CNCF Cloud Native Computing Foundation
- ❑ DCT Docker Content Trust
- ❑ EE Enterprise Edition
- ❑ ID Identifier
- ❑ OCI Open Cloud Initiative
- ❑ OpEx Operational Expenses
- ❑ OS Operating System
- ❑ TCP Transmission Control Protocol
- ❑ VM Virtual Machine
- ❑ VXLAN Virtual eXtended Local Area Network

Scan This to Download These Slides



rajjain.com