

Protocols for Multimedia on the Internet

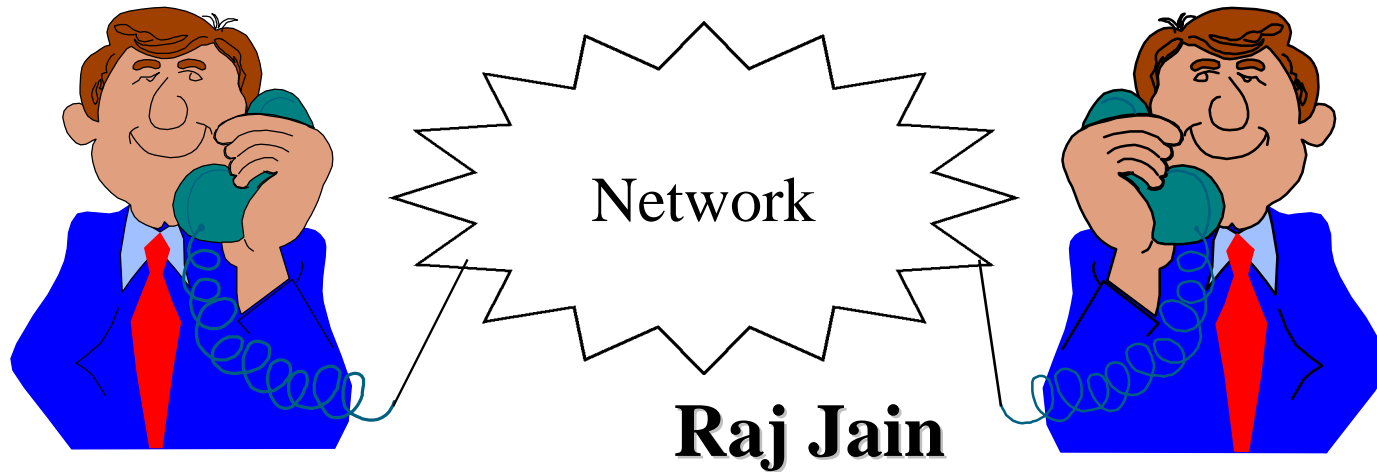

Raj Jain is now at
Washington University in Saint Louis
Jain@cse.wustl.edu
<http://www.cse.wustl.edu/~jain/>



- ❑ Integrated services
- ❑ Resource Reservation Protocol: RSVP
- ❑ Integrated Services over ATM
- ❑ RSVP over ATM
- ❑ Real-time Transport Protocol: RTP, RTCP
- ❑ Real-Time Streaming Protocol: RTSP

Multimedia on the Internet

- ❑ Specify source traffic requirements
- ❑ Protocols to create and maintain resource reservations
- ❑ Routing protocols that support QoS and multicast
- ❑ Transport protocols for error and flow control
- ❑ Access control
- ❑ Packet scheduler to provide QoS

Multimedia on the Internet

- ❑ Specify source traffic requirements
Flow specs from INTSERV working group
- ❑ Protocols to create and maintain resource reservations: *RSVP*
- ❑ Routing protocols that support QoS and multicast
MOSPF, IGMP
- ❑ Transport protocols for error and flow control: *RTP*
- ❑ Access control: *Connection admission based on usage, packet dropping*
- ❑ Packet scheduler to provide QoS:
Weighted Fair Queueing

IGMP

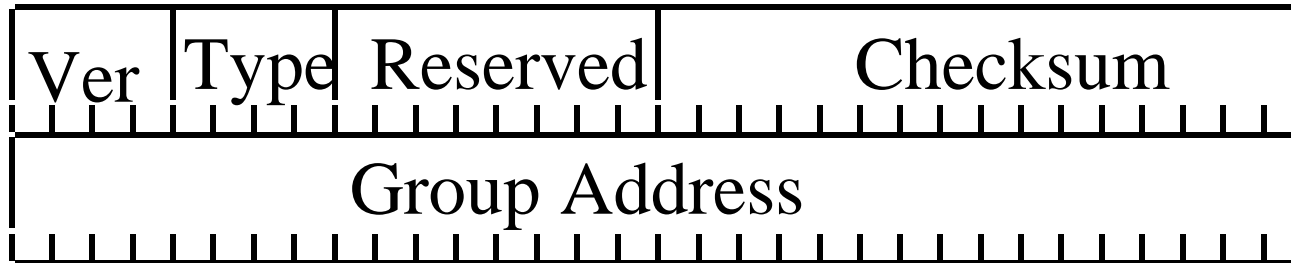

- ❑ Internet Group Management Protocol
- ❑ Used by hosts to report multicast membership
- ❑ Join-IP-Multicast Group (address, interface)
- ❑ Leave-IP-Multicast Group (address, interface)
- ❑ Ref: RFC 1112 (Version 1)

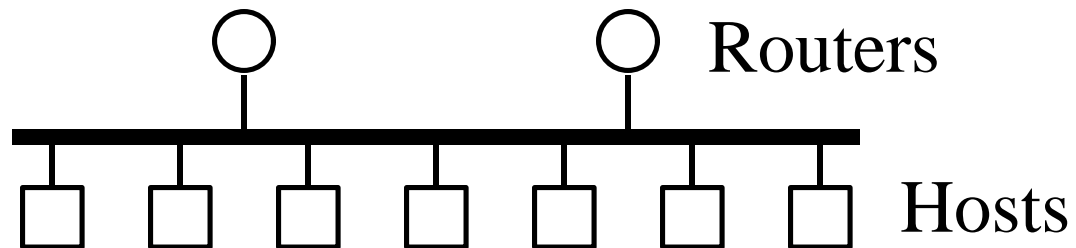

IGMP Operation

- ❑ One "Querier" router per link
- ❑ Every 60-90 seconds, querier broadcasts "query" to all-systems (224.0.0.1) with TTL = 1
- ❑ After a random delay of 0-10 seconds, hosts respond for each multicast group
- ❑ Everyone hears responses and stops the delay timer
⇒ One response per group
- ❑ Non-responding groups are timed-out
- ❑ IGMP V2 is an internet-draft.
IGMP V3 is being designed.

Integrated Services

- ❑ Best Effort Service
- ❑ Controlled-Load Service: Performance as good as in an unloaded datagram network. No quantitative assurances. (Min throughput)
- ❑ Guaranteed Service:
 - Firm bound on data throughput and delay.
 - Every element along the path must provide delay bound.
 - Is not always implementable, e.g., Ethernet.
 - Delay jitter or average delay not guaranteed or minimized.

Flow Specification

- ❑ Flow Spec = Traffic Spec + QoS Spec
= TSpec + RSpec
- ❑ TSpec: Peak rate (p), bucket rate (r), bucket size (b), max datagram size (M), min policed unit (m)
 - All datagrams less than m are counted as m bytes
 - Peak rate may be unknown or unspecified
- ❑ RSpec: Allocated Rate (R) and delay slack (S)
 S = Extra acceptable delay over that obtainable with R
Zero slack \Rightarrow Reserve exactly R .
- ❑ RSpec specified only for guaranteed rate service.
Not for controlled load service.

IS-Capable Router Components

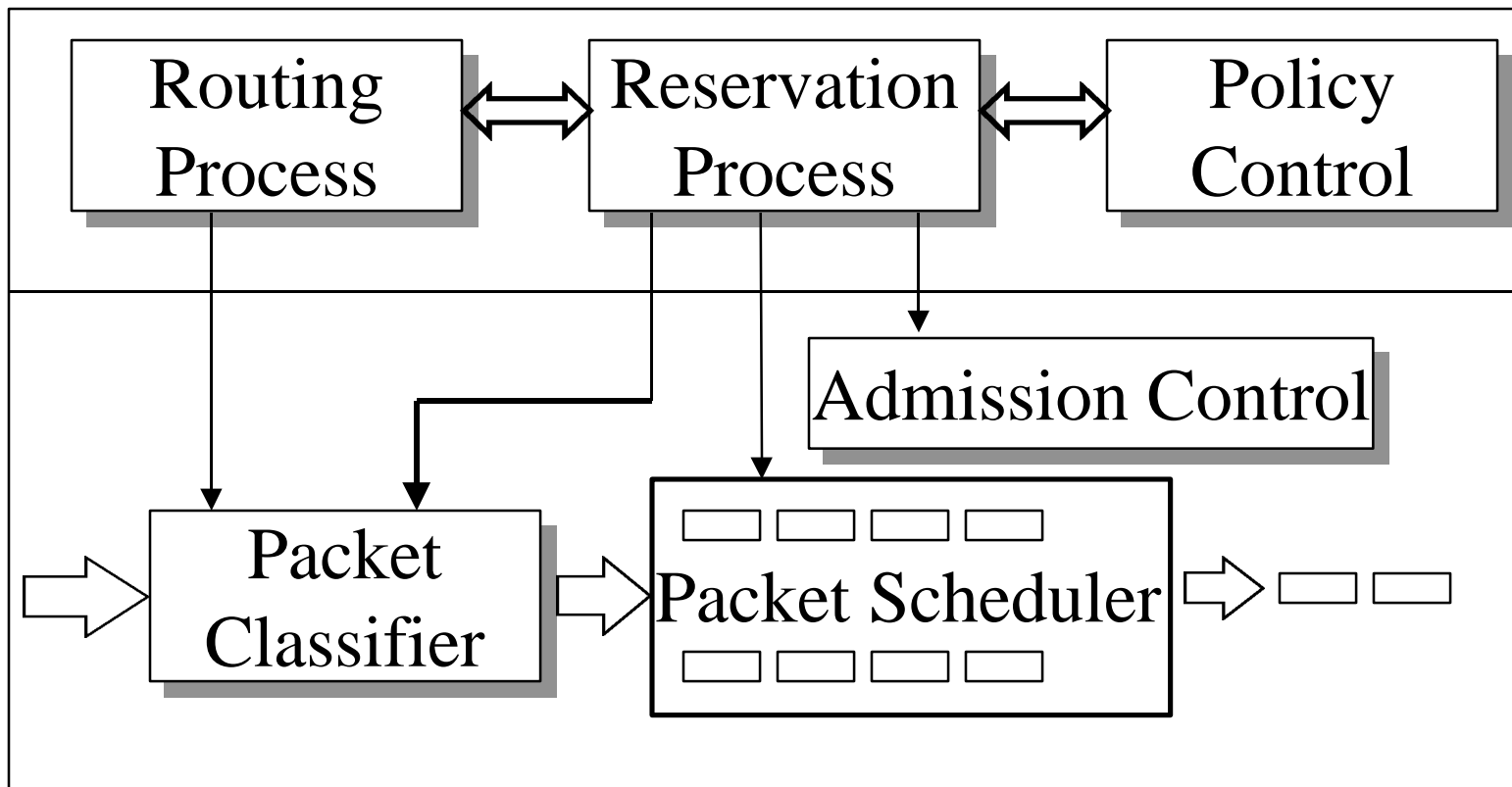

IS Router Components (Cont)

- ❑ Packet Scheduler:
Manages queues and timers for different streams
- ❑ Classifier:
Each incoming packet is examined to determine its class
Packets in the same flow may have “preemptable” (CLP) attribute
- ❑ Admission Control: Determine whether a new flow can be granted without affecting existing flows
- ❑ Reservation Setup Protocol: RSVP

RSVP

- ❑ Resource ReSerVation Protocol
- ❑ Internet signaling protocol
- ❑ Carries resource reservation requests through the network
- ❑ Receiver initiated reservations \Rightarrow Scales well
- ❑ Sets up reservations at each hop
- ❑ RSVP does not find routes.
Multicast routing protocols do.

Path Messages

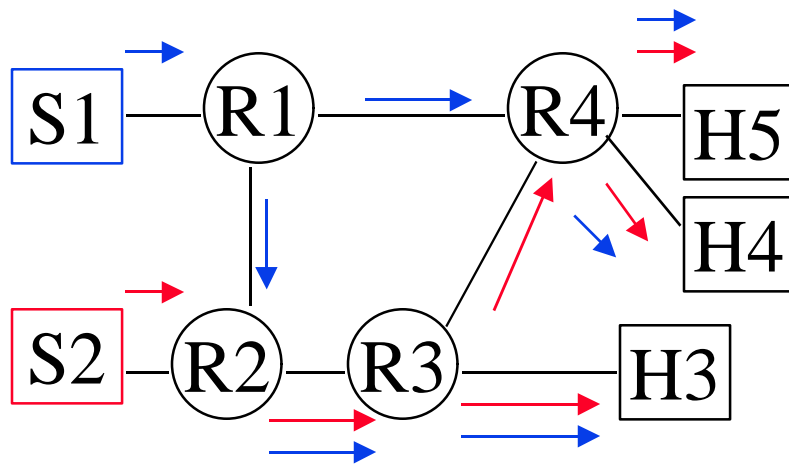

- ❑ Sources send quasi-periodic PATH messages to multicast address
- ❑ Path message contain “Flow spec”:
 - Sender Template: Data format, Src Address, Src Port
 - TSpec: Traffic Characteristics. Not changed.
 - ADSpec: Network path resource/service availability Accumulated along the path.

Reservation Requests

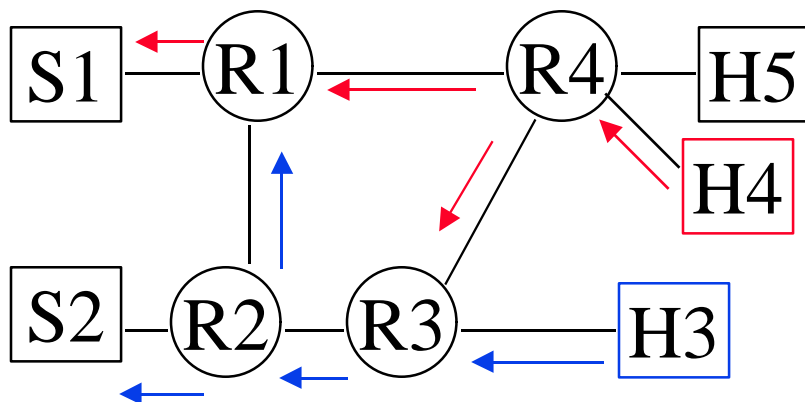

- ❑ Receivers must join multicast address to receive path messages
- ❑ Receivers generate reservation (RESV) requests
- ❑ RESV messages contain resources to be reserved
- ❑ RESV messages are forwarded along the reverse path of PATH messages

Reservation (Cont)

- ❑ Requests are checked for resource availability (admission control) and administrative permissions (policy control)
- ❑ Two or more RESV messages for the same source over the same link are merged.
- ❑ Routers maintain a soft state.
The receivers have to refresh periodically.
- ❑ Heterogeneous Receivers: Sources divide traffic into several flows. Each flow is a separate RSVP flow. Receivers join one or more flows. Each RSVP flow is homogeneous.

Reservation (Cont)

- ❑ ResV messages contain Flow Spec + Filter Spec
- ❑ Filter Spec: Defines the packets in the flow
Used in packet classifier
- ❑ Flow Spec: Used in packet scheduler
Contents depends upon the service.
Will generally include TSpec and RSpec.

RSVP Reservation Styles

Source Selection	Reservation Usage	
	Separate	Shared
Wildcard	N/A	Wildcard Filter
Explicit	Fixed Filter	Shared-Explicit

- ❑ Fixed Filter: One pipe per source
- ❑ Wildcard Filter: One pipe for all sources on a session
- ❑ Shared-Explicit: Sources explicitly identified (Reserve for sources S3 or S4)

RSVP: Status

- ❑ Still an internet draft (Sep 1997)
Submitted to IESG area director.
- ❑ Multivendor interoperability demo at Sep'95 Interop.
- ❑ Product announced by Cisco.
- ❑ Unresolved Issues:
 - Accounting and charging
 - Authentication and access control
 - Session groups

RSVP vs UNI

Category	IP/RSVP	ATM UNI 3.0
Orientation	Receiver based	Sender based
State	Soft	Hard
QoS Setup time	Separate from route establishment	Concurrent with route establishment
Directionality	Unidirectional	Unidirectional multicast
Heterogeneity	Receiver heterogeneity	Uniform QoS to all receivers

- UNI 4.0 adds leaf initiated join.

Integrated Services on ATM

- Guaranteed service:
Peak rate, rate, and bucket depth for sender and
Peak rate, rate, and bucket depth for receiver
 $p_s, r_s, b_s, p_r, r_r, b_r$
- Separate sender and receiver specs allow receiver heterogeneity
- Receiver Rspec also has an allocated rate $R \geq r_r$ to reduce delay

Int. Services on ATM



- ❑ Guaranteed service = rtVBR (or CBR)
PCR = p_r , SCR = R , MBS = b_r
- ❑ Controlled load service
= nrtVBR (or ABR with MCR)
PCR = p_r , SCR = r_r , MBS = b_r
- ❑ Best effort = UBR (or ABR)
- ❑ Excess can be carried on a separate VC
- ❑ ATM rate should be 10% higher than IP rates to account for 5 byte header/48 byte payload

RSVP over ATM

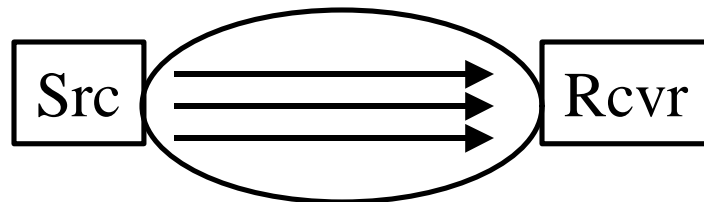

- ❑ RSVP control messages on QoS or best effort VCs?
- ❑ Multiple RSVP sessions on one QoS VC?
- ❑ RSVP control is receiver oriented
 - ⇒ Receiver generates RESV messages.
 - ⇒ In ATM, either the subnet sender sets-up the VC or the receiver sets up the VC with backward direction traffic parameters (Not in pt-mpt VCs)
- ❑ VC Teardown: No explicit RSVP close ⇒ timeout

RSVP Over ATM (Cont)

- ❑ Dynamic QoS:
RSVP allows QoS modification.
ATM does not \Rightarrow Need new VC setup.
Use old VC until the new VC is setup.
- ❑ Encapsulation: LLC encapsulation.
If only IP, VC based multiplexing is better

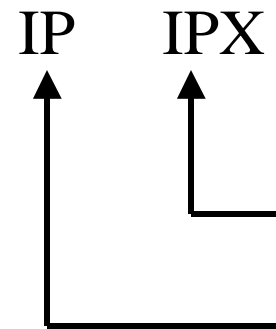
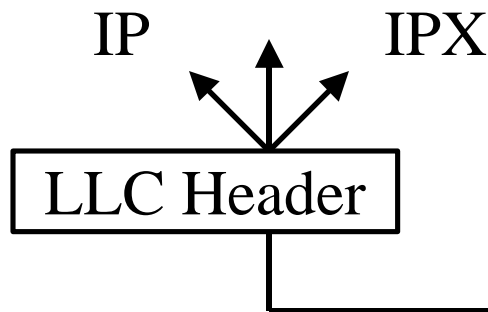

RSVP Multicast over ATM

- ❑ QoS Heterogeneity
- ❑ End-point identification
- ❑ Multicast data distribution
- ❑ Multicast receiver transitions

QoS Heterogeneity

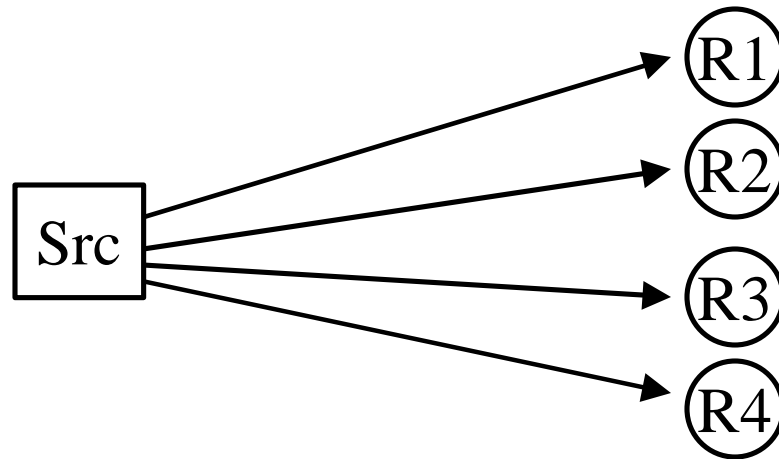

- ❑ Use a different VC for each QoS?
- ❑ If one VC, who pays?
- ❑ If a new receiver comes in with a larger QoS:
Increase the QoS before accepting the receiver.

End-point Identification

- ❑ Multicast end-points may not be identified if egress is tunneled
(NHRP gives next hop only for unicast addresses)

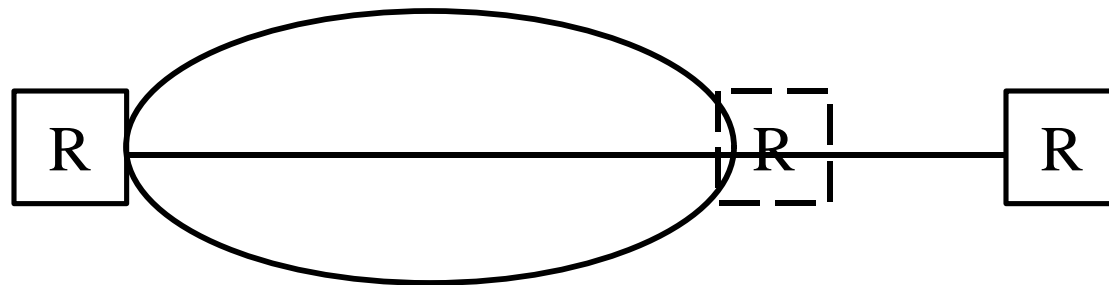

Multicast Data Distribution

- ❑ QoS \Rightarrow Use VC mesh
- ❑ Multicast Server (MCS) \Rightarrow No QoS
 \Rightarrow Set break bits indicating service not supported
- ❑ LANE 1.0 \Rightarrow No QoS

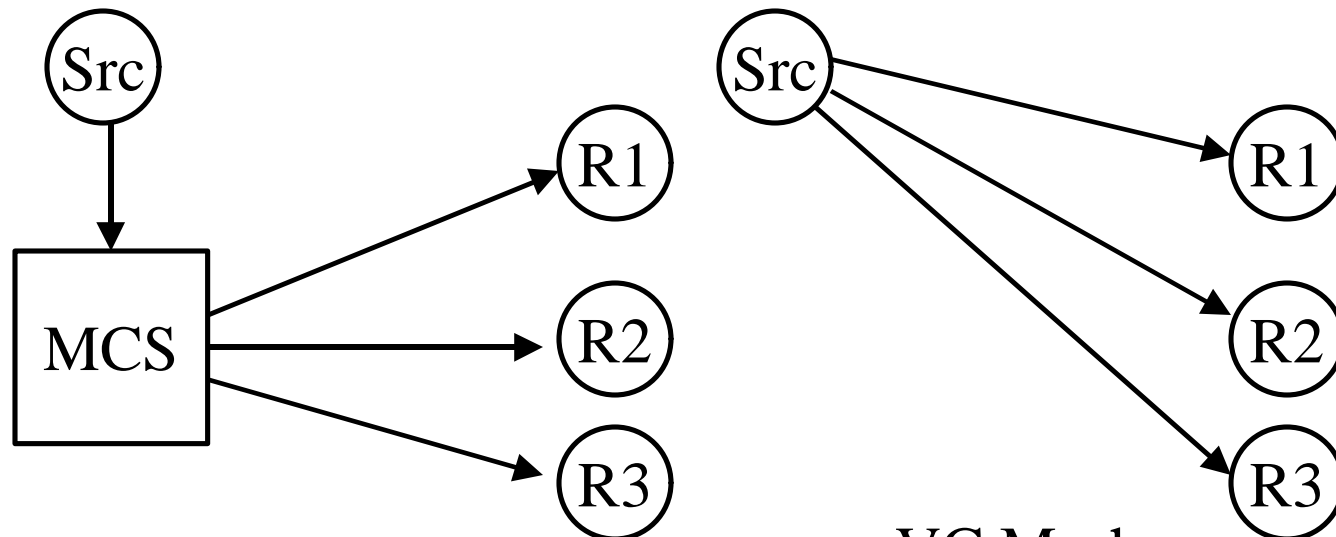

Multicast Receiver Transitions

- ❑ Partially set new QoS pt-mpt VC.
- ❑ Should the data be sent to old, new, or both VCs?
 - Both \Rightarrow Duplicate, One \Rightarrow Loss.
 - Rule: Use old VC until all nodes have been added \Rightarrow No duplication
- ❑ Moving a VC from one QoS to another.
 - Should add (remove) be done first?
 - Rule: Add first \Rightarrow Duplicates.

RSVP Control Management

- ❑ PATH messages to Multicast.
RESV messages to unicast.
⇒ Need both multicast and unicast VCs.
- ❑ Can data use the same signaling VCs?
- ❑ Can different flow share these signaling VCs?
- ❑ Should these be multiple point-to-point VCs or point-to-multipoint VCs?

Desired Changes to ATM

- ❑ Heterogeneous Point-to-Multipoint:
Variegated VCs
- ❑ QoS renegotiation
- ❑ Group Address
- ❑ Lightweight Signaling

Summary

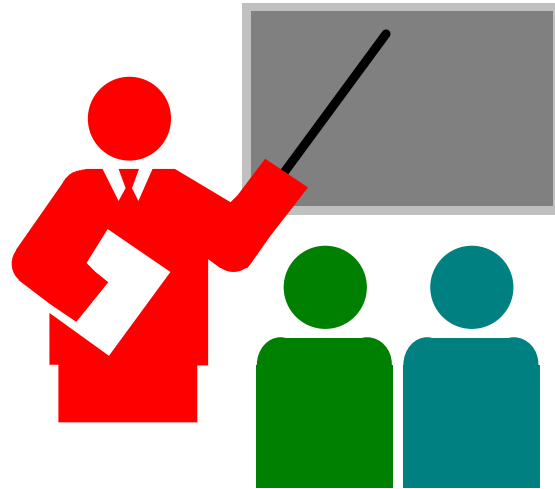

- ❑ TCP/IP protocols suite is being extended to allow multimedia on Internet
- ❑ Signaling protocol: RSVP
- ❑ Integrated Services: GS = rtVBR, CLS = nrtVBR
- ❑ RSVP over ATM: Many issues
- ❑ “Transport” Protocol: RTP, RTCP, RTSP

References

- ❑ For a detailed list of references see:
http://www.cis.ohio-state.edu/~jain/refs/mul_refs.htm
- ❑ "Specification of Guaranteed Quality of Service", 7/7/1997, <http://www.internic.net/internet-drafts/draft-ietf-intserv-guaranteed-svc-08.txt>
- ❑ "Specification of the Controlled-Load Network Element Service", 5/29/1997, <http://www.internic.net/internet-drafts/draft-ietf-intserv-ctrl-load-svc-05.txt>

References (Cont)

- ❑ "Resource ReSerVation Protocol (RSVP) -- Version 1 Functional Specification", 6/16/1997, <http://www.internic.net/internet-drafts/draft-ietf-rsvp-spec-16.txt>
- ❑ RFC 1889, RTP: A Transport Protocol for Real-Time Applications
- ❑ "Real Time Streaming Protocol (RTSP)", 08/02/1997, <http://www.internic.net/internet-drafts/draft-ietf-mmusic-rtsp-03.txt>

References (Cont)

- ❑ The MBONE information web,
<http://www.mbone.com/>
- ❑ RFC 1819, Internet Stream Protocol Version 2 (ST2) Protocol Specification - Version ST2+
- ❑ SDP: Session Description Protocol,
3/26/97, [http://www.internic.net/
internet-drafts/draft-ietf-mmusic-sdp-03.txt](http://www.internic.net/internet-drafts/draft-ietf-mmusic-sdp-03.txt)

References

- ❑ Voice Over IP (VoIP) Forum mailing list:
voip-tech-request@vocaltec.com
- ❑ E. Crawley, et al, "A Framework for Integrated Services and RSVP over ATM," draft-ietf-issll-atm-framework-00.txt, July 24, 1997

IETF Multimedia Working Groups

- ❑ Audio/Video Transport (avt)
- ❑ Integrated Services (intserv)
- ❑ Integrated Services over Specific Link Layers (issll)
- ❑ Resource Reservation Setup Protocol (rsvp)
- ❑ MBONE deployment working group (mboned)
- ❑ Multiparty Multimedia Session Control (mmusic)
- ❑ Multicast Extensions to OSPF (mospf)
- ❑ Inter-Domain Multicast Routing (idmr)

Working Groups (Cont)

- QoS-based Routing (qosr)

RTP

- ❑ Real-Time “Transport” Protocol
- ❑ Not really an L4 protocol.
Common parts of several applications.
Uses UDP for multiplexing and checksum.
- ❑ Supports unicast and multicast delivery
- ❑ Source and payload type identification
- ❑ Sequencing, Timing, and Synchronization
- ❑ Source merging: Multiple contributing sources for a combined stream produced by an RTP mixer.
32-bit Synchronizing source (SSRC) id.
- ❑ Stream translation: High-speed to low speed

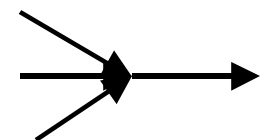

RTP (Cont)

- ❑ What RTP Does not Do?
 - Reliable data delivery
 - Quality of service guarantees
 - Resource reservations (RSVP)
 - Delivery of encryption key to participants
- ❑ RTP provides a general framework for applications to be able to do these ⇒ Application Level Framing
- ❑ Two components: RTP and Control (RTCP)
⇒ Simple RTP header
- ❑ Particular codings need additional parameters
⇒ RTP Profiles documents

RTCP

- ❑ Real-Time Transport Control Protocol
- ❑ Convey information about participants
- ❑ Convey information about relationships among sessions
- ❑ Monitor application performance
⇒ Feedback on quality of data
- ❑ Automatically adjusts overhead
(Report frequency based on participant count)

RTCP Packet Types

- ❑ Sender Report (SR):
Packets/bytes sent, lost
- ❑ Receiver Report (RR):
Packets/bytes received, lost, jitter
- ❑ Source Description (SDES)
- ❑ End of participation (BYE)
- ❑ Application Specific functions (APP)

RTSP

- ❑ Real time streaming protocol
- ❑ Application level protocol similar to hyper-text transfer protocol (HTTP/1.1) for audio/video
- ❑ Maintains state \Rightarrow Setup/teardown messages
- ❑ RTSP messages use TCP, UDP, ...
- ❑ Data transfer is done separately using TCP, RTP/UDP, ...
- ❑ Uses URLs, e.g.,
`rtsp://media.example.com:554/twister/audiotrack`
- ❑ Both servers and clients can issue requests.
HTTP servers do not issue requests.

RTSP Methods

- ❑ Setup: Start a new session
- ❑ Teardown
- ❑ Redirect
- ❑ Play
- ❑ Record
- ❑ Pause
- ❑ Describe: Tell me about session X
- ❑ Announce: A session X will take place at t
- ❑ Get_parameter: Get server/client statistics
- ❑ Set_parameter
- ❑ Options: I can accept only these options.