

Passive Optical Networks: Recent Developments and Issues

Raj Jain

CT
N
18
San

Raj Jain is now at
Washington University in Saint Louis
Jain@cse.wustl.edu
<http://www.cse.wustl.edu/~jain/>

Professor
University
I 43210-1277

Invited Presentation at
Optical Transmission Systems and Equipment for WDM Networking II
SPIE Conference 5247, 7–11 September 2003, Orlando, Florida, USA

This presentation is available on-line at
<http://www.cis.ohio-state.edu/~jain/talks/itcom03.htm>



Overview

- Introduction to PON:
 - ✓ What? How? Where? Why?
- Recent Developments
- Issues
- Challenges

Access: Fiber To The X (FTTx)

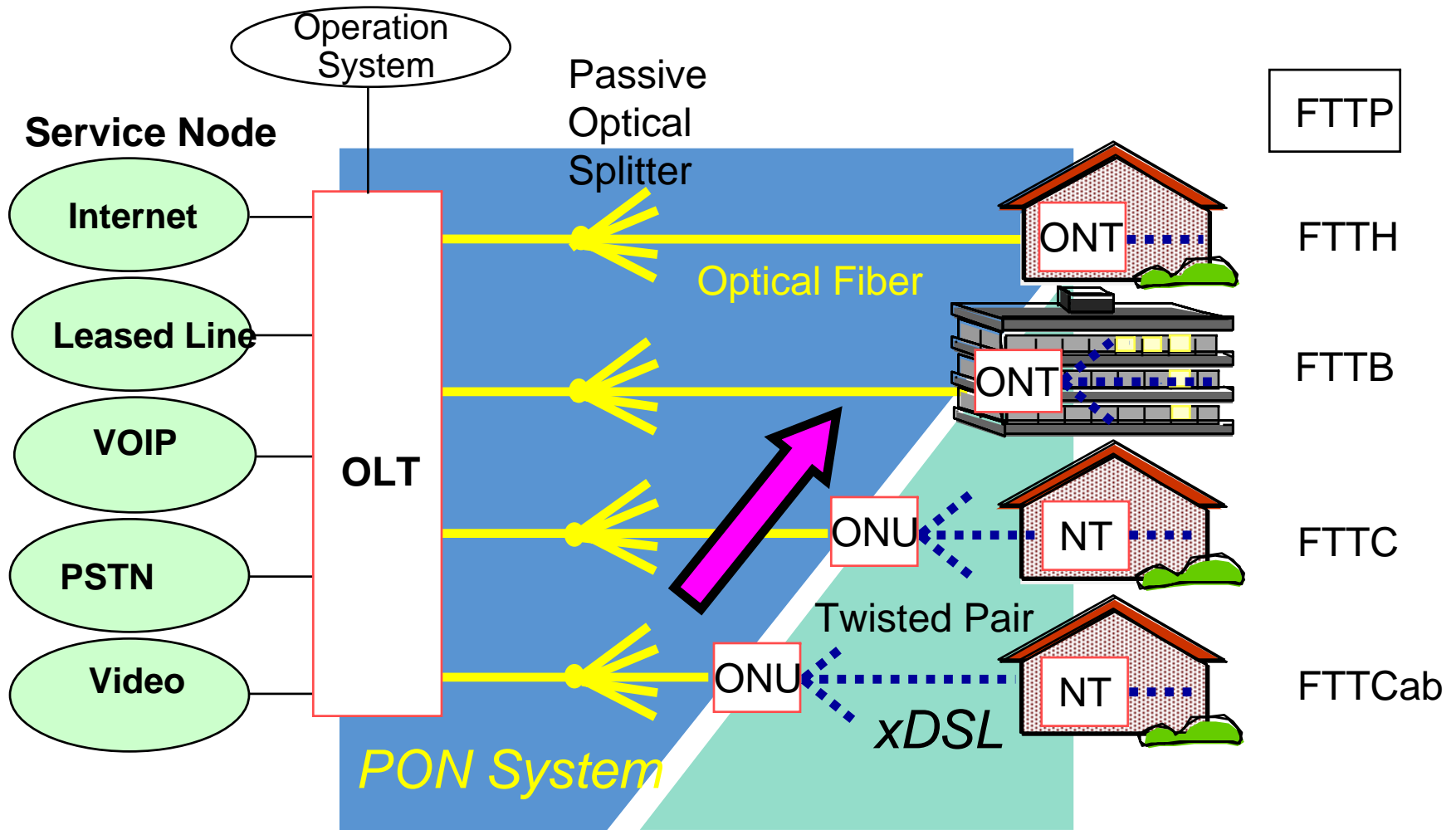

FTTH :Fiber To The Home
 FTTB :Fiber To The Building

FTTC:Fiber To The Curb
 FTTCab :Fiber To The Cabinet



Passive Optical Networks

- A single fiber is used to support multiple customers
- No active equipment in the path \Rightarrow Highly reliable
- Both upstream and downstream traffic on ONE fiber (1490nm down, 1310nm up). OLT assigned time slots upstream.
- Optical Line Terminal (OLT) in central office
- Optical Network Terminal (ONT) on customer premises
Optical Network Unit (ONU) at intermediate points w xDSL

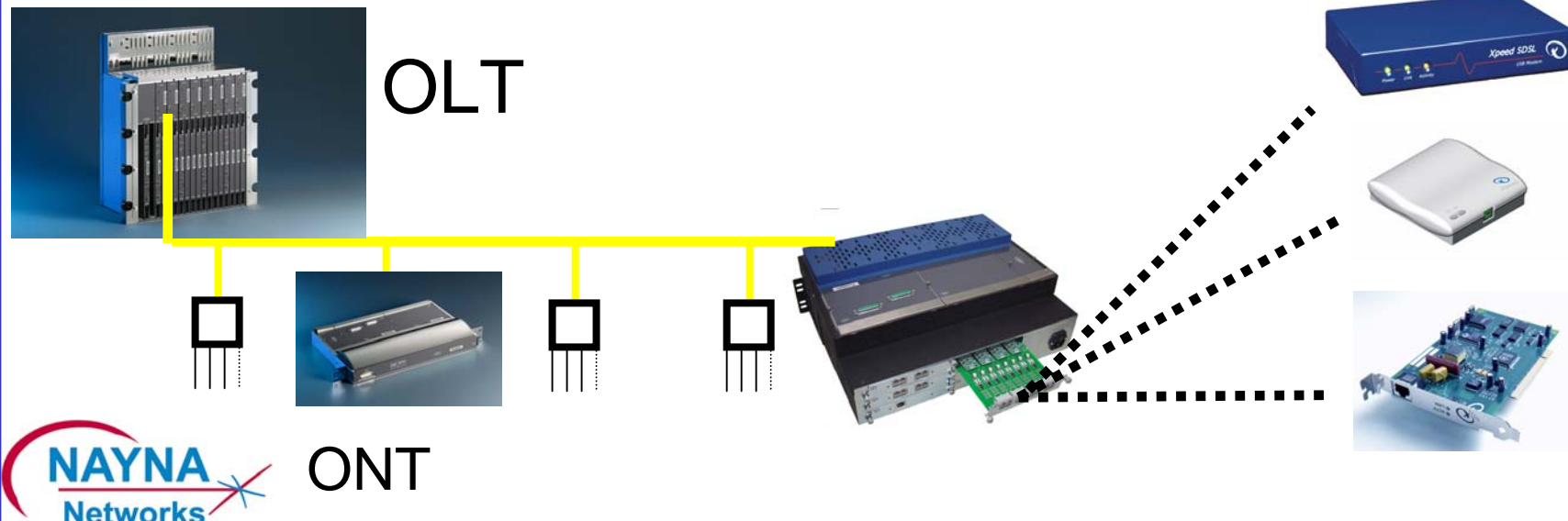

Broadcast Video Over PON

➤ Analog or Digital Video on 1550 nm

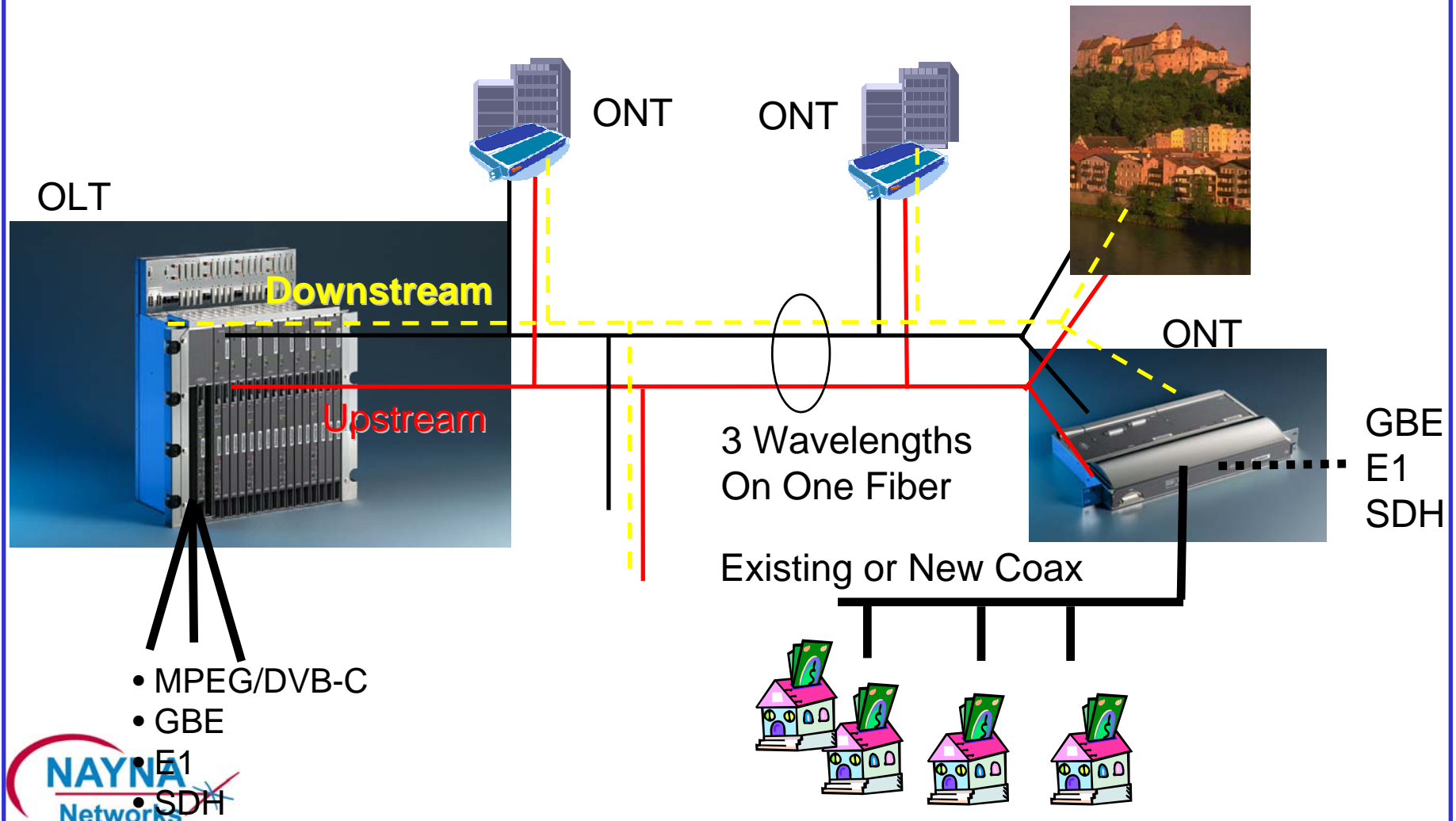

PON Applications

1. FTTP

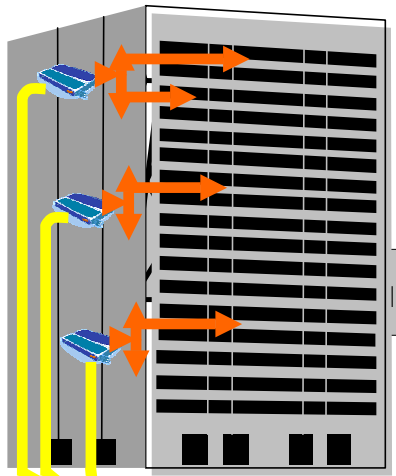

2. Cellular Backhaul

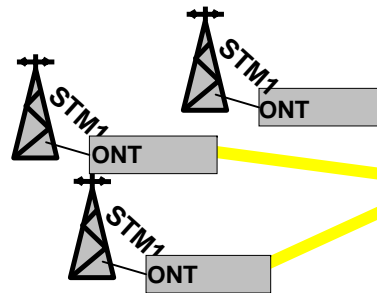

Comm



Remote DSLAM/DLC

3. CATV MSO

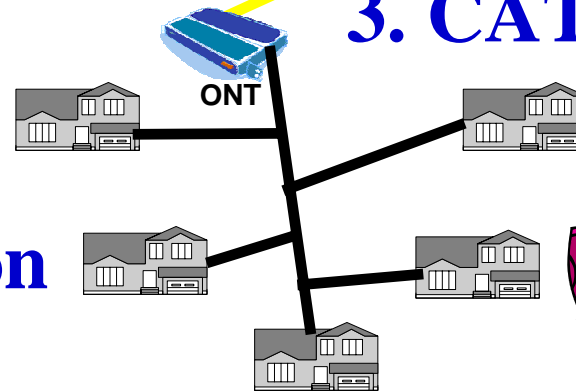

4. DSLAM Aggregation



Why PONs?

- **Reduced OpEx:** Passive network
 - ✓ High reliability \Rightarrow Reduced truck rolls
 - ✓ Reduced power expenses
 - ✓ Shorter installation times
- **Reduced CapEx:**
 - ✓ 16 -128 customers per fiber
 - ✓ 1 Fiber +N transceivers vs N Fibers + 2N transceivers
- **Increased Revenue Opportunities:**
Multi-service: Data, E1/T1, Voice, Video
- **Scalable:**
 - ✓ CO Equipment Shared \Rightarrow New customers can be added easily as the network grows
 - ✓ Bandwidth is Shared \Rightarrow Existing Customer bandwidth can be changed on demand

Types of PONs

- **APON:** Initial name for ATM based PON spec.
Designed by Full Service Access Network (FSAN) group
- **BPON:** Broadband PON standard specified in ITU G.983.1 thru G.983.7 = APON renamed
 - ✓ 155 or 622 Mbps downstream, 155 upstream
- **EPON:** Ethernet based PON draft being designed by IEEE 802.3ah.
 - ✓ 1000 Mbps down and 1000 Mbps up.
- **GPON:** Gigabit PON standard specified in ITU G.984.1 and G.984.2
 - ✓ 1244 and 2488 Mbps Down, 155/622/1244/2488 up

Telecom Developments

Bad News:

- Telecom companies have had their fair share of economic downturn
- Number of employees has gone down
- Carriers no longer can support active electronics in the field

Good News:

- Telecom winter is over
Spring is finally here
- Component prices are going down
- Metro/Access Ethernet is taking off
PON provides an ideal solution

PON Developments

- GPON recommendations G.984.x are out.
EPON draft is progressing fast.
- FCC removed fibers from unbundling
- SBC, Verizon, Bellsouth issued an RFP in USA
 - ✓ Carriers in Japan and Europe are seriously investigating FTTH
 - ✓ Most big telecom vendors in US were caught off-guard with no PON equipment
- Most action in Access than in Core or Metro
- Venture Financing for PON is up
 - ✓ Several PON companies received funding this year
- Over 800 Communities in USA are investigating fibers to home using PONs
- Fiber-to-the-Home Installations Expected to Reach Approximately One Million by 2004 [FTTH Council]



Conclusion: 2004 will be the year of PON



Technology Issues

➤ EPON vs BPON and GPON

- ✓ Ethernet vs ATM
- ✓ Future vs Present
- ✓ Low cost due to high-volume

Recommendation: BPON for existing environment
Standard-based EPON for new installations

➤ 155 vs 622 vs 1250 Mbps

- ✓ Four 155 PONs shared by 32 subscribers each vs
One 622 PON shared by 32 subscribers
High-speed justified only if IP video or high-speed data services
- ✓ Current DSL offerings are in Kilobits to a few Mbps
- ✓ Technology alone does not make deployment
- ✓ Business case will emerge only with CLECs

Service Issues

- **Services:** Triple-Play – Voice, Video, Data
 - ✓ Quad-Play – Voice, Video, Data, and TDM (T1/E1)
 - ✓ T1/E1 is important to maintain legacy services
Leased lines are big revenue for ILECs
 - ✓ Recent VOIP protocols help in providing voice services but not so much in TDM
 - ✓ Need enhanced QoS
- **VOIP Service vs POTS:**
 - ✓ In-house equipment is assumed to be POT in both cases
 - ✓ Signaling/ringing, power source/battery backup
Centralized with copper, localized with fiber
Easier with older technology but extra cost with fiber
 - ✓ VOIP offers numerous new features including multiple phone numbers per household. Significant impact on social behavior

Summary

- 2004 will be the year of PONs
- PONs reduce OpEx and CapEx for carriers and increase carrier revenue opportunities with value-added services
- BPON for today and EPON for today and onwards
- Multi-service support in next-generation EPON products is a key differentiator.
- EPON products need to offer quad-play: Data, voice, video, and TDM to be effective

PON Organizations

- FSAN, fsan.mblast.com/default.asp
- ITU-T, www.itu.int
- IEEE 802.3ah, www.ieee802.org/3/efm/
- PON Forum, www.ponforum.org
- FTTH Council, www.ftthcouncil.org
- Ethernet in the First Mile Alliance (EFMA)
www.efmalliance.org