

Voice over IP: Issues and Challenges

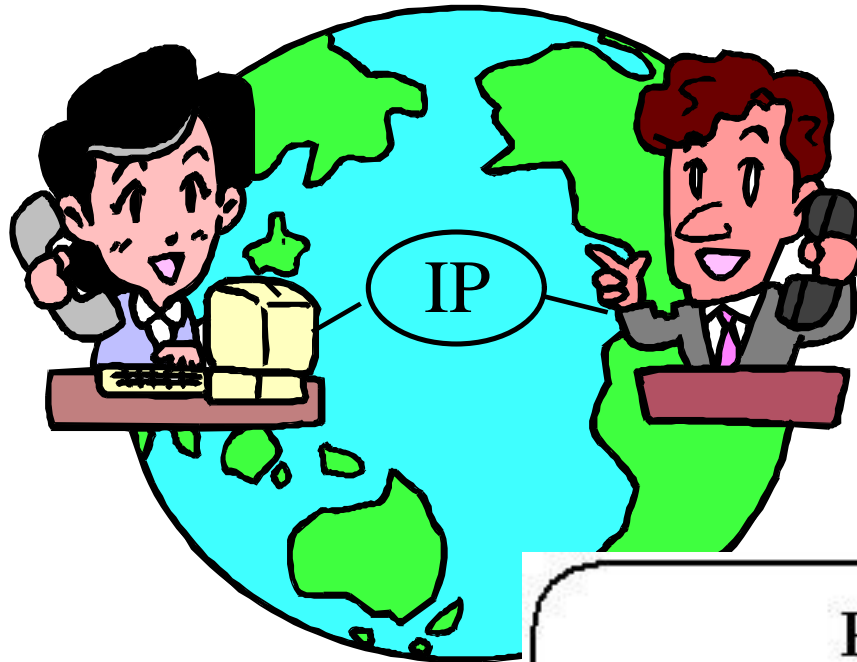

Raj Jain

Raj Jain is now at
Washington University in Saint Louis
Jain@cse.wustl.edu
<http://www.cse.wustl.edu/~jain/>



- ❑ Voice over IP: Why?
- ❑ Sample Products and Services
- ❑ 13 Technical Issues
- ❑ 4 Other Issues
- ❑ Protocols
- ❑ H.323 Standard

Market

- ❑ International VOIP calls could cost 1/5th of normal rates ⇒ Big share of \$18B US to foreign calls. \$15B within Europe.
- ❑ 500,000 IP telephony users at the end of 1995.
- ❑ 15% of all voice calls on IP/Internet by 2000
⇒ 10M users and \$500M in VOIP product sales in 1999 [IDC]
- ❑ US VOIP service will grow from \$30M in 1998 to \$2B in 2004 [Forester Research]
\$2B in 2001 and \$16B by 2004 [Frost & Sullivan]

Scenario 1: PC to PC

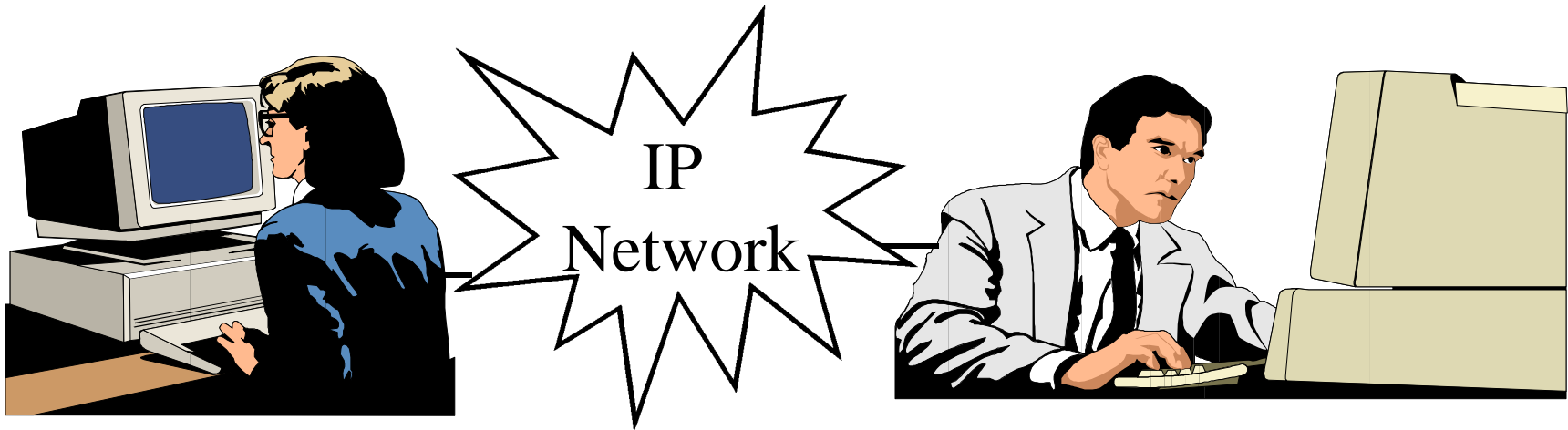

- ❑ Need a PC with sound card
- ❑ IP Telephony software: Cuseeme, Internet Phone, ...
- ❑ Video optional

Scenario 2: PC to Phone

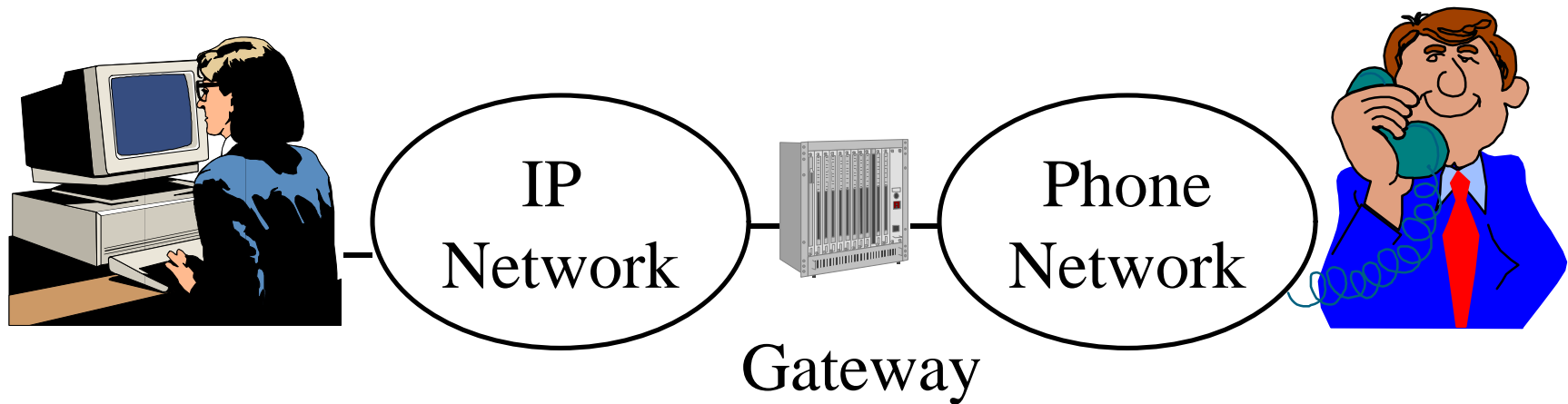

- ❑ Need a gateway that connects IP network to phone network (Router to PBX)

Scenario 3: Phone to Phone

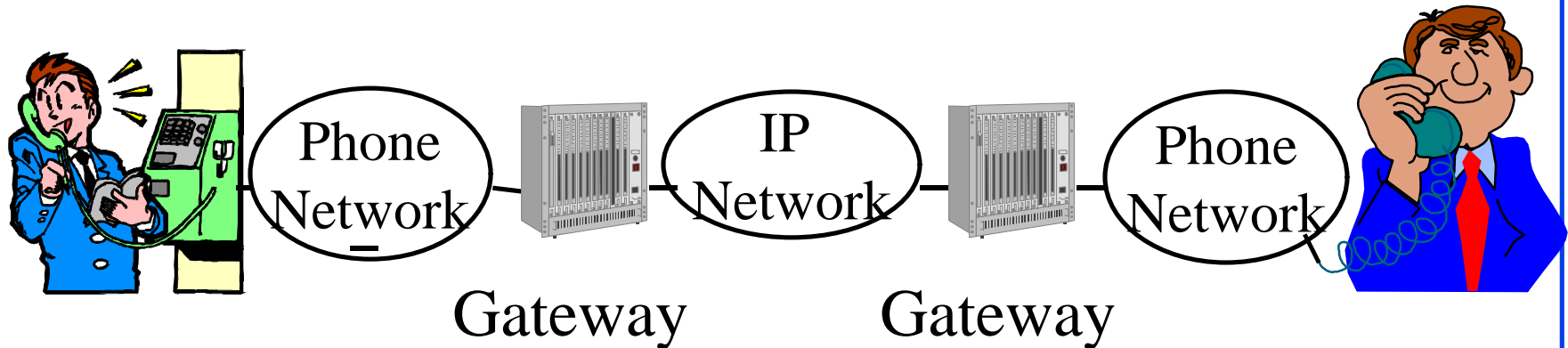

- ❑ Need more gateways that connect IP network to phone networks
- ❑ The IP network could be dedicated intra-net or the Internet.
- ❑ The phone networks could be intra-company PBXs or the carrier switches

Advantages

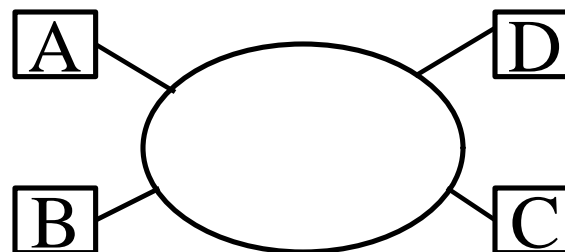
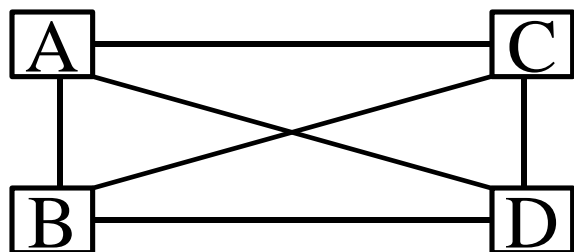

- ❑ Private voice networks require $n(n-1)$ access links. Private data networks require only n access links.
- ❑ Voice has per-minute distance sensitive charge
Data has flat time-insensitive distance-insensitive charge
- ❑ Easy alternate routing \Rightarrow More reliability
- ❑ No 64kbps bandwidth limitation
 \Rightarrow Easy to provide high-fidelity voice

Applications

- ❑ Any voice communication where PC is already used:
 - Document conferencing
 - Helpdesk access
 - On-line order placement
- ❑ International callbacks
(many operators use voice over frame relay)
- ❑ Intranet telephony
- ❑ Internet fax

Sample Products

- ❑ VocalTec Internet Phone: PC to PC.
- ❑ Microsoft NetMeeting: PC to PC. Free.
- ❑ Internet PhoneJACK: ISA card to connect a standard phone to PC. Works with NetMeeting, InternetPhone etc. Provides compression.
- ❑ Internet LineJACK: Single-line gateway.
- ❑ Micom V/IP Family:
 - Analog and digital voice interface cards
 - PC and/or gateway

Products (Cont)

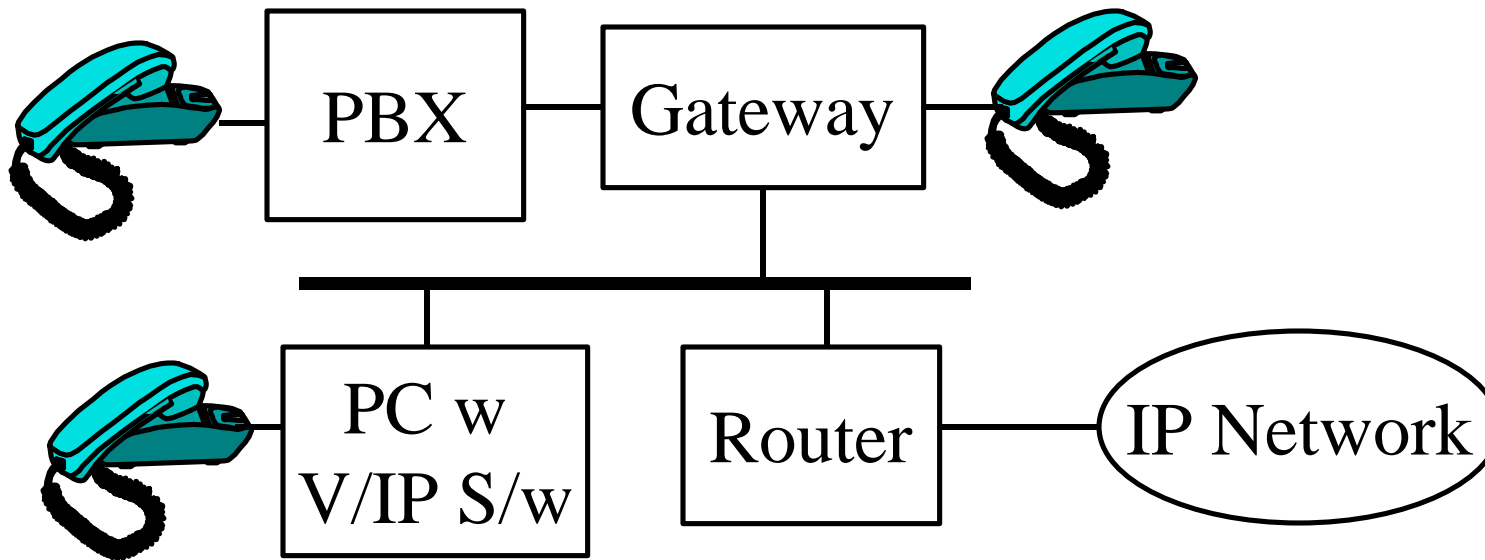

○ Features:

- Compression
- Phone number to IP address translation.
- Supports RSVP.
- Limits number of calls.

Products (Cont)

- VocalTec Internet Telephony Gateway:
 - Similar to Micom V/IP
 - Interactive voice response system for problem reporting
 - Allows WWW plug in
 - Can monitor other gateways and use alternate routes including PSTN
 - Sold to Telecom Finland. New Zealand Telecom.
- Lucent's Internet Telephony Server: Gateway|
Lucent PathStar Access Server

Products (Cont)

- ❑ CISCO 2600 Routers: Voice interface cards (VICs)
Reduces one hop.
- ❑ Baynetworks, 3COM, and other router vendors have announced product plans

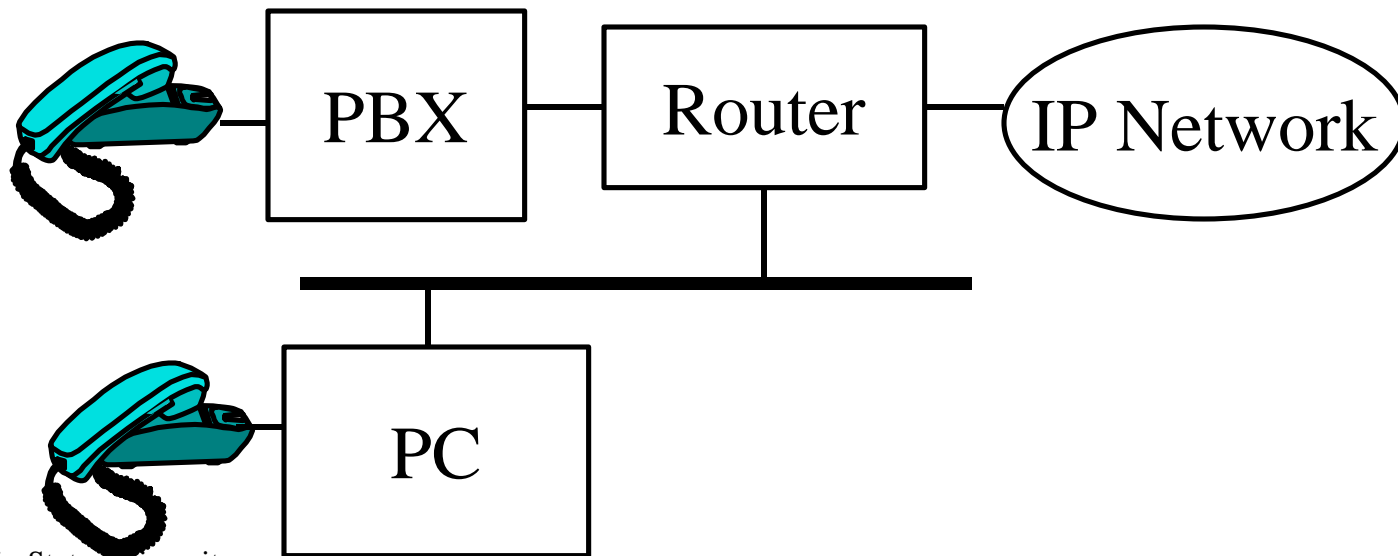

Sample Services

- ❑ IDT Corporation offers Net2Phone, Carrier2Phone, Phone2Phone services.
- ❑ Global Exchange Carrier offers international calls using VocalTec InternetPhone s/w and gateways
- ❑ Quest offers 7.5¢/min VOIP Q.talk service in 16 cities.
- ❑ ITXC provides infrastructure and management to 'Internet Telephone Service Providers (ITSPs)'
- ❑ America On-line offers 9¢/min service.
- ❑ AT&T announced 7.5¢/min VOIP trials in 9 US cities.

Services (Cont)

- ❑ Other trials: USA Global link, Delta 3, WorldCom, MCI, U.S. West, Bell Atlantic, Sprint, AT&T/Japan, KDD/Japan, Dacom/Korea, Deutsche Telekom in Germany, France Telecom, Telecom Finland, and New Zealand Telecom.
- ❑ Level 3 is building a nation wide IP network for telephony.
- ❑ Bell Canada has formed 'Emergis' division.
- ❑ Bellcore has formed 'Soliant Internet Systems' unit
- ❑ Bell Labs has formed 'Elemedia' division

Technical Issues

1. Large Delay

- Normal Phone: 10 ms/kmile \Rightarrow 30 ms coast-to-coast
- G.729: 10 ms to serialize the frame + 5 ms look ahead + 10 ms computation = 25 ms one way algorithmic delay
- G.723.1 = 100 ms one-way algorithmic delay
- Jitter buffer = 40-60 ms
- Poor implementations \Rightarrow 400 ms in the PC
- In a survey, 77% users found delay unacceptable.

Technical Issues (Cont)

2. Delay Jitter: Need priority for voice packets.
Shorter packets? IP precedence (TOS) field.
3. Frame length: 9 kB at 64 kbps = 1.125 s
Smaller MTU \Rightarrow Fragment large packets
4. Lost Packets: Replace lost packets by silence,
extrapolate previous waveform
5. Echo cancellation: 2-wire to 4-wire.
Some FR and IP systems include echo suppressors.

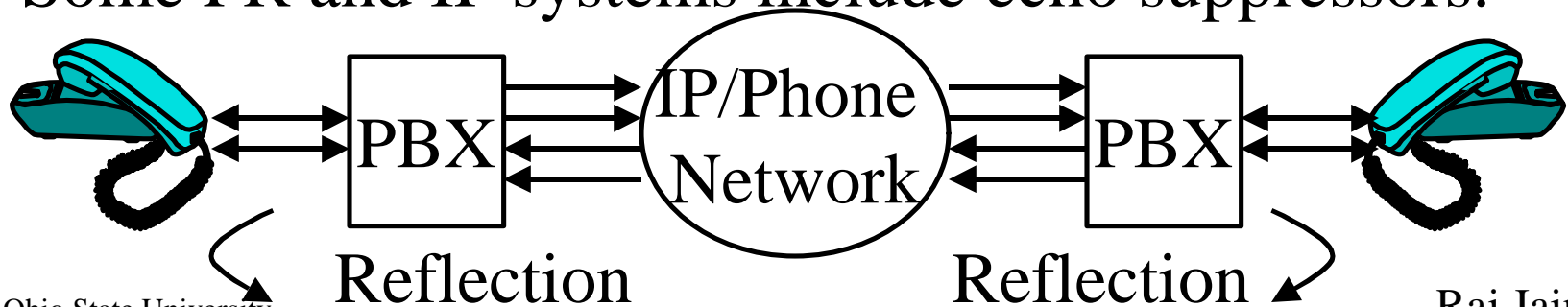

Technical Issues (Cont)

6. Silence suppression
7. Address translation: Phone # to IP. Directory servers.
8. Telephony signaling: Different PBXs may use different signaling methods.
9. Bandwidth Reservations: Need RSVP.
10. Multiplexing: Subchannel multiplexing
⇒ Multiple voice calls in one packet.
11. Security: Firewalls may not allow incoming IP traffic
12. Insecurity of internet
13. Voice compression: Load reduction

Other Issues

1. Per-minute distance-sensitive charge vs flat time-insensitive distance-insensitive charge
2. Video requires a bulk of bits but costs little. Voice is expensive. On IP, bits are bits.
3. National regulations and government monopolies
⇒ Many countries forbid voice over IP
In Hungary, Portugal, etc., it is illegal to access a web site with VOIP s/w. In USA, Association of Telecommunications Carriers (ACTA) petitioned FCC to levy universal access charges in ISPs
4. Modem traffic can't get more than 2400 bps.

Compression Standards

- ❑ G.711: 64 kbps Pulse Code Modulation (PCM)
- ❑ G.721:
 - 32 kbps Adaptive Differential PCM (ADPCM).
 - Difference between actual and predicted sample.
 - Used on international circuits
- ❑ G.728: 16 kbps Code Excited Linear Prediction (CELP).
- ❑ G.729: 8 kbps Conjugate-Structure Algebraic Code Excited Linear Prediction (CS-ACELP).

Compression (Cont)

- G.729A:
 - A reduced complexity version in Annex A of G.729.
 - Supported by AT&T, Lucent, NTT.
 - Used in simultaneous voice and data (SVD) modems.
 - Used in Voice over Frame Relay (VFRADs).
 - 4 kbps with proprietary silence suppression.

Compression (Cont)

- G.723.1: Dual rates (5.3 and 6.3 kbps).
 - Packet loss tolerant.
 - Silence suppression option.
 - Recommended by International Multimedia Teleconferencing Consortium (IMTC)'s VOIP forum as default for H.323.
 - Supported by Microsoft, Intel.
 - Mean opinion score (MOS) of 3.8.
4.0 = Toll quality.

Protocols

- ❑ RSVP: Resource Reservation protocol [RFC 2205]
- ❑ RTP: Real-time Transport Protocol.
Sequencing, timestamp, payload identification, and delivery monitoring. [RFC 1889]
- ❑ RTCP: RTP Control Protocol. Provides delivery feedback.
- ❑ RTSP: Real-time Streaming Protocol. Allows controlling streaming audio/video. [RFC 2326]
- ❑ SIP: Session Initiation Protocol [IETF mmusic]
- ❑ SDP: Session Description Protocol [RFC 2327]

Protocols (Cont)

- ❑ SAP: Session Announcement Protocol [IETF mmusic]
- ❑ SCCP: Simple Conference Control Protocol [IETF mmusic]
- ❑ VPIM: Voice Profile for Internet Mail [RFC 1911]. Voice messages in email. MIME profile.
- ❑ SCTP: Simple Computer Telephony Protocol. Like SMTP for mail. [www.phonezone.com]
- ❑ 802.1p: Priority over LANs
- ❑ 802.1Q: Virtual LANs

Protocols (Cont)

- ❑ S.100: Standard application programming interface for computer telephony.
 - Endorsed by the Enterprise Computer Telephony Forum.
 - Will allow applications from different vendors to share the telephony server resources for switching, routing, and media processing.
- ❑ SCbus: High-speed TDM bus for computer telephony.
 - Endorsed by ANSI.
 - Telephony products from Micom, VocalTec, IDT are all based on SCbus.

Protocols (Cont)

- ❑ Internet Fax Routing standard: Allows routing communication among fax servers.
- ❑ H.323 Internet telephony (video conferencing) standard

Protocols (Cont)

- ❑ IPv6: 4-bit priority, 24-bit flow label
- ❑ IP over ATM: MPOA allows QoS.
- ❑ MPLS: Multiprotocol Label Switching. Will support QoS. [IETF mpls]
- ❑ ST-II: Stream Protocol V2. Connection oriented IP. IPv5. Provides resource reservations. [RFC 1819]
- ❑ Integrated Services: Guaranteed (CBR) and controlled-load (nrt-VBR) services. [RFC 2211+2212]
- ❑ Multicasting: IGMP [RFC 2236]
- ❑ Multicast Routing: MOSPF, DVMRP, PIM

Telephony/Conferencing Systems

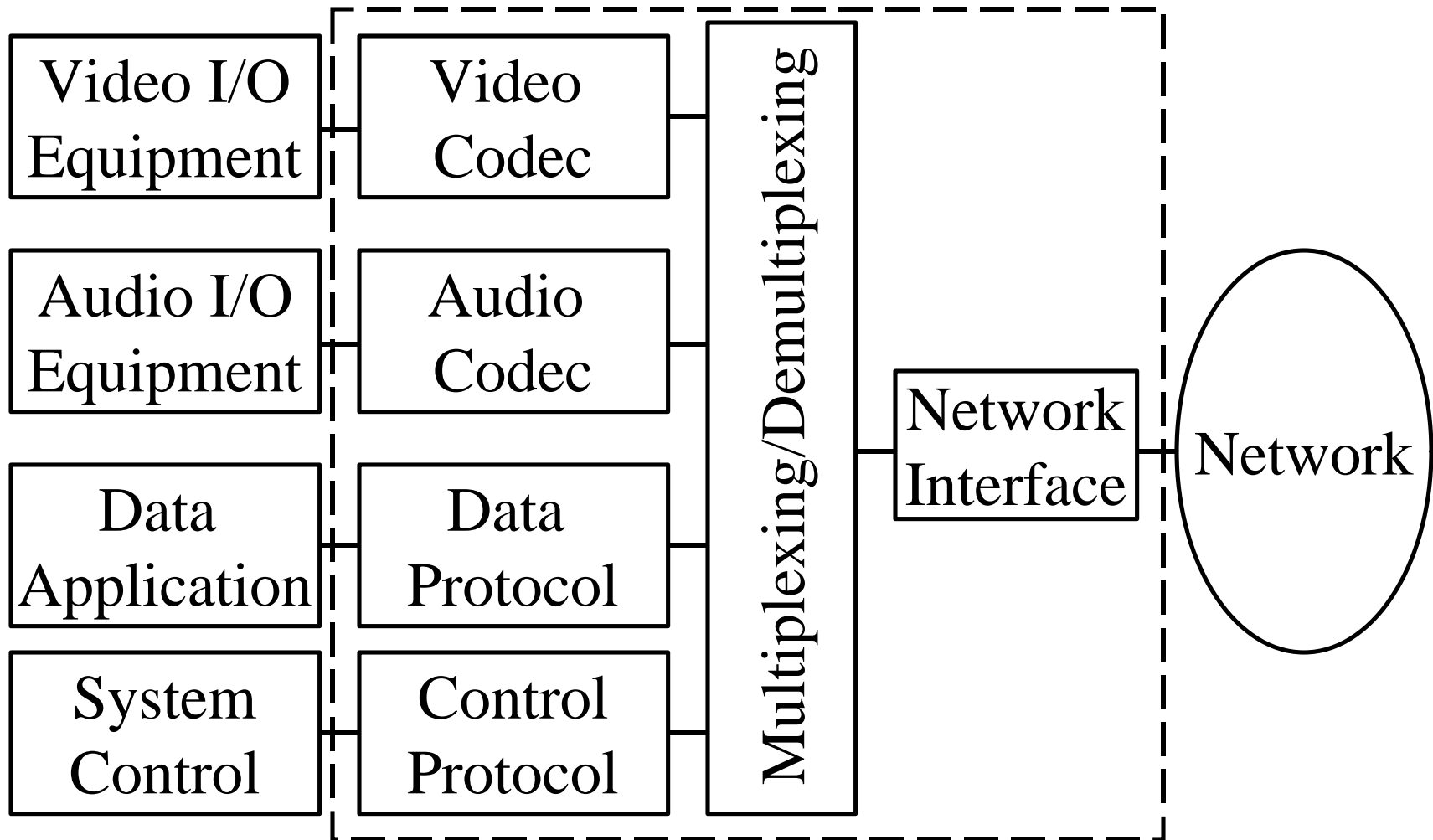

Conferencing Standards

Network	ISDN	ATM	PSTN	LAN	POTs
Conf. Std.	H.320	H.321	H.322	H.323 V1/V2	H.324
Year	1990	1995	1995	1996/1998	1996
Audio Codec	G.711, G.722, G.728	G.711, G.722, G.728	G.711, G.722, G.728	G.711, G.722, G.723.1, G.728, G.729	G.723.1, G.729
Audio Rates kbps	64, 48-64	64, 48-64, 16	64, 48-64, 16	64, 48-64, 16, 8, 5.3/6.3	8, 5.3/6.3
Video Codec	H.261	H.261, H.263	H.261, H.263	H.261 H.263	H.261 H.263
Data Sharing	T.120	T.120	T.120	T.120	T.120
Control	H.230, H.242	H.242	H.242, H.230	H.245	H.245
Multiplexing	H.221	H.221	H.221	H.225.0	H.223
Signaling	Q.931	Q.931	Q.931	Q.931	-

H.323 Protocols

- ❑ Multimedia over LANs
- ❑ Provides component descriptions, signaling procedures, call control, system control, audio/video codecs, data protocols

Video	Audio	Control and Management			Data	
H.261 H.263	G.711, G.722, G.723.1, G.728, G.729	RTCP	H.225.0 RAS	H.225.0 Signaling	H.245 Control	T.124
RTP			X.224 Class 0			T.125
UDP		TCP			T.123	
Network (IP)						
Datalink (IEEE 802.3)						

H.323 Components

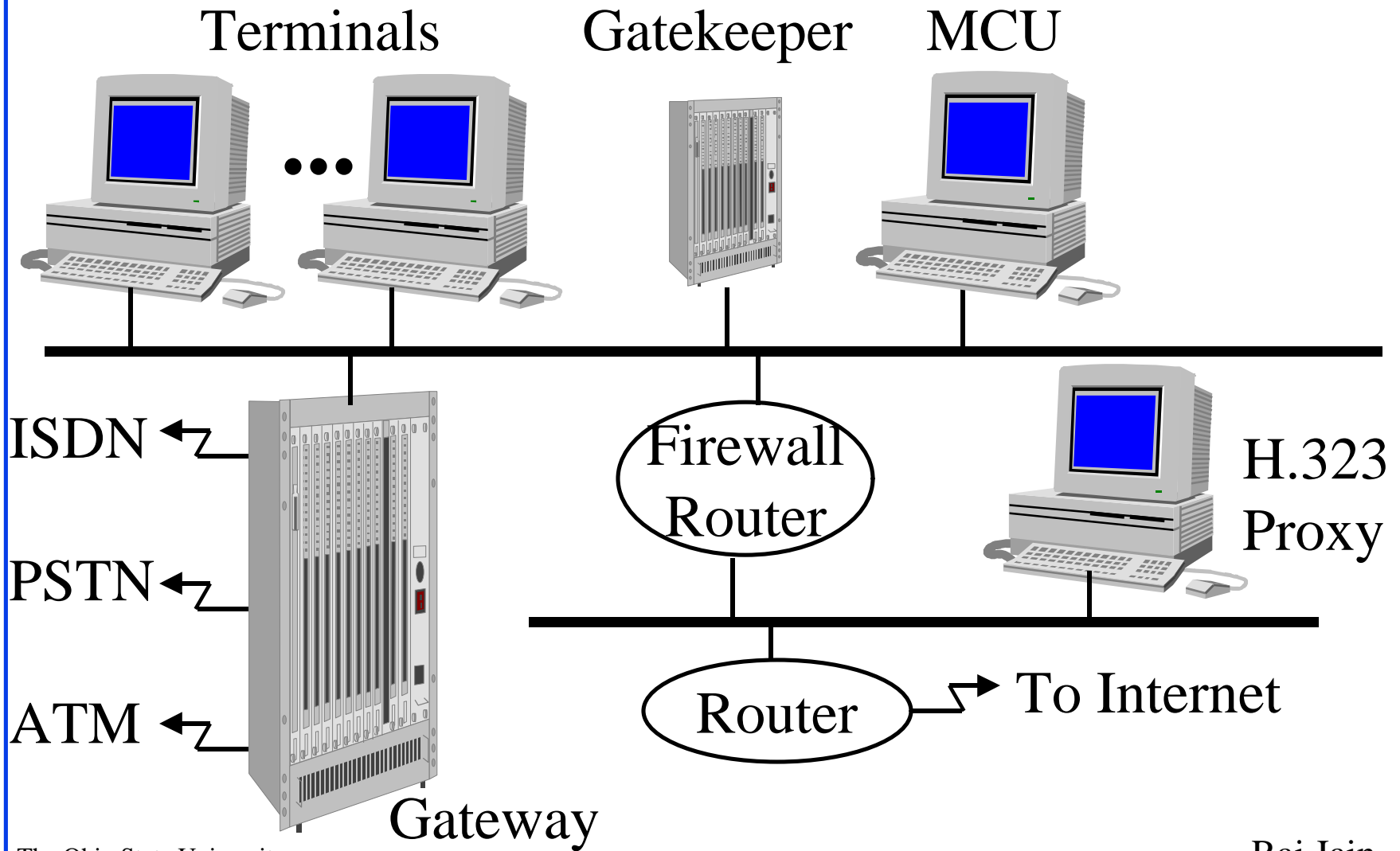

H.323 Terminals

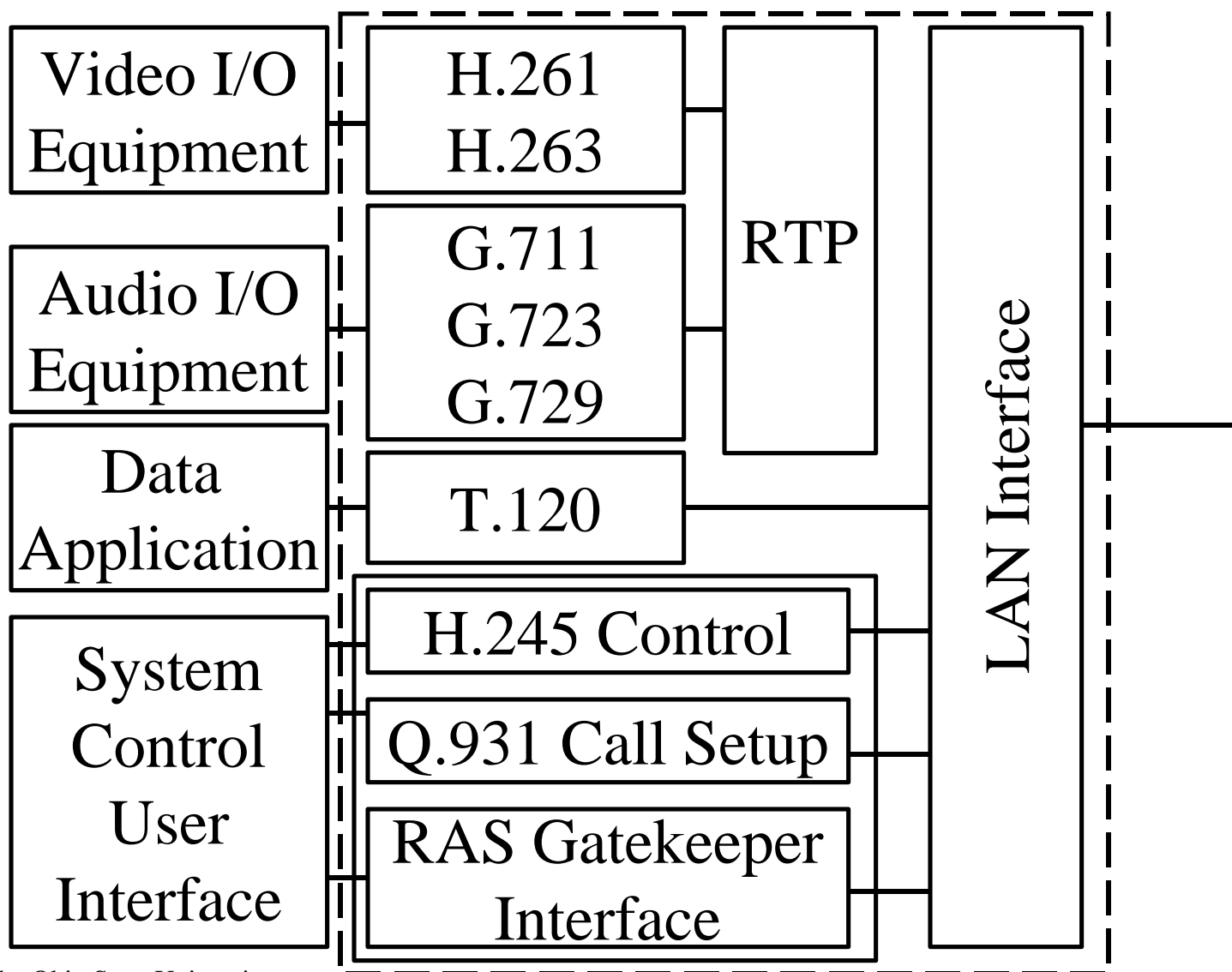

H.323 Terminals

- ❑ Client end points. PCs.
- ❑ H.245 to negotiate channel usage and capabilities.
- ❑ Q.931 for call signaling and call setup.
- ❑ Registration/Admission/Status (RAS) protocol to communicate with gatekeepers.
- ❑ RTP/RTCP for sequencing audio and video packets.

H.323 Gateways

- ❑ Provide translation between H.323 and other terminal types (PSTN, ISDN, H.324)
- ❑ Not required for communication with H.323 terminals on the same LAN.

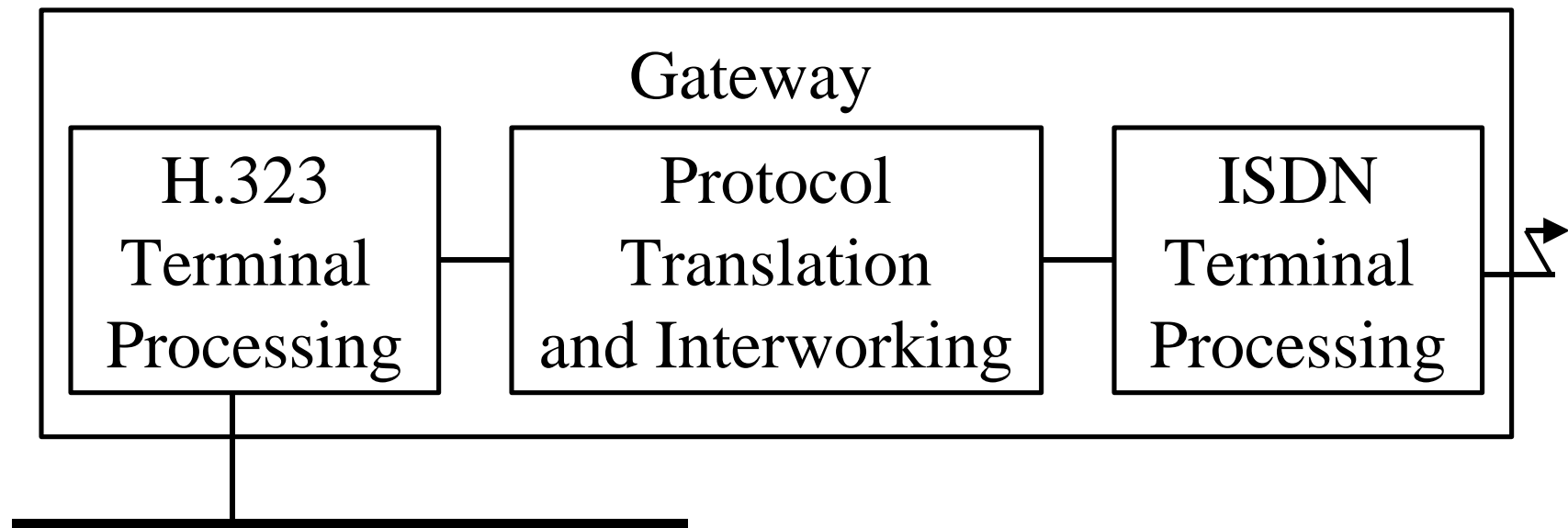

H.323 Gatekeepers

- ❑ Provide call control services to registered end points.
- ❑ One gatekeeper can serve multiple LANs
- ❑ Address translation (LAN-IP)
- ❑ Admission Control: Authorization
- ❑ Bandwidth management
(Limit number of calls on the LAN)
- ❑ Zone Management: Serve all registered users within its zone of control
- ❑ Forward unanswered calls
- ❑ May optionally handle Q.931 call control

H.323 MCUs

- ❑ Multipoint Control Units
- ❑ Support multipoint conferences
- ❑ Multipoint controller (MC) determines common capabilities.
- ❑ Multipoint processor (MP) mixes, switches, processes media streams.
- ❑ MP is optional. Terminals multicast if no MP.

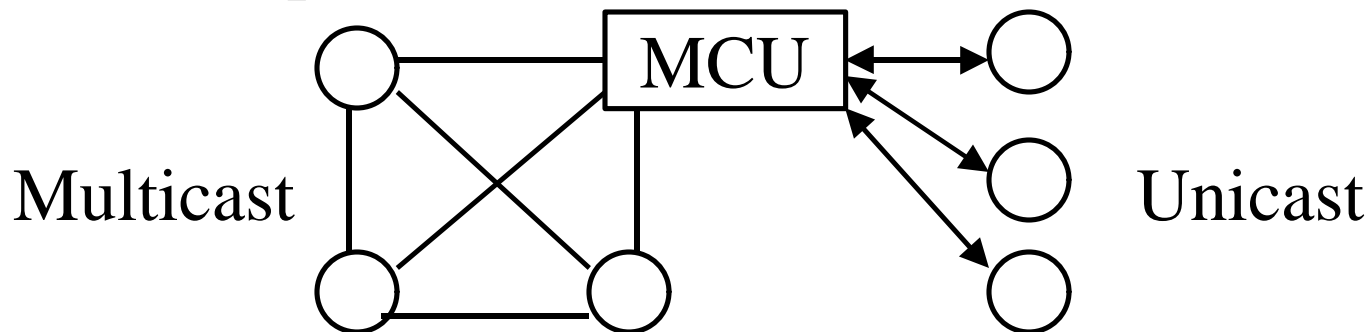

SIP

- ❑ Session Initiation Protocol
- ❑ Allows locating a callee at different locations
- ❑ Callee registers different locations with SIP Server
- ❑ Servers can also use finger, rwhois, ldap to find a callee
- ❑ Messages: Ack, Bye, Invite, Register, Redirection, ...

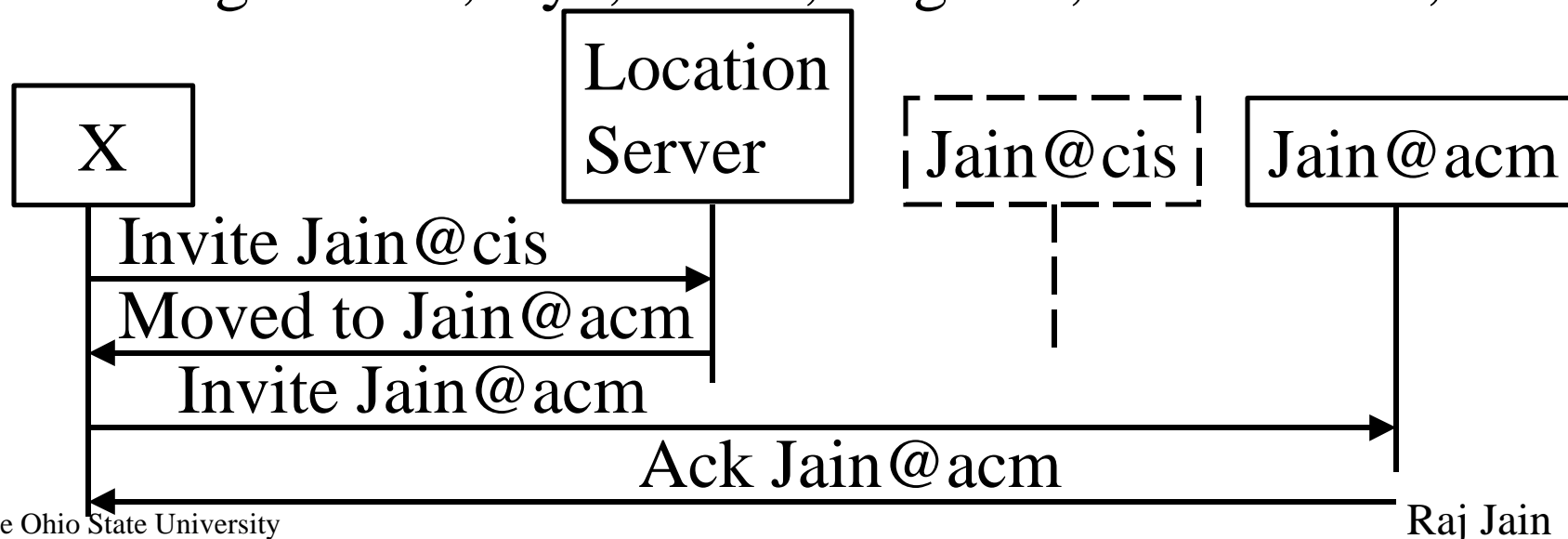

Summary

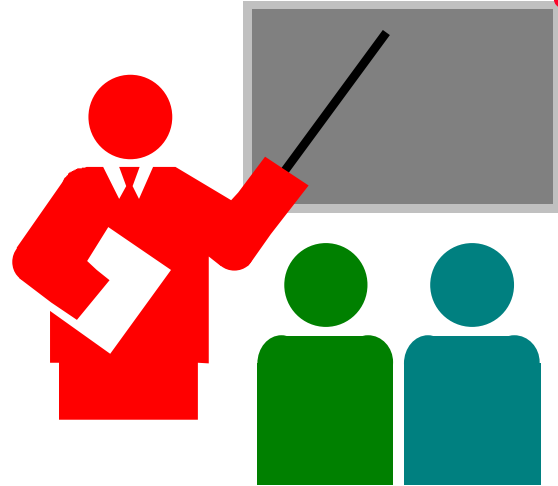

- ❑ Voice over IP products and services are being rolled out
- ❑ Ideal for computer-based communications
- ❑ IP needs QoS for acceptable quality
- ❑ A number of working group at IETF are working on it
- ❑ H.323 provides interoperability

Organizations

- ❑ IMTC: International Multimedia Teleconferencing Consortium
- ❑ VOIP: Founded in 1966 by Cisco, Microsoft, VocalTec, 3Com/USR, Dialogic etc. to augment H.323. Folded into IMTC.
- ❑ Enterprise Computer Telephony Forum (ECTF), <http://www.ectf.org>
- ❑ Internet Fax Routing Forum
- ❑ Voice Profile for Internet Mail (VPIM) Work Group of EMA
- ❑ VON Coalition, Inc., <http://www.von.org>

IETF Working Groups

Multimedia:

- ❑ IP Telephony (iptel): RFC 1789 on INETPhone servers. Will develop Gateway attribute distribution protocol and call processing syntax.
- ❑ Internet Fax (fax): Data representation, addressing, and transport of faxes over IP.
- ❑ PSTN and Internet Interworking (pint):
 - Initiation of telephone services from IP hosts.
 - Web users can request call back, fax, fax-back services.
 - Phone users can request web pages (via speech).

IETF (Cont)

- ❑ Audio/Video Transport (avt): Real-time transmission of audio and video over UDP and IP multicast. RTP, RTCP.
- ❑ Multiparty Multimedia Session Control (mmusic): Internet Teleconferencing. SDP, SAP, RTSP, SIP, SCCP.
- ❑ Also several working groups on multicasting and QoS

References

□ See

http://www.cis.ohio-state.edu/~jain/refs/ref_voip.htm
for a detailed list of references.

Thank You!

