

WASHINGTON UNIVERSITY IN ST. LOUIS
School of Engineering and Applied Science
Department of Computer Science and Engineering

Dissertation Examination Committee:

Raj Jain, Chair
Yixin Chen
Viktor Gruev
Chenyang Lu
Paul Min
Yinjie Tang

Next Generation Internet Architecture and Cyber-assisted
Energy Efficiency in Smart Grids of Buildings

by

Jianli Pan

A dissertation presented to the Graduate School of Arts and Sciences
of Washington University in partial fulfillment of the
requirements for the degree of

DOCTOR OF PHILOSOPHY

May 2014

Saint Louis, Missouri

Table of Contents

List of Figures	x
List of Tables	xv
List of Abbreviations	xvi
Acknowledgments	xx
Abstract	xxii
1 Introduction	1
1.1 PART I: Next Generation Internet Architecture	3
1.2 PART II: Cyber-assisted Energy Efficiency in Smart Grids of Buildings	6
1.3 Dissertation Organization	9
PART I: Next Generation Internet Architecture	
2 Review of the Research on Future Internet Architecture	12
2.1 Introduction	12
2.2 Key Research Topics	14
2.3 Research Projects from United States	16
2.3.1 FIA and FIND	16
2.3.2 Global Environment for Network Innovations (GENI)	21
2.4 Research Projects from European Union and Asia	24

2.4.1	European Union	25
2.4.2	Asia	28
2.5	Discussions and Perspectives	30
2.6	Brief Summary	33
3	MILSA Architectural Framework	34
3.1	Introduction	34
3.2	Related Work	36
3.2.1	Proposals for Separation: Host or Network	36
3.2.2	Schemes for Aggregation or Different Conceptual Routing	37
3.2.3	Solutions for Mobility and Multihoming	38
3.2.4	Key BGP Technologies Related to Our Research	38
3.3	New Concepts and Terminologies	38
3.4	Design Principles and Arguments	40
3.4.1	Design Principles	40
3.4.2	Multi-tier Separation	41
3.5	MILSA Model	43
3.6	MILSA Framework Designs	45
3.6.1	ID Locator Split Argument and Design	45
3.6.2	Different IDs and Realms	47
3.6.3	IDs and Locator Structure	47

3.6.4	Three Level Mapping	49
3.6.5	Mobility and Multihoming	50
3.6.6	Realm Hierarchy and Trust Relationship	53
3.7	MILSA Transition Mechanism	54
3.7.1	Non-technical Incentives	54
3.7.2	Technical Discussions	55
3.7.3	Transition Map and Scenarios	59
3.8	MILSA's Answers to the RRG Design Goals	61
3.9	A Novel Multihoming Framework	63
3.9.1	Motivation	63
3.9.2	Related Work	65
3.9.3	Design Principles and Goals	66
3.9.4	Key Concepts and Models	67
3.9.5	3D Multihoming Framework and Related Issues	72
3.9.6	Discussions	75
3.10	Short Summary	76
4	Evaluation and Analysis for Routing Scalability and New Internet Architecture (NIA)	77
4.1	Introduction	77
4.2	Related Work	78
4.2.1	As-level Measurements	78

4.2.2	Schemes for Aggregation or Different Conceptual Routing	79
4.2.3	Work on Scalability and Future Internet Architecture	79
4.2.4	How They Are Related to Our Work	79
4.3	Methodology	80
4.4	Future Internet: Deployment Incentives and Strategies	81
4.4.1	Deployment Incentives	81
4.4.2	Deployment Strategies	82
4.5	Evaluation and Analysis	83
4.5.1	Basic Evaluation: BGP FIB Table and the Prefixes	83
4.5.2	Autonomous System (AS) and Aggregation Ratio (AR)	86
4.5.3	Site Multihoming Evaluation	89
4.5.4	Deployment Factor: Definition and Implications	91
4.5.5	Quantitative Evaluation Using New Metrics	93
4.5.6	Deployment Benefits of Various Strategies	100
4.5.7	Monitoring Deployment by Metrics' Boundary Values	105
4.6	Reasoning to New Internet Architectures	106
4.6.1	Evaluation Results	107
4.6.2	The Balance Issue	107
4.6.3	Short- and Long-term Goals of Future Internet	108
4.6.4	Limitations of the Evaluation	109

4.7	Short Summary	109
PART II: Cyber-assisted Energy Efficiency in Smart Grids of Buildings		
5.	Review of the Research on Energy Efficiency in Buildings and Microgrids using Networking Technologies	110
5.1	Introduction	110
5.2	Intelligent Buildings: Overall Framework	113
5.2.1	Overall Framework	113
5.3	Intelligent Buildings: Key Subsystems	115
5.3.1	Integrated Communication Network and Building Management IT System	115
5.3.2	Energy Management and Grid Interaction	117
5.3.3	Building Automation System (BAS)	121
5.4	Small Residential Buildings: Smart Home	123
5.4.1	Large Office Buildings vs. Residential Buildings	123
5.4.2	Home Automation	124
5.4.3	Home Area Network (HAN)	125
5.4.4	Net-zero Energy Building and Energy Efficiency at Home	126
5.4.5	Smart Thermostat at Home	127
5.5	Convergence of Intelligent and Green Technologies in the Building Environments	127
5.5.1	Definition	128

5.5.2	Energy-efficiency and Sustainability Benefits	128
5.5.3	Key Supporting Technologies for Intelligent and Green Converged Buildings	130
5.6	Key Issues and Trends Discussions	131
5.6.1	Energy Proportionality of the Buildings	131
5.6.2	Human Behavior Factors	132
5.6.3	Networking Convergence and Interaction with the Grids	134
5.6.4	Cloud Computing in Facilitating the Interaction between Consumer-side and Provider-side Grid	134
5.6.5	New Opportunities in a Smart World	136
5.7	Brief Summary	136
6	Energy Consumption Data Evaluation and Analysis for a Networked Green Building Testbed	138
6.1	Introduction	138
6.2	Related Work	139
6.3	Testbed and Methodology	140
6.3.1	Testbed Description and Features	140
6.3.2	Data Source and Analysis Methodology	141
6.4	Evaluation and Analysis	142
6.4.1	Environmental Impacts Analysis	142
6.4.2	Occupancy Impact Analysis	149

6.5	Energy Modeling Discussions	154
6.5.1	Observations Summary	154
6.5.2	Energy Proportional Buildings: A New Concept Derived from Computer Industry	155
6.6	Nine Lessons Learned from the Green Building Testbed	156
6.6.1	Lesson #1	156
6.6.2	Lesson #2	158
6.6.3	Lesson #3	159
6.6.4	Lesson #4	160
6.6.5	Lesson #5	161
6.6.6	Lesson #6	163
6.6.7	Lesson #7	164
6.6.8	Lesson #8	165
6.6.9	Lesson #9	168
6.7	Brief Summary	169
7	Multi-scale Energy Proportionality Using Location-based Networked Control	170
7.1	Introduction	170
7.2	Smart Location-Based Automated Energy Control Framework	172
7.2.1	Overall Structure	172
7.2.2	Energy Monitoring	173

7.2.3	Smart Mobile Devices as Remote Controls	174
7.2.4	Multi-source Energy-saving Policies Hierarchy	175
7.2.5	Mobile Device Location-Based Automatic Control	176
7.2.6	Cloud Computing and Storage	177
7.3	Prototype System, Experimental Results, and Multi-scale Energy Proportionality	178
7.3.1	Prototype Description	178
7.3.2	Experiments and Results	180
7.3.3	Multi-scale Energy Proportionality	183
7.4	Brief Summary	184
8	Summary	185
	References	188
	Vita	203

List of Figures

Figure 1.1:	Two major research focuses and their relationship	3
Figure 1.2	PART I research tasks and contributions	4
Figure 1.3	PART II research tasks and contributions	8
Figure 2.1	The new “narrow waist” of NDN (right) compared with current Internet (left)	17
Figure 2.2	MobilityFirst architecture	19
Figure 2.3	NEBULA architecture component and their interactions	20
Figure 2.4	XIA components and interactions	21
Figure 2.5	FIRE clustering of projects	27
Figure 3.1	Multi-level separation and the interfaces and relationships	41
Figure 3.2	MILSA's 3D model	44
Figure 3.3	A first-step MILSA example structure (two level hierarchy)	45
Figure 3.4	ID locator split in the protocol stack	46
Figure 3.5	IDs in Locator, Host, and User Realms	47
Figure 3.6	A example of fitting the MID into 128 bits code	49
Figure 3.7	Name resolutions and mappings	50
Figure 3.8	Simple many-cast example	52
Figure 3.9	realm hierarchy and trust relationship: an example	53

Figure 3.10	A legacy host talks to a legacy host	57
Figure 3.11	A legacy host (without MBR) talks to a legacy host (with MBR)	57
Figure 3.12	A MILSA host talks to a MILSA host	58
Figure 3.13	A MILSA host talks to a legacy host	59
Figure 3.14	MILSA transition map	60
Figure 3.15	MILSA transition scenarios	60
Figure 3.16	Example of flexible and extensible slice structure (Slice 0, 1, and 2)	69
Figure 3.17	A simple host multihoming example	70
Figure 3.18	A simple user multihoming example	71
Figure 3.19	An example illustration of the 3D multihoming framework	72
Figure 3.20	Hybrid push/pull/caching mapping delivery	74
Figure 4.1	AS and Prefix Distribution	85
Figure 4.2	Cumulative ASs count (# of ASs with aggregation degree larger than the value of the X-axis)	86
Figure 4.3	Top-N ASs and their cumulative aggregation degree (ASs are sorted by their prefixes announced)	87
Figure 4.4	Top-N ASs and their cumulative prefixes announced (ASs sorted by their prefixes announced)	88
Figure 4.5	Stub multihoming: Number of ASs and Prefixes	90
Figure 4.6	Multihoming trends	91
Figure 4.7	Top 15 ASs announcing the most prefixes, a sample example	93

Figure 4.8	Cumulative PC distribution in the whole AS space (ASs sorted in increasing order of PCs)	94
Figure 4.9	A one-hour sample of BGP updates of August 2009	95
Figure 4.10	Aggregation Ratio (AR) examples	96
Figure 4.11	AR distribution in the whole AS space (ASs are sorted in decreasing order by PCs)	96
Figure 4.12	Number of ASs and Prefixes announced in groups 1, 2, and 3	97
Figure 4.13	APAR distribution in the whole AS space (ASs are sorted in decreasing order by APARs)	98
Figure 4.14	RPAR distribution in the whole AS space (ASs are sorted in decreasing order by APAR)	100
Figure 4.15	Prefix decrease for the three strategies with deployment speeds of 10%, 20%, and 30% per month.	101
Figure 4.16	Cumulative PC improvements with the three deployment strategies	103
Figure 4.17	Cumulative AR improvements of the 3 strategies (Note: 1. ASs are sorted in decreasing order by their PCs; 2. Assume a first-step of 50% reduction of the unaggregated prefixes)	104
Figure 5.1	Intelligent buildings and related subsystems	114
Figure 5.2	Integrated communication system of intelligent buildings	116
Figure 5.3	The relationship among energy generation, storage, consumption, and external grid in intelligent building and microgrid level	119
Figure 6.1	Testbed metering network and online real-time monitoring	141
Figure 6.2	Total electrical energy consumption traces of 168 hours (7 days)	142

Figure 6.3	Heating consumption traces of 168 hours (7 days)	143
Figure 6.4	Total electrical energy consumption with temperature	144
Figure 6.5	Heating energy consumption with temperature	144
Figure 6.6	Correlations between electrical energy (Z), temperature (X), and humidity (Y)	145
Figure 6.7	Correlations between heating energy (H), temperature (X) and humidity (Y)	146
Figure 6.8	Daily heating and cooling energy during the specified period	147
Figure 6.9	Daily electrical energy consumption	147
Figure 6.10	Daily electrical energy consumption MPR regression plane	149
Figure 6.11	Daily heating energy consumption MPR regression	149
Figure 6.12	The comparison of electrical energy consumption averaged in 24 hours for office hours, after hours, and weekends	150
Figure 6.13	The comparison of heating energy consumption averaged in 24 hours for office hours, after hours, and weekends	151
Figure 6.14	Correlation comparisons among office hours, after hours, and weekends. The correlations are $\text{Corr}(XZ)$, $\text{Corr}(HX)$, and $\text{Corr}(CX)$ from left to right respectively. (Z: electrical energy, H: heating, C: Cooling, X: temperature, Y: humidity)	152
Figure 6.15	Summer and Fall daily electrical energy consumption comparison	152
Figure 6.16	Summer and Fall daily heating and cooling energy consumption comparison	153
Figure 6.17	The daily energy consumption comparison between Summer and	

	Fall, considering after hours and office hours	153
Figure 6.18	Total electrical energy consumption traces of 48 hours for our testbed building	157
Figure 6.19	Bridging energy monitoring and control with social network applications	165
Figure 6.20	A simple illustration of the multiple building microgrid networking and control structure	167
Figure 6.21	Three dimensions of features related to building concept	168
Figure 7.1	Overall structure of our design with components and their interaction	172
Figure 7.2	Integration of existing devices through “smart box” extension	174
Figure 7.3	Example dynamic multi-source energy-saving policy adjustment by the mobile devices	176
Figure 7.4	Cloud computing components and interaction with the building side servers	177
Figure 7.5	A simple example scenario of location-based automated control	178
Figure 7.6	Prototype system networking structure	179
Figure 7.7	Location history in a 24 hours' period	182
Figure 7.8	Comparison of the real energy consumption after applying our idea with the three modes' energy estimation	183

List of Tables

Table 2.1	U.S. Projects and Clusters on the Future Internet	16
Table 2.2	EU Research Projects on Future Internet	26
Table 3.1	Comparison of terminologies	69
Table 4.1	Data sources used in our evaluation and analysis	80
Table 4.2	Deployment strategies: their incentives, major motivators, and deployment order	83
Table 4.3	Algorithm M to determine multihomed sites	90
Table 4.4	APAR and RPAR for the top 15 ASs with highest APAR	99
Table 4.5	Summary of the key metrics and the major usage comparison	100
Table 5.1	Communication media, technologies, standards, and comparisons	117
Table 5.2	Energy proportionality key aspects comparison between two application areas: computers and buildings	132
Table 6.1	Regression results for electricity, heating, and cooling energy	148
Table 6.2	Comparison of energy proportionality concepts in multiple granularities	162
Table 7.1	Home electricity appliances' baseline power measurements	180
Table 7.2	Office room electricity appliances' baseline power measurements	180
Table 7.3	Daily home electricity consumption estimation of three modes	181
Table 7.4	Daily office electricity consumption estimation of three modes	182

List of Abbreviations

APAR	Absolute Prefix-to-AS Ratio
API	Application Programming Interface
AR	Aggregation Ratio
AS	Autonomous System
ASP	Application Service Provider
BGP	Border Gateway Protocol
BTU	British Thermal Unit
CAR	Cumulative Aggregation Ratio
CCN	Content-centric Networks
CDF	Cumulative Distribution
CGI	Common Gateway Interface
CIDR	Classless Inter-Domain Routing
CISE	Computer and Information Science and Engineering
CPU	Central Processing Unit
DFZ	Default Free Zone
DNS	Domain Name System
DOE	Department of Energy
DTN	Delay Tolerant Networking

EID	Endpoint ID
EU	Europeans Union
FIA	Future Internet Architecture
FIB	Forwarding Information Base
FIND	Future Internet Design
FIRE	Future Internet Research and Experimentation
FP7	European Seventh Framework Program
GENI	Global Environment for Network Innovations
GPS	Global Positioning System
HIP	Host Identity Protocol
HVAC	Heating, Ventilation, and Air Conditioning
IAB	Internet Activity Board
ICT	Information and Communication Technology
ID	Identifier
IETF	Internet Engineering Task Force
IP	Internet Protocol
IRTF	Internet Research Task Force
ISP	Internet Service Provider
LEED	Leadership in Energy & Environmental Design
LISP	Locator/ID Separation Protocol

MH	Multihomed Host
MILSA	Mobility and Multihoming supporting Identifier Locator Split Architecture
MLR	Multiple Linear Regression
MPR	Multiple Polynomial Regression
NAT	Network Address Translation
NDN	Named Data Networking
NEMO	Network Mobility
NGI	Next Generation Internet
NIA	New Internet Architecture
NMEA	National Marine Electronics Association
NSF	National Science Foundation
NWGN	New Generation Network
P2P	Peer-to-Peer
PC	Personal Computer
PC	Prefix Contribution
PA	Provider Aggregatable address
PDA	Personal Digital Assistant
PI	Provider Independent address
RHB	Realm Hierarchy Blocks
RO	Routing Optimization

RPAR	Relative Prefix-to-AS Ratio
RS	Realm Server
RRG	Routing Research Group
SCTP	Stream Control Transmission Protocol
SDN	Software Defined Networking
SDN	Service Delivery Network
SIP	Session Initiation Protocol
SQL	Structured Query Language
TCP	Transmission Control Protocol
UPnP	Universal Plug and Play
USGBC	United States Green Building Council
V2V	Vehicle-to-Vehicle
V2I	Vehicle-to-Infrastructure
XIA	eXpressive Internet Architecture
WSN	Wireless Sensor Networks
XIDs	eXpressive Identifiers

Acknowledgments

The past six years I spent here in Washington University pursuing my Ph.D. degree were a mixture of bitter and sweet. I can never forget the excitement the first time when I stepped in the Danforth campus and saw so many things different from what I had seen in China. I can never forget the friends I met here and the happy time we spent together. I can also never forget the struggles and pain I have experienced in finishing task after task and achieving one milestone after another. I am really thankful to this tremendous experience of studying and living in such a nice university as Washington University. So I would like to thank the university and the Computer Science and Engineering Department for offering me this valuable opportunity.

I would like to thank my advisor, Prof. Raj Jain, for the patience he showed and the helps he offered in guiding me through the whole process of my Ph.D. study. Given his abundant experience in both industry and academia, and his wonderful sense of the advanced technologies, I can always benefit from meeting with him and getting valuable advice to explore the novel and unknown research areas. Without doubt, Prof. Jain is a great motivator and always tries to let the students keep exploring their own potentials by themselves. I benefitted from this a lot and I am truly thankful for that. Prof. Jain is always nice and supportive, and when I was facing some difficulties, he was always willing to extend his helps and pull me out. His help comes not only from his word-by-word tireless reviewing every paper I drafted, but also from every aspect of my study and living here during the last six years.

I would like to express my sincere gratitude to the professors in my Ph.D. dissertation committee. They are: Prof. Yixin Chen, Prof. Viktor Gruev, Prof. Chenyang Lu, Prof. Paul Min from ESE department, and Prof. Yinjie Tang from EECE department. I received many useful comments and suggestions since the proposal defense and during the preparation of this dissertation. I would also to thank the members who served in my Ph.D. oral qualification exam committee. They are: Prof. Chris Gill and Prof. Roger Chamberlain.

I am also very lucky to have the opportunity to work with the excellent colleague students in our lab. They are Subharthi Paul, Chakchai So-In, Abdel Karim Al-Tamimi, and Jinjing Jiang. During these years, we worked together, coauthored papers, and shared many useful experiences. I also received much help and advice from them and I am very thankful for that. Special thanks to Jinjing, who kindly extended many helps to me to overcome many difficulties in 2008.

Though studying abroad is not easy, my life here became a lot easier because of my friends here. They include fellow students here in the Computer Science and Engineering department as well as friends outside Washington University. A short list of them is: Jinjing Jiang, Ruoyun Huang, Xuefeng Zhou, Minmin Chen, Yunpeng Xu, Lu Liu, Lin Ma, Sisu Xi, Chengjie Wu, Peng Li, Zheng Chen, Xiang Zhou, Haowei Yuan, Shengkui Gao, Shouting Huang, Yunfei Shi, Chi Zhang, Jiajing Xu, and many others. Last but not the least, I would like to thank all the members in the tennis club of the Chinese Students and Scholars Association (CSSA) of Washington University, with whom I spent many enjoyable moments together. Some of them are: Hai Deng, Xingxing Chen, Chunyan Wang, Lei Zheng, Lei Chen, Qiaofeng Xu, Zheng Luo, Fang Bo, Yilei He, and Xiao Liu.

Finally, I would extend my deepest gratitude to my beloved family members who have always provided me strong support and motivation to overcome all kinds of difficulties and to keep moving forward in my life. It is my family that made me feel warm and comfortable when I was feeling low in my life. They are: my father and mother, Chuyi Pan and Yueai Wang; my sisters, Liyan Pan and Lixia Pan; my brother, Jianfeng Pan; my nephews, Yuxuan Zheng and Yan Pan; my niece, Nuo Cheng; my brother in law, Yiqiang Zheng and Shengdong Cheng, and my sister in law, Xiaona Huang. Because of them, I could keep going and come to this point to finish my Ph.D. degree.

The research project that my research is based on was supported in part by several grants from NSF, Intel, Cisco, Huawei, and ICARE program in Washington University. Special thanks to these funding agencies and programs.

Thank you all!

Jianli Pan

Washington University in St. Louis

May 2014

ABSTRACT OF THE DISSERTATION

Next Generation Internet Architecture and Cyber-assisted

Energy Efficiency in Smart Grids of Buildings

by

Jianli Pan

Doctor of Philosophy in Computer Engineering

Washington University in St. Louis, 2014

Professor Raj Jain, Chair

Despite their huge differences, the Internet and the power grid share similar delivery patterns in the sense that the Internet delivers information from one place to another and the power grid deliver electric energy from one place to another. They are also facing their own evolution and growth challenges in their respective contexts. For Internet, its primary arena has changed dramatically from its initial academic usage to the commercial world which brought a series of significant research challenges and issues related to the Internet's architectural evolution. The power grid, on the other hand, has a strong need to transform its infrastructure with more intelligence, using networking and computing technologies. Creating a smarter power grid in energy consuming buildings will improve the operation, efficiency, security, and power quality of the grid. Thus, in this dissertation, we not only study the Internet core evolution, we also study a particular edge network application in intelligent buildings in the interdisciplinary context of networking and energy efficiency. In particular, this dissertation covers two inter-correlated parts: PART I: next generation Internet architecture and related research issues such as inter-domain routing, naming and addressing, mobility and

multihoming, renumbering, traffic engineering, security, and policy enforcement; PART II: interdisciplinary topics related to cyber-assisted energy efficiency in intelligent buildings and cyber-assisted sustainability. These two parts correlate with each other and reflect the research problems and complexity of the evolution of the Internet and consumer-side power grid, individually and interactively.

For the PART I, we study the evolution of the next generation Internet architecture and try to find new methods to address the key challenges and research issues mentioned above. We address the research challenges with a holistic, open, and evolutionary new Internet architecture named MILSA with new design principles matching the new contexts. The major contributions include: (1) designing and elaborating the novel Internet architecture framework based on Identifier (ID) Locator Split principle; (2) providing naming and addressing enhancing designs including secure IDs; (3) transition mechanisms on how the current Internet can be gradually migrated to the new architecture; (4) deployment incentives and strategies evaluation by defining a series of unified quantitative metrics; (5) a novel incrementally deployable multi-granularity multihoming framework supporting multiple types of multihoming, particularly data and user multihoming.

For PART II, we focus on the latest trends in inter-disciplinary synergy among three areas: networking and Internet technologies, smart grids, and energy. The major theme is the energy consumer-side smart grid, i.e., various intelligent buildings. We focus on applying the key related networking technologies and findings to intelligent buildings for better intelligence and energy efficiency. The major contributions include: (1) finding energy consumption patterns and issues with the existing buildings and identifying key methods to improve the energy efficiency using networking and computing technologies; (2) developing network architecture for the enterprise/home buildings and creating "energy proportionality" and enable energy optimization for

multi-scale organizations; (3) prototyping the proposed idea and carrying out experiments to demonstrate the effectiveness of our proposed ideas.

Chapter 1

Introduction

The original Internet was designed almost 40 years ago. It was initially designed for a trusted community of universities and research institutions. It is a successful example of the balance between effectiveness and complexity. Now the primary arena of the Internet has changed dramatically from its initial academic usage to the commercial world and it is broadly used in business-related context. The original designers couldn't expect such broad expansion of Internet as today. Naturally, new contexts have introduced new challenges. One of the typical examples is that the initial Internet was designed for a trusted community of universities and research institutions. However, broad commercial applications nowadays have made this assumption invalid leading to a series of security issues. Apart from the security flaw, other typical disadvantages of the current Internet design include difficulty in supporting routing scalability, mobility, multihoming, renumbering, traffic engineering, and policy enforcements [1]. Many new designs and services have to be applied via ad-hoc patches that are not consistent parts of the original architecture design. Some basic challenges cannot be solved by these patches since some of these challenges and issues are correlated, thus making it infeasible to try to solve them one by one by putting ad-hoc patches to the architecture. Moreover, new design goals urge new design principles for the future Internet. Hence, many research programs and projects have been initiated globally targeting at changes to the current Internet architecture.

Despite their huge differences, the Internet and the power grid share similar delivery patterns in the sense that the Internet delivers information from one place to another and the power grid deliver electric energy from one place to another. We can benefit from looking at them together. First, there is a surging demand from Internet users for "utility-like" computing services by cloud computing and virtual machine platforms running in large-scale data centers. Second, the information delivery

pattern has been more and more driven by contents and applications running on it, i.e., in a "top-down" style (in the protocol stack) instead of a "bottom-up" style that is driven by low layer technologies and historic protocol innovations. The surge of content service providers such as Google, Facebook, and Wikipedia is leading such new trends. At the same time, the traditional power grid has a strong urge to transform its infrastructure with more intelligence, using networking and computing technologies. Creating a smarter grid will improve the operation and energy efficiency, security, and power quality of the grid. Particularly, we found that mobile smart applications and content providers-based cloud computing platforms derived from the above two trends can be applied to the power grid arena for a smarter and more efficient grid. In this aspect, the main theme we explore and investigate is the networked intelligent buildings which are usually energy consumer-side power grids and an important part of the whole smart grids.

Hence, the primary goals and focuses of our proposed research can be divided into two correlated parts:

Part I: Next generation Internet architecture and key research issues.

In this part, we study the evolution of the next generation Internet architecture, find new methods to address a series of key challenges and research issues, look for possible new design principles and methods to design a new Internet architecture resolving these issues, and then define a series of new quantitative metrics to evaluate the effects of multiple deployment incentives and deployment strategies;

Part II: Cyber-assisted energy efficiency, smart grid, and sustainability.

In this part, we find potential ways for applying the related key technologies of networking and communication into the smart grid arena, especially in intelligent buildings and microgrids for energy efficiency optimization and sustainability. Or, in other terms, we call it cyber-assisted energy efficiency and sustainability.

The two major focuses, their relationship, and some related issues are shown in Figure 1.1. We can see from the figure that the Internet and the power grids are evolving to the future Internet and future Smart Grids, respectively. For these evolutions, they are interacting and learning from each other in both directions. For the PART I, we design the future Internet architecture to be evolvable, scalable, providing mobility support, etc. For PART II, however, we envision the future Smart Grids

to incorporate more Internet and networking technologies to make its infrastructure smarter, more energy efficient, and use more renewable energy sources for global sustainability.

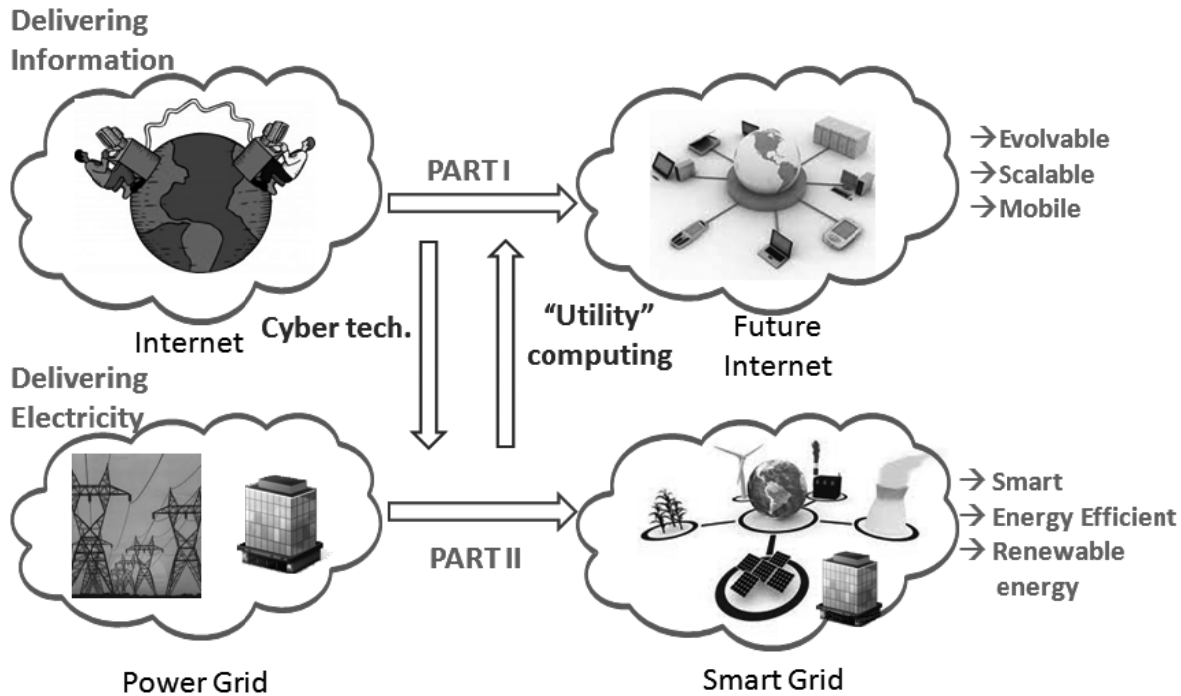

Figure 1.1. Two major research focuses and their relationship

1.1 PART I: Next Generation Internet Architecture

The research on future Internet architecture can be summarized into two major directions. The first is coming from the Internet inter-networking core which includes architectural innovations addressing the basic problems of the inter-domain routing system and proposal about holistic architectural level new alternatives. New architecture ideas aim at a series of goals like routing scalability, mobility and multihoming, renumbering, traffic engineering, and policy enforcement that need to be addressed in the new architecture. These are also the major innovations for our proposed Internet architecture. The second direction is beyond the Internet core. It is driven by specific interesting trends, including new demands such as mobility, content services, cloud computing, and Software Defined Networking (SDN) [2]. The recent dramatic developments of several content-based Internet companies like Facebook, Google, and Wikipedia have significantly changed the ways people acquire information and interact with each other, and deeply shaped the new directions for future evolution of Internet.

My research in this aspect has been focused on the design of a new future Internet architecture addressing multiple challenges. It is not a simple and easy task, and I divide them into multiple consecutive subtasks. My work in this area started with a comprehensive survey and review of the current research [3, 4], and I then proposed the detailed new designs with new design principles [5]. Specific system design aspects of the overall architecture then followed in consecutive publications [6-9]. These works coherently depict and facilitate the whole process of systematic design and evaluation efforts of a new Internet architecture. The last work is about data and user multihoming [10]. The structure of our research results for PART I is illustrated in Figure 1.2.

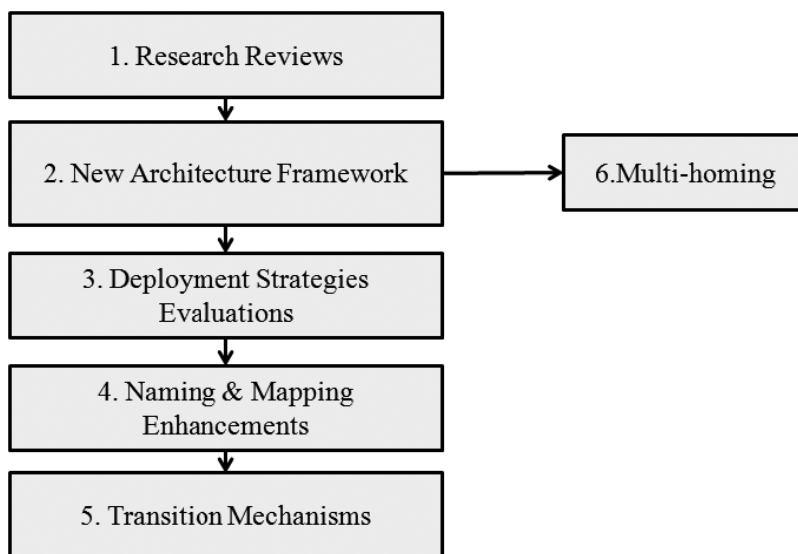

Figure 1.2. PART I research tasks and contributions

In the first sub-task, I found a lack of a thorough understanding of the "big picture" of the fast-evolving Internet architecture. We proposed a holistic architectural method which combined two classification methods, based on either technical topics [3] or based on geographical diversity [4]. In the first method, we classified most of the current research projects by their technical focuses, and revealed the major research topics and various projects related to them. For the second method, we classified the major current research projects by their geographical diversity, which presented different approaches and structures of the research programs. It helped construct a diverse view of the development in this area, with different historic backgrounds and consideration. In this research, we had two papers published in the IEEE Communications Magazine and the Journal of Computer Communication (UK), respectively in 2011.

The second sub-task is to investigate and address the research challenges, including global routing scalability, naming and addressing, mobility and multihoming, and easy transition from the current Internet. Future Internet architecture is not a single improvement on a specific topic. Assembling different clean-slate solutions targeting different aspects will not necessarily lead to a new Internet architecture. Instead, it has to be an overall redesign of a holistic architecture, taking all the issues into consideration. Specifically for the Internet inter-networking core, we proposed MILSA (Mobility and Multihoming supporting Identifier Locator Split Architecture) [5], which is a holistic and evolutionary new Internet architecture based on realm-based organizational control and new naming and addressing schemes, attacking the major deficiency of the current Internet architecture. With a series of novel designs, mobility, host multihoming and a series of other new features are intrinsically supported. The work was published in the Next Generation Internet Symposium of IEEE Globecom 2008.

Building upon the proposed basic architecture, we added several enhancements [6] to the naming and mapping mechanism to enable it to accommodate both the two competing directions of "ID locator split" on the host side and the "core edge separation" on the network side. We took advantage of the common mapping system and designed it to work in a compatible style. Such enhancements provide combined features and flexible deployment. More features, such as secure ID design and cooperative mechanisms among the three planes, enable MILSA to meet the design goals [11] of the routing research group (RRG) of the Internet Research Task Force (IRTF). This work was published in the Next Generation Internet Symposium of IEEE ICC 2009.

Regarding the transition mechanism, more advanced designs and discussions on how the current Internet can be gradually migrated to the MILSA architecture were proposed in our additional work [7]. We focused on the deployment strategies and incentives of MILSA. The basic idea of the hybrid transition mechanism is to combine the two directions and allow them to coexist by making minimalist changes to the current Internet, and to decrease the size of the global routing table step by step. The architecture allows evolution towards either of these two directions when the market makes a decision. During the transition period, we allow new MILSA hosts to be able to talk to the legacy hosts for fluent transition with backward compatibility. The work was published in the IEEE Globecom Workshop on Future Internet (FutureNet II) 2009.

The third difficult sub-task is evaluation. We found a gap between the evaluation work and the design efforts of new Internet architectures. First, new designs ignore some practical constraints, and it is difficult to evaluate a still-not-existent architecture. Second, most existing evaluation efforts on the current Internet are not for new architectures, and most evaluation experts do not know what the architecture designers really need. Due to this gap, some key information is not available to the designers, which calls for a series of unified quantitative metrics that can be used by different new architecture evaluations, particularly those based on the existing Internet instead of a clean-slate one. Using these metrics, we conducted systematic evaluation and analysis of the current Internet inter-domain routing system [8], which showed how the inter-domain routing table size can be reduced gradually when deploying new architectures at different speeds. It also revealed some direct or indirect implications to the future Internet architecture deployment, with different deployment strategies and various incentives considered in terms of their effectiveness in resolving related issues. The proposed method was published in the special issue on routing scalability of IEEE Journal on Selected Areas in Communications (JSAC) and attracted broad attention. Further enhanced measurement work of the inter-domain routing system using novel quantitatively defined metrics had been published in IEEE Systems Journal [9].

The last important research issue is multihoming which requires architecture level innovation, especially in the latest trend where contents and users are placed into more important roles in the future Internet architecture. Hence, we proposed a novel and incrementally deployable multi-granularity multihoming framework [10] that can support multiple types of multihoming, particularly data and user multihoming other than the general host and Autonomous System (AS) multihoming. The framework can be constructed step-by-step with incremental features and costs. The work was published in the Next Generation Internet Symposium of IEEE Globecom 2012.

1.2 PART II: Cyber-assisted Energy Efficiency in Smart Grids of Buildings

We define the consumer-side grids as various kinds of intelligent buildings and the microgrids formed by multiple such buildings on a local scale. Energy efficiency for the consumer-side grids is becoming more and more important. First, buildings are important environments designed to serve the human needs for multiple purposes and they are vital for the environment and sustainability.

According to a general survey [12] about the buildings' impacts to the natural environment in United States, buildings are responsible for around 38% of the total carbon dioxide emissions; 71% of the total electricity consumption; 39% of the total energy usage; 12% of water consumption; 40% of non-industrial waste. On the other hand, many studies show that conventional building design and operation are far from efficient enough to meet the challenges for the future. In other words, building is a critical source for global energy consumption and more advanced controls empowered by modern intelligent and communication technologies can potentially help reduce the over consumption significantly.

In this research of PART II, we collaborated with the Department of Energy, Environmental and Chemical Engineering (EECE) of Washington University for an interdisciplinary research project involving research areas such as networking and Internet, intelligent buildings, power grid, and energy efficiency. We focused on applying the key related networking technologies and findings to these areas, for better intelligence and energy efficiency. The main theme was the future consumer-side grid, which included both future intelligent buildings with renewable energy generating capabilities and the "microgrids" formed by multiple such buildings on a local scale. The goal was to optimize energy efficiency for the consumer-side grid. I again divide the research into multiple correlated subtasks. They coherently depict the "big picture" of current work in this area. Again, we illustrate our research tasks and contributions for PART II in a block diagram as shown in Figure 1.3.

The first sub-task was a comprehensive understanding of the intelligent buildings related technologies. The most relevant effective survey was more than ten years ago [13], and new trends need to be reflected and discussed. So we did a comprehensive survey of intelligent building related technologies, specifically with a combined perspective of networking and energy efficiency [14]. Particularly, we addressed the new trends in applying miscellaneous networking technologies like cloud computing and smart mobile phone technologies into intelligent building environments for smart home and smart healthcare systems.

The second sub-task was modeling and evaluation of individual intelligent building energy consumption, and finding methods of creating "energy proportionality" in various buildings. Buildings are significant energy consumption sources and conventional buildings' design and operation are far from efficient. Buildings are also vital for the environment and sustainability.

Hence, the goal was to apply more advanced controls empowered by modern intelligent and communication technologies to help reduce the overall energy consumption and to achieve intelligent building energy optimization. Hence, we created and implemented a unique green building testbed for energy efficiency system experimentation. We connected and integrated wireline, wireless, and powerline communication devices through a consolidated network backbone infrastructure to monitor the energy consumption in the testbed building. We proposed to study and understand the relationship between various factors that affect building energy consumption and applied networking and computing technologies to improve it. The major benefits included energy efficiency, the users' comfort and productivity, building scale energy usage optimization, lower carbon emission, and global sustainability.

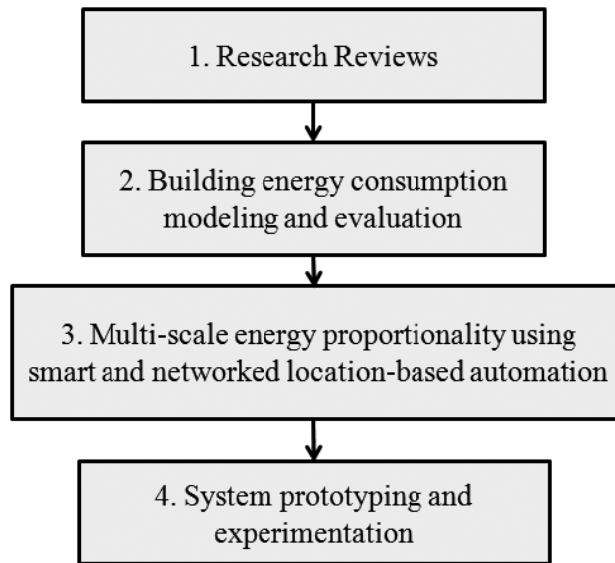

Figure 1.3. PART II research tasks and contributions

Through systematic data modeling and evaluation, we found the correlation between the energy consumption and a series of related factors like occupancy rate and environmental conditions. Using these findings, we proposed to learn from the "energy-proportional computing" history and imitate the key ideas in the building environments to enable the energy consumption to be proportional to the occupancy and the real usage [15]. Specifically, we identified a series of tentative factors and strategies that the building environments can make use of to enable and realize energy proportionality. Such methods can potentially have broad impact in saving energy and global sustainability.

The third sub-task was to propose new methods to enable the "energy proportionality" and potentially users or occupants oriented smart building automation system in actual buildings by applying multiple networking and Internet technologies. As an innovative approach, we proposed a framework for smart location-based automated energy controls in the green building testbed [16]. Using this method, occupants with smart phones were able to monitor and control their own energy policies in real time. This changed the centralized control inside the building into a distributed control paradigm. It allowed occupants with different roles to participate in the energy consumption reduction efforts. The latest information technologies, such as mobile smart device-based location service, distributed control, and cloud computing, were used in our project. With these technologies and testbed we built, we found it naturally supported in-building smart automation which was users or occupants oriented due to the usage of smart phone platforms. Also, we applied the realm-based organizational control method in MILSA [5] into the energy policy decision and formation process. The major idea and the experimental system were expected to be applied not only to green buildings but also to a vast number of the conventional buildings. The related works were published in the IEEE EnergyTech 2012, EnergyTech 2013.

Based upon the above idea, we found that a more aggressive goal than creating energy proportional buildings is to create a future of "multi-scale energy proportionality". It means that the energy proportional perspective can be realized at multiple scales. In other words, by applying a series of networking and computing technologies, we may be able to allow not only building level energy proportionality, but also energy proportionality for any group scale, for example, a single user or a specific organization. We investigated the key enabling technologies such as deep building partitioning, in-building smart monitoring and recording, smart-phone based inter-building communication and collaboration, cloud computing based energy data modeling and novel application development, and multi-scale organizational energy policy framework. We built a prototype system to prove the effectiveness of the location-based idea illustrated above. The experimental results were presented in the paper [17].

1.3 Dissertation Organization

In the rest of the dissertation, we discuss our research results in separate chapters for the two parts respectively. Specifically, Chapter 2, Chapter 3, and Chapter 4 fall into the research of PART I, and

Chapter 5, Chapter 6, and Chapter 7 are related to research of PART II. Each chapter represents our research contributions and results which were published in one or more papers. Also, for each chapter, before we illustrate and elaborate our contributions separately, we briefly discuss the related works and the state of art.

In Chapter 2, we investigate the key research topics in the area of future Internet architecture. Many on-going research projects from United States, Europeans Union (EU), Japan, China, etc. are introduced and discussed. We aim to draw an overall picture of the current research progress on the future Internet architecture. The future Internet research efforts may be classified based on their technical and geographical diversity. In this chapter, we focus on the method using geographical diversity.

In Chapter 3, we introduce the basic framework of the new Internet architecture we proposed, which we named as MILSA standing for Mobility and Multihoming supporting ID Locator Split Architecture. It is a holistic and evolutionary architecture based on realm-based organizational control and new naming and addressing schemes, attacking the major deficiency of the current Internet.

In addition, we further discuss several design enhancements to the naming and mapping mechanism in the framework. Particularly, we illustrate the details of how the ID Locator Split works in the protocol stack, how the IDs in various tiers are designed, and how the ID spaces in different tiers are mapped into lower tier IDs through dynamical bindings and mappings. These designs and features enable MILSA to meet the design goals specified by the Routing Research Group (RRG) of the Internet Research Task Force (IRTF).

Moreover, the hybrid transition mechanisms are discussed in this chapter. We design a mechanism to enable our architecture to accommodate both of the competing directions of implementing ID locator split on the host side, or on the network side which is also called "core edge separation". We took advantage of the common mapping system and designed it to work in a compatible way. Such enhancements provide combined features and flexible deployment.

Finally in this chapter, we discuss a multihoming framework supporting data and user level multihoming built upon host multihoming infrastructure, given the trend that contents and users are supposed to have more important roles in the future Internet architecture. It is designed to support step-by-step deployment with incremental features and costs.

In Chapter 4, we focus on the evaluation of the inter-domain routing system based on real routing table data for routing scalability and a series of other related issues. By defining a series of novel quantitative metrics and carrying out systematic evaluation with these metrics, we try to find useful information for the future Internet architecture design and deployment considering various incentives and strategies.

In Chapter 5, we provide a comprehensive review of the key research topics and issues on energy efficiency in buildings and microgrids using networking technologies. Combining energy efficiency and networking perspectives, we investigate the key research topics through a broad survey on the latest developments in intelligent buildings and our vision of microgrids formed by such buildings. Our aim is to draw an overall picture of the current research and potential future applications. Moreover, we further summarize and discuss in detail a series of key issues and trends that can potentially motivate and impact the adoption and development of the intelligent building and microgrid technologies in the near future.

In Chapter 6, we focus on the energy consumption data collection, modeling, and evaluation for a green building testbed. We try to find the major reasons underlying the inefficiency of the typical conventional buildings. Specifically, we find that the real energy consumption of the building is not proportional to the actual usage of weather conditions due to the reasons such as centralized control and fixed running pattern. Based on that, we propose to enable "energy proportionality" in buildings similar as the energy proportionality in computers. The benefits of the energy proportional buildings prospect include energy efficiency and savings, users' comfort and productivity, and global sustainability.

In Chapter 7, based on the findings in Chapter 4, we propose a method to enable multi-scale energy proportionality based on smart location-based automated energy control across multiple buildings. It essentially changes the centralized and fixed pattern energy control into distributed and dynamic pattern energy control, and allows not only building level energy proportionality but also energy proportionality for any group scale, for example, a single user or a specific organization. We further build a prototype system for the location-based idea and present the experimental results, which prove the effectiveness of the proposed idea.

Finally, we summarize the dissertation in Chapter 8.

Chapter 2

Review of the Research on Future Internet Architecture

In this chapter, we focus on reviewing the key research topics and research projects on the future Internet architecture based on geographical diversity. The content of this chapter is based on two of our publications [3, 4].

2.1 Introduction

The Internet has evolved from an academic network to a broad commercial platform. It has become an integral and indispensable part for our daily life, economic operation, and society. However, many technical and non-technical challenges have emerged during this process which urge for potential new Internet architectures. Technically, the current Internet was designed over 30 years ago with certain design principles. The continuing success was hindered by more and more sophisticated network attacks due to the lack of security embedded in the original architecture. Also, the IP (Internet Protocol) narrow waist means that the core architecture is hard to modify and new functions have to be implemented through myopic and clumsy ad-hoc patches on top of the existing architecture. Moreover, it has become extremely difficult to support the ever-increasing demands for security, performance reliability, social content distribution, mobility, etc. through such incremental changes. As a result, a clean-slate architecture design paradigm has been suggested by the research community to build the future Internet. From a non-technical aspect, commercial usage requires fine-grained security enforcement as opposed to the current “perimeter-based” enforcement. Security needs to be an inherent feature and integral part of the architecture. Also, there is a significant demand to transform the Internet from a simple “host-to-host” packet delivering

paradigm into a more diverse paradigm built around the data, content, and users instead of the machines. All of the above challenges lead to the research on future Internet architectures.

Future Internet architecture is not a single improvement on a specific topic or a goal. A clean-slate solution on a specific topic may assume the other parts of the architecture to be fixed and unchanged. Thus, assembling different clean-slate solutions targeting different aspects will not necessarily lead to a new Internet architecture. Instead, it has to be an overall redesign of the whole architecture taking all the issues such as security, mobility, performance reliability, etc. into consideration. It also needs to be evolvable and flexible to accommodate future changes. Most of the previous clean-slate projects were focused on individual topics. Through a collaborative and comprehensive approach, the lessons learned and research results obtained from these individual efforts can be used to build a holistic Internet architecture.

Another important aspect of the future Internet architecture research is the experimentation testbeds for new architectures. The current Internet is owned and controlled by multiple stakeholders who may not be willing to expose their networks to the risk of experimentation. So the other goal of the future Internet architecture research is to explore open virtual large-scale testbeds without affecting the existing services. New architectures can be tested, validated, and improved by running on such testbeds before they are deployed in the real world.

In summary, there are three consecutive steps leading toward a working future Internet architecture:

Step 1: Innovations in various aspects of the Internet;

Step 2: Collaborative projects putting multiple innovations into an overall networking architecture;

Step 3: Testbeds for experimentation on at-scale.

It may take a few rounds or spirals to work out a future Internet architecture that can fit all the requirements.

Future Internet research efforts may be classified based on their technical and geographical diversity. While some of the projects target at individual topics, others aim at holistic architectures by creating collaboration and synergy among individual projects. Research programs specifically aimed at the design of the future Internet have been setup in different countries around the globe including the United States, the European Union (EU), Japan, and China. The geographical diversity of research presents different approaches and structures of these different research programs. While dividing

the projects by their major topics is also possible, due to the holistic architecture goals, different projects may have some overlap.

Over the past few years' future Internet research has gathered enormous momentum as evidenced by the large number of research projects in this area. In this article, primarily based on the geographical diversity, we present a short survey limited in scope to a subset of representative projects and discuss their approaches, major features, and potential impact on the future.

2.2 Key Research Topics

In this section, we discuss some key research topics that are being addressed by different research projects.

Content or Data Oriented Paradigms. Today's Internet builds around the "narrow waist" of IP which brings the elegance of the diverse design above and below the IP, but also makes it hard to change the IP layer to adapt for future requirements. Since the primary usage of the today's Internet has changed from host-to-host communication to content distribution, it is desirable to change the architecture's narrow waist from IP to the data or content distribution. Several research projects are based on this idea. This category of new paradigms introduces challenges on data and content security and privacy, scalability of naming and aggregation, compatibility and co-working with IP, and efficiency of the new paradigm.

Mobility and Ubiquitous Access to the Networks. The Internet is experiencing a significant shift from PC-based computing to mobile computing. Mobility has become the key driver for the future Internet. The convergence demands are increasing among heterogeneous networks such as the cellular network, IP network, and wireless ad-hoc or sensor network that have different technical standards and business models. Putting mobility as the norm instead of an exception of the architecture potentially nurtures future Internet architecture with innovative scenarios and applications. Many collaborative research projects in academia and industry are pursuing such research topics with great interest. These projects also face challenges such as how to tradeoff mobility with scalability, security and privacy protection of the mobile users, mobile end-point resource usage optimization, etc.

Cloud-computing Centric Architectures. Migrating storage and computation into the “cloud” and creating a “computing utility” is a trend that demands new Internet services and applications. It creates new ways to provide global-scale resource provisioning function in a “utility-like” manner. Data centers are the key components of such new architectures. It is important to create secure, trustworthy, extensible, and robust architecture to interconnect data, control, and management planes of data centers. The cloud-computing perspective has attracted considerable research efforts and industry projects toward these goals. A major technical challenge is how to guarantee the trustworthiness of the users while maintaining the persistent service availability.

Security. Security was added into the original Internet as an additional overlay instead of an inherent part of the Internet architecture. Now security has become an important design goal for the future Internet architecture. The research is related to both technical context and economic and public policy context. From the technical aspect, it has to provide multiple granularities (encryption, authentication, authorization, etc.) for any potential use case. Also, it needs to be open and extensible to future new security related solutions. From the non-technical aspect, it should ensure a trustworthy interface among the participants (e.g., users, infrastructure providers, and content providers). There are many research projects and working groups related to security. The challenges on this topic are very diverse, and multiple participants make the issue complicated.

Experimental Testbeds. As mentioned earlier, developing new Internet architectures requires large-scale testbeds. Currently, testbed research includes multiple testbeds with different virtualization technologies and the federation and coordination among these testbeds. Research organizations from United States, European Union, and Asia have initiated several programs related to the research and implementation of large-scale testbeds. These projects explore challenges related to large-scale hardware, software, distributed system test and maintenance, security and robustness, coordination, openness, and extensibility

Besides these typical research topics, there are several others including but not limited to: networked multimedia; the “smart dust” or also called “Internet of things”; Internet services architecture. However, note that in this survey, we are not trying to enumerate all the possible topics and corresponding research projects. Instead, we focus on a representative subset and discuss a few important on-going research projects.

Due to the length limitation, we are not able to enumerate all the references for the projects discussed below. However, we do have a longer survey [3] which includes a more complete reference list for further reading.

2.3 Research Projects from United States

Research programs on future Internet architecture in United States are administrated by the National Science Foundation (NSF) directorate for Computer and Information Science and Engineering (CISE).

2.3.1 FIA and FIND

The Future Internet Architecture (FIA) program [18] of NSF is built upon the previous program Future Internet Design (FIND) program [19]. FIND funded about 50 research projects on all kinds of design aspects of the future Internet. FIA is the next phase to pull together the ideas into groups of overall architecture proposals. There are four such collaborative architecture groups funded under this program, and we introduce them here. Table 2.1 illustrates the overall such research projects from the United States, including FIA and FIND.

Table 2.1. U.S. Projects and Clusters on the Future Internet

Categories	Project or Cluster Names (Selected)
FIA	NDN, MobilityFirst, NEBULA, XIA, etc.
FIND	CABO, DAMS, Maestro, NetSerV, RNA, SISS, etc. (more than 47 totally).
GENI	Spiral 1 (5 clusters totally): DETER (1 project), PlanetLab (7 projects), ProtoGENI (5 projects), ORCA (4 projects), ORBIT (2 projects); 8 not classified; 2 analysis projects Spiral 2 : over 60 active projects as of 2009* Spiral 3 : about 100 active projects as of 2011*

*GENI design and prototyping projects can last for more than one spiral

(1) Named Data Networking (NDN)

The Named Data Networking (NDN) [20] project is led by University of California, Los Angeles with participation from about 10 universities and research institutes in the United States. The initial idea of the project can be traced to the concept of “Content-centric Networks” (CCN) by Ted Nelson in 1970s. After that, several projects such as TRIAD at Stanford and DONA project from UC Berkeley were carried out exploring the topic. In 2009, Xerox PARC (Palo Alto Research Center) released the CCNx project led by Van Jacobson who is also one of the technical leaders of the NDN project.

The basic argument of NDN project is that the primary usage of the current Internet has changed from end-to-end packet delivery to a content-centric model. The current Internet which is a “client-server” model is facing challenge in supporting secure content-oriented functionality. In this information dissemination model, the network is “transparent” and just forwarding data (i.e., it is “content-unaware”). Due to this unawareness, multiple copies of the same data are sent between end-points on the network again and again without any traffic optimization inside the network. NDN uses a different model which enables the network to focus on “what” (contents) rather than “where” (addresses). The data are named instead of their location (IP addresses). Data becomes the first-class entities in NDN. Instead of trying to secure the transmission channel or data path through encryption, NDN tries to secure the content by naming the data through a security-enhanced method. This approach allows separating trust in data from the trust between hosts and servers which can potentially enable content caching inside the network to optimize the traffic. Figure 2.1 is a simple illustration of the goal of NDN to build a “narrow waist” around content chunks instead of IP.

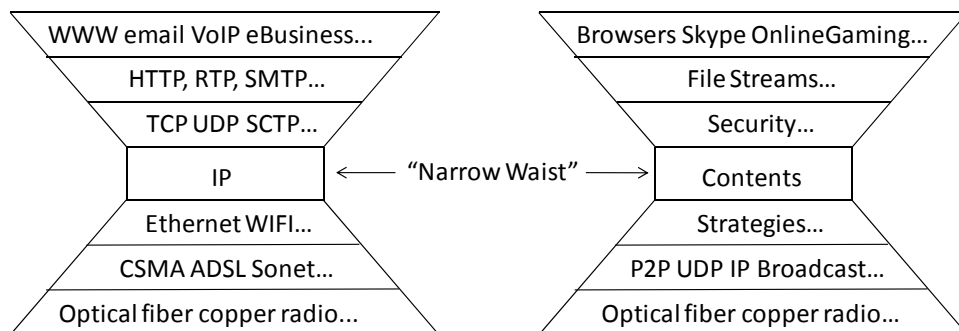

Figure 2.1. The new “narrow waist” of NDN (right) compared with current Internet (left)

NDN has several key research issues. The first one is how to find the data or how the data are named and organized to ensure fast data lookup and delivery. The proposed idea is to name the

content by a hierarchical “naming tree” which is scalable and easy to retrieve. The second research issue is data security and trustworthiness. NDN proposes to secure the data directly instead of securing the data “containers” such as files, hosts, and network connections. The contents are signed by the public keys. The third issue is the scaling of the NDN. NDN names are longer than IP addresses but the hierarchical structure helps the efficiency of lookup and global accessibility of the data.

Regarding these issues, NDN tries to address them along the way to resolve the challenges in routing scalability, security and trust models, fast data forwarding and delivery, content protection and privacy, and an underlying theory supporting the design.

(2) MobilityFirst

The MobilityFirst [21] project is led by Rutgers University with seven other universities. The basic motivation of MobilityFirst is that the current Internet is designed for interconnecting fixed endpoints. It fails to address the trend of dramatically increasing demands of mobile devices and services. The Internet usage and demand change is also a key driver for providing mobility from architectural level for the future Internet. For the near-term, MobilityFirst aims to address the cellular convergence trend motivated by the huge mobile population of 4 to 5 billion cellular devices; it also provides mobile peer-to-peer (P2P) and infostations (Delay Tolerant Networking [DTN]) application services which offer robustness in case of link/network disconnection. For the long-term, in the future, MobilityFirst has the ambition of connecting millions of cars via V2V (vehicle-to-vehicle) and V2I (vehicle-to-infrastructure) modes, which involve capabilities such as location services, georouting, and reliable multicast. Ultimately, it will introduce a pervasive system to interface human beings with the physical world, and build a future Internet around people.

The challenges addressed by MobilityFirst include stronger security and trust requirements due to open wireless access, dynamic association, privacy concern, and greater chance of network failure. MobilityFirst targets a clean-slate design directly addressing mobility such that the fixed Internet will be a special case of the general design. MobilityFirst builds the “narrow waist” of the protocol stack around several protocols: (1) global name resolution and routing service; (2) storage-aware (DTN-like) routing protocol; (3) hop-by-hop segmented transport; and (4) service and management APIs (Application Programming Interface). The DTN-like routing protocol is integrated with the use of self-certifying public key addresses for inherent trustworthiness. Functionalities such as context- and

location-aware services fit into architecture naturally. Overview of MobilityFirst architecture is shown in Figure 2.2. It shows all the building blocks mentioned above and how they work together.

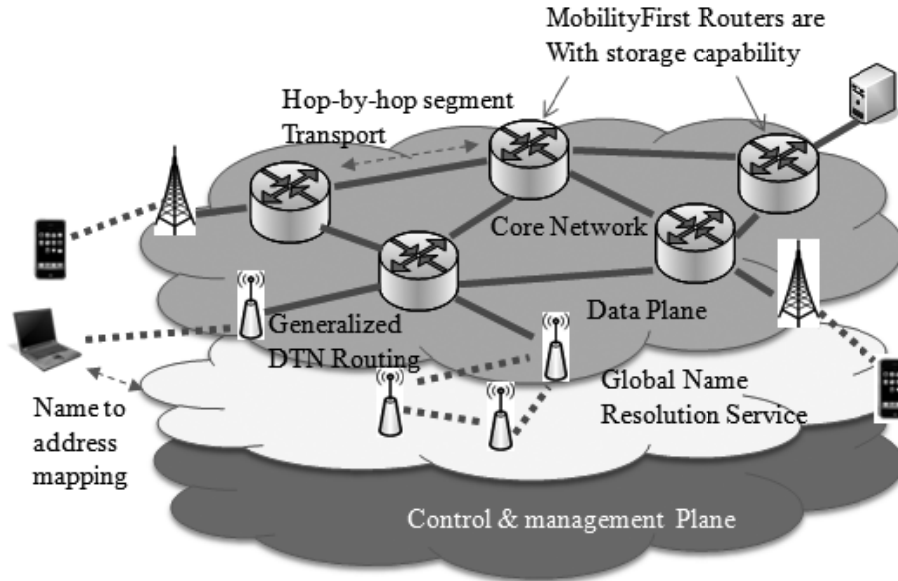

Figure 2.2. MobilityFirst architecture

Some typical research challenges of MobilityFirst include: (1) tradeoff between mobility and scalability, (2) content caching and opportunistic data delivery, (3) higher security and privacy requirements, and (4) robustness and fault tolerance.

(3) NEBULA

NEBULA [22] is another FIA project focused on building a cloud-computing centric network architecture. It is led by University of Pennsylvania with 11 other universities. NEBULA envisions the future Internet consisting of a highly-available and extensible core network interconnecting data centers to provide the utility-like services. Multiple cloud providers can use replication by themselves. Clouds comply with the agreement for mobile “roaming” users to connect to the nearest data center with a variety of access mechanisms such as wired and wireless links. NEBULA aims to design the cloud service embedded with security and trustworthiness, high service availability and reliability, integration of data centers and routers, evolvability, and economic and regulatory viability.

NEBULA design principles include: (1) reliable and high-speed core interconnecting data centers, (2) parallel paths between data centers and core routers, (3) secure both access and transit, (4) a policy-based path selection mechanism, and (5) authentication enforced during connection establishment.

With these design principles in mind, the NEBULA future Internet architecture consists of the following key parts: (1) NEBULA Data Plane (NDP) which establishes policy-compliant paths with flexible access control and defense mechanisms against availability attacks, (2) NEBULA Virtual and Extensible Networking Techniques (NVENT), which is a control plane providing access to application-selectable service and network abstractions such as redundancy, consistency and policy routing, and (3) NEBULA Core (NCore), which redundantly interconnects data centers with ultra-high availability routers. NVENT offers control plane security with policy-selectable network abstraction including multipath routing and use of new networks. NDP involves a novel approach for network path establishment and policy-controlled trustworthy paths establishment among NEBULA routers. Figure 2.3 shows the NEBULA architecture comprising the NDP, NVENT, and NCore, and shows how they interact with each other.

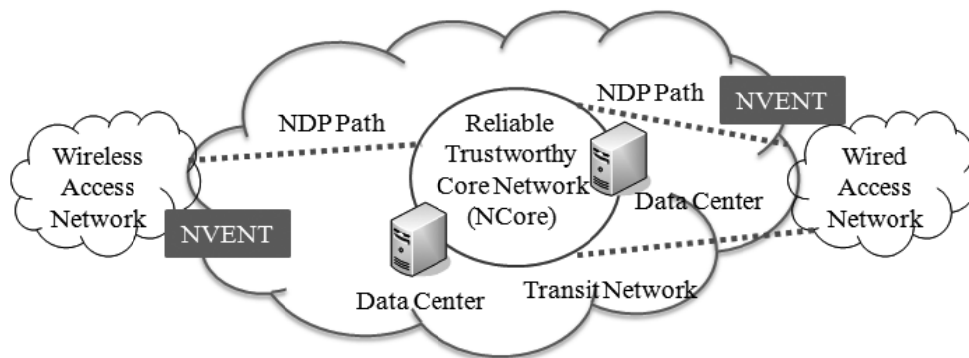

Figure 2.3. NEBULA architecture component and their interactions

(4) eXpressive Internet Architecture (XIA)

EXpressive Internet Architecture (XIA) [23] is also one of the four projects from the NSF FIA program, and was initiated by Carnegie Mellon University collaborating with two other universities. As we observe, most of the research projects on future Internet architectures realize the importance of security and consider their architecture carefully to avoid flaws of the original Internet design. However, XIA directly and explicitly targets the security issue within its design.

There are three key ideas in the XIA architecture: (1) define a rich set of building blocks or communication entities as network principals including hosts, services, contents, and future additional entities, (2) it is embedded with intrinsic security by using self-certifying identifiers for all principals for integrity and accountability properties, (3) a pervasive “narrow waist” (not limited to the host-based communication as in the current Internet) for all key functions, including access to

principals, interaction among stakeholders, and trust management; it aims to provide interoperability at all levels in the system, not just packet forwarding.

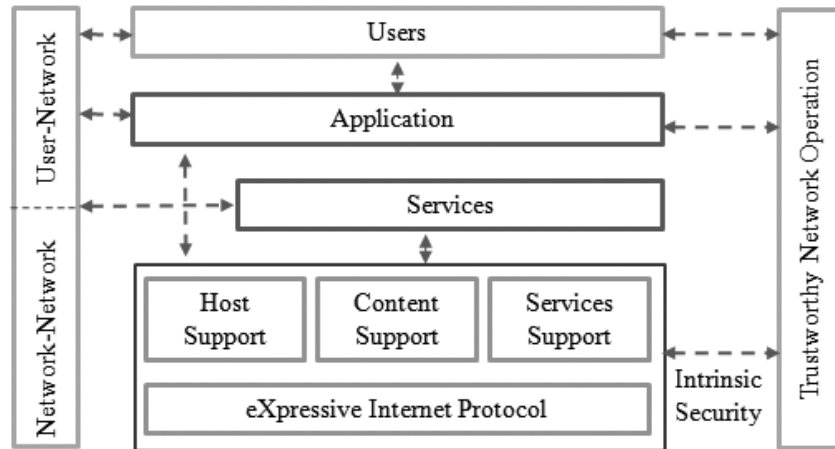

Figure 2.4. XIA components and interactions

The XIA components and their interactions are illustrated in Figure 2.4. The core of the XIA is the eXpressive Internet Protocol (XIP) supporting communication between various types of principals. Three typical XIA principal types are: content, host (defined by “who”), and service (defined by what it does). They are open to future extension. Each type of principal has a narrow waist that defines the minimal functionality required for interoperability. Principals talk to each other using eXpressive Identifiers (XIDs) which are 160 bit identifiers identifying a host, a piece of content, or a service. The XIDs are basically self-certifying identifiers taking advantage of cryptographic hash technology. By using this XID, the content retrieval no longer relies on a particular host, service or network path. XIP can then support future functions as a diverse set of services. For low-level services, it uses a path-segment-based network architecture (named “Tapa” in their previous work) as the basic building block; and builds services for content-transfer and caching and service for secure content provenance at a higher level. XIA also needs various trustworthy mechanisms and provides network availability even when under attack. Finally, XIA defines explicit interfaces between network actors with different roles and goals.

2.3.2 Global Environment for Network Innovations (GENI)

GENI [24] is a collaborative program supported by NSF aimed at providing a global large-scale experimental testbed for future Internet architecture test and validation. Started in 2005, it has attracted broad interest and participation from both academia and industry. Besides its initial

support from existing projects on a dedicated backbone network infrastructure, it also aims to attract other infrastructure platforms to participate in the federation – the device control framework to provide these participating networks with users and operating environments, to observe, measure, and record the resulting experimental outcomes. So generally, GENI is different from common testbeds in that it is a general-purpose large-scale facility that puts no limits on the network architectures, services, and applications to be evaluated; it aims to allow clean-slate designs to experiment with real users under real conditions.

The key idea of GENI is to build multiple virtualized “**slices**” out of the substrate for resource sharing and experiments. It contains two key pieces: (1) physical network substrates that are expandable building block components; and (2) a global control and management framework that assembles the building blocks together into a coherent facility. Thus, intuitively two kinds of activities will be involved in GENI testbeds: one is deploying a prototype testbed federating different small and medium ones together (e.g., the OpenFlow [25] testbed for campus networks); the other is to run observable, controllable, and recordable experiments on it.

There are several working groups concentrating on different areas, such as the control framework working group; GENI experiment workflow and service working group; campus operation, management, integration and security working group; and the instrumentation and management working group.

GENI generic control framework consists of several subsystems and corresponding basic entities: (1) aggregate and components; (2) clearinghouse; (3) research organizations, including researchers and the experiment tools; (4) experiment support service; (5) “opt-in” end users; (6) GENI operation and management. Clearinghouses from different organizations and places (e.g., those from U.S. and E.U.) can be connected through federation. By doing this, GENI not only federates with identical “GENI-like” systems, but also with any other system if they comply with a clearly-defined and relatively narrow set of interfaces for federation. With these entities and subsystems, “slices” can be created on top of the shared substrate for miscellaneous research-defined specific experiments, and the end-users can be “opted-in” onto the GENI testbed accordingly.

GENI’s research and implementation plan consists of multiple continuous “**spirals**” (currently in Spiral 5). Each spiral lasts for 12 months. Spiral 1 ran from 2008 to 2009; Spiral 2 ran from 2009 to 2010; and so on. In Spiral 1, the primary goals were to demonstrate one or more early prototypes of

the GENI control framework and end-to-end slice operation across multiple technologies. In Spiral 1, there were 5 competing approaches to the GENI control framework, called “clusters.”

Cluster A was Trial Integration Environment based on DETER (TIED) control framework focusing on federation, trust, and security. It was a one-project cluster based upon the cyber-DEfense Technology Experimental Research (DETER) control framework by USC/ISI, which is an individual “mini-GENI” testbed to demonstrate federated and coordinated network provisioning. Cluster A was particularly aimed to provide usability across multiple communities through federation. The project delivered software “fedd” as the implementation of the TIED federation architecture providing dynamic and on-demand federation, and interoperability across ProtoGENI, GENI API, and non-GENI aggregate. It included an Attribute Based Access Control (ABAC) mechanism for large-scale distributed system. It created federation with two other projects: StarBED in Japan and ProtoGENI in U.S.

Cluster B control framework was based on PlanetLab implemented by Princeton University emphasizing experiments with virtualized machines over the Internet. By the end of spiral 2, it included at least 12 projects from different universities and research institutes. The results of these projects are to be integrated into the PlanetLab testbed. PlanetLab provided “GENIwrapper” code for independent development of Aggregate Manager (AM) for Internet entities. A special “lightweight” protocol was introduced to interface the PlanetLab and the OpenFlow equipments. Through these mechanisms, other projects in the cluster can design their own substrates and component managers with different capacities and features.

Cluster C was ProtoGENI control framework by the University of Utah based on Emulab, emphasizing network control and management. By the end of spiral 2, it consisted of at least 20 projects. The cluster integrated these existing and under-construction systems to provide key GENI functions. The integration included 4 key components: backbone based on Internet2; sliceable and programmable PCs and NetFPGA cards; and subnets of wireless and wired edge clusters. Cluster C so far is the largest set of integrated projects in GENI.

Cluster D was Open Resource Control Architecture (ORCA) from Duke University and RENCi focusing on resource allocation and integration of sensor networks. By the end of spiral 2, it consisted of five projects. ORCA tried to include optical resources from the existing Metro-Scale Optical Testbed (BEN). Different from other clusters, the ORCA implementation included the

integration of the wireless/sensor prototypes. It maintains a clearinghouse for the testbeds under the ORCA control framework and through which it connects to the national backbone and is available to external researchers.

Cluster E was Open-Access Research Testbed for Next-Generation Wireless Networks (ORBIT) by Rutgers University focusing on mobile and wireless testbed networks. It included 3 projects by the end of spiral 2. The basic ORBIT did not include a full clearinghouse implementation. Cluster E tried to research how mobile and wireless work can affect and possibly be merged into the GENI architecture. WiMAX is one of the wireless network prototypes in this cluster.

A more detailed description of the clusters and their specific approaches and corresponding features can be found in our previous survey [3]. Even more details can be found from GENI project websites and wikis [24].

We can see that the Spiral 1 and 2 integrated a very wide variety of testbeds into its control framework. The spiral 2 was the second phase aiming to move towards continuous experimentation. Key developments include improved *integration* of GENI prototypes; architecture, tools, and services enabling experiment *instrumentation*; *interoperability* across GENI prototypes; and researcher *identity management*. In Spiral 3, the goal was to coordinate the design and deployment of a first GENI Instrumentation and Measurement Architecture. Supporting experimental use of GENI and making it easier to use was also a key goal. The Spiral 4 began the transition from a rapid-prototyping effort to a "real GENI" that support network research experimentation. The key goals of the current Spiral 5 include rapid growth in GENI resources, clean and consistent experimenter experience, and steadily increasing experiment and classroom use.

Another notable and unique characteristic offered by GENI is that instrumentation and measurement support have been designed into the system from the beginning since the ultimate goal of GENI is to provide an open and extensible testbed for experimentation with various new Internet architectures.

2.4 Research Projects from European Union and Asia

European Union has also initiated a bundle of research projects on the future Internet architectures. In this section, we introduce the research organized under the European Seventh Framework Program (FP7) along with that in Japan and China.

2.4.1 European Union

The European Future Internet Assembly [26] (abbreviated FIA as in U.S.) is the collaboration between the projects under FP7 on future Internet research. Currently, the Future Internet Assembly brings together about 150 projects which are part of the FP7. These projects have a wide coverage such as: network of future, cloud computing, Internet of service, trustworthy information and communication technology (ICT), networked media and search system, socio-economic aspect of the future Internet, application domain, and Future Internet Research and Experimentation (FIRE) [27]. The FIA maintains a European Future Internet Portal [28] which is an important web-portal for sharing of information and interaction among the participating projects. Multiple FIA working groups have been formed to encourage collaboration among projects.

Of these projects, around 90 of them were launched following the calls of FP7 under the “Network of the Future” Objective 1.1. They can be divided into three clusters: “Future Internet Technologies (FI)”, “Converged and Optical Networks (CaON),” and “Radio Access and Spectrum (RAS).” The total research funding since 2008 is over 390 million Euros. A subset of the projects is shown in Table 2.2.

A significant trait of the “Network of the Future” [29] is that the research projects cover very wide topics and a number of commercial organizations including traditional telecommunication companies participate in the research consortiums. Since there are a large number of projects, we selected a few representative ones and explain them in some detail. They are all under the FP7 framework based on a series of design objectives categorized by the ICT challenge #1 of building “Pervasive and Trusted Network and Service Infrastructure.”

Due to the large number of projects, for the architecture research, in this article, we selected a project named “4WARD (Architecture and Design for the Future Internet),” and for the testbed, we selected “FIRE.” We selected them due to the fact that FIRE is often deemed as the European counterpart project to GENI, and the 4WARD project aims at a general architectural level of

redesign of the Internet and we feel that it is a representative of the rest. It also involves a large number of institutions' participation and cooperation.

In the following part, we discuss these two projects briefly.

Table 2.2. EU Research Projects on Future Internet

Categories	Project names (selected)
Future Architecture and Technologies	4WARD, TRILOGY, EIFFEL, SPARC, SENSEI, Socrates, CHANGE, PSIRP, etc.
Services, Software, and Virtualization	ALERT, FAST, PLAY, S-Cube, SLA@SOI, VISION Cloud, etc.
Network Media	3DLife, COAST, COMET, FutureNEM, nextMEDIA, P2P-Next, etc.
Internet of Things	ASPIRE, COIN, CuteLoop, SYNERGY, etc.
Trustworthiness	ABC4Trust, AVANTSSAR, ECRYPT II, MASTER, uTRUSTit, etc.
Testbeds	FIRE, N4C, OPNEX, OneLAB2, PII, WISEBED, G-Lab, etc.
Others	HYDRA, INSPIRE, SOCIALNETS, etc.

*More detailed projects information can be found on EU FP7 website

(1) 4WARD

4WARD [30] is an EU FP7 project on designing a future Internet architecture led primarily by an industry consortium. The funding is over 45 million dollars for a 2-year period.

The key 4WARD design goals are: (1) to create a new “network of information” paradigm in which information objects have their own identity and do not need to be bound to hosts (somewhat similar to the goal of NDN project); (2) to design network path to be an active unit that can control itself and provide resilience and fail-over, mobility, and secure data transmission; (3) to devise “default-on” management capability which is an intrinsic part of the network itself; (4) to provide dependable instantiation and interoperation of different networks on a single infrastructure.

Thus, on one hand 4WARD promotes the innovations needed to improve a single network architecture; on the other hand, it enables multiple specialized network architectures to work together in an overall framework. There are five task components in the 4WARD research: (1) a general architecture and framework; (2) dynamic mechanisms for securely sharing resources in virtual networks; (3) “default-on” network management system; (4) communication path

architecture with multi-path and mobility support; (5) architecture for information-oriented networks.

Note that 4WARD is one of many projects under the FP7 framework on future Internet architecture research. Readers can find more information on a complete list of the projects from [26]. Some typical projects focusing on different aspects of future architecture are listed in Table 2.2.

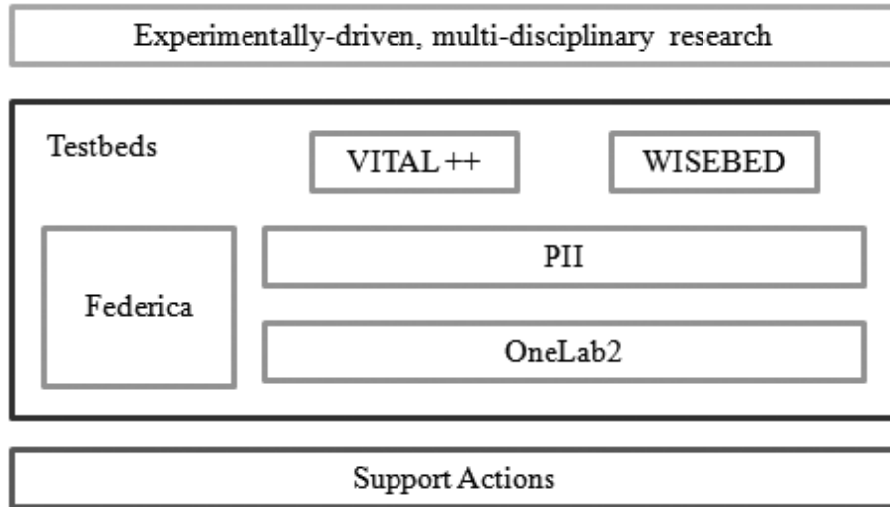

Figure 2.5. FIRE clustering of projects

(2) Future Internet Research and Experimentation (FIRE)

FIRE [27] is one of the European Union’s research projects on testbeds which is like a counterpart of GENI in the United States. FIRE was started in 2006 in FP6 and has continued through several consecutive cycles of funding. FIRE involves efforts from both industry and academia. Its “fourth wave” started in 2012 focusing on federation of FIRE facilities and on experimentation on existing facilities. Note that the FIRE project’s research is built upon the previous work on the GEANT2 (Gigabit European Academic Networking Technology) project [31], which is the infrastructure testbed connecting over 3000 research organizations in Europe.

FIRE has two interrelated dimensions: (1) to support long-term experimentally-driven research on new paradigms and concepts and architectures for the future Internet; (2) to build large-scale experimentation facility by gradually federating existing and future emerging testbeds. FIRE also expects not only to change the Internet in technical aspect but also in socio-economic terms by treating socio-economic requirements in parallel with technical requirements.

A major goal of FIRE is federation, which by definition is to unify different self-governing testbeds by a central control entity under a common set of objectives. With this goal in mind, the FIRE project can be clustered in a layered way as depicted in Figure 2.5. As shown in the figure, it contains three basic clusters. The top level cluster consists of a bundle of novel individual architectures for routing and transferring data. The bottom cluster consists of projects providing support for federation. In the middle is the federation cluster, which consists of the existing testbeds to be federated. These existing small and medium-sized testbeds can be federated gradually to meet the requirements for emerging future Internet technologies. Documents describing these sub-testbeds can be found at FIRE project website.

2.4.2 Asia

Asian countries such as Japan and China also have projects on future Internet architectures.

(1) Japan

Japan has broad collaborations with both U.S. and EU regarding the future Internet research. It participates in the PlanetLab in U.S. and the testbed in Japan is also federated with the German G-Lab facility. The Japanese research program on future Internet architecture is called New Generation Network (NWGN) sponsored by the Japan National Institute of Information and Communications Technology (NICT). The Japanese research community defines the clean-slate architecture design as “new generation” and the general IP based converged design as “next generation” (NXGN) design. The NWGN started in June 2010 and expects to change the network technologies and Internet community with broad impact in both short term (to 2015) and long-term (to 2050). Like the projects in U.S. and EU, NWGN consist of a series of sub-projects collaborated by both academia and industry. The sub-projects range from architecture designs, testbed designs, virtualization labs, and wireless testbeds to data-centric networking, service-oriented networks, advanced mobility management over network virtualization, and green computing. Rather than enumerating all projects, we briefly discuss the architecture project called “AKARI” [32] and the testbed projects “JGN2plus” [33] and “JGN-X” (JGN stands for Japan Gigabit Network). The reason we selected these projects is similar to the reason we selected FIA and GENI. AKARI is so far the biggest architectural research project in Japan; JGN2plus and JGN-X are the testbed research counterparts to GENI and FIRE.

AKARI. “AKARI” means “a small light in the darkness”. The goal of AKARI is a clean-slate approach to design a network architecture of the future based on three key design principles: (1) “crystal synthesis,” which means that keep the architecture design simple even when integrating different functions; (2) “reality connected,” which separates the physical structure with logical structure; (3) “sustainable and evolutionary,” which means it should embed the “Self-*” properties (self-organizing, self-distributed, self-emergent, etc.), and be flexible and open to the future changes. AKARI is supposed to assemble five sub-architectures models to become a blueprint NWGN: (A) an integrated sub-architecture based on layered model with cross-layer collaboration; logical identity separate from data plane (a kind of ID/locator split structure); (B) a sub-architecture that simplifies the layered model by reducing duplicated functions in lower layers; (C) a sub-architecture for QoS guarantee and multicast; (D) a sub-architecture to connect heterogeneous networks through virtualization; (E) a mobile access sub-architecture for sensor information distribution and regional adaptive services.

JGN2plus and JGN-X. The testbed of the JGN2plus is the nationwide testbed for applications and networks in Japan, and also the testbed for international federation. It includes broad collaboration from both industry and academia. It began as JGN, migrated to JGN II in 2004 and then to JGN2plus in 2008. From 2011, the testbed is under JGN-X which targets to be the real NWGN testbed to deploy and validate AKARI research results. JGN2plus provides four kinds of services: (1) Layer 3 (L3) IP connection; (2) L2 Ethernet connection; (3) optical testbed; (4) overlay service platform provisioning. There are also five sub-topics on the research of JGN2plus: (1) NWGN service platform fundamental technologies; (2) NWGN service testbed federation technology; (3) middleware and application of light path NWGN; (4) component establishment technologies for NWGN operation; (5) verification of new technologies for international operation. JGN2plus expects to create collaboration among industry, academia, and government for NWGN experiments. It also aims to contribute to the human resource development in ICT area via these experiments.

(2) China

The research projects on future Internet in China are mostly under the “863 plans”, “973 plans” and “12th Five-year Plan Projects” administrated by Ministry of Science and Technology (MOST) of China. Currently there are several on-going research projects, which include: (1) “New Generation Trustworthy Networks” (from 2007 to 2010); (2) “New Generation Network Architectures” (from

2009 to 2013); (3) “Future Internet Architectures” (from 2011 to 2015). Project 1 is still IP based network research instead of a clean-slate future Internet. It consists of research sub-projects on new network architecture, next generation broadcasting (NGB), new network services, a national testbed for new generation networks and services, new routing/switching technology, a new optical transmission network, and low-cost hybrid access equipment.

Besides the research projects on future Internet architecture, there are also on-going research projects for building China Next Generation Internet (CNGI) testbed. It is based upon previous infrastructure network testbed of China Education and Research Network (CERNET [34] and CERNET2 [35]) and China Science and Technology Network (CSTNET). A terabit optical, terabit WDM, terabit router plus IPTV testbed called (3T-NET) was also announced on July 2009 as NGB. The testbed projects are mostly industry oriented with specific interest in IPv6 related protocols and applications.

Our observation shows that the current future Internet architecture research in China leans heavily to the IPv6 related testbed which is relatively short-term. To some extent, it reveals the pain China felt due to the collision between the extreme shortage of IPv4 address space in China and the ever expanding demands from increasing customers and novel services. Longer-term research projects on innovative architectural research are still in the cradle compared to those of the U.S. and E.U.

2.5 Discussions and Perspectives

Having presented a variety of research projects, we find that there are several issues worth discussing. In this section, we give our perspective regarding these issues. Of course, there is no agreement among researchers regarding these perspectives, and none is implied.

(1) Clean-slate vs. Evolutionary. Clean-slate designs impose no restriction and assumption on the architectural design. The key idea is not to be subjected to the limitations of the existing Internet architecture. It is also called “new-generation” by Japanese and Chinese researchers. While the architectures can be revolutionary, their implementation has to be evolutionary. Today, the Internet connects billions of nodes and has millions of applications that have been developed over the last 40 years. We believe any new architecture should be designed with this reality in mind; otherwise it is bound to fail. Legacy nodes and applications should be able to communicate over the new architecture without change (with adapter nodes at the boundary), and new nodes and applications

should similarly be able to communicate over the existing Internet architecture. Of course, the services available to such users will be an intersection of those offered by both architectures. Also, the new architecture may provide adaptation facilities for legacy devices at their boundary points. Various versions of Ethernet are good examples of such backward compatibility. Some variations of IP are potential examples of missing this principle.

New architecture deployment will start in a very small scale compared to the current Internet. These early adopters should have economic incentives for change. Any architecture that requires investment without immediate payoff is bound to fail. Of course, the payoff will increase as the deployment of the new technology increases, economies of scale reduce the cost and eventually the old architecture deployed base will diminish and disappear.

(2) Integration of Security, Mobility and Other Functionalities. It is well understood and agreed that security, mobility, self-organization, disruption tolerance, and so on are some of the key required features for the future Internet. However, most of the projects, even for those collaborative ones like in FIA program, put more emphasis on a specific attribute or a specific set of problems. It seems to be a tough problem to handle many challenges in a single architecture design. Currently, for the collaborative projects such as in FIA, they are trying to integrate miscellaneous previous research results into a coherent one trying to balance some of the issues. Although different projects have different emphases, it is beneficial to create such diversity and allow a bunch of integrated architectures to potentially compete in the future. However, we believe that it is still a long way to go before a next generation architecture unifying these different lines of designs. For example, we observe that the four U.S. FIA projects concentrate on four different specific issues. Self-certifying and hash-based addresses are an effective way for security. However, security needs much more consideration from both micro and macro scope. Content- and information-centric features are also important trends, but how to integrate these differing requirements and resulting architectures is still a pending problem. We expect that more integration research will be required when such issues emerge in the future. It is therefore desirable for different projects to create some synergy for the integration process.

(3) Architectures Built around People instead of Machines. It has been widely realized that the usage pattern of Internet has changed, and the trend of building future Internet architecture around the contents, data, and users seems to be justifiable and promising in the future. Design goal

changes naturally lead to the design principle changes. Different patterns may emerge without any further synthesis. Current existing projects on future Internet architectures sort out different principles according to their own design emphases. In our perspective, it is essential and important to form a systematic and comprehensive theory in the research process rather than designing based only on experiences. It may take several continuous spirals between theoretical improvement and practical experience to achieve a sound architecture. We believe more research on this area may be desirable and meaningful for the future Internet research.

(4) Interfaces among Stakeholders. Future Internet architectures are required to provide extensible and flexible explicit interfaces among multiple stakeholders (users, Internet service providers, application service providers, data owners, and governments) to allow interaction, and enforce policies and even laws. A typical example is Facebook, which creates a complex circumstance for data, privacy, and social relationships. Societal and economic components have become indispensable factors for the future Internet. The transition from the academic Internet to a multi-functioned business-involved future Internet puts much higher requirements to the architectural supports to regulate and balance interests from all the stakeholders. For both technical and non-technical aspects, the future Internet architectures are required to provide extensible and flexible explicit interfaces among multiple actors to allow interaction, and enforce policies and even laws. The deep-merge of the Internet to everyone's daily life has made such endeavors and efforts more and more urgent and important. From our perspective, significant research efforts are still needed in aspects such as economic, society, and laws.

(5) Experimental Facilities. Most of the current testbeds for future Internet architectures research in different countries are results of previous research projects not related to future Internet architectures. The networks use different technologies and have different capabilities. Although the federation efforts are meaningful, they may be restricted in both manageability and capability by such diversity. Testbeds from different countries are also generally tailored or specialized for the architectural design projects of those countries, hence with different features and emphases. Federation and creating synergy among such testbeds may be challenging. From our perspective, such challenges also mean a valuable opportunity for research on sharing and virtualization over diverse platforms.

(6) **Service Delivery Networks.** The key trend driving the growth of Internet over the last decade is the profusion of services over the Internet. Google, Facebook, YouTube and similar services form the bulk of the Internet traffic. Cloud computing and proliferation of mobile devices has lead to further growth in services over the Internet. Therefore, Internet 3.0 [36], which is a project that the authors of this article are involved, includes developing an open and secure Service Delivery Network (SDN) architecture. This will allow telecommunication carriers to offer SDN services that can be used by many application service providers (ASPs). For example, an ASP wanting to use multiple cloud computing centers could use it to setup its own world-wide application specific network and customize it by a rule based delegation mechanism. These rules will allow ASPs to share an SDN and achieve the features required for widely distributed services, such as load balancing, fault tolerance, replication, multihoming, mobility, and strong security, customized for their application. One way to summarize this point is that service delivery should form the narrow waist of the Internet (see Figure 2.1) and content and IP are special cases of service delivery.

2.6 Brief Summary

In this chapter, we presented a survey of the current research efforts on the future Internet architectures. It is not meant to be a complete enumeration of all the projects. Instead, we focused on a series of representative research projects. The research programs and efforts from U.S., EU, and Asia are discussed. By doing this, we hope to draw an approximate overall picture of the up-to-date status in this area.

Chapter 3

MILSA Architectural Framework

In this chapter, we focus on our major work on the designs of a new Internet architecture framework, related design enhancements, transition mechanism, and a multihoming framework. The content of this chapter is based on a series of our publications [5-8, 10].

3.1 Introduction

Naming and addressing are important Internet design issues. The availability of large-scale heterogeneous networks and the request for multiple services make it necessary to identify all the objects, especially for the mobile and multihomed hosts [37]. Current IP address centered and DNS (Domain Name System) based naming and addressing scheme cannot tackle these challenges.

In the current Internet, IP address performs the dual function of “identifier” and “locator” in which identifier explains “who” the host is and locator uniquely defines “where” the host is. This overloading leads to three main problems. First, it breaches the independence between the layers in protocol stack since application programs need to use the lower layer address directly. The second concern is mobility. Currently, DNS is used to map the names in application layer to the IP addresses in the network layer to decide where to send the data packets. However, the caching mechanism in DNS and the binding of TCP (Transmission Control Protocol) connections to IP address make it hard to provide continuous connectivity for mobile users. Mobile IP [38] is one solution, but it suffers from the triangular routing problem. Routing Optimization (RO) for Mobile IPv6 [39] tries to address the problem, but requires considerable changes to both end hosts. SIP [40] supports real-time multimedia applications and high-level mobility. However, the mobility in higher layer needs more support from lower layers. The third challenge is multihoming. Current solutions require announcing Provider Independent (PI) addresses in the global routing table, which increases

routing tables' size and limits the routing scalability [41]. The details on the evaluation of routing scalability are in the next chapter.

The Internet Activity Board (IAB) workshop on routing and addressing [1] reached a consensus on the scalable routing issue and the overloaded meaning of IP addresses. It urged further discussion and experiments on decoupling the dual meaning of IP addresses in the long-term design of NGI. Currently, there are several proposals for Identifier Locator Split such as HIP [42], Shim6 [43], LISP [44], GSE [45], I3 [46], etc. But most of them cannot provide a complete solution to the naming and addressing issue in the combined context of mobility, multihoming and security.

Separating the overloaded semantics of "identifier" and "locator" in IP address will help resolve multiple problems in the current Internet. It also makes it more intuitive and easier to resolve mobility and multihoming issues. In our project, the major goal is to design a new architecture based on ID locator split and it could accommodate the two different directions and support gradual deployment and evolution before reach the next generation. It is called MILSA (Mobility and Multihoming supporting Identifier Locator Split Architecture). Specifically, the subtasks of the project include: the naming of the host IDs, design and management of the host IDs, locator based routing and the transition challenges, efficient binding and mapping between IDs and locators, the host network stack changes and designs, mobility handling after the network stack changes, security after the ID locator split, and new architecture deployment strategies and corresponding deployment sequences.

The major contents of this chapter come from several consecutive publications [5-8] related to the topic. Specifically, in paper [5] we proposed the basic framework of the MILSA architecture, and then we discussed a series of design enhancements in naming and addressing in paper [6]. Paper [7] focuses on the transition mechanism of MILSA. In paper [8], we summarized the previous contributions and presented evaluation of the MILSA effects considering various deployment incentives and strategies. The details of the evaluation on routing scalability and related issues will be in the next chapter. As a simple summary of the MILSA architecture, it is:

- (1) MILSA [5] is basically an end-host based ID locator split architecture;
- (2) It adopts a novel trust realm setup infrastructure based on the ID locator split and uses it for fast, efficient, and secure handling of a series of issues such as mobility, multihoming, scalability, renumbering, etc.

- (3) It tries to address all the problems identified by the IRTF RRG design goals (such as: routing scalability, mobility, multihoming, and traffic engineering); actually none of the other existing solutions can address them all;
- (4) It avoids the Provider Independent (PI) address usage for global routing in the long run;
- (5) It implements signaling and data separation to improve performance and efficiency;
- (6) It introduces new decoupled ID space which can facilitate further trust relationship, policy enforcements among different organizations, and it also support location privacy by proxy;
- (7) It incorporates many enhancements such as secure hierarchical ID system, multiple ID resolution and mapping, multicast, many-cast, and service integration [6].

3.2 Related Work

Regarding the above challenges, there are many research efforts from both academia and industry which lead to many new solutions with different features.

3.2.1 Proposals for Separation: Host or Network

Internet 3.0 [36, 37] presents our view on the current problems and the conceptual ways out. Based on similar ideas, there are several research efforts in both academia and industry, which lead to a series of related new solutions with different features. One of the most active research groups is the RRG [47] of IRTF, where there is also an on-going debate or dilemma on two competing directions. One is called “core-edge separation” (or “Strategy A” in Herrin’s taxonomy [1]) which is relatively an easy-to-deploy direct strategy for routing scalability requiring no changes to the end hosts. Criticisms to it include difficulty in handling mobility and multihoming, and handling the path-MTU problem [48]. Typical solutions include LISP, IVIP, DYNA, SIX/ONE, APT, TRRP (all from [47]). The other direction is called “ID locator split” in which the IDs are decoupled from locators in the hosts’ network stacks and the mapping between IDs and locators is done by a separate distributed system. This scheme is advantageous in mobility, multihoming, renumbering, etc. However, it is criticized to require host changes and has bad compatibility with the current applications, and is relatively harder to deploy. Typical solutions include HIP [42], Shim6 [43], I3 [46], Hi3 [49]. Actually both these two categories try to decouple the “ID” from “locator” in some sense though through

two different ways, i.e., decoupling in host side or in network side. These two strategies have their own advantages and disadvantages.

Critics believe that from architecture view the tunneling in the core network looks awkward. Also there is no natural way of handling host mobility and multihoming; and handling the path-MTU problem is difficult [48]. However, the core-edge separation doesn't need any upgrade or even awareness from user side which is a big advantage in deployment compared with the host-based solutions. Of the core-edge solutions, LISP [44] is being carried out by a working group in IETF and many people are contributing to it. SIX/ONE [50] is another good example which also provides insight in transition of IPv4/IPv6, host/network cooperative solution for edge network multihoming, and incremental deployment capability. APT [51] did a good job in trying to make the mapping between the delivery address space and transit address space efficient, and minimize the delay and cause minimum negative influence to the current Internet.

Decoupling the IDs from locators in the hosts' network stacks is advantageous in host mobility, multihoming, renumbering, etc. However, it is criticized to require host changes and has compatibility issues with the current applications. Actually both these two categories try to decouple the "ID" from "locator" in some sense though through two different ways, i.e., decoupling in the host or in the network.

3.2.2 Schemes for Aggregation or Different Conceptual Routing

There are also several related ideas from both academia and industry that are worth discussing. GSE [45] proposed the preliminary ID locator split idea by separating ID from locator in IPv6 address space. Although it was not adopted at that time, it provides useful ideas regarding the separation. Huston [52, 53] presented the original insight on the routing scalability challenges. Virtual Aggregation [54, 55] is a good idea for temporarily alleviating the routing table FIB (Forwarding Information Base) size problem with small cost to borrow time for new solutions. Atom policy [56] introduces an intermediate level between the Autonomous System (AS) and prefixes to improve the aggregation. There are also endeavors to find alternative inter-domain routing protocols other than BGP (Border Gateway Protocol). HLP [57] presents a hybrid link-state and path-vector protocol that can reduce the churn-rate of route updates and achieve better convergence and scalability. There is also research on compact routing [58] which allows developing routing algorithms to meet

the limits on routing table size, stretch, overhead, etc. NIRA [59] aims to provide users the ability to choose the route by themselves which is radically different from the current routing protocols. Nimrod [60] also tries to present scalable routing framework by representing and manipulating routing related information at multiple levels of abstraction.

3.2.3 Solutions for Mobility and Multihoming

There are also several papers on mobility and multihoming architectures. Mobile IPv4 [38] and Mobile IPv6 [39] are simplified versions of the host based ID locator split solutions in which the home address is used as an ID and care-of-address is used as a locator. These solutions suffer from triangular routing. SIP [40] tries to put all the functions in the application layer, and therefore, does not apply to all applications. TTR mobility [61] presents a very good mobility framework with economical consideration. For multihoming, besides the Shim6, which is basically a IPv6 host-based ID locator split multihoming solution, there are also papers [62, 63, 64] on site multihoming which have implications on the global routing scalability. NEMO [65] is an example of site mobility. In this chapter, however, we will mainly focus on host mobility.

3.2.4 Key BGP Technologies Related to Our Research

BGP itself as a de facto inter-domain routing protocol is also a research topic. There are several proposals for improving BGP to accommodate the emerging challenges. For example, inference of AS relationships out of the global routing table by GAO [66] and [67, 68] is an important foundation step towards the AS-level evaluation we have taken in this dissertation. Wang's work [69] helps us understand the transient failure and its implication to the BGP. Griffin's significant work on BGP wedgies [70] and other dynamics help us understand some basic problems and limitations of BGP. Bonaventure [71] also presents insightful thinking on building the next generation routing system. RCP [72] tries to ease the configuration and management in the AS by centralized policy and path selection decision instead of by distributed and highly meshed BGP links in local AS. Some significant work on routing policies theory and languages [73] also incite our thinking on the BGP AS overloading problem and the potential way out.

3.3 New Concepts and Terminologies

In our new design, we essentially differentiate two types of dependency relationship which are mostly intermixed in the current Internet architecture. The first type of dependency relationship is called "administrative dependency" which is usually used to denote the trust and policy boundary. For example, a user, a department, or any level of organization represent a unique administrative relationship with objects affiliated to them and the user, department, or any level of organization need to apply its policy for these objects inside its administrative boundary. We use the new term "realm" to represent such relationship. The second type of dependency relationship is called "functional dependency" which is usually used to denote the functional dependency among different catalogues of objects when they are using the Internet. For example, a user may have to depend on various hosts, such as iPhone, PDAs (Personal Digital Assistants), laptop, and desktop, to access the Internet, while these hosts further depend on the network infrastructure to send and transmit their data. We use the new term "tier" to represent such relationship. For the objects from different tiers, they usually need to set up dynamic IDs mapping to carry out the functionalities. Specifically, we define the new terms as follows:

Tier: Tier represents the basic dependence of communication entities. Depending on the functionality and resource dependency relationship in the architecture, entities are divided into different tiers such as: *application/user/data/service* (Tier 3), *networking end-hosts* (Tier 2), and *routing infrastructure* (Tier 1), as shown in Figure 3.1. A simple illustration of tier is that “a service (Tier-3 object) resides on a host (Tier-2 object) which is attached to the routing infrastructure network (Tier-1 object)”. Notice that the host/interface is the common entity that the higher-tier objects need to affiliate to. The tiers are not necessarily limited to 3 and they can be extended to accommodate future requirements. Every entity in the network belongs to a tier and carries out tier-specific functions.

Realms: Entities of the same tier group together according to their common affiliation or policies. For example, all the hosts belonging to a single organization form a realm. Similar realms exist for the other tiers. Each realm is supposed to have a **Realm Server (RS)** that controls the assignment and resolution of IDs. Objects in a realm wishing to communicate with other objects have to follow a set of policies set by the RS.

Identifier (ID): is the identity assigned to an object by its realm authority (generally RSs). It is a general term to identify the entities in the realms. Its format can be flat, hierarchical, or descriptive.

Depending on which tier the ID holders belong to, the IDs can be divided into different types such as User-ID (Tier 3), Host-ID (Tier-2), Routing-infrastructure-ID (Tier 1), and etc. Note that the Routing-infrastructure-ID is also called “locator” which is the ID of the point of attachment to the routing infrastructure tier, and it is also explained as follows.

Locator: assigned by the routing infrastructure authority uniquely identifies the current location of the object. Locators are used for routing only and all the high-level semantic initially put upon the IP address is separated into IDs. Note that we will no longer use the term “address” in our solution since it is generally believed to be overloaded; instead, we use ID and locator separately. More often, locator is associated to the network interface that uniquely identifies a network attachment point that can be located.

3.4 Design Principles and Arguments

We need to emphasize that the original Internet design principles match the original design goals and the changing of the design goals leads to changes of design principles. The book by John Day [74] is a valuable resource to refer to for the basic patterns of the network architecture. It also includes many discussions on the original principles, history lessons, and basic reasoning in the process of Internet development.

3.4.1 Design Principles

Regarding the future Internet architecture to be an evolutionary design or a clean-slate design [75, 76], we have the following design principles:

Principle 1: “Evolutional Kernel”. We keep the “evolutional kernel” of the current Internet such as: layering, packet switching, and end-to-end argument [77].

Principle 2: Variation and Diversity. The variation and diversity in the architectural, protocol, technical or application level is allowed for a plethora of mutations and let the environment select the most competitive ones. For example, we allow the ID locator split and core-edge separation to coexist in the architecture for transition, and let environmental contexts select.

Principle 3: Fitness and Synergy. Given the variation and diversity mutation, survival or not of the solution depends on the fitness of the solution to environments. In our solution, we try to make

our design fit the basic call or the most urgent problems such as routing scalability, mobility and multihoming.

With these design principles in mind, we have the following multi-tier separation design decisions in MILSA.

3.4.2 Multi-tier Separation

We observe that one of the key reasons leading to the ossification of the current Internet is the semantic overloading of multiple logical tiers. Moreover, given the perspective that the future Internet should interconnect many different technologies, the scalability requirement and convergence trends require the architecture to be open to accommodate significantly different networks, and to provide interfaces among different tiers. Our multi-tier separation is designed to match this call in the long run.

To be specific, typical separations are as follows (Figure 3.1):

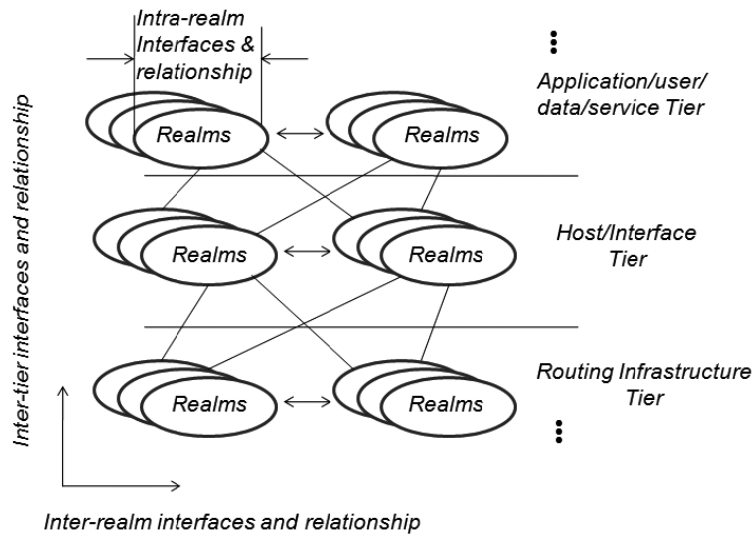

Figure 3.1. Multi-level separation and the interfaces and relationships

(1) Separation of application/user/data/service, host, and routing infrastructure tiers [78]

We picked these three tiers as the typical ones for the separation because that they represent the basic dependence and ownership of communication entities. Hosts are the common entities that the higher tier objects need to affiliate to. For example, the application/user/data/service usually should

provide service or get access to data or service through an end-host. That is to say, physically they can coexist in one machine, but logically they should be separate to avoid trouble and to enable security or higher tier goals.

Due to the current intermixing of these tiers, difficulties arise in scalability, policy enforcements, etc. A typical good attempt of trying to address the separation of routing infrastructure provider and the service provider is the CABO [79]. After the separation of the tiers, the objects in each tier are grouped into realms. Thus, we have application/user/data/service realms, host realms, and routing infrastructure realms. A typical example is that Washington University provides email service to all the faculty and students; The University may use the routing infrastructure from AT&T or Verizon to provide Internet access. Thus, the bundle of service and data provided by the university belong to one or many tier-3 realms. The hosts used to access the service may belong to one or many host realms (tier-2). The network infrastructure may be provided by AT&T, Verizon, etc. and thus belongs to one or more routing infrastructure realms (tier-1). It is also possible that in the campus area, the routing infrastructure is owned by the university itself and in this case an organization may provide multiple realms in different tiers; however, they are logically separate. Note that the direct benefits of the multi-tier separation are individual tier's policy enforcements, commercial relationships, application, service architecture setup, etc.

(2) Separation of Identifier Space from Routing Locator Space

Locators in the core MILSA networks obey the topological aggregation law to enable scalability. During the transition period, the conventional IP addresses will be treated as IDs by RSs and mapped into locators for global routing in the core routing system. Note that ID locator split or core-edge separation [7] is only the first step toward the multi-tier separation.

(3) Separation of Control and Management from Data Plane

Though control and data can be in-band, they should logically be separate. The consequence of intermixing can be the inefficiency of the signaling and control of the network, difficulty in configuration and management, and insecurity.

(4) Separation of AS Semantic Overloading

In our architecture, we decouple the "AS overloading". The basic idea is separating the host-realm's AS policy from the routing policy, so that any commercial policy of AS won't mess with routing, and

the locator aggregation can be guaranteed. Easy configuration and managements can also be achieved.

Effective definition and implementation of inter-tier and inter- realms interface and protocols are important for multi-tier separation. We observe that basically there are three types of relationships and interfaces: inter-tier, inter-realm, and intra- realm, which are shown in Figure 3.1. A simple example is that if we do ID locator split, we in fact separate the host realms from routing infrastructure realms, thus interaction functionality is required to bridge the two tiers, which is the global mapping system between IDs and locators. More inter-tier, inter-realm, and intra-realm interfaces may be defined in the future when the convergence of Internet among heterogeneous networks becomes a requirement or new services emerge.

In summary, multi-tier separation is an important feature of the MILSA architecture. Given the fact that there are many kinds of existing mutations of separation in different tiers, we generalize the idea and incorporate this idea into our architectural design. We argue that the multi-tier separation is the way to the ultimate scalability and many other benefits as discussed above.

3.5 MILSA Model

MILSA's design consists of three different functional planes. In the **data plane**, the overloaded IP address is decoupled as ID and locator and upper layer protocols are bound to ID instead of locator. **Control plane** is in charge of the mapping from ID to locator and performs the locator-based routing, and some other function related to the interaction between end-host and the routing infrastructure such as three-tier mapping and object delegation. **Management plane** function is responsible for the management of objects and realms in various tiers. MILSA follows a control and data plane separation principle to gain efficiency, controllability and manageability similar to that of the conventional telecommunication networks. Dedicated RSs form the control plane, while the data plane consists of the MILSA Border Router (MBR) hierarchy. The details of the 3D model and the functionalities in each plane are shown in Figure 3.2. Some of the major functionalities shown in the figure will be illustrated in the following sections of this chapter.

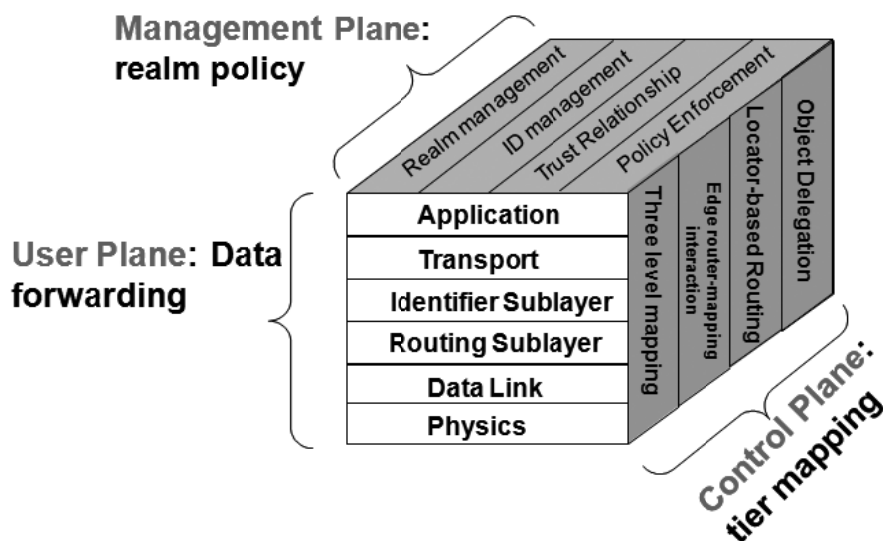

Figure 3.2. MILSA's 3D model

Figure 3.3 shows a simplified two-tier MILSA architecture. This separates Host-ID space from routing locator space, which can be seen as the first step to the future MILSA multi-tier separation. The realms in each tier can be hierarchical. For example, a two level-hierarchy for host realms is shown in Figure 3.3. The host RSs have a hierarchy similar to the host realms. Although not shown in the figure, routing infrastructure may also have a hierarchy. The host RSs map Host-ID to the locators. Signaling (control) links are set up between RSs. The hierarchical trust relationship between different groups of objects is depicted in the realm hierarchy. Realm hierarchy is mapped into the RS hierarchy by a one-to-one or one-to-many mapping (many RSs serve the same realm for robust failure tolerance or load spreading). Figure 3.3 only shows one-to-one mapping. Trust relationships are set up among RSs and they can authenticate and act as proxies for each other. MILSA objects can have multiple IDs belonging to different realms. Hosts can have multiple locators to support multihoming.

However, for future multi-tier separation, user/app/data may also have their own realms and RSs to negotiate trust or policy with other realms in different tiers and the mapping can be done between IDs of different tiers just like the mapping between Host-ID and locator. Note that realms become the basic operation unit of configuration, management, and policy enforcement. By physically and logically interacting with other realms from other tiers, the networks carry out multiple functions.

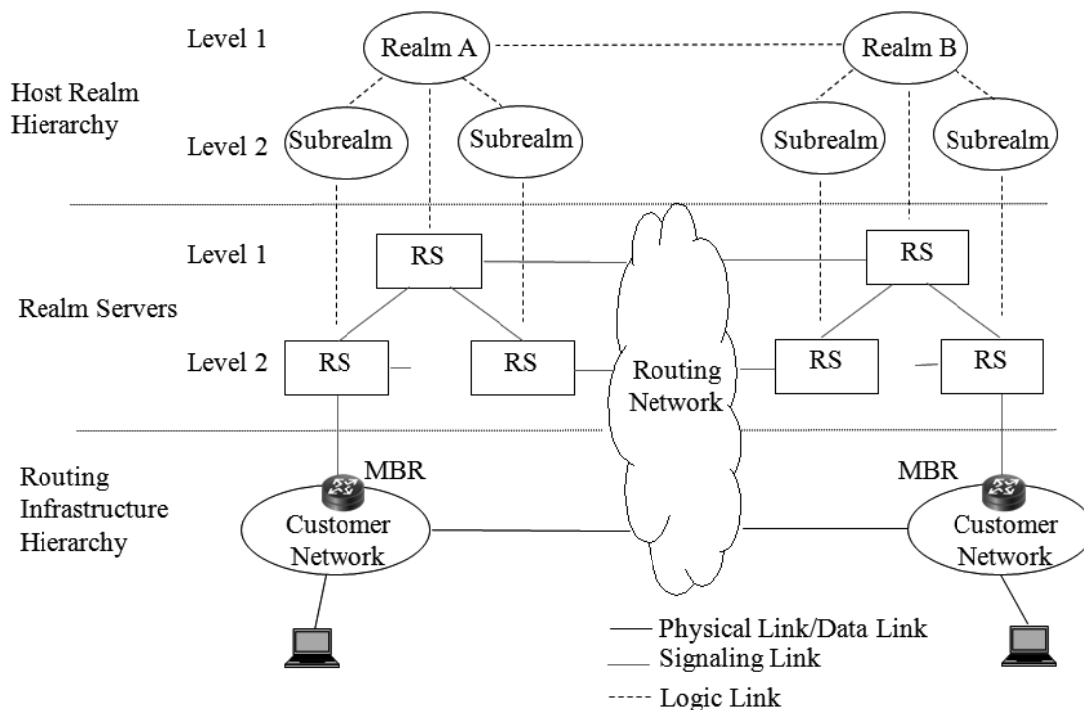

Figure 3.3 A first-step MILSA example structure (two level hierarchy)

3.6 MILSA Framework Designs

Based on the design principles and reference model, we now present the details of the key design features in the architecture.

3.6.1 ID Locator Split Argument and Design

(1) ID Locator Split Argument

Actually, a successful ID locator split prototype exists in 2G/3G networks which have been proven to be scalable and good at handling layer-2 mobility. For example, a given mobile phone number of “123-456-7890” is actually an ID instead of a locator. When the mobile phone moves to the other states, the number remains unchanged but is assigned a temporary locator, which is hierarchical and transparent to the end-users. For IP networks, the static cache-based DNS structure cannot ensure fast update when users move and change their locators. By doing ID locator split, however, we can maintain the session portability and avoid these problems through an effective global mapping system. However, it seems that it requires a new host network stack to be installed and may affect

the current applications [80]. The extra distributed global mapping system will also introduce costs. That’s why some people argue against this separation on the host side. However, in the long run, we believe that an ID locator split is inevitable in order to support better host mobility and multihoming, renumbering, better policy enforcement, and more diverse upper-layer applications. What we can do is to design and plan a good transition strategy with evolution in mind that can provide the flexibility in accommodating different alternative solutions, and allow them to evolve to either direction when the environment makes the “natural selection”. That’s why MILSA presents the hybrid design allowing the two strategies to coexist and evolve.

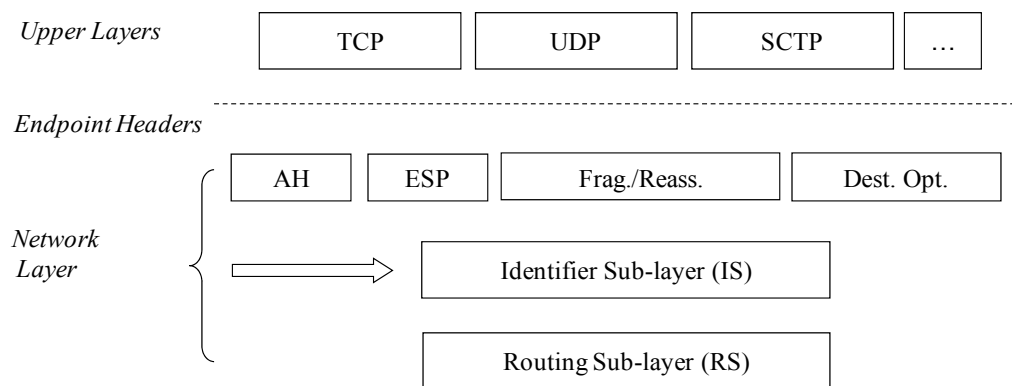

Figure 3.4. ID locator split in the protocol stack

(2) ID Locator Split Stack Design

To split IDs from locators, we introduce a new Identifier sub-layer (IS) into the network layer. As shown in Figure 3.4., the upper layers only use ID for session binding and the location information is transparent to upper layers. The lower layers don’t know about the ID used in upper layers. IS also performs mapping from ID to locators by interacting with the RSs. If host multihoming is enabled, the IS maintains the mapping state, keeps monitoring the reachability of all the links, and interacts with RSs. Multiple ID-to-locator mappings are set up in the RS, each of which represents one active locator. We put IS below IPsec’s AH and ESP headers so that the IPsec need not be aware of the locator changes due to mobility or multihoming. The fragmentation and reassembly header is also above the IS to make reassembly robust when using different locators for different fragments if there is a broken multi-path routing.

3.6.2 Different IDs and Realms

In MILSA, we have different IDs corresponding to different tier as shown in the Figure 3.5. User-IDs, Data-IDs, and Service-ID are application-level IDs similar to the DNS names, but have more meanings in helping set up user realms and enforcing policies among them. Host-ID, however, is the ID to represent the hosts on which different users run different applications. The current Internet uses the IP address as the session ID as well as routing locator which makes it difficult for host mobility and session portability. In MILSA, the host-ID is decoupled from locator to solely represent the hosts in host realms, and the locator is not used for the session identity. There is a dynamic IDs mapping and binding relationship between the IDs belonging to different tiers.

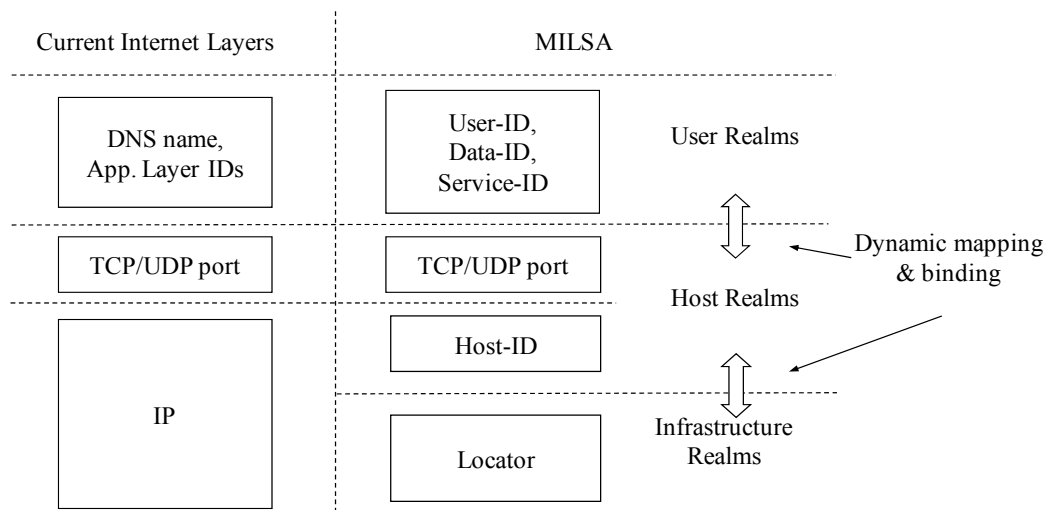

Figure 3.5. IDs in Locator, Host, and User Realms

3.6.3 IDs and Locator Structure

(1) MILSA Identifiers (MIDs)

We have different kind of MIDs such as: User-ID, Host-ID, Routing-infrastructure-ID (locator) for different tiers. Objects in each tier have a set of IDs that are registered with the RSs. The bindings of the IDs from different tiers can be dynamic. For example, if we consider the following scenario, “a user *A* roams and uses a host from *B* hotel which uses routing infrastructure provided by service provider *C*; *A* tries to access data *D* remotely”. So in this scenario, user *A* has his/her User-ID which is bound to the Host-ID he is using (belongs to hotel *B*) and further is bound to the routing locator provided by the ISP of the hotel (provider *C*). The correspondents always send packets to one or more User-, Data-, or Service-IDs, and these IDs are further translated to multiple Host-IDs owned by or temporarily

leased to the corresponding user/data/application. Each Host-ID may be translated into a set of locators due to the possible mobility of the hosts or multihomed hosts with more than one interfaces and hence locators. The IDs can be designed as locally valid and unique or globally valid and unique depending on the specific requirements. In current Internet, we have unicast and multicast addresses. Correspondingly, MILSA has unicast and multicast MIDs.

The MIDs for different tiers have different design requirements. For example, intuitively User-ID should be designed suitable for human memorization and usage; Host-ID should incorporate more hierarchical information denoting the position it resides in the logical realm, and possibly flat strings for security processing purpose; Routing-infrastructure-ID should be close to the current IP address framework with CIDR aggregation. Correspondingly, in our design, formats of MIDs are flexible. They can be *descriptive*, *hierarchical*, *flat*, or the combination of these three. They have different features which may be desirable in different circumstances. For example, flat ID is fast for machine computation and easy to be applied to cryptographic usage, but it is not easy for human understanding and memorization, and not very suitable for naming of distributed applications with multiple levels. Hierarchical ID, however, is generally more understandable by human and suitable for multi-level distributed system. Descriptive ID is more useful in the high-level attributes-based circumstances where the desired objects' attributes may not be known completely, or it can be expanded dynamically. For example, consider the “printer” case in which we may need printing service in a specific location. Here, we do not need to specify the detailed Service-ID of the printer. Instead, we can specify our requirements by giving a series of attributes describing our requirements such as:

```
“[ university = wustl [ building=bryan] [ service = printer [ type = color [ resolution =1024*768 ] ] ] ]”
```

The MILSA network will select the most suitable printing service for the user according to the preference and policy. However, for host/interface, we may need the combination of hierarchical and flat IDs to gain the benefits in realm control, policy enforcements, and security. The hierarchical ID (generally good for Host-ID) used in MILSA enables security and AAA policy enforcements among different realms. HIP's [42] flat IDs are not suitable for this purpose. It also lacks a powerful control plane to carry out efficient ID to locator mappings. Thus, in MILSA, we introduce a host MID system which combines the features of hierarchical and flat ID. The host MID contains a flat

encrypted part for security mechanisms similar to HIP. The mapping from ID to locator is done by a hierarchical RSs structure using a hybrid PUSH/PULL design to ensure mapping lookup and update performance, and the control plane is logically separated from the data forwarding plane. We argue that these new features are important for the long-term evolution.

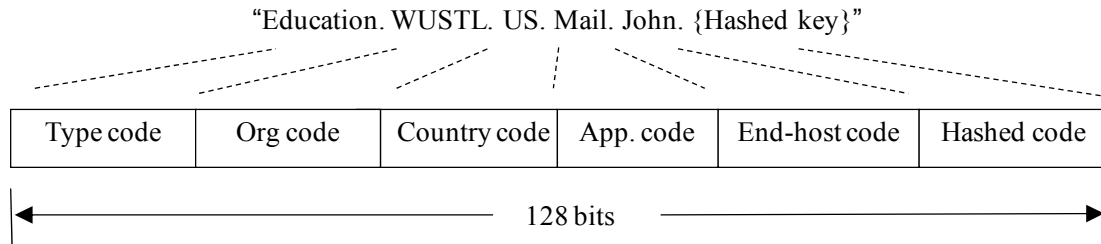

Figure 3.6. A example of fitting the MID into 128 bits code

An example of host MID is shown in Figure 3.6. However, note that it is not the actual proposed fields for a MID, instead, it is just a simple example illustrating how the host MID can be encoded into a structure compatible with the current IPv6 address paradigm.

(2) Locator

In Rekhter’s law [1] it is stated that “The addressing can follow the topology or the topology can follow addressing. Choose One.” The current Internet violates this law for scalable routing. Therefore, we require that the locators (addresses) in the new architecture obey the topological aggregation law. This requirement basically eliminates the necessity of using Provider Independent (PI) addresses for renumbering. Since locator is purely used for packet forwarding without any higher-layer meaning, the control and data plane split can also be achieved. However, to ensure the locator aggregation, efficient and automatic IP address allocation and configuration is needed. Also note that in MILSA, the locator in the core networks should also be 128 bit, and to distinguish locator from ID (both 128 bits), we can designate several special bits and encode them accordingly.

3.6.4 Three Level Mapping

We also need to clarify how MIDs are used in MILSA. We assume using the easy-to-understand DNS name or IDs in the application layer. So we allow the mapping from the general DNS name to the host MID. Note that this mapping is not very dynamic and can be implemented by adding a new Resource Record (RR) type into DNS. After getting the host MID for the given DNS name, it can

be further resolved into the current locator of the object by the RS hierarchy. However, other protocols such as LISP-DHT [81] to achieve potentially greater efficiency in this overlay network is open for future design. Figure 3.7 illustrates the three level mapping and the entities or systems involved in initiating or assisting the mapping. For the mapping from the locator to the routing paths, we allow the cooperation among the three planes to assist the decision.

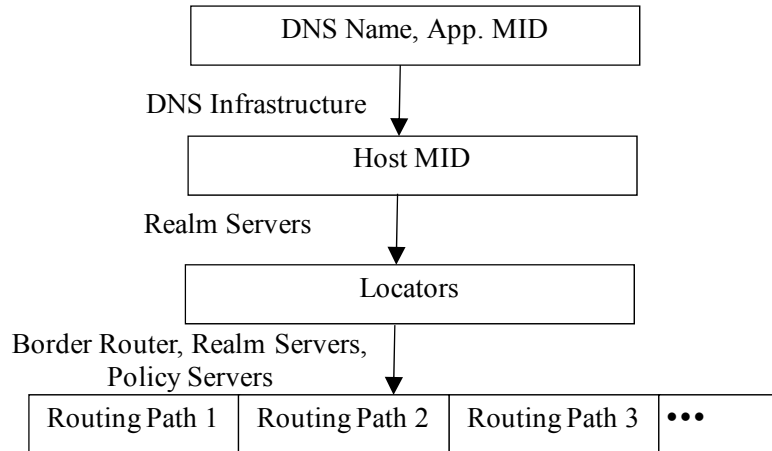

Figure 3.7. Name resolutions and mappings

3.6.5 Mobility and Multihoming

Mobility and Multihoming can be both host based and site based. Instead of using the triangular registration mechanism like in NEMO [65], site mobility in our solution makes use of the group ID and the RS-based global mapping system to keep the users and sessions of mobile network portable across the network. However, we will not address this case in this section. Site multihoming will be addressed in Section 4.5.3. Here, we will focus on the two basic host mobility and host multihoming cases.

(1) Mobility

We discuss the mobility issue in three cases:

(a) Pre-Communication Mobility

If there are no on-going sessions with other correspondents, every time the end hosts change locator due to mobility, they should update their locators in their RS.

(b) Mid-Communication Mobility

If two end hosts are talking and one end host moves and gets a new locator, it may want the correspondent to send subsequent packets to its new locator. In this case, the mobile host can directly notify the new locator to the correspondent's IS layer. The handover can be fulfilled with the assistance of lower layer (such as link layer) handover technologies. At the same time, the mobile host should update his locator with his RS just as in case (a). Note that the upper-layer sessions are bound to the MIDs instead of locators and thus won't break up when locators change. MILSA mobility model supports both peers moving and changing locators at the same time.

(c) Roaming

Suppose a roaming user needs RS from another realm because there is no such service available close to him from its own realm. In this case, first of all, trust relationship is required between the two realms. Secondly, the roaming user should pass some AAA procedure. Then the foreign RS can act as the proxy for the home RS and control messages destined to the home RS to query for the current location of the roaming user will be directed to the foreign RS. Note that only control messages go through this triangular route (only for the first packet), but not the data path.

This mobility model has several advantages: First, control and data separation facilitates the update of the binding. Second, ID Locator Split makes the locator changing transparent to the upper layer. Third, there is no triangular routing problem. Fourth, roaming function is supported.

(2) Host Multihoming

As discussed in Subsection 3.6.1, if multihoming is enabled, IS will maintain the mapping context, and more than one locator can be active for the end host and multiple MID to locator mapping entries should be registered with the RSs. IS will keep monitoring the state of these links, and update the status to the RS so that the overlay RS structure can find the current active locators of the end host. Based on the policy, the traffic may use one of the locators, or use them both for load spreading. When a link failure is detected by IS during the communication, IS will notify the correspondent to switch to another locator. It will also update the mapping entries in the RS. The second case is that if it is not in communication with other nodes, it will simply update the mapping entries at the RS.

With cooperation from RS and IS, multihoming in MILSA is efficient and the policy can be configured flexibly by the users. Also note that assisted by the IS and RS, simultaneous mobility and multihoming also becomes possible in MILSA.

(3) Multicast and Manycast

The current Internet basically doesn't support multicast well. IP multicast is not widely deployed due to scalability and other problems. Multicast in MILSA is MID-based instead of address-based which makes MILSA multicast like "deliver this information to these end-hosts" instead of "deliver these packets to these addresses". In the basic MILSA multicast design, we designate a specific *multicast MID* for a multicast group. The locator bound to this MID should be a locator of a MILSA Border Router (MBR) instead of an end-host. This MBR is in charge of maintaining a state list of the group. The end-hosts who want to join this multicast MID group register their MID and corresponding locator with the MBR which owns the group MID. After the multicast packets arrive at the MBR, it will look up the group state and replicate the packets to the members. In practice, to facilitate this procedure, we can use dedicated multicast routers.

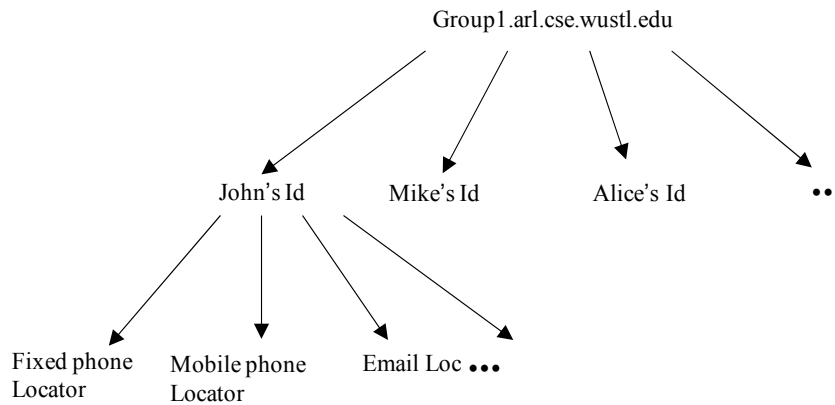

Figure 3.8. Simple many-cast example.

In MILSA, multicast server doesn't replicate the packets directly to each locator since multiple copies of the packets in the same route is not optimal. The topologically aggregated locators in the state list form a tree comprised of multicast servers. We can also use the multicast server's locator in its upper level multicast server's state list to replicate packets to the whole sub-zone instead of every locator in the state list.

We also have *manycast* in MILSA to enable the packets to be delivered to a user with different locators for different devices or services. Figure 3.8 gives a simple manycast example. Note that MILSA keeps the global routing system unaware of the multicast thus avoids the system scalability problem.

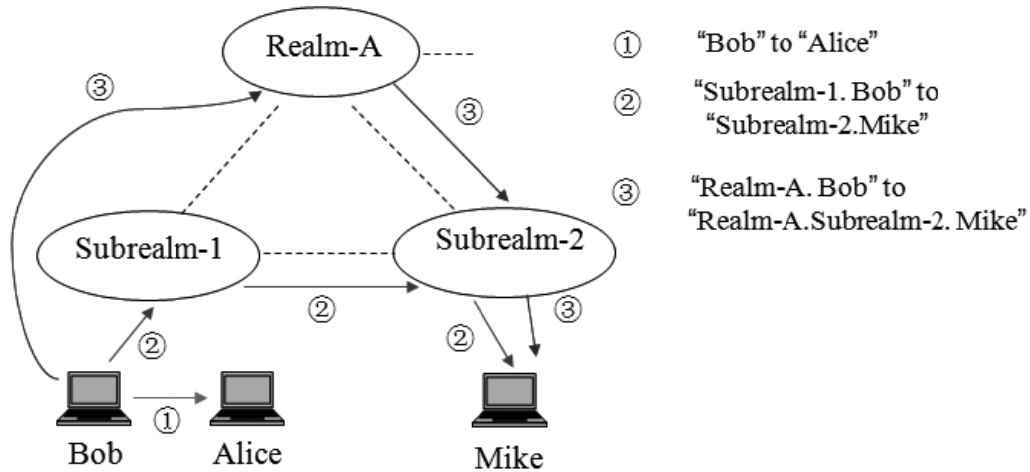

Figure 3.9. realm hierarchy and trust relationship: an example

3.6.6 Realm Hierarchy and Trust Relationship

Based on the host and routing realm structure illustrated in Figure 3.3 and the hybrid-format MIDs shown in Figure 3.6, we discuss an example of how names and MIDs are assigned and how realms are organized and interact with each other to set up trust relationship. As a typical example, in Figure 3.9, a user Bob logically belongs to Subrealm-1 in Realm-A will be assigned an MID with hierarchical part as “Realm-A.Subrealm-1.Bob”, in which the rightmost part “Bob” is the flat name in the leaf subrealm while the remaining part reflects its logical position in the realm hierarchy. The flat name part of the identifier is required to be unique in the subrealm to prevent collision. For communication inside a subrealm, we don’t have to use the full identifier. e.g., in Figure 3.9, if Bob wants to talk to Alice in the same Subrealm-1, he may just use “Alice” instead of the full identifier. If Bob wants to talk to Mike in Subrealm-2, he has to use “Subrealm-1.Bob” and send to “Subrealm-2. Mike”. Note that the grammar of MILSA IDs is somewhat similar to those of URIs (Universal Resource Identifiers).

Since one object may have more than one identifiers and it is not imperative to use identifiers strictly according to the hierarchy, it's possible for this object to get another identifier "Realm-A.Bob" directly assigned and maintained by Realm-A as long as the leftmost part of an identifier "Bob" is also unique in that realm. For example, the name "Bob" should be unique in Subrealm-1 as well as in Realm-A if he uses two identifiers as shown in Figure 3.9.

However, to benefit from this flexible multiple identifiers feature, we require that there exist trust relationship between the realm and subrealms, and among the subrealms. The trust relationship is set up and maintained based on the hierarchical structure. Higher level realms have higher privilege and are in charge of all their subrealms, and the subrealms should be authenticated before they are fully trusted by the higher level realms or their peer subrealms. The trust relationship may or may not be transitive depending on the policy. For example, realm A trusts realm B, and realm B trusts realm C. Whether realm A should trust C through B, or require direct authentication of C depends on the operational policy of A. Every realm can set its internal policy for its subrealms and can set different external policy. More explicitly, suppose in Figure 3.9, Realm-A has trust relationship with all his subrealms but there is no trust relationship between Subrealm-1 and Subrealm-2. In this case, if Bob want to talk to Mike, their signaling messages may have to pass their common parent Realm-A. Further trust relationship may be set up between Subrealm-1 and Subrealm-2, but initially they will use existing trust relationships for security. Due to the mapping between realms, the logical trust relationships between realms can be established by authentication between the realm servers (RS) of different hierarchical levels.

3.7 MILSA Transition Mechanism

Evolution of the Internet needs enough incentives or even the competence and compromise among different interest groups. So, to make the MILSA's future multi-tier separation possible, we will justify a first-step prototype of the separation between ID and locator in this section.

3.7.1 Non-technical Incentives

Regarding the pros and cons of the ID locator split and core-edge separation, there is an on-going debate on which way to go including strategies other than these two. Thus, to reduce the future potential risk, we propose a hybrid transition mechanism that can unify the "common essence"

between the two strategies and make them coexist and complement each other. Moreover, the architecture can easily evolve into any of the two directions in the future when the environment makes the selection. Thus, in MILSA, the legacy hosts can coexist and talk to the new MILSA hosts regardless of whether they use PI or PA addresses.

History has shown that every change in the Internet needs good incentives and timing. It's reasonable to require only the entities actually feeling pain to change. For example, ISP (Routers) changes for scalability, and end-user (hosts) changes for host mobility and multihoming. Those users who don't need host mobility and multihoming services may continue using the legacy host stack. They can be upgraded to MILSA stack when they actually need these services and are ready to pay for it. MILSA's hybrid transition design actually provides this option for users to choose and to bear the cost. As time goes by, it is possible that enough incentives are available to attract all the users to upgrade to the new networking stack. This idea also fit well into our design principles discussed in Section 3.4.

3.7.2 Technical Discussions

To allow the two strategies to coexist, the “common essence” that we make use of is the global mapping system that is required in both strategies. We envisage an IPv6 world in the near future where the core routing system will also be IPv6 based. We also expect that by doing our hybrid design and AS overloading decoupling, the core routing can be scalable and the current aggregation status of IPv6 network confirms this vision [82]. IPv4 address in the edge can still be used but treated by the architecture as ID, i.e., for transition purpose, the IPv4 as overloaded carrier can still be used as usual in the edge network, however, will be treated differently and separately in the edge networks. Thus, no matter whether PI or PA addresses used, or in the future the ID used, they can all be compatible in the new architecture. Moreover, the legacy hosts and the new MILSA host with the new stack can all function in the new architecture.

For communications between two new MILSA hosts which implement the ID locator split in their networking stack, they talk to each other directly using the aggregatable locators after their IDs are mapped into locators. To allow legacy hosts, however, we divide the Internet into core and edge in order to separate the global routing from the edge routing. The edge network, generally a stub Autonomous System (AS), uses a series of aggregatable or un-aggregatable prefixes and is attached

to one (for stub network with single service provider) or more (for multi-homed stub network) transit ASs. Between the stub-ASs and transit-ASs is the MBR that performs the core-edge separation, responds to mapping queries and restructures the received packets using the global routable locators in the core networks. Notice that MBR is used only in legacy stub networks to act as an “proxy” between the legacy networks and the new networks. There is no need to deploy MBR in MILSA-aware stub networks since all hosts are aware of the MID and there is no need for proxy.

Different from HRA [83] that eliminates the global reachability of the local IP addresses, in order to ensure backward compatibility, MILSA ensures that irrespective of whether the stub network uses legacy PI or PA addresses, they will still be globally reachable. However, these global unique addresses or prefixes will no longer appear in the global routing tables. Instead, the prefix will be bound to a group MID (routing infrastructure realm MID) [6] and then to an entry point locator of the MBR, i.e., a triple binding of “legacy prefix–MID–MBR locator” will be set up and maintained by the RS structure. Through this triple binding, the legacy prefix acts similar to a globally reachable ID. Since there can be many unaggregatable prefixes for an AS, many legacy prefixes can be bound to the same group MID and then to one or more entry point locators. The group MID actually represents the specific AS. Ideally, one group MID and one prefix block is enough for perfect aggregation in an AS. Since in a legacy AS, there is no split of IDs and locators, to let them exist and function in the new architecture, we need the routing infrastructure realm MID to represent the AS as an organization in the new network. Notice that this “organization” is different from the host realm since it is overloaded with two tier semantics. In summary, for legacy hosts not implementing the ID locator split, the provider network side but not the legacy side bears the responsibility of deploying MBR and realizing the split. We need to emphasize that, to avoid confusion and possible misuse, the new MILSA aggregatable locator format should be distinguished from any of the legacy hosts’ prefixes by specifying certain special bits. Note that we use indirection instead of tunneling between core and edge.

After the above changes, the legacy hosts and the new MILSA hosts will coexist in the Internet. We now discuss how they can talk to each other.

(1) Legacy hosts to legacy hosts

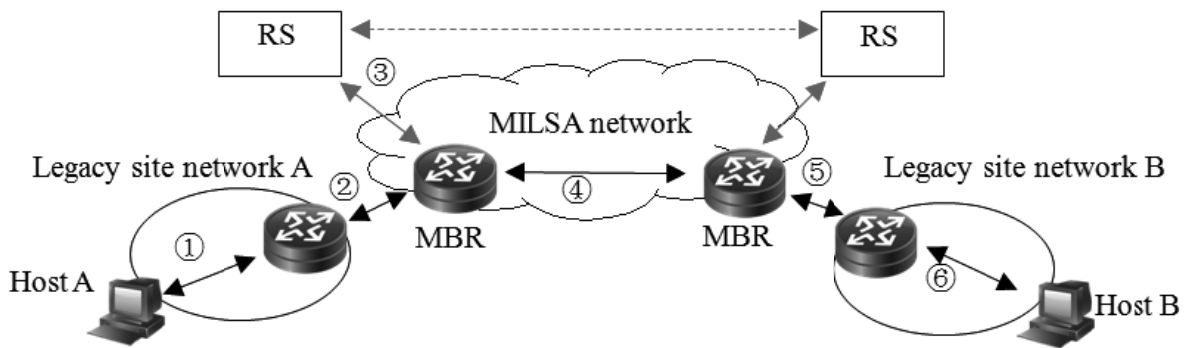

Figure 3.10. A legacy host talks to a legacy host

Regardless of whether the legacy hosts are IPv4 or IPv6 capable, they will all be globally reachable through the triple bindings registered in the global mapping system (as shown in Figure 3.10), and the traffic will go through the entry point MBR through one of its MILSA locators for inter-domain routing. When a MBR is deployed for a legacy network using IPv4 addresses (PI or PA), they are mapped to the entry point MILSA aggregatable locator. Thus, the DFZ global routing table size will reduce by one (and by N if N prefixes were announced by this site). Then the size can be reduced step by step by deploying more and more MBR routers for the legacy networks. Note that the edge networks can still use legacy IPv4 addresses without harming routing scalability and theoretically all the IPv4 addresses are portable like MID.

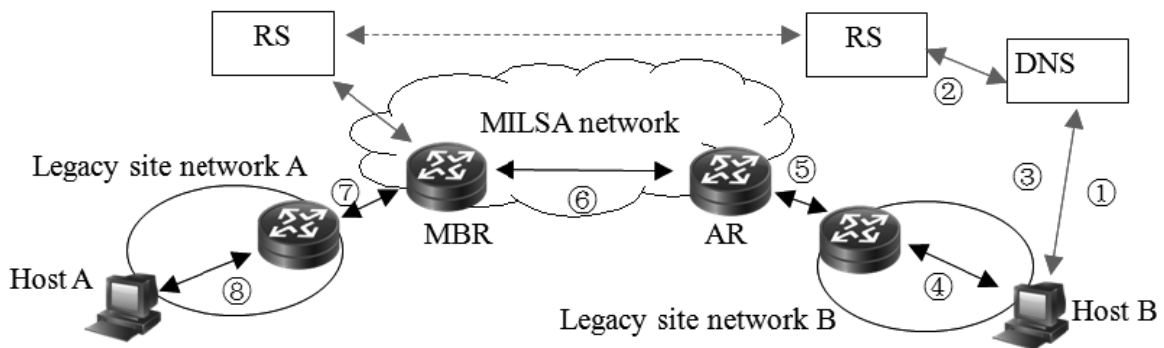

Figure 3.11. A legacy host (without MBR) talks to a legacy host (with MBR)

The hosts in the legacy networks with MBR can talk to the MILSA hosts. However, since the MBRs are deployed incrementally, those site networks that have not deployed MBR yet need to talk to MILSA networks or to sites with MBR. As shown in Figure 3.11 for the sites with MBRs, their PI prefixes are no longer used for global routing and are not in the global DFZ routing table any more, host A may not be easily reached by host B through the PI addresses and host B doesn't know anything about the MID. Note that A can talk to B since B's address is still in the global routing

table. For B to initiate a communication to A, we need some mechanism to route host B's packets destined to host A's legacy PI address to the closest MBR, which acts as a proxy between them and the MILSA networks. One possible solution is that we can get assistance from DNS. For example, suppose host A has a DNS name, then when host B queries DNS for host A, DNS server will retrieve the corresponding Host-ID (the group MID of the triple binding registered for the PI prefixes) and get the MBR locator of host A from RS, and return it to host B. Then host B can send out packets (by tunneling possibly). In Figure 3.11, AR is general Access Router that is not MILSA-aware.

(2) MILSA Hosts to MILSA Hosts

In this case, the MILSA host gets the receiver's latest MILSA locator corresponding to the given Host-ID, puts them in the packets and sends out. Since the source Host-ID and destination Host-ID, and source locator and destination locator are all included in the packets, the traffic in the reverse direction will go through a similar procedure as shown in Figure 3.12.

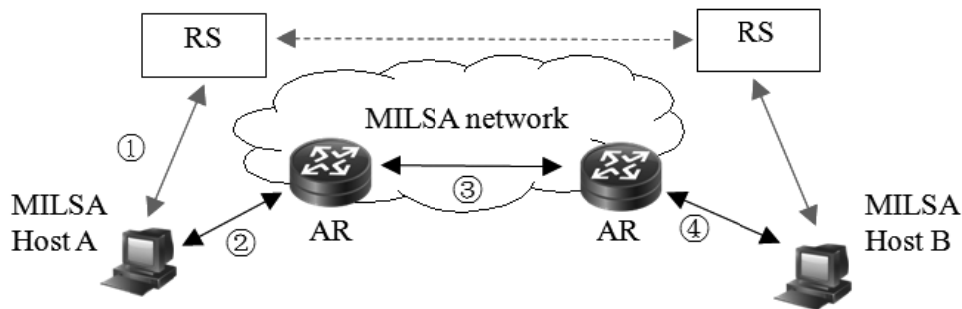

Figure 3.12. A MILSA host talks to a MILSA host

(3) MILSA Hosts to Legacy Hosts

If MILSA host A wants to talk to legacy host B that has a legacy PI/PA address and its site has an MBR, host A can easily distinguish the legacy address from MILSA ID. Thus host A sends out a query to the RS server to get the MBR locator, and then encapsulates and sends **out** the packet to the MBR of host B. Host B's MBR extracts the original address and does local routing to deliver the packets to host B. If host B's site does not have an MBR (shown in Figure 3.13), which means that the site prefix is still globally visible in the DFZ routing table, in this case, host A won't find any valid mapping from the RS. Host A uses its own MILSA locator as the source address and constructs the packets in the legacy format and sends to host B.

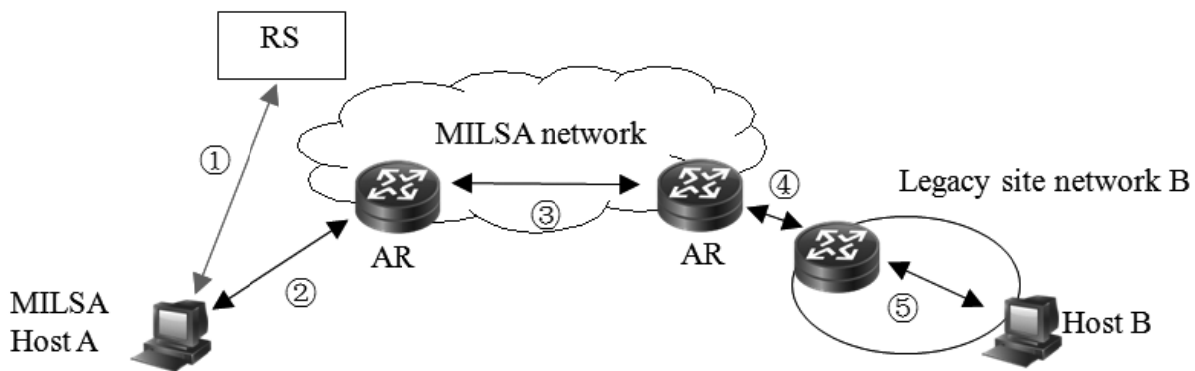

Figure 3.13. A MILSA host talks to a legacy host

In the opposite direction, for legacy hosts talking to MILSA hosts, the packets will go directly to the MILSA locator of host A. However, since MILSA’s locator can be dynamic and host B may have no idea of MID, the communication can be assisted by the DNS. The procedure is similar to Figure 3.11.

For MILSA hosts talking to legacy IPv4 hosts, the “dual stack lite” [84], or tunneling [85] mechanisms may apply, however, the topic of IPv4/IPv6 coexistence is out of the scope of this dissertation.

3.7.3 Transition Map and Scenarios

In ideal case, after the transition process is finished, all the hosts are the MILSA-aware hosts in which ID locator split and new MIDs are implemented in the host stacks, and the whole network is MILSA network in which topological aggregation is achieved and the automatic locator re-allocation mechanism is successfully implemented. However, before migrating to this final status, our hybrid transition has a very clear transition route for legacy domain and all the legacy hosts who temporarily don’t want or cannot afford to the new services, and as the mechanisms discussed above we allow all the different types of hosts to talk to each other during the transition. The basic idea is to deploy MBR which bridges between the legacy domain and the MILSA-aware domain. The transition map is shown in Figure 3.14. By adding MBR to the legacy domains gradually, incremental deployability can be achieved. Firstly, the routing scalability issue can be resolved step by step and the total inter-domain routing table size can be reduced gradually. Secondly, new features such as mobility,

multihoming, and traffic engineering will be widely supported as more and more MBRs are deployed and more domains evolve into MILSA-aware domains.

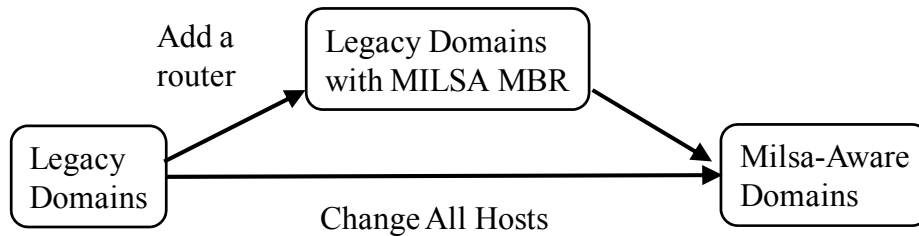

Figure 3.14. MILSA transition map

The hybrid transition mechanism supports the architecture to transit to either of the two directions in the future. The foundation of the hybrid design is the global mapping system which is used by both legacy hosts and new MILSA hosts. Suppose that in the future, if the ID locator split in the new MILSA hosts side proves to be suitable for future implementation through market competition and incentives, then the legacy PI/PA site routers will migrate to IPv6 gradually, and the legacy hosts can migrate to the new MILSA stack, then finally the MBRs serving the legacy sites can be removed and the transition is smooth.

For the other potential transition direction to the strategy A (core-edge separation), we can simply stop the support of mapping from the host ID to the locator in the realm servers while supporting the mapping from legacy prefixes to the MBR's entry point locators.

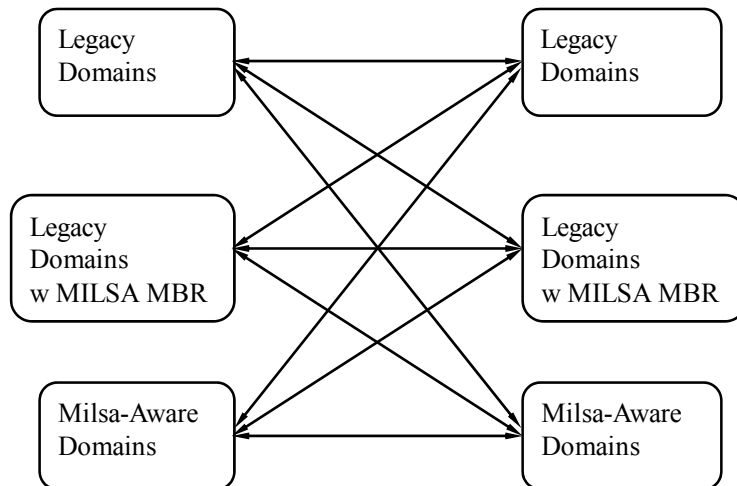

Figure 3.15. MILSA transition scenarios

As shown in Figure 3.15, six communication scenarios exist during the transition period: (1) between two MILSA-aware domains, (2) between MILSA-aware domains and legacy domains with MILSA MBR deployed, (3) between MILSA-aware domains and legacy domains, (4) between two legacy domains, (5) between two legacy domains with MILSA MBRs, and (6) between legacy domain without MBR and legacy domain with MBR.

3.8 MILSA's Answers to the RRG Design Goals

In this section, we analyze and discuss how MILSA's first step can meet the design goals [11] set by IRTF RRG.

(1) Routing Scalability

MILSA's hybrid design adopts short-term core-edge separation as well as ID locator split to tackle routing scalability challenges. Legacy IPv4 to IPv6 aggregatable address indirection in MBR makes it possible to continue using the PI addresses transparently without affecting the global routing system. The ID locator split mechanism further eliminates the necessity of using the PI addresses. Only topologically aggregated PA addresses are used in backbone routing and the size of DFZ global routing table is kept small. We can also deploy this mechanism incrementally by using the strategies we present in Subsection 4.4.2.

(2) Traffic Engineering

Traffic engineering including load balancing in the current Internet is fulfilled by injecting more-specific prefixes into the global routing table. In MILSA, a given ID can be mapped to different locators to support multihoming. These locators may be preferred with different priority or sequence for load-balancing or load-spreading. Both end-host and the RS can participate in the selection of the locator based on user's policy, and the RS can be used for traffic engineering of incoming packet flows.

(3) Mobility and Multihoming

For mobility, since upper layer protocols are bound to ID instead of IP addresses, sessions are portable for mobile users whose locators change due to mobility. MILSA supports two mobility models as discussed in Subsection 3.6.5. One is a simple model with end-to-end secure locator updates. However, to support initial communication with the ID and to allow both peers to be

mobile, global RS mapping system is needed. MILSA mobility performance can be improved with the help of layer 2 handover mechanisms and potential cross-layer designs. Note that the global RS structure also helps in supporting global roaming and object delegation. Multihoming assisted by IS and the global RS structure is easier for both IPv4 and IPv6, and multihoming no longer harms the routing scalability. The ID locator split can work closely with RS to support scalable multihoming, load balancing or spreading.

(4) Simplified Renumbering

Renumbering is no longer costly in MILSA. When users change service providers and get different locator blocks, their IDs remain unchanged. The renumbering will be taken care by the RSs to rebuild the ID to locator mappings. PI addresses are no longer in the global routing table. IP addresses used for packets filter, access control list, or management will be replaced by MID.

(5) Decoupling Location and Identification

In MILSA, the two name space of location and ID are completely decoupled both in host side and network side.

(6) Routing Quality

Latency and reliability can be used to determine the routing quality. The topological locator based routing mechanism allows MBRs to select paths with shorter delay or better performance according to inter-realm trust or other policies. Furthermore, the hybrid design reduces the size of global routing table and decreases the packet forwarding delays. Since the edge address changes are transparent to the global routing system, the routing table updating frequency can also be reduced, which increases the routing stability. However, the first packet of a new session may suffer from the latency of the mapping system. The mapping from DNS name to MID is done by DNS which is a proactive pull system. Since this mapping is static to some extent, a caching mechanism can help reduce this latency. The mapping from MID to locator is fulfilled by the dedicated RS structure (also a proactive pull system) that has predetermined locations in the backbone network, which can help reduce the latency. Proactive push systems can avoid extra delays at the cost of higher state requirement by maintaining a complete mapping database at or close to the sender. In the future, mapping systems with features of hybrid PUSH/PULL design may be investigated.

(7) Routing Security

Security is considered in several aspects of our design. MILSA uses DNS and the RS system for mapping, and MBR for packet routing. DNS is well proven to be secure in handling brutal attacks. RS is also transparent or invisible to the end-hosts. Inter-host trust and inter-realm trust are defined to provide end-to-end and inter-realm security to prevent potential DDoS attacks or limit them in a small scale. Participation of trust relationship and policies in deciding the optimal routing path can also reduce the potential indirection attacks. Moreover, since the edge network addresses are kept out of global routing system, it is hard for the attackers to inject bogus mappings into the RSs for eavesdropping, redirection, and flooding attacks.

(8) Incremental Deployability

As discussed in the above sections, MILSA's evolutionary network architecture and the hybrid transition design are highly incrementally deployable. In the next chapter, we will evaluate the inter-domain routing system and analyze the AS imbalance. With the evaluation results, we can make our deployment strategies accordingly to gain the fastest reduction for the routing table size. We will discuss more details in the next chapter.

3.9 A Novel Multihoming Framework Supporting Data and User level Multihoming

In this section, we discuss a new multihoming framework for the future Internet. We broadened the multihoming concept into multiple granularities including the user and data multihoming, and try to address the challenges through a scalable, extensible, and evolutionary 3D model. In this design, user and data multihoming can be built on top of the host multihoming through incremental slices in an evolutionary and extensible way.

3.9.1 Motivation

Multihoming is the key to continuous connectivity, improved throughput, fault tolerance, traffic engineering, load balancing, application-specific quality of service (QoS), and seamless mobility. Recent mobile devices have multiple interfaces. This ensures that the service is not interrupted if one of the interfaces is not available or breaks down. One can combine multiple interfaces to get higher throughput and to control what portion of the traffic goes over each interface (traffic engineering).

Multihoming usage is consistently increasing at all levels. Based on autonomous systems (AS) level data [8], the number of the multihomed stub ASs has doubled over the last 5 years and the routing prefixes announced by them in the global routing table have increased by 50%.

Multihoming is not properly supported in the current Internet. The original Internet design assumes single address for each named end-host. Each connection was between two IP addresses on a single path. Numerous patches have been developed and are being discussed. They include patches to DNS (e.g., “Google.com” resolves to different IP addresses in different locations), patches to inter-domain routing (CIDR [86], BGP [87], etc.), patches to intra-domain routing, development of new transport protocols (e.g., SCTP [88]), and so on. These solutions span multiple protocol stack layers and still do not satisfy the ever-increasing new needs. In particular, the Provider Independent (PI) addresses based host and AS multihoming have resulted in serious scalability issues [41] and the problem is expected to be worse with IPv6 deployment [1].

Moreover, the current multihoming practice is mostly characterized by multiple links or attachments to the Internet and only limited to hosts and ASs multihoming. However, the key trend driving the growth of Internet over the last decade is the profusion of content services such as Google, Facebook, and YouTube over the Internet. Cloud computing and proliferation of mobile devices accelerate such growth. The role of data and users needs to be present and emphasized from architecture level to address the challenges. Specifically, users and data may be “virtually” attached to multiple end-hosts. For example, multiple copies of the same data may reside in multiple hosts owned by various individuals and organizations after appropriate authorization. Access to the data may be provided without interruption by this multihoming. Similarly, a user may own multiple hosts including mobile smart phone, laptop, home desktop, office desktop, etc. He may want coordination among these hosts. Thus, between the user and these hosts, there is a virtual multi-attachment relationship. In other words, the swift migration from “connectivity-oriented” to “content-oriented” pattern of Internet requires support of such high-level “multi-attachment” features in the future Internet architecture.

In this chapter, we coin a new term “user and data multihoming” to present the emerging demands. We build upon our previous ID/locator split idea [8] which creates independent host ID namespace administrated by “*realm*” for host multihoming. The high-level user and data multihoming can be built on top of the host and AS level multihoming in an incrementally deployable and flexibly

assembled manner. The basic building blocks are the Realm Hierarchy Blocks (RHBs) and their dynamic functional combination named “*slice*”. Besides the long-term support for user and data multihoming, the new framework is also able to address the short-term routing scalability challenge by reducing the total inter-domain routing table size gradually.

The key contributions of the work in this section are that we: (1) identify and address the high-level “multi-attachment” demands from the emerging services and coin the new concepts of “user and data multihoming”, (2) leverage our previous work and create an incrementally deployable framework for multihoming supports at different levels, (3) design a framework to reflect a series of new design principles and goals, and (4) analyze the first step of our framework in addressing the short-term routing scalability issue by supporting host multihoming without using PI addresses.

3.9.2 Related Work

Multihoming can be realized in different layers of the protocol stack. An example of transport layer solution is SCTP (Stream Control Transmission Protocol) [88] which needs host stack support from all the corresponding hosts and servers, and it cannot address the scalability problem. Network layer multihoming solutions include those for IPv4 and those for IPv6. IPv4 based multihoming solutions are of two types. One is Network Address Translation (NAT) multihoming [89] which avoids dependence on the routing system for multihoming but it removes the uniqueness of the IP address and hence difficult to support “non-client-and-server” applications. The other type generally depends on the routing system (BGP multihoming [89] by using PI addresses) and violate the CIDR (Classless Inter-Domain Routing) [86] prefixes aggregation rules, and thus, suffers from the routing scalability problem. Shim6 [43] is a host-based layer-3 multihoming solution for IPv6 via ID locator split. There are other papers [90, 91, 92] on site multihoming which also have negative impacts to routing scalability.

Other works, though not directly related to the conventional multihoming, include those trying to incorporate high-level services, users, data, and contents into the network architecture design. These works attack the deficiency of the host-based design and present alternatives. Typical ones include data-oriented network (DONA) [93], content-based networks [94], and some basic idea of human-centric networks such as Mobile People Architecture (MPP) [95, 96]. However, most of them are

clean-slate designs and different from the evolutionary framework in this chapter. More detailed discussions of these solutions can be found in our surveys [3, 4].

We build upon our prior research in several areas. The **first** is a new architectural view named Internet 3.0 [36, 37] that allows policy-based secure communication that is aware of different organizational policies. The **second** is MILSA [8] which is a proof-of-concept ID locator split design introducing the ideas of host and infrastructure realms to solve the problems such as host mobility, routing scalability, and trust-based security in the current Internet. The **third** is the “Multi-tier diversified Future Internet Architecture” [97] which envisions a 3-tiered architecture: infrastructure tier, host tier, user and data tier. This enables building a host- user- or data- centric network.

3.9.3 Design Principles and Goals

(1) Design Principles

Evolution (Not Revolution) and Coexistence (Backward Compatibility): Today, Internet connects billions of nodes and has millions of applications developed over the last 40 years. We believe new architecture should be designed with this reality in mind otherwise they are bound to fail. Legacy nodes and applications should be able to communicate over the new architecture without change and the new nodes and applications should be able to communicate over the existing Internet.

Incremental Deployment: The deployment can start in a small scale and new nodes can be added incrementally. The early adopters should have economic incentives for change. The payoff will increase as the deployment of the new technology increases. Economies of scale reduce the cost and eventually the old architecture deployed base will diminish and disappear.

Organizational Control: Organizations that own the hosts, users, data, or infrastructure will want to keep control over their resources and enforce policies about who is authorized to use those resources. In case of multihoming, the organization would want to determine how their different interfaces are used.

Location Privacy: Location is private information and so the ID owner would want to control over who gets the location information. This is similar to the current cellular network where location is not divulged to correspondents.

(2) Design Goals

Extensibility and Flexibility: The new architecture has to be flexible and extensible.

Support for a Scalable Internet: The architecture should not depend on the global routing protocol (e.g., PI addresses) to fulfill multihoming. The multi-granularity multihoming is achieved by new IDs rather than the IP address space.

Easiness of Developing a Prototype for Incremental Development: We aim to follow a spiral development model. The multiple levels of multihoming are not in parallel, higher level may depend on lower level multihoming. Hence, the spiral model is appropriate for design validation as well as real incremental deployment.

Smooth Integration of Security, Mobility, and other Functions: Decoupling identities from locator and introducing new ID layer and namespace not only benefits multihoming but also the other security, mobility, and inter-domain routing solutions. However, security is not a major focus of our research.

3.9.4 Key Concepts and Models

(1) Fundamental Concepts

The first fundamental functional building unit of the framework is the “**realm**”. It is derived from our prior work [8, 37, 97] and we apply here for multihoming. It is well known that in the current Internet, the IP address is overloaded as both “identifier” and “locator”, i.e., the single namespace serves two purposes which leads to a series of problems [1]. That is the reason we bring in the new concept of “realm” which separates the organizational relationship from the physical connectivity. “**Realm**” is defined as objects grouping together according to their common affiliation or policy. For example, all the end-hosts belonging to a single logical organization form a realm; a user has his/her user realm, and a company has its own realm. Similarly, the routing service providers (ISPs) are also organized as multiple infrastructure realms, commonly known as “autonomous systems” (AS) in the current Internet. The realms can be further classified into multiple tiers. A “**tier**” is

defined as the class of realms with similar function, such as infrastructure tier, host tier, user and data tier [97].

To avoid the semantic overloading problem, realms are organized and identified by new independent ID namespaces which enable aggregatable routing locator and ID spaces, hence achieve scalability. After the logical decoupling, IDs now uniquely identify the logical entities in a specific realm, and the term “**routing**” in this framework becomes more general and represents the process that one logical entity in the realm of a certain tier finds a path to the other such entities in that tier.

Each realm has a management server called **Realm Manager (RM)**, which is equal to the realm server (RS) in other parts of the dissertation. It is responsible for important functions such as: assignment and management of the hierarchical IDs, relationship management among **its** sub-realms and with the other realms, mapping retrieval/delivery/updates, and boundary traffic policy enforcements.

We further define a new term “slice” in the multihoming framework. “**Slice**” is an extensible grouping of realm **hierarchy** (or **Realm Hierarchy Block, RHBs**) to realize specific multihoming function. It represents the re-organization of resources for functionalities such as data or user multihoming. In other words, slices are incrementally deployable, extensible, and dynamically constructible RHBs to realize the data or user multihoming function. Figure 3.16 is a simple example illustration of the concept. It consists of one slice-0 (routing slice), two slice-1s (with host, site, and enterprise multihoming) and one slice-2 (above plus user multihoming). One slice may depend on the others to realize their functionalities. For example, in Figure 3.16, slice-1 depends on slice-0, and slice-2 may depend on slice-0 and 1 for high-level multihoming. Thus, to build a slice-2, at least one slice-1 is needed. By building slices incrementally, more complex multihoming functions can be achieved with parallel or extended slices. After decoupling the conflated IP semantic and creating independent ID spaces, the slice-0 becomes a pure locator-based routing system delivering packets from location A to location B and free of the scalability difficulty. Separate host ID semantic is put into the additional RHBs to form multiple slice-1s. A **slice-1** builds upon slice-0 incrementally and is capable of the newly added host multihoming function. Similarly, after slice-1 is built, **slice-2** can be built to support user and data multihoming. Even further levels of slices can be similarly built in this extensible framework. Note that each ellipse in the figure is a RHB which consists of a hierarchy of

realms; the inner structure for each such block is similar to the hierarchical ISP realm structure of RHB-0 shown in Figure 3.19.

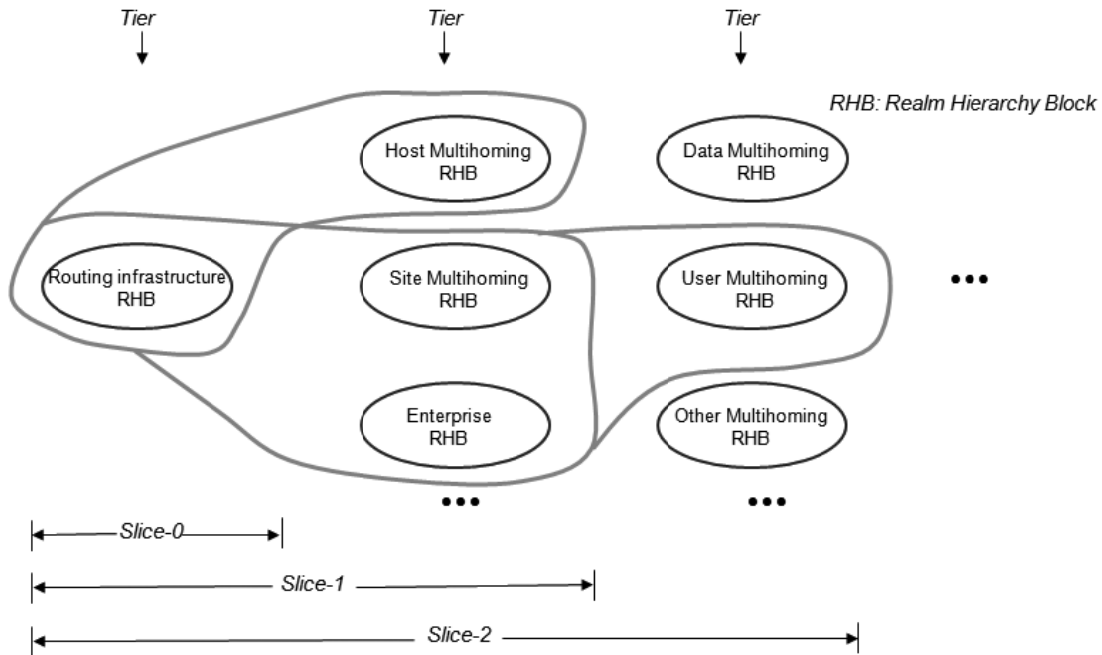

Figure 3.16. Example of flexible and extensible slice structure (Slice 0, 1, and 2)

Table 3.1 Comparison of terminologies

	Scope	Definition	Example
Layer	Single host protocol stack	Software stack encapsulated into logically dependent but implementation independent layers	Physical layer, link layer, network layer, transport layer, application layer
Hierarchy	Any hierarchical structure	Arrangement of items into vertically or horizontally ordered set or acyclic directed graph	Routing hierarchy, social hierarchy
Realm	Same organization or policy boundary	Objects grouped together according to common affiliation or policy	A user realm, a company realm, a department realm, a routing realm
Tier	Multiple realms	Realms with similar function	Infrastructure tier, host tier, data tier
Slice	Across multiple tiers and RHBs	Extensible grouping of realms or RHBs to realize specific multihoming function	Slice-0, slice-1, slice-2

Note that slice is different from the “layer” concept in the protocol stack since layers depict the software structure in a single networked machine, while slice describes the macro-scale structure

constructed by realm blocks for a specific multihoming function. Since we inherit multiple terms from our previous work and introduce new multihoming function units, we summarize and compare them in Table 3.1.

(2) Simple Host, User, and Data Multihoming Examples

Host Multihoming We present a simple example on how the host multihoming works in this framework. In Figure 3.17, a multihomed host (MH) is connected to ISP A and B and gets locator A and locator B, respectively. MH always monitors the links status and updates the bindings between the MH host ID and locators to the RHB-1. The changes will be automatically propagated to the host realms. The correspondent host (CH) will only know the MH’s host ID and communicate with MH using its host ID. Network translates the ID to the correct locator of the MH. Thus, location privacy is maintained. RHB-1 and RHB-0 form slice-1. The multihoming policy is configured by the host realm owner represented by the RMs. Note that RHB-1 and RHB-0 have separate and independent ID spaces. Hence, achieving multihoming functions does not add any complexity in the inter-domain routing system.

Note the difference from Shim6 [43], though both use variations of ID locator split idea. Shim6 is an end-host based solution, while we intend to build a whole multihoming signaling plane containing functional realm blocks which is much more powerful than the end-host based solution.

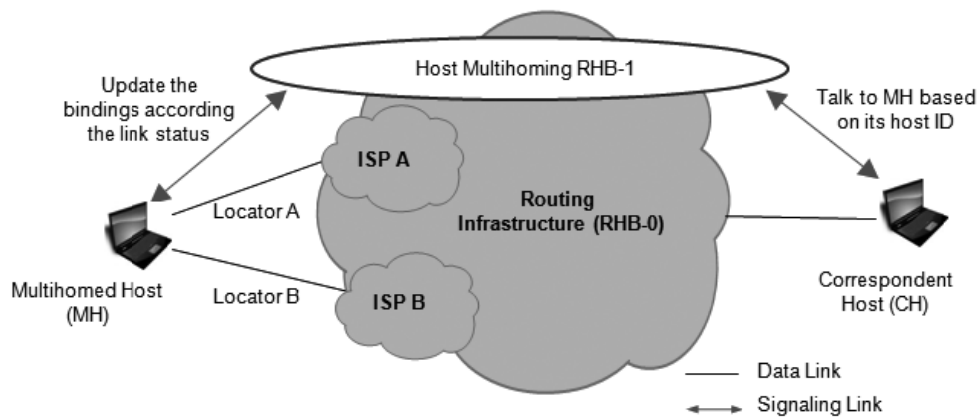

Figure 3.17. A simple host multihoming example

User and Data Multihoming As discussed above, the key to support user and data multihoming is to create the virtual “multi-attachment”. In our framework, we achieve this goal by

decoupling the ID and locator semantic and creating “realms” to manage the IDs. We generalize it to user and data realms above the host realms and create dynamic binding and mapping across different tiers just like what is achieved for the host multihoming solution [8].

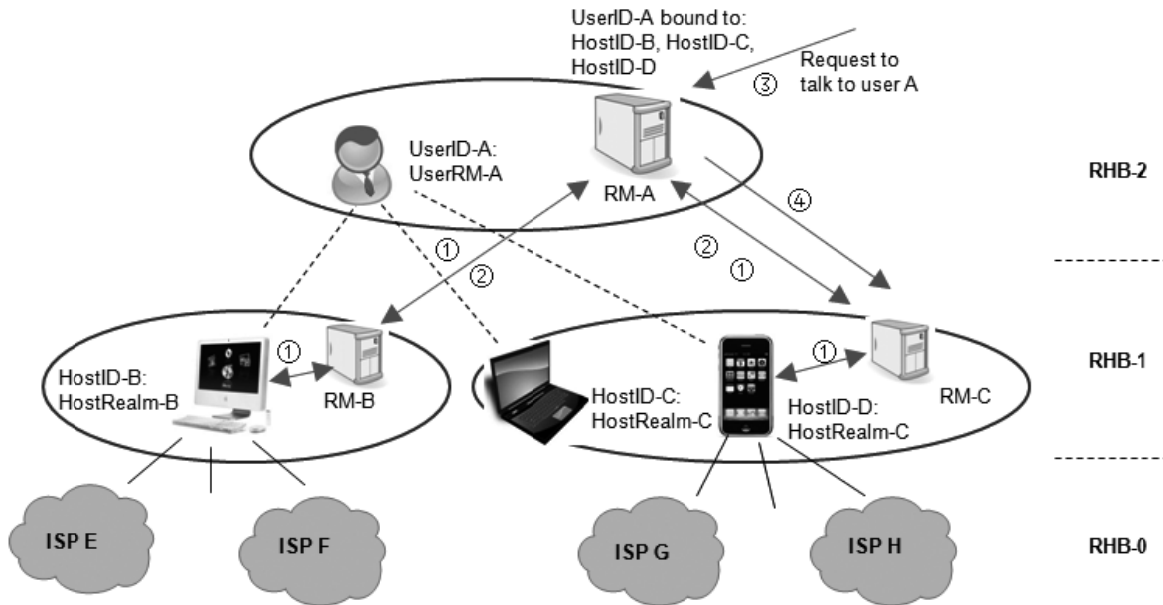

Figure 3.18. A simple user multihoming example

We illustrate how the user multihoming works by simple example shown in Figure 3.18. A user has three end-hosts. The desktop (host B) in his office is owned by the company and is in company host realm B, while the laptop (host C) and iPhone (host D) are the user’s private properties and are in private host realms C. He uses the desktop and iPhone simultaneously for some coordinated service (e.g., Photo Stream app that pushes photos to user’s all apple devices). Each end-host belongs to a host realm and is managed by a realm manager (RM). RM-B and C manage the end-hosts in their realms and are in charge of the host multihoming function. They also talk to the RM-A of the above user realm to achieve user multihoming. For the step ① shown in the figure, the end-hosts update their host ID information with the local host RMs and then report to the user RM. The user RM keeps a copy of up-to-date binding information for the users and its bound hosts. In this example, the user initially uses the desktop and iPhone at the same time for some service, and then switches to use the iPhone only. As step ② shows, the user RM updates the bindings to reflect such changes. After that, whenever outside correspondents want to talk to the user, the requests will be forwarded to the iPhone directly (step ③ and ④) and the service for the user is without any interruption in

case of any end-host fail or service handover initiated by the user. This example is only about user multihoming; data multihoming is similar to this procedure.

3.9.5 3D Multihoming Framework and Related Issues

After the above simple example, we discuss the framework in a larger scale in Figure 3.19.

(1) 3D Framework

The 3D model consists of three dimensions: hierarchy, layer, and slice. The RHBs comprise of new realms related to each other for specific multihoming function. For example, RHB-1 comprises of host realms which help build host-to-host trust, security, or connection based relationships. RHB-1 has multihoming specific function based upon RHB-0. A simple illustration of what RHB-N means to RHB-(N-1) is like “RHB-N provides realm ID dynamic binding and mapping for RHB-(N-1) for multihoming purpose”.

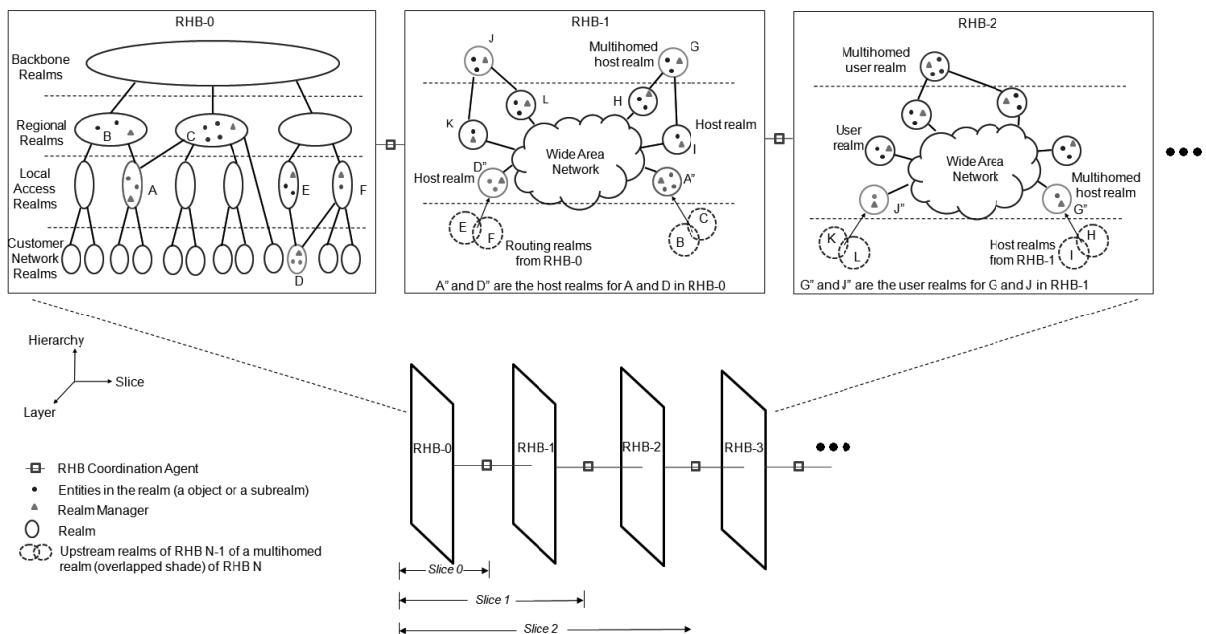

Figure 3.19. An example illustration of the 3D multihoming framework

The model shows a slice-0, a host multihoming slice-1, and a user multihoming slice-2. It consists of 4 RHBs from left to right while potentially there can be more in the future due to the extensible design. The ellipses and circles in the RHB are the realms hierarchy and the dots inside the realm are the entities under the supervision and management of RMs represented by the triangles. The

dotted circles with overlapped parts in RHB-1 and RHB-2 mean the multihomed realms in which the overlapped part represents the realms in RHB-N are bound to the two realms in RHB-(N-1) for multihoming. Figure 3.19 considers only 2-homed cases but in general, there can be multiple homes. For each RHB-1 and RHB-2, the inside realms are also hierarchical as in RHB-0. Between two neighbored RHBs, there is a “RHB Coordination Agent” (RCA) which interacts with all the elements in a RHB and is responsible for the coordination with other RHBs. It also provides interfaces for interaction.

The RHB-0 in Figure 3.19 illustrates two multihoming cases: (1) realm A, which is a local access realm, is connected to two different regional realms B and C; (2) customer network (stub network) realm D is connected to the two different local access realms E and F. Case (2) is called stub Network Address Translation (NAT) multihoming in survey [89]. Then we build new RHBs to enable a flexible host and user multihoming in a way that will not negatively affect others in the Internet. Thus, in RHB-1, the host realms are logically connected (they may connect to each other through logical links or through a central intermediate agent). The host realm D” represents the host realm of the customer network realm D which is multihomed to two local access realms of E and F. The overlapped dotted circles and the arrow pointing to the host realm D” represent the multihoming in RHB-1. Hence there is a hidden underlying binding between the host realm D” in RHB-1 and the realm D in RHB-0, and the binding and interaction is done through the RCA between RHB-0 and RHB-1. Host multihoming is achieved through the dynamic binding between host realm and customer network realm and the cooperation among RHB-0, RHB-1, and RHB-2. Similarly for the multihomed host realm in RHB-1, there is a corresponding user realm in RHB-2 to realize the dynamic mapping and binding between RHB-1 and RHB-2. Multiple RHBs are then assembled to form the complete slices by using RCAs as the intermediate agents.

In the model, Slice-(N-1) multihoming is conceptually characterized as **realm overlapping** in the slice-N and can be achieved by dynamic mapping delivery and update in slice-N. This applies to all types of multihoming.

(2) RHB Mapping and Caching Mechanism

In our framework, the dynamic binding between the ID spaces need to be retrieved and updated quickly and cost-effectively. The original DNS system was designed for static mapping and cannot handle such frequent updates. Also, for the users, they may have different demands on re-homing

frequency and it is a waste to provide the same service for those who rarely change their mappings. So we have a mapping structure that provides differentiated and customizable service. We classify all the customers into several categories based on re-homing frequency. We then structure the mapping realm managers (RMs) in a specific RHB into a hierarchy with a hybrid “push/pull/caching” mechanism. As shown in Figure 3.20, the RMs with different update rates interact with each other to keep the mapping data up-to-date. Moreover, these RMs will serve with different priorities to the customers of different classes. Top mapping servers keep the most up-to-date binding by pushing from the outside. Middle mapping servers update their local copies of the bindings from time to time by pulling data from the top servers. The bottom servers have even lower update rates. The lookup speed can be very high with caching mechanism.

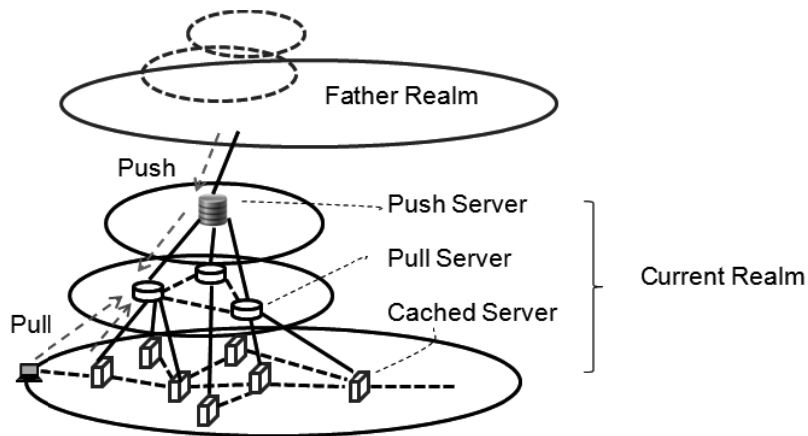

Figure 3.20. Hybrid push/pull/caching mapping delivery

(3) Multihoming ID Structure and Aggregation

Building extensible slices means that the newly created ID spaces are routable in the slices for ID scalability in that slice just as the current IP prefix-based routing in the Internet [86]. Currently, flat IPv4 or IPv6 addresses are used by some solutions as the EID (Endpoint ID). They lack EID aggregation in the mapping overlay. Therefore, we try new designs for the host-ID which include hybrid ID format and ID aggregation. It is an enhanced version of our prior MILSA ID [1] with tree structure combined with a hierarchical part for the logical affiliation inside the host realm and the flat cryptographic part similar to the current Host ID in the HIP [42] for security. This way, the closer the hierarchy of mapping system is to the hierarchy of the host realm, the more benefits in scalability, ease of policy enforcement and management, and host multihoming.

3.9.6 Discussions

In this section, we will present some analysis and discussions.

(1) First-Step Deployment Benefits

The existing multihoming practice contributes a lot to the current routing scalability issue. The first step in deploying the new architecture is to decouple host realm from routing realm and create an infrastructure of slice-0 to support future slice-1 and 2 deployments for user and data multihoming. One of the benefits of our framework is that the deployment of this first step for host and AS multihoming can alleviate the routing scalability problem by reducing the total inter-domain routing table size. We do a preliminary evaluation of this effect based on the approach we used in our previous work [8]. Currently, both the number of multihomed ASs and the prefixes they announce in the routing table are increasing approximately linearly (8.45% annual increase every year). In our evaluation, we consider two cases: first, deploying in 10% of these multihomed ASs every 6 months and finish the whole deployment in 5 years; second, deploying in 20% of these multihomed ASs every 6 months and finish the whole deployment in 2.5 years. We estimate that with the deployment, the total prefixes contributed by the multihomed stub-ASs can decrease significantly depending on various deployment speeds. Specifically, for the first case, the prefixes for the multihomed ASs decrease from around 90K to 30K in 5 years in which case the prefixes announced by them are very close to 1 prefix per multihomed AS, i.e., the low bound. The second case takes almost 2.5 years to achieve the same results.

(2) How Design Principles Are Reflected in the Framework

(a) *Evolution and Coexistence*: The new framework is built upon the current Internet and protects the existing investment. It is different from many other clean-slate designs which ignore the practical deployment constraints for the current Internet. Due to this feature, the framework is backward compatible and the coexistence of the new and old technique and equipments will be a norm during the evolution process of the architecture.

(b) *Incremental Deployment*: The deployment of realms and slices in the new framework are incremental based on the existing Internet. The first step can be decoupling of host realm from routing realm and create an infrastructure of slice-0 to support further slice-1 and 2 deployments for user and data

multihoming. Every step of the deployment results in incentives by protecting existing investments along with providing new services without disrupting the existing services.

(c) *Organizational Control*: The incorporation of realm and RMs enable the framework to perform organization control for data and user which is currently missing in the existing Internet architecture. The user and data level policies are no longer mixed and conflated with routing policies as in the current routing system. More high level features like security, finer-grained policy control, and content base services become possible in the new framework.

(d) *Location Privacy*: In the new framework, the locator based routing system is liberated from the above business policies. The user and data multihoming are performed by separate new ID spaces. Location information of the user is transparent to the correspondents who only know the IDs for communications.

3.10 Short Summary

In this chapter, we discussed the general framework of MILSA architecture based on ID Locator Split concept addressing multiple research challenge of the existing Internet. It differentiates two dependency relationships which are usually confused in the current Internet architecture. It also enables trust and policy boundary comparing with the perimeter based boundary in the existing Internet. We further discussed a series of design enhancements to the naming and mapping mechanism in the new architecture, which fits the new solution to a series of design goals specified by the RRG of IRTF. Transition mechanisms from the current Internet to the future are presented and discussed in this chapter

Chapter 4

Evaluation and Analysis for Routing Scalability and New Internet Architecture (NIA)

In this chapter, we focus on our major work on the evaluation and analysis of the inter-domain routing system for routing scalability and future new Internet architecture design and deployment. The content of this chapter is based on two of our publications [8, 9].

4.1 Introduction

The issue of routing scalability comes from the fact that the size of the inter-domain routing table is increasing very fast during the last couple of years and the trend is very close to an exponential increase. It is one of the most urgent challenges for the future Internet architecture. Routing scalability issue due to the expansion of the global routing tables was initially alleviated by progress in hardware technology and Classless Inter-Domain Routing (CIDR) [86]. However, for multihoming, traffic engineering, and renumbering benefits, address aggregation rules for scalable routing are often disregarded. More users are using the PI (Provider Independent) address space more like an “identifier” than a pure address, which breaks the address aggregation rules for scalable routing and has pushed BGP routers in the Default Free Zone (DFZ) to their capacity limit. However, ISPs may face different technical or economic constraints in upgrading their hardware devices. Also notice that the size has other implications such as bigger update churns, longer convergence time, and routing instability. Two new trends of the Internet may make things worse: one is the new IPv6 address space and the other is that potentially billions of mobile small-sized handheld or even “smart dust” hosts are expected to connect through Internet (so-called “Internet

of Things” [98]). Moreover, the scaling problem also leads to other challenges related to security, control, and management. From the architectural design perspective, it is also broadly believed that the overloaded IP address semantics of “identifier” (ID) and “locator” is one of the major reasons for the scaling problem [1].

Thus, there are two goals of this chapter: (1) to present the real status of the global inter-domain routing system through systematic evaluation and analysis, and the results are supposed to provide useful insights for future routing system improvements as well as designs and implementations related to future Internet architecture; (2) evaluate and find how various incentives and strategies will affect the deployment of a new architectural solution. For (1), we define a series of quantitative metrics that can potentially unify results from several measurement projects using different approaches, and can be an intrinsic part of the future Internet architecture for monitoring and evaluation. We systematically evaluate the current inter-domain routing system and reveal many “Autonomous System (AS)-level” observations and key lessons for new Internet architectures. With these findings, for (2), appropriate deployment strategies of the future architecture changes can be formed with balanced incentives for both customers and ISPs. The results can be used to shape the short-term and long-term goals for new architectures that are simple evolutions of the current Internet (so called dirty slate architectures) and to some extent to clean-slate architectures.

4.2 Related Work

In this section, we discuss some related work.

4.2.1 AS-level Measurements

We are not the first to do AS-level analysis. Actually, in the last decade, many papers have used the public BGP data sources to analyze the Internet for different purposes such as Internet topology [99, 100], routing table size growth and prefix aggregation [52, 68, 101], etc. Roughan, et al. [102] summarize the AS-level measurement work of the last 10 years and clarify many controversial observations; the authors also argue against many "exercises-like" AS-level topology measurements. The authors advocate measuring the AS Internet as an economic construct driven by economic incentives and constrained by socio-technological factors instead of just uninspiring abstract graphs. Our work matches this call well.

Though some overlap with some earlier AS-level analysis is unavoidable, our approach is novel because: (1) we do it in a different way and for different purposes, i.e., we do it in the context of deploying new architectures and estimate how various deployment strategies can achieve different results; (2) we set up a system of new metrics and study their boundary values for monitoring deployment progress and maintaining cost-effectiveness. We aim to shape short-term goals like routing scalability and long-term goals like new architecture evolution.

4.2.2 Schemes for Aggregation or Different Conceptual Routing

This category of related work is same as what has been discussed in Subsection 3.2.3. More detailed discussions in this aspect can be found there.

4.2.3 Work on Scalability and Future Internet Architecture

Despite the debate over the severity of the address deaggregation [103] and the argument that hardware technology advances can make routing table size expansion issue unimportant [104], routing scalability is still one of the direct incentives (though not the only one) motivating the Internet community to look for architecture alternatives [1]. Routing Research Group (RRG) [47] of IRTF and HIP [42] and LISP [44] groups of Internet Engineering Task Force (IETF) have been working on several solutions. A low-cost transition solution to improve the prefix aggregation is presented in [55].

Many research efforts have been recently initiated like Future Internet Design (FIND) [19] and latest synergistic Future Internet Architecture (FIA) program [18] from U.S. More details of these and other global architecture design and experimentation efforts can be found in our papers [3, 4].

4.2.4 How They Are Related to Our Work

First, new architecture ideas need more knowledge about the latest status of the Internet and about evaluation methods for deployment. Second, non-technical incentives and deployment strategies analysis are needed for solving the routing scalability issue and for long-term architecture evolution. Hence, these two aspects illustrate our unique goals and contributions: (1) to provide systematic evaluations on the real-world status for deployment reference, and (2) to provide incentives and deployment strategies analysis for NIAs.

4.3 Methodology

Internet is too complex and there is not a single place that can claim having a complete copy of raw data characterizing the "whole picture" of the Internet. Hence, to avoid or limit the chances of biased information, we combine several public inter-domain routing data sources. The three data sources we used include: CAIDA [105], Route Views [106], and CIDR Report [101]. They have different features and we use them for different purposes. We also carry out cross-comparisons among these sources to validate the results and observations. For incentives and deployment strategies analysis, we combine the data sources to get a clearer picture of the many factors that can impact any new architectural deployment. We evaluate how the different incentives and deployment strategies lead to different results in achieving short-term as well as long-term goals. The features, comparison, and modeling usage of the three data sources are listed in Table 4.1.

Table 4.1. Data sources used in our evaluation and analysis

	Route Views	CAIDA	CIDR Report
Features	Long-time logs of routing data, peering with multiple big ISPs' ASs	Provides pre-processed topology data	Multiple granularities statistical data, latest changes, summary, etc.
Comparison	Full record of a long period of time	Some results relatively old	Most up-to-date data and trends
Modeling Usage	General size estimation, trends estimation, raw data for further processing	Estimation of prefix aggregation trends (metrics APAR and RPAR), and deployment strategies and effects	General AS prefixes, BGP updates, Aggregation Ratio (AR), CAR estimation

Our evaluation is based on AS-level analysis. Though there are limitations of such methods for other measurement purposes [102], we find it useful in our evaluation for new architecture research. Though AS is always deemed as only a basic routing unit, it is also a basic organizational unit, which is overloaded with both inter-domain routing policy and high-level business relationships [8] (indicating cash flow of customer-to-provider and provider-to-provider relationships). These later parts and the real incentives for the stakeholders are always overlooked. Much information is hidden among the interaction of the ASs and we want to reveal it through quantitative evaluation. We believe such methods can reveal significant organizational information for the future Internet. These

concepts about ASs were also reflected in our MILSA architecture [5] and policy-oriented frameworks [78].

In this work, we define unified quantitative metrics to evaluate the current status. Some evaluations have used different approaches on different data sources and may have drawn biased conclusions. Using a unified metrics can help mitigate such errors and form a complete view of the current Internet by integrating different measurements. Also, for new architectures, a quantitative metrics system integrated into the architecture is necessary to monitor and control the Internet. Our effort can be a good starting point for this. Moreover, we try to avoid the mistakes made by several previous BGP data analysis papers that only look at the data without identifying the structural components that cause the observations. Hence, in the evaluation for each metric, in addition to analyzing the data, we have observations and key lessons discussions in the context of NIAs, which is one of the key goals of our work.

4.4 Future Internet: Deployment Incentives and Strategies

In view of the debate regarding the future architecture to be a clean-slate or an evolutionary one [28], in this section, we focus on evolutionary ones since we believe that today's Internet is too big to be started over again.

4.4.1 Deployment Incentives

We do a detailed evaluation in the next section to address the problems faced in the context of both routing scalability and future Internet evolution. However, every change needs balanced incentives and motivations for ISPs and customers. This also applies to the transition to any potential new architecture. For deployment, it is necessary to have a clear strategy which balances the interests of all parties and sets up a “win-win” business model in the technical deployment plan. After a thorough investigation, we summarize the incentives into three categories: (1) privacy and *mobility* that the new solution can provide for a single user or a group of users; (2) *multihoming, traffic engineering, easy-renumbering*, and (3) *scalability*. Users or ISPs may have different priorities and preferences in achieving these under certain cost constraints. End-users expect to pay only for the features they need instead of all available features. ISPs are more concerned with protecting their

investment and being as efficient as possible. For example, the broad usage of Provider Independent (PI) addresses [1] for stub ASs (for portability, multihoming, and load balancing, etc.) put high burden on the BGP routers in terms of routing scalability. The ISPs have to keep upgrading their core devices to keep the network running. In general, they may prefer to accept solutions that are backward compatible.

In short, we need to balance such incentives and use appropriate strategies to motivate the deployment. Though there are many new architecture ideas available, LISP [44] looks close to the real deployment. Hence we use it as an example for some evaluations in this section. However, our approach and findings are not restricted to LISP and are applicable to any potential NIA.

4.4.2 Deployment Strategies

Customer ASs and ISP ASs play different roles in the routing system which means that various deployment orders can lead to different results. Specifically, with the defined metrics and the evaluation results (Section 4.5.3), we can devise multiple cost-effective deployment strategies that fit the demands and incentives of end-users and ISPs best. Sample conceptual deployment strategies are as follows:

Bottom-up Strategy First deploying functional devices of the new solution for the stub customers' ASs, then the small and medium-sized ISPs, and finally at the big ISPs. Multihoming, traffic engineering, and renumbering are the major incentives. Stub customer's ASs may prefer this strategy due to their motivation of improving these services.

Top-down Strategy First deploy the new solution at the edge of the big ISPs, then the medium and small-sized ISPs, and finally at the stub customers' ASs. Mobility is the major incentive since both end-user and big mobile service ISPs have demands for this. Mobile customers and big ISPs providing mobility services may prefer this strategy.

Middle-way Strategy First deploying for the medium and small-sized ISPs, then toward the two ends. The major incentives is routing scalability because medium and small-sized ISPs have more motivation to protect their current investment and may not be able to or be willing to catch up the pace of hardware upgrades.

Adaptive Strategy The deployment priorities are based on a selected set of metric values and criteria. The incentive is a balanced combination of different factors. The deployment order is decided by balancing the priorities of all ASs.

We summarize the enhanced strategies and incentives, the major motivators, and the deployment priorities in Table 4.2. We further evaluate how these strategies impact the Internet

Table 4.2. Deployment strategies: their incentives, major motivators, and deployment order

	Top-down	Bottom-up	Middle-way	Adaptive
Incentives	Mobility	Multihoming, Traffic Eng., Renumbering	Scalability	Composite
Motivators	Mobile ISPs, especially big Mobile ISPs	Stub Customer ASs	Medium, Small ISPs who need investment protection most	ASs that have highest scores based on an evaluation standard
Deployment order	Big ISPs → Medium, Small ISPs → Stub ASs	Stub ASs → Medium, Small ISPs → Big ISPs	Medium, Small ISPs → Big ISPs or Stub ASs	ASs with High Scores → ASs with low Score

4.5 Evaluation and Analysis

This section covers: (1) basic evaluation on BGP Routing table, its size and contributors, and prefixes; (2) quantitative metrics definition and detailed evaluation, (3) evaluation of various deployment strategies using the new metrics, and (4) metrics' boundary values evaluation for monitoring deployment progress.

4.5.1 Basic Evaluation: BGP FIB Table and the Prefixes

(1) Routing Table Size and Its Contributors

Firstly, we simply calculate the rough routing table sizes based on the number of prefixes. We found that it is increasing very fast. Specifically, the total prefixes size has increased by 6 times during the last 12 years (from 52K in 1998 to 301K in 2009), and there is about 20% increase every year. The exponential increase brings a series of impacts to the inter-domain routing system. For example, it can lead to longer BGP convergence time, more signaling traffic, more memory to store the routing table, more CPU (Central Processing Unit) computation capacities, and even more power consumption and heat dissipation from the routers. It also makes it difficult to keep the whole system consistent. Conceptually, it would become even worse in the perspective of future IPv6 world in which millions of nodes are expected to connect to the Internet.

The exponential increasing trend of the size of the inter-domain routing table has been observed [52, 53] for long time. The underlying reasons are complicated [68]. To illustrate the different factors and contributors leading to the expansion of the inter-domain routing table size growth, we summarize the problem space by the following formal equation:

$$S \propto f [B * T * Deagg (A, P, M, TE, AF)] \quad (4.1)$$

Here,

S: Size of the global routing table

B: Base size of the routing table entry

T: Topology complexity of the network

A: AS domain complexity

P: AS domain policy factor

M: Multihoming factor

TE: Traffic engineering and load balancing factor

AF: Address fragmentation factor [68]

The function $Deagg()$ reveals the influence of the address disaggregation due to miscellaneous contributors in the current Internet which weakens the CIDR effects.

(2) AS/Prefixes Distribution and Topological Aggregation

To present an overview of the difference among ASs, we do a coarse analysis based on a sample by using the approach of Dimitropoulos [107]. The result is shown in Figure 4.1. From the figure, we observe that the stub-ASs cover about 65% of the total ASs available in the Internet, and about 0.4% percent of the ASs are transit-only ASs (tier-1 ASs mostly). Another 30% of the ASs are tier-2 ASs which provide some level of transit. The remaining is indiscernible due to the algorithm limitation and the complexity of the routing system. However, for the prefixes announced by these ASs, 70% of the total prefixes are contributed by the tier-1 and tier-2 service providers, and 20% are contributed by the stub-ASs (again, the remaining 10% are indiscernible). Another important observation of the Figure 4.1 is that the ratio of the number of prefixes to the number of ASs for

ISPs is significantly bigger than that of the stub-ASs. Hence, we conclude that the aggregation of prefixes by tier-1 and tier-2 ASs should be the most important parts for the global routing scalability.

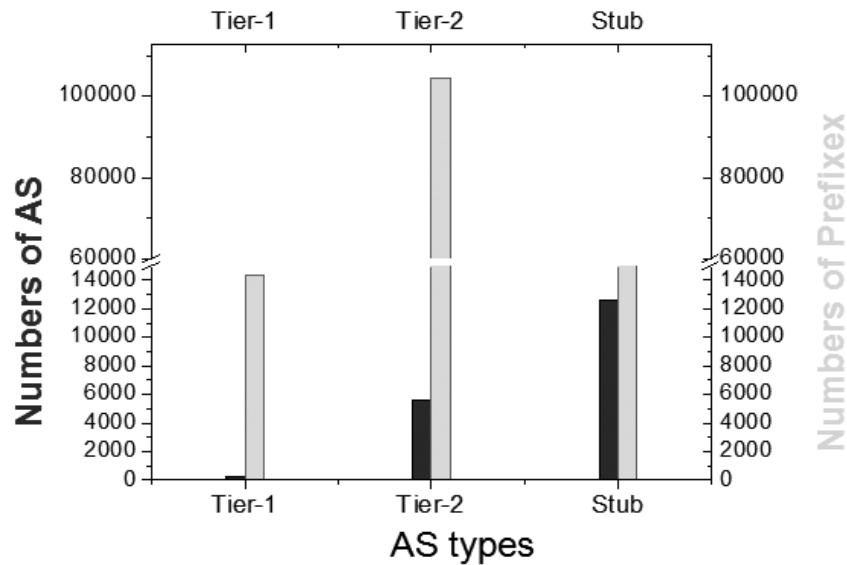

Figure 4.1. AS and Prefix Distribution

We further evaluate the prefix length distribution in the routing table, as well as the increasing trends during the past ten years. We observe that the number of prefixes with length between /17 and /24, especially /24 is the biggest portion and with the fastest growth speed among all the prefixes. This can be explained by the broad usage of the class C addresses in the global routing, and the small and medium sized commercial ASs connected to the Internet with increasing requirements on multihoming, load balancing and routing policy enforcement which tamper the prefixes aggregation.

About improving aggregation, we also notice the evaluation results in [68] that the address fragmentation constitutes approximately 75% of the disaggregation of the prefixes. Our latest evaluation confirms the continuance of this trend. The topological aggregation rule so far is hard to be realized by the current addressing and routing system. However, the depletion of IPv4 address space also means that the total size can be bound. IPv6 can be a huge challenge for scalability without better aggregation. We argue that although the transition from IPv4 to IPv6 can be a pain, for MILSA, it is also a great opportunity to construct an IPv6 core with all the locator strictly topologically aggregated and with the help from efficient automatic address allocation technologies. As indicated in [82], IPv6 prefixes so far are well aggregated. Given the fact that the IPv6 locator

space is big enough to accommodate future expansion, the 75% disaggregation due to fragmentation can be avoided.

4.5.2 Autonomous System (AS) and Aggregation Ratio (AR)

(1) AS Imbalance and Its Implication

We use the metric of Aggregation Ratio (AR) to evaluate how well a specific AS performs aggregation inside itself. Detailed AR definition and description is in the next subsection (Subsection 4.5.3). To observe the distribution of ARs among different ASs, we first put the cumulative AR of the total AS space as X-axis (ranging from 0 to 1), and select out all the AS numbers that have higher ARs than the designated AR ratio.

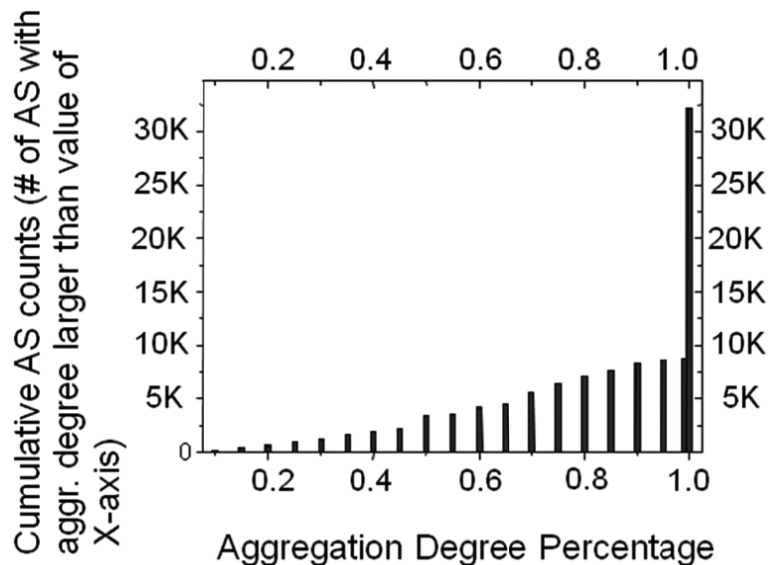

Figure 4.2. Cumulative ASs count (# of ASs with aggregation degree larger than the value of the X-axis)

The result is shown in Figure 4.2, and we can observe that about 1/4 of the total AS space (about 8,726 ASs) share a pretty even aggregation distribution between 0 and 1, the other 3/4 of the total AS space has the AR of 1 because most of them are small stub networks that announce only one prefix in the global routing table. Moreover, among the 1/4 of the ASs that announce more than 1 prefix, their cumulative percentage of AR and the AS count approximately match the linear trend which indicates that this portion is mostly the miscellaneous transit ASs (or ISPs) that do the aggregation of their customers and announce the prefixes to their upstream providers.

In Figure 4.4, however, we demonstrate the relationship between prefixes announced and the corresponding AS counts. We sum the prefixes announced by each AS and sort them by the number of prefixes they announced in a decreasing order. The distribution trends reveal a significant imbalance among these different ASs. Specifically, the top 5% (1,500 out of 32,141) ASs announced 60% (183,881 out of 301,659) of the total prefixes. The top 30% (9,000 out of 32,141) ASs announced almost 90% (263,267 out of 301,659) of the total prefixes. As a rough average, every AS contributes 9 prefixes to the global routing table. Moreover, we sort the ASs according to their AR in increasing order and calculate their cumulative AR. The results are shown in the Figure 4.3. The cumulative AR ranges from 0.44 for the top 50 ASs to 0.61 for all the 32,141 ASs. Again, this result is consistent with what we observe in Figure 4.4.

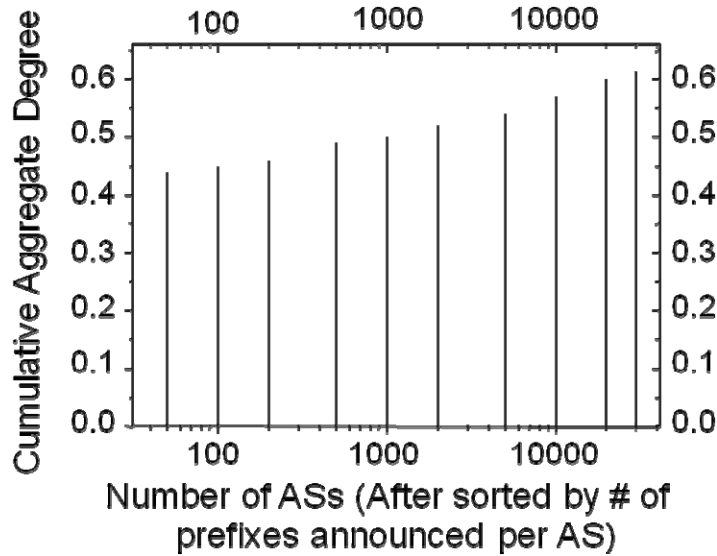

Figure 4.3. Top-N ASs and their cumulative aggregation degree (ASs are sorted by their prefixes announced)

Since the top ASs mostly are transit-ASs or stub-ASs with more prefixes announcements and lower AR. Thus, we argue that for potential short-term solutions (such as Virtual Aggregation [54, 55]) aiming to resolve the aggregation and scalability issue, these transit AS with more prefixes announced and with lower AR should be considered with higher priority than the other ASs. This is one of the deployment strategies of our MILSA solution.

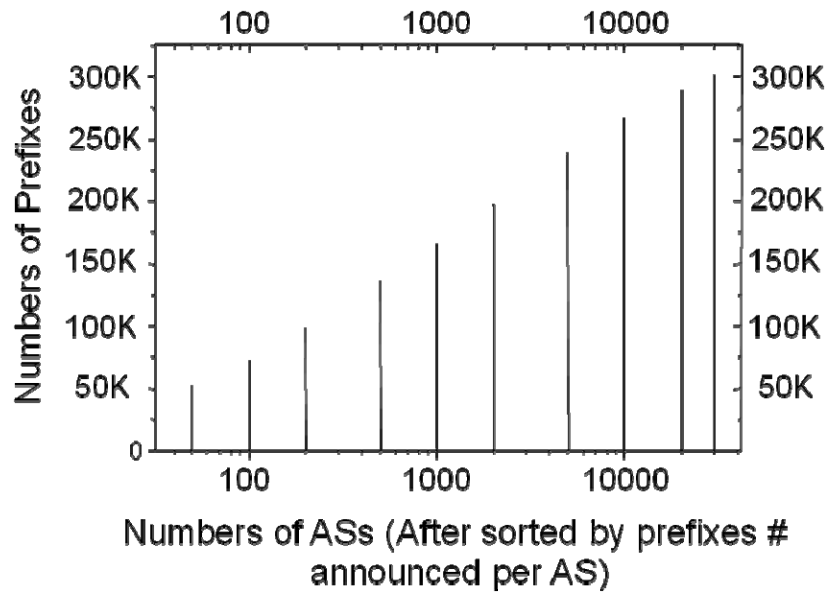

Figure 4.4. Top-N ASs and their cumulative prefixes announced (ASs sorted by their prefixes announced)

(2) AS semantic overloading

The failure of achieving acceptable aggregation for these top transit-ASs mostly is due to reasons we observed in Subsection 4.5.1. However, from the architectural design perspective we also argue that one of the deeper underlying reasons is “AS overloading” as we name it. The AS concept is mainly used as a domain of connectivity in the current inter-domain routing system. However, we notice that AS is basically a group concept among organizations due to commercial connection or dependency. This overloading makes the configuration and management of the domain policies very awkward and inconvenient. The efficiency and consistency of the inter-domain routing is also impaired. Solutions, such as RCP [72], try to ease the configuration and management in the AS by centralizing policy and path selection decisions. However, RCP doesn’t change the fact that the AS is still overloaded and the two different levels of domain policies are still mixed together. One of the most direct benefits of performing the separation is the easiness of applying routing policies and performing routing domain federation. Moreover, AS number and prefixes are the two different aggregation granularities that inter-domain routing system is based on. However, the fact is that the AS number in BGP is not a significant factor in improving the aggregation of the global routing table. Given all these temporary or short-term solutions attempting to improve the aggregation, we argue that without the presence of a complete separation of the overloaded semantics of AS, the

scalability, configuration and management issues will go on in the future, and ID locator split solutions such as HIP [42] and LISP [44] themselves may not be enough for long-term evolution. In even longer term consideration, to prevent future potential ossification, two tiers may not be enough, thus we may need to divide them in more granularities. In the future, defining good inter-tier and inter-realm interaction protocols and interface are necessary to harvest the above benefits.

4.5.3 Site Multihoming Evaluation

We focus on AS level multihoming, i.e., site multihoming since it has a significant impact on the routing scalability. Since the transit ASs are generally ISPs that peer with more than one other ASs, they are “genuinely and naturally” multihomed. Thus, the multihoming under investigation in this section is that of the ASs around the edge of the networks, i.e., stub networks. To reveal the latest multihoming status, we extract the data from the latest routing table data. We first infer the AS relationships by combining several algorithms [66, 108]. After that, we define several rules to determine if a stub-AS is a multihomed one or not based on the inference results, which include: (a) The AS under investigation should have connection degree greater than or equal to one, (b) The AS under investigation should have at least two upstream providers offering connection, (c) The AS itself has no customer link, i.e., no down-link customer AS, (d) Prefixes announced by the AS should appear in one of its providers’ BGP routing table.

Based on the above rules, we have designed a rough algorithm (Algorithm M shown in Table 4.3) to determine if an AS is multihomed and to calculate the number of multihomed stub networks and record their multihoming degree. We observe that among the total 33,485 ASs, there are totally 28,705 stubs-ASs. Among the stub-ASs, about 40.94% of them are single homed and 54.86% are multihomed (with multihomed degree larger or equal to 2). Notice that in our sample there are 1,204 (4.2%) “dead” ASs that connect to nowhere, which may be because of some on-going configuration or testing. We also computed statistics of the prefixes these multihomed ASs announced. We observe that the prefixes announced by multihomed stub sites constitute about 67% of the total prefixes announced by stub networks and 34% of the prefixes in the global routing table. It is easy to imagine if these portion cannot achieve acceptable AR, the total aggregation of the CIDR can suffer, hence lead to poor scalability of the routing system.

Table 4.3. Algorithm M to determine multihomed sites

Algorithm M: Determine multihomed sites

- 1: Objective BGP Routing table, denoted T ;
- 2: Get the inference results S by algorithm [66, 109];
- 3: //Get stub-ASs set
- 4: Scan S iteratively to find the ASs with no
- 5: customer ASs;
- 6: Mark the ASs without customer ASs, get set S_{stub} ;
- 7: //Filter out and mark the multihomed ASs set
- 8: Scan S_{stub} set iteratively to find ASs with
- 9: connection degree greater than 1;
- 10: Mark the ASs with the degree number, get set
- 11: $S_{stub}(Degree)$;
- 12: The marked set $S_{stub}(Degree)$ is the multihomed
- 13: stub-ASs set, and the degree number is the
- 14: multihoming degree;

Further details on the comparison of the number of ASs and the prefixes they announced per multihomed degree are shown in Figure 4.5. We can observe that 2-homed and 3-homed cases comprise the biggest parts regarding to the raw AS count as well as the prefixes announced in the global routing table.

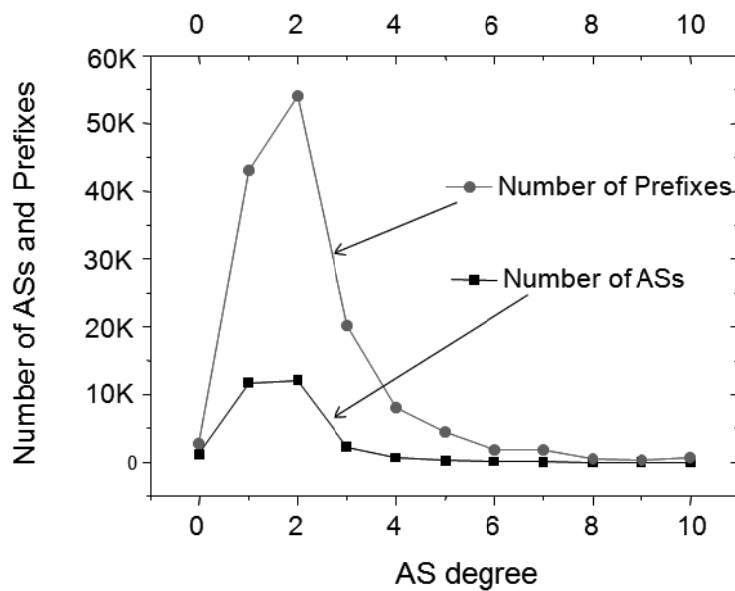

Figure 4.5. Stub multihoming: Number of ASs and Prefixes

Statistical evaluation on the multihoming trends of the last 5 years is shown in Figure 4.6 from which we see that the number of the multihomed stub-ASs has doubled over the last 5 years and corresponding prefixes announced by them has increased by 50%. The underlying implication is that research on how to facilitate the fast traffic switching and even load balancing can be of great interests to these types of stub-ASs. It can also be used for determining the deployment strategies for future potential solutions.

We also realize the limitations of the IPv4 multihoming [41] and the failure of the aggregation in IPv4. In MILSA, we build multi-tier separated and extensible realms upon the fully aggregated IPv6 locator based routing system. Multihoming, load balancing and traffic engineering, and policy enforcements can be conceptually clear and right without any “overloading” semantic difficulties as in the current Internet.

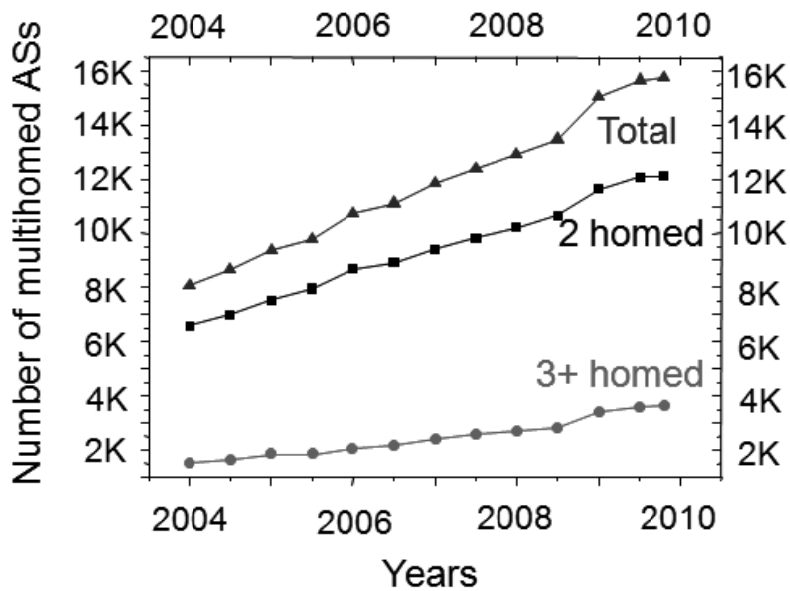

Figure 4.6. Multihoming trends

4.5.4 Deployment Factor: Definition and Implications

Beside the two “macro-routes” we discussed above for the deployment, in a finer-grained scope, the imbalance across multiple ASs also has a significant impact on the deployment effectiveness. Thus, here, we give a coarse equation on all the factors that we should take into account when determining

the priority of each AS deploying our transition mechanism, i.e., deploying the MBR at the edge of the stub-AS.

$$DF \propto f [T, CN, PX, BM, AR, AS, AF, P] \quad (2)$$

Each symbol denote a factor that needs to be taken into account when deciding the deployment priority,

DF: Deployment Factor

T: Type of the AS under investigation

CN: Cone number, the total AS number that acts as customers of the AS, the customer of customer, and so on.

PX: Prefixes announced by the AS

BM: BGP update message rate generated by the AS

AR: Aggregation Ratio of the AS

AS: AS degree of the AS

AF: Address fragmentation degree of the given AS

P: Pain and incentives of the AS

Appropriate weights can be applied to different factors to calculate the final Deployment Factor. Through this equation (2), each AS has a DF which can be used to describe and evaluate the emergency degree of applying the new solution. As observed by [109], different ASs may have different capabilities and motivations to update their devices, and their consciousness and the time they feel pain will also vary. Thus, we also use the factor P to reflect this difference. By balancing all these factors, and applying different weights to these factors, we can design different deployment strategies that fit the practical requirements. For example, some rough rules can be listed to guide the deployment:

- (a) Upgrade the ASs that have most urgent request first,
- (b) Then upgrade those announce the most prefixes,
- (c) Then upgrade those with lowest AR,

(d) Then upgrade those with biggest address fragmentation

The order of these rules may vary according to the real deployment strategies to reflect different considerations.

4.5.5 Quantitative Evaluation Using New Metrics

We start from simple ones and move to the complex ones.

(1) **Prefix Contribution (PC):** the number of prefixes contributed by the AS to the total prefix entries of the “global routing table” (also known as the BGP inter-domain routing table. We will use “routing table” or “table” as abbreviations for the rest of the chapter).

Metric Function: This metric illustrates the overall contribution of an AS to the total routing table size.

Prefixes	ASnum	AS Description
4376	AS4323	TWTC - tw telecom holdin
4122	AS6389	BELLSOUTH-NET-BLK - Be
1858	AS4766	KIXS-AS-KR Korea Telecor
1843	AS1785	AS-PAETEC-NET - PaeTec
1590	AS8151	Uninet S.A. de C.V.
1558	AS7018	ATT-INTERNET4 - AT&T W
1539	AS20115	CHARTER-NET-HKY-NC - C
1453	AS4755	TATACOMM-AS TATA Com
1316	AS2386	INS-AS - AT&T Data Com
1266	AS17488	HATHWAY-NET-AP Hathwa
1206	AS3356	LEVEL3 Level 3 Communic
1133	AS11492	CABLEONE - CABLE ONE,
1113	AS22773	ASN-CXA-ALL-CCI-22773-I
1104	AS6478	ATT-INTERNET3 - AT&T W
1091	AS18101	RIL-IDC Reliance Infocom

Figure 4.7. Top 15 ASs announcing the most prefixes, a sample example

Evaluation: In Figure 4.7, we present a list of top 15 ASs having highest PCs based on a daily-based snapshot from CIDR Report [101] in 2010. We observe that their PCs are much higher than the rest. For example, the AS in the first place has a PC of 4376 while the average PC is 9 for all ASs.

We also evaluate the cumulative PC distribution of all ASs in Figure 4.8 (a data snapshot from 2006). The top 2% (700 ASs) of the total AS space contribute over 50% prefixes while the top 33% ASs contribute over 90% of the total prefixes in the global routing table. The distribution reveals a significant imbalance among ASs which is also close to the so-called “*80-20 rule*” (or Pareto Principle). To verify such imbalance, we further sample a set of prefixes and the BGP update

messages they generate (Note that it should not be inferred that these prefixes are from the top ASs who announce prefixes most) in one hour in August 2009. As shown in Figure 4.9, we observe that less than 5% of the prefixes generate around 80% of the BGP update messages. It roughly matches the above “80-20 rule” and the trend shown in Figure 4.8. More on BGP update dynamics analysis and their relationships with prefixes is in [103].

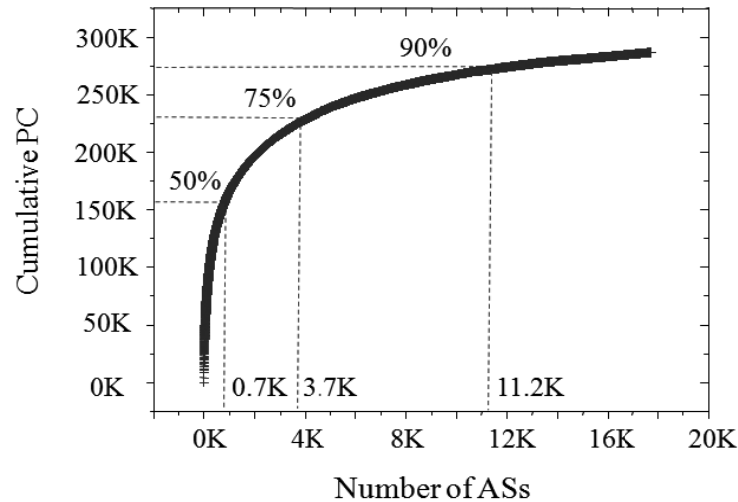

Figure 4.8. Cumulative PC distribution in the whole AS space (ASs sorted in increasing order of PCs)

Observations and key lessons for NIA: From PCs distribution, we can see two types of imbalance in the current inter-domain routing system: (1) between ISPs' ASs and customer ASs, and (2) among ISPs' ASs. It is partially due to the structure of the current inter-domain routing system and because different ASs have different roles in serving other ASs. It means that there is still plenty of room for future improvements. Deploying transitional solution with higher priorities in the ASs with higher PCs may be a good start. For NIAs, the PCs (or its counterpart in the NIA) for an AS should be proportional to the number of customers or actual usage under its territory. It also needs to be monitor-able and controllable from architecture-level supports. Devising such standard metric and allowing comparison among different NIA deployments can potentially help see and evaluate the performance of NIAs.

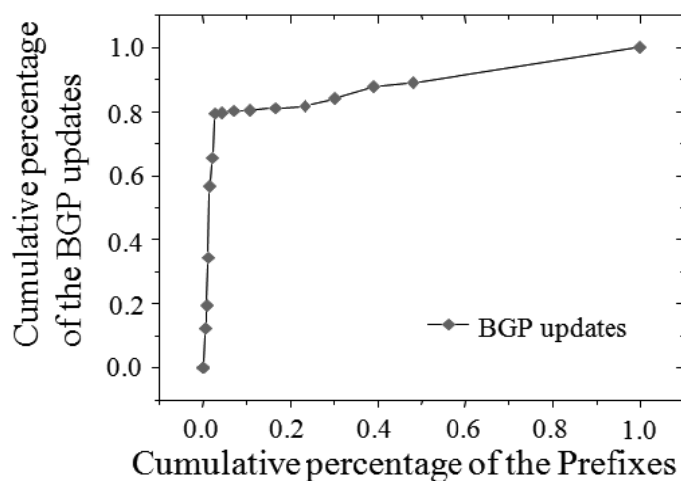

Figure 4.9. A one-hour sample of BGP updates of August 2009.

(2) **Aggregation Ratio (AR)**: the ratio of the number of prefixes announced outside after aggregation inside the AS to the total prefixes announced outside. It is described as:

$$\text{Aggregation Ratio (AR)} = P_a / (P_a + N) \quad (4.2)$$

Metric Function: This metric approximately describes how well a specific AS performs aggregation inside itself.

P_a is the number of prefixes announced outside after aggregation inside the AS, N represents the prefixes the AS gets from its “customer cone” (note: for a transit AS, all its customer ASs and customer-of-customer ASs form a “cone” including the transit AS itself, and we use algorithms and data from [105] for such "cone" evaluation) that are not aggregated. $(P_a + N)$ is the number of total prefixes announced by the AS. However, note that the prefixes are considered “aggregated inside the AS” only when there is a precise match of AS path so that the traffic transit policies are preserved. Also note that the aggregation does not mean perfect or maximum one. We give two examples to illustrate the AR definition and the way to compute it in Figure 4.10. For example (a), $P_a=1$, $N=1$, hence, $AR=1/2$; for example (b), $P_a=1$, $N=0$, hence, $AR=1$. Note the difference between our definition and the de-aggregation factor defined in [103], we focus on the aggregation behavior of an AS along the AS-paths instead of simply using the ratio between number of announced prefixes and allocated blocks.

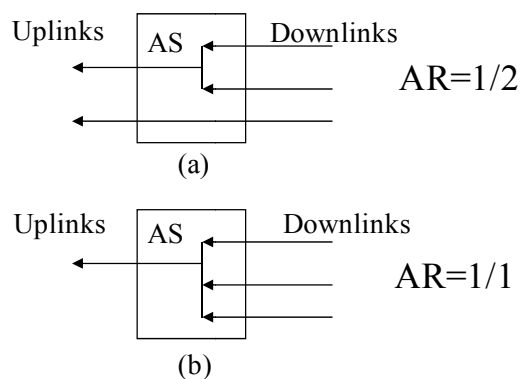

Figure 4.10. Aggregation Ratio (AR) examples

Evaluation: We evaluate the ARs of the 32,125 ASs and sort them in decreasing order by their PCs. The results are shown in Figure 4.11. Interestingly, we observe the symmetric distribution near the horizontal line of $AR=0.44$. The top group with ARs close to 1 represents the stub customer ASs and the dots below it with ARs ranging from 0 to 0.95 are mostly ISPs. We further divide the ISPs into two categories based on the value of $AR=0.44$ and hence we have 3 groups of ARs. Roughly, group 1 has lowest ARs and are mostly big- and medium-sized ISPs; Group 2 consists of mostly medium- and small-sized ISPs who have AR values in the middle; Group 3 are mostly stub customer ASs having ARs close to 1.

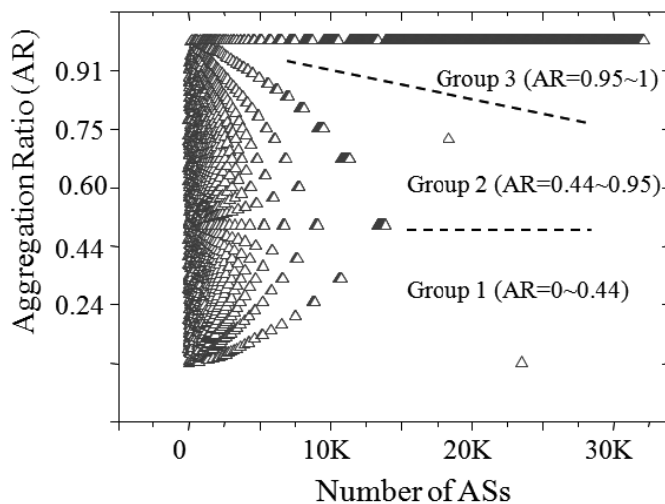

Figure 4.11. AR distribution in the whole AS space (ASs are sorted in decreasing order by PCs)

We then study the numbers of ASs in each group and how much they contribute to the total routing table size. The results are shown in Figure 4.12. Group 1 and 2 (mostly ISPs) only cover 27% of

total AS space but contribute more than 81% of total prefixes in the routing table. Moreover, we observe that big and medium-sized ISPs generally have low ARs, and small ISPs and stub customer ASs have higher ARs due to their location near the edge. In the ideal case, if perfect aggregation is performed, every AS should have $AR=1$. However, in the current Internet, the top 50 ASs with the highest PCs have an average AR of 0.44, and taking all the stub ASs' ARs into account, the average AR of the whole AS space is only 0.61.

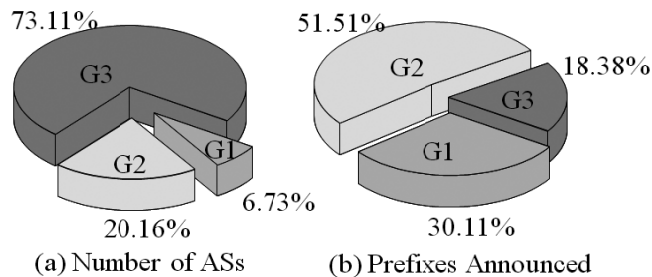

Figure 4.12. Number of ASs and Prefixes announced in groups 1, 2, and 3

Observations and key lessons for NIAs: The aggregation for the current Internet, especially those big ISP ASs is far away from the ideal case due to many factors. Business relationships intermixed with routing protocol may be one of them. Though some hold positive view over the aggregation issue [103], for NIA consideration, especially in near-term when IPv6 has to come, and in longer term of world of "Internet of Things" [98] where smart devices are everywhere, the huge address space and Internet scale makes better aggregation even more important. Separation of multiple level identifier (ID) spaces for dedicated functions may avoid the semantic overloading, and make the aggregation easier and more manageable.

(3) Cumulative Aggregation Ratio (CAR): of a collection of ordered ASs is the ratio of the total aggregated prefixes to the total prefixes in the table contributed by the collection.

Metric Function: This approximately describes how well the collection of ASs performs aggregation inside the collection. Detailed CAR evaluation and improvements for different strategies are presented in the Subsection 4.5.4.

The above metrics are about a single or a group of ASs, and do not reveal the interaction among ASs, especially among ASs in the customer cone. Hence, we have more metrics.

(4) **Absolute Prefix-to-AS Ratio (APAR):** the total prefixes announced by the ASs in the customer cone of the AS. It can be expressed as:

$$\text{APAR} = \sum (\text{PC})_{\text{cone}} \quad (4.3)$$

Metric Function: The *metric* approximately describes the position of the AS in the AS hierarchy and how well its customer cone performs aggregation.

Evaluation: Note the difference with PC. APAR is the sum of the PCs in the customer cone. The higher level the AS is located in *the* AS hierarchy, the bigger the APAR it generally has. For example, in our data sample, AS 1239 (Sprint) has APAR of 263,628, while AS 2552 (Washington University) has APAR of 62. We also study the APAR distribution among the whole AS space which is shown in Figure 4.13. There are very significant differences among the APARs of the three categories (backbone, middle, and stub).

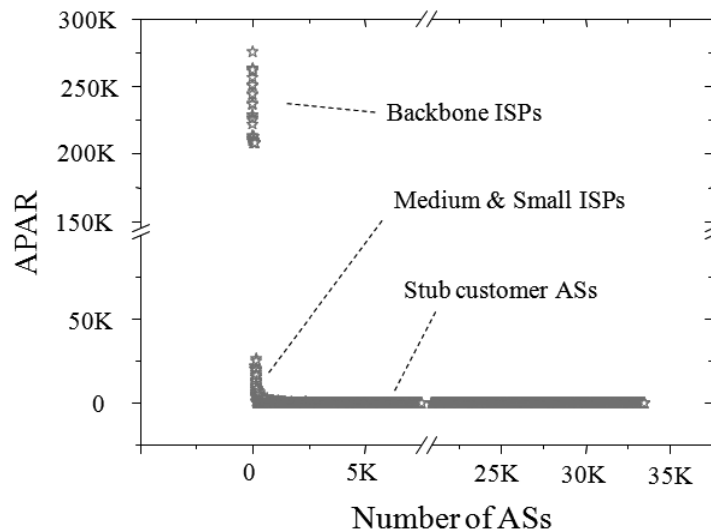

Figure 4.13. APAR distribution in the whole AS space (ASs are sorted in decreasing order by APARs)

Observations and key lessons for NIAs: Compared with AR, the metric of APAR is a more straightforward and accurate reflection of the target ASs' position in the AS tree. Bigger APARs generally reflect poorer aggregation in the customer cone. However, it cannot reflect the exact impact of the customer cone to the target AS, and needs other metrics. For example, for two ASs with the same APAR, we cannot easily tell which one does aggregation better. We use RPAR to help depict the inside aggregation status. For an NIA like MILSA [5], an AS is also an organizational

business management unit besides a basic routing unit. The business level policy is separate from the routing and packet forwarding. The APARs distribution can be a lot more balanced. By dedicated control and management planes, an AS will have stronger interactive capability with its customer cone to keep the overall routing balanced and scalable.

(5) Relative Prefix-to-AS Ratio (RPAR): the ratio of the total unique prefixes announced by the AS's customer cone to the number of total ASs in the cone:

$$RPAR = \Sigma (PC)_{\text{cone}} / \Sigma (AS)_{\text{cone}} \quad (4.4)$$

Metric Function: This **approximately** depicts the average aggregation status in the customer cone.

Evaluation: Intuitively, smaller RPAR means better average aggregation in that customer cone. For example, AS 1239 (Sprint) has RPAR of 9.4 and AS 2552 (Washington University) has RPAR of 62. Washington University is announcing prefixes more than the average. However, we may draw wrong conclusion if we see RPAR only. We know that Sprint is a big ISP and its customer cone included a lot of downstream ASs hence the RPAR of 9.428 is an average number. To explore the inner relationship between APAR and RPAR, we take the top 15 ASs in Figure 4.1 and **compare** their APARs and RPARs. The results are shown in Table 4.4. It shows no absolute linear relationship between APARs and RPARs. Instead, there is a very obvious variation among the RPARs of different ASs. The variation means that even for two ASs with the same APAR, their RPARs can be significantly different due to the complexity inside their customer cone. We further study the RPAR distribution among the whole AS space as shown in Figure 4.14. Compared with APAR, it exhibits a little fluctuation for the ISPs part which is mostly due to the complexity inside ISP ASs.

Table 4.4. APAR and RPAR for the top 15 ASs with highest APAR

	AS4323	AS6389	AS4766	AS1785	AS17488	AS7018	AS8151
APAR	4313	4178	1836	1736	1553	1497	1477
RPAR	9.44	30.77	9.42	9.37	1553	9.61	17.08

AS20115	AS6478	AS2386	AS4755	AS3356	AS11492	AS22773	AS9583
1472	1396	1289	1232	1220	1120	1095	1095
11.67	1396	147	9.42	9.45	1120	9.35	47.77

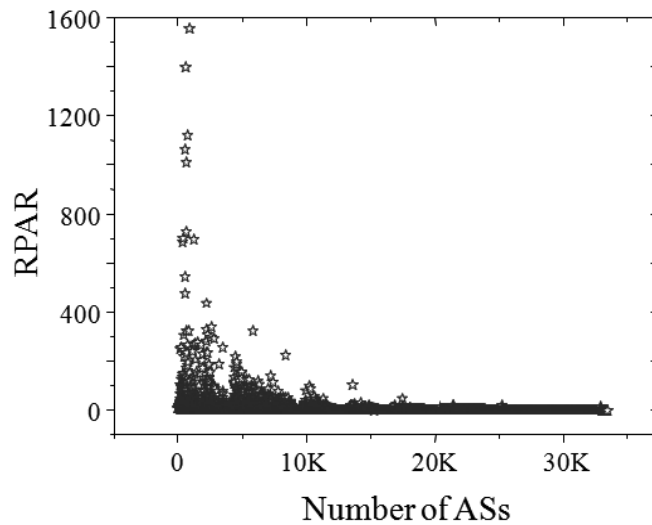

Figure 4.14. RPAR distribution in the whole AS space (ASs are sorted in decreasing order by APAR)

Observations and key lessons for NIAs: We may combine the APAR and RPAR to decide which ASs have better aggregation even when they have the same APAR. We may **take both metrics into consideration and effectively develop a deployment strategy**. Specifically, for an NIA deployment, a recursive method can be **taken** from bottom to top level or reversely to inspect the metric values for the ASs to decide suitable deployment strategies. Also, the above method will help identify where the imbalance is located in the customer cone and keep the routing plane stable.

We summarize the key metrics and their major functions in Table 4.5. For the rest of the chapter, we use the above new metrics to carry out further in-depth evaluation.

Table 4.5. Summary of the key metrics and the major usage comparison

Metrics	Metrics on individual AS's fact and behavior			Metrics reveal interactions among ASs	
	PC	AR	CAR	APAR	RPAR
Definition	Number of prefixes announced	Prefixes announced outside after aggregation inside divided by the total prefixes announced outside	Total aggregated prefixes divided by the total prefixes in the routing table for a set of ordered ASs.	Total prefixes announced by a cone of ASs	APAR divided by the number of ASs in the customer cone
Function	Depicts overall contribution of an AS to the scalability issue	Depicts how well an AS's aggregation is	Depicts how well a collection of ordered ASs' aggregation is	Depicts the position of the AS and its aggregation status	Depicts the average aggregation in the cone
Indication/ relation to other metrics	Improving aggregation of the ASs with higher PCs can improve scalability	Current aggregation is far away from ideal case of perfect aggregation with AR=1	Reveals information about a group of ordered ASs but is not able to reflect the correlation among ASs	More accurate than AR in indicating the position of AS in the Internet hierarchy	Combining APAR and RPAR can reveal more info. and help deployment

4.5.6 Deployment Benefits of Various Strategies

We focus on evaluating the effects of the strategies in reducing the routing table size, improving the PCs of each type of ASs, and improving CARs.

(1) Benefit of Total Prefix Numbers Decrease

First, we present an enhanced evaluation on the possible benefits of decreasing the routing table size. In this chapter, we address three key limitations of our previous work [8]: (1) It assumed static starting point and neglected the 20% natural increase each year, (2) it considered only the scalability driven model and only the first half phase, and no evaluation on complete scenarios of all the strategies, and (3) the predefined deployment rates (10%, 20%, and 30% each year) were too conservative for deployment. Therefore, we address the problems and conduct a more complete evaluation.

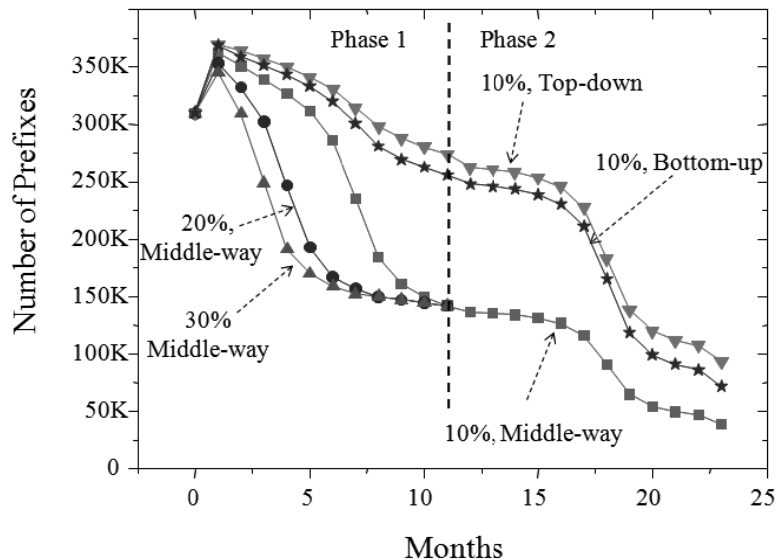

Figure 4.15. Prefix decrease for the three strategies with deployment speeds of 10%, 20%, and 30% per month.

We assume a “phase-by-phase” deployment pattern in which a specific group of ASs (such as big ISP ASs) finishes deployment following the others (such as medium, small ISP ASs or stub ASs). Hence the deployment process is divided into two phases for all the three strategies. For the sample under study, the total routing table size starts around 310K. Due to the deployment, the regular 20% natural increase every year will gradually decrease and so we simulated this effect in Figure 4.15. Initially the total routing table size increases but soon begins gradual decreases due to the continuous deployment until it reaches a level close to the lower bound of the phase. In each phase,

we curve the shapes to simulate the effects that the new technique deployment is relatively slow at the beginning and end periods and faster in the middle period.

Observations and key lessons for NIAs: Figure 4.15 shows that in terms of reducing table size, the “middle-way strategy” is more effective compared with the other two strategies in the studied period, while “top-down strategy” and “bottom-up strategy” are relatively close. For even longer term NIA considerations, we need to guarantee that whichever strategy is taken, finally it will reach the same status as expected in the NIA design. The findings in this chapter can help achieve cost-effectiveness for the deployment process.

The above observations validate our evaluation in Subsection 3.5.2 and the strategies discussion in Section 3.4 in that the middle-way strategy is mostly driven by the large number of medium- and small ISPs which are the major motivators for scalability-oriented solutions and strategies. Specifically for middle-way strategy, we consider 3 deployment speeds: 10%, 20% and 30% each month; they finally meet at the end-point of phase 1 and by then we can achieve about 44% reduction in a period of 11 months compared with about 20% reduction for the top-down and bottom-up strategies. For phase 2, the middle-way strategy finishes deployment on the big ISP and stub ASs with further 70% reduction (using the end of phase 1 as a starting point), and top-down and bottom-up strategies finish the deployment on the small and medium ISPs with further 67% reduction in the following period of 11 months. Note that at the end of phase 2 the curves of the three strategies do not meet because phase 3 deployment is still pending. They will finally join when all phases are finished.

(2) Prefix Contribution (PC) Improvement of Each Strategy

We further evaluate the PC improvements of the three strategies. First, we have the original cumulative PC data as in Figure 4.8, and we study the three strategies separately and reveal the potential difference. The results are shown in Figure 4.16. We evaluate and compare the data at the end of phase 1 deployment of the three strategies. We do not consider the deployment speeds here to avoid too much information mixed altogether. Note that we sorted the data in a decreasing order to calculate cumulative PC. In Figure 4.16, similar to Figure 4.8, the original cumulative PC distribution shows very imbalanced status. From Figure 4.16, we can see that the middle-way strategy achieves significant improvement compared with others. The shape of the curve shows that

the values of PCs are smaller than the original ones. Top-down and bottom-up strategies show close effects but not as good as the middle-way strategy.

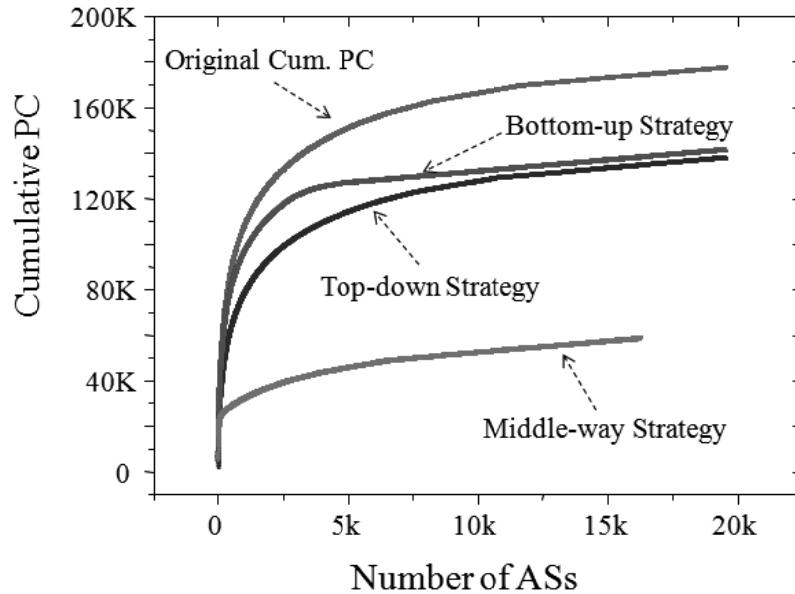

Figure 4.16 Cumulative PC improvements with the three deployment strategies

Observations and key lessons for NIAs: Intuitively, the lower the curve, the better balance is achieved in the overall aggregation of the routing system hence better scalability during the deployment progress. The difference will diminish in the NIA when the whole deployment is finished.

(3) Cumulative Aggregation Ratio (CAR) Improvements

Here we evaluate the CAR improvements by the three strategies. We continue our preliminary evaluation in [8] by: (1) basing our evaluation on new quantitative metric of CAR, (2) adding the new middle-way strategy evaluation, and (3) adding more results and discussions on the implications.

We show the CAR improvement results in Figure 4.17. Before the deployment, the CAR ranges from 0.44 for the top 50 ASs to 0.61 for the whole AS space. We sort the ASs according to their PCs in a decreasing order. For top-down strategy, we deploy first at the top ISPs and for the first step we assume half of their unaggregated prefixes to be aggregated. We make this assumption since we cannot expect that all the ISPs can finish the deployment overnight, but we can first aggregate the prefixes that failed to aggregate previously hence increase the ARs. Note that the results in this section are based on the new strategies classification, and we also added the curve for “middle-way”

strategy. It shows that the CARs are improved significantly under the top-down strategy. Note that there are several “turning points” on the curve which are marked with dashed circles in Figure 4.17. They happen to be at the intersections between different types of ASs, which matches the grouping results we found in Figure 4.12. For example, for the second point, the CAR curve turns down a little bit since most of the stub ASs cannot benefit from the top-down strategy.

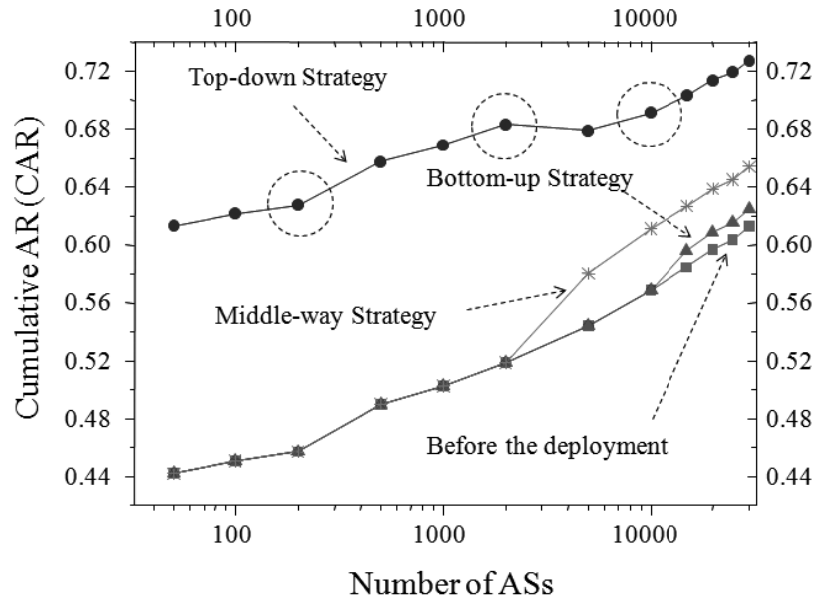

Figure 4.17. Cumulative AR improvements of the 3 strategies (Note: 1. ASs are sorted in decreasing order by their PCs; 2. Assume a first-step of 50% reduction of the unaggregated prefixes)

Similarly, we have curves for bottom-up and middle-way strategy. The middle-way strategy shows CARs improvement lower than the top-down strategy but higher than bottom-up strategy. The bottom-up strategy provides little CARs improvement indicating that it may not be as effective as the other two in terms of reducing the routing table size.

Intuitively the results in Figure 4.17 show that the top-down improves the CARs most. However, it may be a little misleading since it does not directly match Figure 4.15 and Figure 4.16 in which the middle-way literally shows the best effects in achieving PCs and total table size reduction. Note that in Figure 4.17, y axis is ***cumulative distribution*** (CDF) of the ARs and the x axis is the ASs in logarithmic decreasing order sorted by their PCs. Unlike the evaluations in Figure 4.15 and Figure 4.16, here we only focus on CAR. The left parts of the curves for the three strategies are mostly the tier-1 and big ISPs’ ASs that have higher PCs. So, deploying new solution in these ASs leads to a

significant CAR improvement for these ASs since the other ASs are not counted into the CDF yet. Combining this with the above “turning points” observation, we have:

Observations and key lessons for NIAs: For aggregation improvement, the most effective way is to follow the top-down strategy and deploy in big or tier-1 ASs first, and then combine it with other strategies by recursively improving the aggregation level-by-level starting from the bottom stub ASs. However, due to the overloaded semantic of current AS [8], changing the top of the AS hierarchy may need synergy from the customer cone. It is also the reason we define APAR and RPAR to reflect such interactions. For NIAs, such interactive mechanisms should be provided from architecture level like the inter-realm communication mechanism in [8].

4.5.7 Monitoring Deployment by Metrics' Boundary Values

We now estimate the metrics' “upper- or lower- bound” values in a well aggregated Internet. Doing this can be helpful in monitoring *the deployment progress and help put the investment into the most cost-effective parts first*. Here, the ideal case means that IP semantic overloading problem has been solved and locator aggregation is performed effectively.

(1) Prefix Contribution (PC). The PC of each AS is determined by its position in the AS hierarchy. For tier-1 ASs, their PCs are at least 1 (sufficient), or more than 1 (more than minimum, but may be allowed for transition or temporary engineering purposes). Other ASs' prefixes are not needed to appear in the routing table since they will be aggregated by the tier-1 ASs' prefixes. Hence,

$$PC = 1 \text{ for tier-1 ASs, and } 0 \text{ for all the other ASs} \quad (1)$$

Certainly, during the interim period before reaching the ideal case, the PC of the ASs will be larger than the values in (1) and it will get closer as the deployment proceeds.

(2) Aggregation Ratio (AR). In the boundary case, each AS will aggregate the prefixes under its domain and announce outside only one aggregated prefix covering all its space. That is to say,

$$AR = 1 \text{ for all ASs} \quad (2)$$

Note that AR=1 does not guarantee perfect aggregation, but perfect aggregation always means AR=1. For aggregation improvement progress, AR is a good deployment touchstone.

(3) **Cumulative Aggregation Ratio (CAR).** Similar to AR, as long as the ASs perform efficient aggregation, for ASs in each level, no matter where they are located in the AS hierarchy, the CAR will be one. That is to say,

$$\text{CAR} = 1 \text{ for all ASs} \quad (3)$$

(4) **Absolute Prefix-to-AS Ratio (APAR).** From equation (1), for tier-1 ASs that have prefixes announced in the routing table, due to the perfect aggregation, their APARs will be equal to the PCs since their downstream ASs' prefixes are aggregated by its single prefix. That is to say,

$$\text{APAR} = 1 \text{ for tier-1 ASs, and } 0 \text{ for all the other ASs} \quad (4)$$

Though APAR and PC demonstrate similar boundary values, they have different meanings in evaluating the progress of **deployment**. Specifically, PC describes a single AS's behavior while APAR shows a set of ASs' behavior in the customer cone. They cannot replace each other. Instead, combining these two is an efficient way to monitor the progress of the aggregation inside an AS customer cone.

(5) **Relative Prefix-to-AS Ratio (RPAR).** RPAR value is the APAR divided by the number of ASs in the cone. Hence,

$$\text{RPAR} = 1/\Sigma (\text{AS})_{\text{cone}} \text{ for tier-1 ASs, and } 0 \text{ for all the other ASs} \quad (5)$$

It is easy to see that the boundary RPARs for the tier-1 ASs are very close to 0 while the others are all 0. RPAR shares little difference between top-tier and the lower-tier ASs. But in the deployment process, the dynamics of such differences can be used as an effective way to monitor the progress.

For the total routing table size, in ideal aggregation case, it can be the number of tier-1 ASs. However, it is also possible that each tier-1 AS may announce a little more than 1 prefix. This is controllable due to the small amount of tier-1 ASs. It will also be smaller than the total number of ASs since most lower-tier ASs' prefixes are aggregated and will not appear in the inter-domain routing table. Hence, the changing dynamics of the table size can be a vivid “index point” for the deployment progress of the new architecture.

4.6 Reasoning to New Internet Architectures

In this section, we present the discussion on the reasoning of the evaluation results to NIAs.

4.6.1 Evaluation Results

(1) Quantitative metrics and the corresponding evaluations reveal new findings useful for NIAs. This section shows many facts and trends on the status of the current inter-domain routing system, the contributions of different types of ASs (big, medium, small ISPs' ASs, and customer ASs), their relationships and interactions (AR, CAR, APAR, RPAR, etc.) leading to the problem space, and the underlying implications. It provides useful tips for how the problems can be effectively alleviated or solved. It also lays the foundation for further incentives and deployment strategies evaluation.

(2) Successful design and deployment of new architectures need full consideration on incentives for both customer and ISPs, and with balanced strategies. Any change to the Internet needs appropriate incentives to get a chance to succeed. This observation is validated by the NSF report [110] on latest trends in the future Internet research. In the evaluation, we find that various deployment orders lead to significantly different results. Thus, we are interested in how new solutions can benefit from the findings for different interest groups. We discuss real incentives, specify their major motivators, and show how they can influence the formulation of practical deployment strategies. Further evaluation of the major benefits of the three strategies shows effectiveness and underlying implications concerning all possible improvements.

(3) Boundary value analysis for various metrics provides good guidelines for monitoring and evaluating the deployment progress of new architectures. New architecture designs, even with solid technical qualities, may have to experience long deployment and evolution process. For various strategies, this process can be monitored and measured by boundary values of various metrics and can serve as an “index value” for improvements. Hence achieve cost-effectiveness by dynamic adjustments of these strategies.

4.6.2 The Balance Issue

It is impossible to get absolute balance for the routing system since ISP ASs have different roles than stub customer ASs in the AS hierarchy. Instead, by better balanced Internet we mean that ASs with similar roles ("type 2 imbalance" as discussed in Subsection 4.5.3) should be equal in sharing the responsibilities of keeping the prefixes aggregated in a sustainable and balanced way. We can discuss the imbalance in technical and non-technical senses. Technically, the current routing design

is old and its enforcement does not address the prefixes allocation and aggregation very well. Hence, future Internet has to address the weakness and pitfalls of the current design. With new principles, NIAs have to be open and consider all the current limitations and define clear and feasible changing steps. From non-technical aspects, the Internet is currently intertwined with commercial interests of ISPs and customers. *The imbalance of the routing system is an embodiment of the imbalance underlying the social commercial interests.* Hence in the future design, the commercial and human factors need to be included into the architecture design, i.e., the future Internet is a "*network of the people*". Hence, balancing incentives for all stakeholders at every step of the changes is important.

4.6.3 Short- and Long-term Goals of Future Internet

(1) **On short-term goals and effects.** The evaluation provides hints on how to achieve short-term routing scalability with various speeds. For example, several quantitative metrics' values can be improved directly or indirectly. For direct improvement of an individual AS, we may first improve the PC and AR, since improving the inner aggregation of each AS is relatively easier than improving a whole AS customer cone. By carrying out such improvements step-by-step in different ISPs' ASs, the overall routing scalability can be improved significantly. For indirect improvement, the two metrics of APAR and RPAR demonstrate the behavior of a group of ASs and their integrated impacts on the rest of Internet. Combining these two metrics can further improve the overall routing scalability. The boundary values of these metrics can be used to evaluate how well the short-term goals have been achieved.

Moreover, various deployment strategies lead to different effects in achieving the short-term goals depending on the real demands. Multiple incentives decide the existence of various strategies and hence different short-term achievements.

(2) **On long-term goals and effects.** The new findings of the evaluation also provide important guidelines for future solutions aiming at a long-term architecture evolution. For such considerations, the new architecture has to be open and extensible to accommodate demands and changes from ISPs and users, which may urge design principles different from the original ones [111, 112]. From a practical view, Internet should be able to evolve from the current through gradual steps.

Moreover, evaluating the current Internet is too difficult and inconvenient [102]. For long-term consideration, *systematic monitoring and evaluation capabilities (methods and tools) should be provided and supported at the architecture level*, to identify problems and find needed changes. In other words, the AS-level analysis method used in this dissertation as all other existing work do not have to worry about the limited data sources and the limited inference methods. Instead, the innovative *quantitative metric method used in our work can be a norm and a part of the NIA itself*.

4.6.4 Limitations of the Evaluation

Several limitations of our evaluation are worth discussing:

- (1) Our evaluation is based on some existing public BGP data sources. However, every BGP observation point has its limited visibility. Other useful data like finer-granularity traffic patterns of the ASs are hard to get because of the non-disclosure agreements of the Internet stakeholders [113].
- (2) The existing topology data and the pre-screen algorithms we use may also not be accurate enough due to the extreme complexity of the inter-domain routing system.
- (3) Internet is changing fast and many latest trends may not be revealed in our work.
- (4) In deployment benefits evaluation, we only consider some solutions; but future ones may deviate from them.

Due to these limitations, the evaluations are not 100% accurate. However, our goal is to present reference and guide for the potential new architectures, which is the unique contributions of our work as the first such effort.

4.7 Short Summary

In this chapter, we tried to fill a gap between the designs of new Internet architecture and the evaluations efforts through an AS-level inter-domain routing system evaluation. The major idea was systematically defining a series of quantitative metrics to reveal hidden information and observations that may be useful in improving the status and deploying candidate new architectural solutions. The results of the evaluation can further be applied to find the deployment strategies with balanced incentives for both customers and ISPs.

Chapter 5

Review of the Research on Energy Efficiency in Buildings and Microgrids using Networking Technologies

In this chapter, we focus on reviewing the key research topics and issues on energy efficiency in buildings and microgrids using networking technologies. The content of this chapter is primarily based on one of our publications [14].

5.1 Introduction

Intelligent buildings and microgrids are important parts of the future smart grid. Energy efficiency in these buildings and microgrids usually refers to reducing the amount of energy required to provide specific products and services by adopting novel technologies or methods. For example, existing work includes improving the insulation of the building to reduce heating and cooling energy consumption, using fluorescent lights or natural lights to reduce energy usage while maintaining the same level of illumination, designing the buildings and subsystems according to their physical location and climate zones, and improving the energy conversion process to reduce energy waste during the process. Apparently, energy efficiency for buildings and microgrids can be a complex issue and many experts and researchers have been working on it from their own perspectives, and some related work can be found in the reference [120]. For example, a building designer may be concerned about the inner structure that could affect the energy flow; a physicist or HVAC (Heating, Ventilation and Air Conditioning) expert may be interested in the thermal effects due to the physical structure of the buildings; the electrical and computer engineering experts may focus on deploying

smart meters and computer networking systems to provide automation and collect data for further analysis and building retrofit.

In this chapter, with a networking perspective, we define the energy efficiency for buildings and microgrids [127, 131-147] as efforts not only using a specific technology or method, but a series of methods treating the individual building or microgrid as an integrated system, and applying related networking and control technologies to enable it to reduce unnecessary energy usage and to achieve a large-scale energy proportionality. Specifically, we focus on the energy efficiency issue not only in intelligent buildings but also microgrids formed by multiple locally-distributed such buildings.

An intelligent building is generally defined as a building integrated with a building automation system (BAS) [148] which provides functionalities such as computerized, intelligent, and networked distributed control to monitor and control the HVAC, lighting, safety and security, and other appliances while reducing energy consumption and maintenance costs. It also provides its occupants with a flexible, comfortable, secure, and productive environment. The intelligent building concept has a relatively long history since the development and expansion of computer and networking and communication technologies in 1980's [13, 149]. Initially, it attracted a lot of attention from both academia and industry, and a number of researchers expressed their exciting vision about future intelligent buildings. However, the reality fell short and it turned out to be a relatively long and slow process, especially in the area of smart building controls and automation. There are many reasons behind this. First, the key in-building intelligent systems like energy management and control systems (EMCS) for building automation have been underutilized except for some large-sized buildings. Even in the buildings with such systems, only a fraction of the possible EMCS functionality is utilized. Second, it is about the cost. Generally, the initial cost of an intelligent building is higher than a conventional building and the benefits are mostly not visible at the stage of construction. Third, individual subsystems inside intelligent buildings are usually provided and maintained by different software or hardware vendors and they are often developed as proprietary products. The lack of standardization of the protocols prevents the necessary interoperability and interactions among the subsystems which are important to create a truly coherent intelligent building. Fourth, many subsystems such as building monitoring and control, elevator monitoring, and security systems are under separate construction contracts and they usually install and use their own communication systems. Better interconnection and integration of these systems without duplication is necessary to realize a fully intelligent building.

Because of all these reasons the deployment rate of intelligent buildings has been slower than initially envisioned. However, two recent developments and trends have reactivated this important and promising topic, and accelerated the research and application of related technologies. These are as follows:

(1) Skyrocketing Energy Prices and the Need for Sustainability: The energy crisis has made us rethink our previous energy usage of the last several decades. The global warming alarm and huge CO₂ emission have also alerted us to look for a new sustainable energy pathway to the future. **Renewable energy** sources such as solar, wind, and geothermal energy are more and more promising in many situations in terms of global sustainability. Buildings, as a significant source of the total human energy consumption, become a meaningful research and application arena not only for saving energy and reducing operation cost but also for making everyone's life better since we all live and work in various buildings most of our lifetime.

(2) Rapid Popularity and Maturation of Smart Phones Technology and Internet Technologies like Cloud Computing: In recent years, the world is experiencing a dramatic change from the PC (Personal Computer) to mobile smart phone devices. The broad prevalence of various smart phones and PADs (personal access devices) are changing the users' habit and also creating more possibilities for the future. For example, using appropriate mobile applications on such devices, it is possible to make users aware of the running status of the building energy systems. Also it enables every smart phone holders to participate in the control and operation of intelligent buildings in a real-time distributed manner from anywhere due to the ubiquitous, seamless, and multi-interface mobile Internet connection. Moreover, Internet technologies like cloud computing [150] are making it possible for more advanced interactions between energy consuming buildings (buildings can also be a source of energy using renewable energy generators) and the smart grid or microgrids. By interconnecting multiple intelligent buildings in a local microgrid and by interacting with the external grids, energy efficiency optimization and automation can be achieved beyond a single building.

In this new context, we investigate the key research topics through a broad survey of the latest development status of intelligent buildings and microgrids formed by multiple such buildings. We aim to draw an overall picture of the current research and potential future applications, especially in terms of energy efficiency and the mobile/cloud computing enabled Internet. In our opinion,

combining these recent developments of the Internet and applying these to the area of intelligent buildings and microgrids has the potential to accelerate the deployment of intelligent buildings and to have a profound impact on global sustainability.

5.2 Intelligent Buildings: Overall Framework

In this section, we investigate the overall framework for intelligent buildings and related subsystems.

5.2.1 Overall Framework

To create an intelligent building, multiple stakeholders need to be involved. They include the building constructors, electrical system providers, HVAC providers, security system providers, control and management system software and hardware providers, and others for appliances like lighting and elevator systems, etc. If renewable energy generators are installed in the building, then the generators providers are also involved. The subsystems are usually from different providers with separate contracts. However, to create a truly intelligent building, integration among different systems is necessary to save cost and to create interactions and coordination among them to maximize efficiency.

Basically, we summarize the three key modules surrounding the intelligent building concept:

(1) Building Automation System (BAS): It is responsible for the monitoring and control of multiple building subsystems such as building security and access, fire and life safety, etc.

(2) Building Energy Management and Grid Interaction System: It is in charge of the energy-related operation and energy efficiency function such as energy generation, storage, metering, and systems monitoring. It is also in charge of the functional relationship to the outside smart power grid.

(3) Building Management Information Technology (IT) System: It is a high-level management system built with multiple applications based on voice, video or other data services. These applications interact with the above two modules for better intelligent building functionalities and performance.

Note that each of the three key components has different focuses in the overall framework. Specifically, in the outer level of the Figure 5.1, we can see that the BAS primarily focuses on the

monitoring and control of multiple building subsystems such as fire and life-safety systems, building security and access systems, etc. It aims to optimize the performance of systems and reduce interference among different mechanical subsystems inside the building. The energy management and grid interaction module actually is in charge of the energy-related operation and energy efficiency function. For example, the lighting, HVAC, and various utilities are monitored by a smart metering infrastructure, and also renewable energy generators and energy storage systems which are connected to the grid. Consider a subsystem like HVAC, its operation may be monitored and controlled by the BAS but the energy-related function is fulfilled by the energy management and grid interaction module, hence one subsystem in the building may interact with other modules in the framework for different functionalities. In the top part of the Figure 5.1, the building management IT system provides many applications using voice, video, and data services. These applications interact with BAS for better subsystems monitoring and control, and interact with energy management and grid interaction system for better decision and cost optimization.

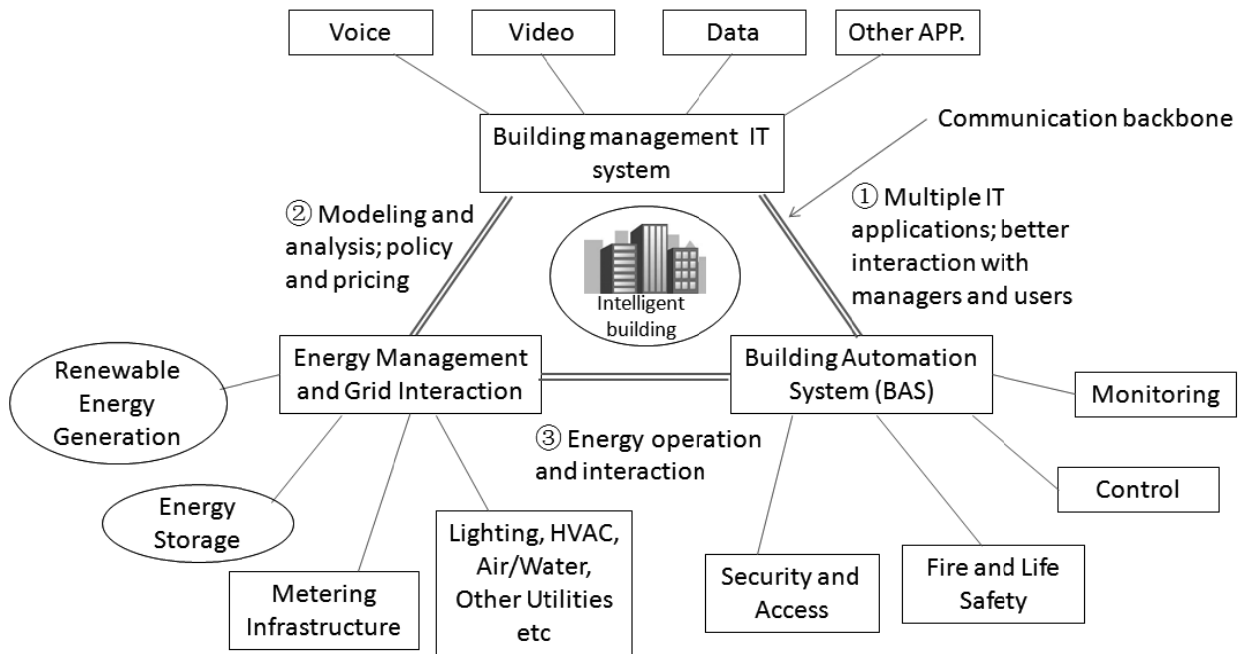

Figure 5.1. Intelligent buildings and related subsystems

These three components need to be integrated and need to cooperate well to fully harvest the benefits of an intelligent building, and further nurture interaction among multiple such buildings to form microgrids. To enable a true intelligent building, the three key modules are also needed to connect to each other through in-building integrated communication network backbone (usually

using open communication protocols such as Internet Protocol, or IP [151]). The overall framework of these components and their interactions is illustrated in Figure 5.1.

As shown in the figure, these components interact with each other to achieve various goals. Specifically, the BAS subsystem [148], denoted as ① in Figure 5.1, needs to connect and interact with the building management IT system to enable multiple voice, video, or data applications over the underlying BAS components. Multiple applications may better engage the building managers and users to be aware of the building current running status, and to control or tune the performance of the BAS. The building management IT system, shown as ②, also interact with the building energy management and grid interaction system to monitor and gather energy consumption data through smart metering system and store them for further modeling and analysis. The results can also be used to interact with the grid for energy pricing, or in-building energy usage policy related decision making processes through a series of algorithms and computation. Also, the energy infrastructure inside the building, such as renewable energy generation and local energy storage, need to interact with the outside smart grid to fulfill dynamic pricing and smart scheduling functionalities through the communication and networking technologies. BAS not only controls the automation of the building, it is also partly responsible for the operation of the energy systems in the building, i.e., the grid inside the building as indicated by ③. The policy and strategies formed by the IT management system are executed by the BAS system by working together with the energy infrastructure.

5.3 Intelligent Buildings: Key Subsystems

In this section, we investigate and discuss several subsystems and key components in intelligent buildings.

5.3.1 Integrated Communication Network and Building Management IT System

The communication network inside the building and the building management IT systems are two key components.

(1) Integrated Communication Network. Currently, building subsystems are usually covered by separate contracts and various vendors deploy their own communication networks separately.

Devices of various vendors use different protocols and use translators to communicate with each other. This causes a lot of waste and makes it difficult to integrate. In other words, for a full intelligent building, integration of different subsystems through a consolidated common communication infrastructure is necessary. It can improve synergy and interaction among subsystems. This idea is shown in Figure 5.2.

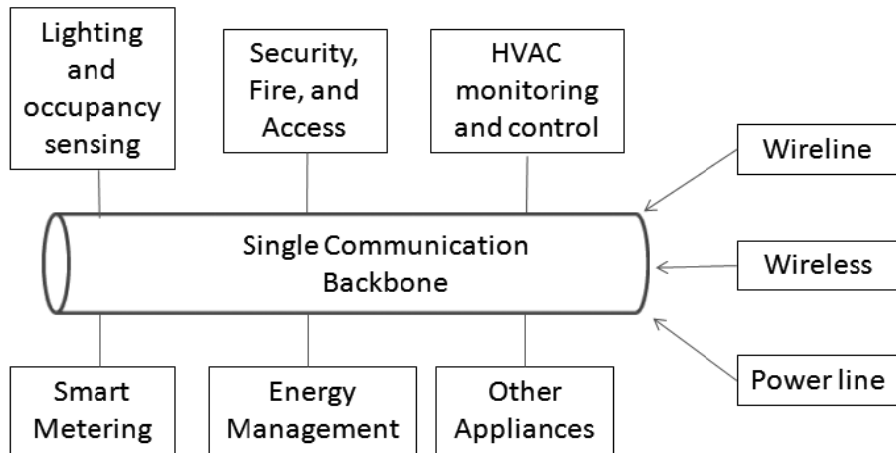

Figure 5.2. Integrated communication system of intelligent buildings

From communication technology perspective, currently there are multiple **wireless and wired technologies and protocols**. Depending on functions of the subsystems, suitable communication technologies may be used. For example, for security and fire safety systems, elevator and escalators, and health monitoring systems which are required to be very dependable, a highly reliable wired network backbone across the building is needed with backup power supply to ensure working even in unusual and hazardous situations. In comparison, less critical subsystems such as the networked lighting sensing system can use wireless networking technologies [152] with low-cost, easy deployment, and low-reliability but of great resilience to wired network failures and good energy efficiency. Similarly, in some applications where network cables are hard to deploy, **power-line communications (PLC) technologies** [153] may be used.

We use the Table 5.1 summarizing the major communication media that could be used in the building environment, comparing their advantages and disadvantages, their major usage, technology names, and industry standards. It also demonstrates the main problems of various communication media and technologies in the building environment.

(2) Building Management IT System. The building management IT system shown in Figure 5.1 could potentially include a series of value-added business-related voice, video, and data applications. Examples of such applications include those related to energy market modeling and monitoring, real-time energy pricing by interacting with the smart grid, energy demand/response, and billing systems. These systems guarantee how an intelligent building can be operated and managed profitably as well as efficiently. Note that some tasks of the building management IT system related to energy overlap with the energy management and grid interaction system shown in Figure 5.1. The difference is that the building management IT system is more about high-level business applications, while the energy management and grid interaction system is more about the interior operation and interaction with the outside smart grids.

Table 5.1. Communication media, technologies, standards, and comparisons

Media	Advantages	Disadvantages	Major usage in building	Technologies	Standards
Wireline	<ol style="list-style-type: none"> 1. Reliable and stable 2. Secure 3. Technologies mature 	<ol style="list-style-type: none"> 1. Expensive 2. Hard for wiring 3. Inflexible 	<ol style="list-style-type: none"> 1. Network backbone 2. Connect systems need high security and reliability 	Ethernet (LAN)	IEEE 802.3 series, 802.1 series
				HomePNA	HomePNA 2.0: ITU-T G.9951-3; HomePNA 3.x: ITU-T G.9954
				G.hn/HomeGrid	ITU-T G.9960, 9961, 9963, 9970,
Wireless	<ol style="list-style-type: none"> 1. Reduced wiring and cost 2. Wide coverage 3. Support broadcasts 4. Flexible deployment and high reconfigurability 	<ol style="list-style-type: none"> 1. Possible security leak 2. Instable and lossy link 3. Limited signal propagation range in built environment 	<ol style="list-style-type: none"> 1. Complementary to the wireline 2. Resilient and reconfigurable monitoring 3. Data and voice communications 	WiFi	IEEE 802.11 series including (a, b, g, n)
				Bluetooth	IEEE 802.15.1
				ZigBee, 6LoWPAN, Wireless HART, etc.	IEEE 802.15.4 series
				Ultra-Wideband (UWB)	IEEE 802.15.3 series
				RFID (Radio Frequency Identification)	ISO 14223, 18185; ISO/IEC 14443, 15693, 18000, 18092, 18185, etc.
Optical	<ol style="list-style-type: none"> 1. Reliable and stable 2. High speed and bandwidth 	<ol style="list-style-type: none"> 1. Expensive 2. Difficult to wire 3. Inflexible 	<ol style="list-style-type: none"> 1. Access network 2. High speed data transfer 	IrDA	Specifications across the OSI stack (include IrPHY, IrLAP, IrLMP, Tiny TP, IrCOMM, IrLAN, IrSimple, etc.)
Powerline	<ol style="list-style-type: none"> 1. Low cost 2. No special wiring 3. Flexible modification 4. Easy installation 	<ol style="list-style-type: none"> 1. Not suitable for large-scale deployment limited by some transformer 2. Instable signal and link 	<ol style="list-style-type: none"> 1. Smart home appliances 2. Home automation 3. Internet access 	HomePlug	IEEE 1901
				UPA: Universal Powerline Association	UPA Digital Home Specification v1.0, and other 2 related specifications
				G.hn/HomeGrid	ITU-T G.9960, 9972

5.3.2 Energy Management and Grid Interaction

This subsystem consists of energy management and building-grid interaction. The major functions of the energy management generally include: (1) in-building metering infrastructure, and data collection and analysis; (2) management subsystem for HVAC, lighting, and other utilities; (3) renewable energy generation and energy storage. A typical example method of the building-grid interaction is "demand response".

This management subsystem analyzes the resource usage data obtained through the in-building metering subsystem and passes the results to the business applications of the building management IT system. It actually serves as a mediator between the metering infrastructure and the building automation system in the sense that the metered data are passed and processed by it and the results are fed back to the high-level applications to initiate the building automation process as a response. The energy management subsystem also performs the management functions for individual utility systems in the building. Finally, the energy management and grid interaction subsystem also manages the in-building renewable energy generation and energy storage subsystems, and enables better integration of renewable energy resources to the traditional power grid in buildings.

(1) Smart Metering Platform. Smart metering [23] infrastructure monitors the consumption of multiple resources such as electricity, water, gas, heat, etc. It also enables us to know not only how much energy is consumed but also how and when they are consumed. It is the foundation of the smart grids and also the fundamental component of intelligent buildings. It usually comprises of multiple networked sensors of different granularities that monitor various building loads and send information back to control systems through a network backbone. The metering infrastructure is separate and different from the building automation system (BAS) in that it has built-in storage facilities and needs to be more open and available to the stakeholders such as building owners, tenants, and managers.

It is also different from the conventional metering facilities in the sense that it allows a two-way communication capability. The reading instructions and data can be sent remotely to the central servers. There is also a trend for it to use TCP/IP protocol suite as a common platform. Some also suggest the separation of the grid meter function from the communication modules to enable a universal metering interface without using specialized communication standards and lowering the investment risks.

Smart metering can be used to work closely with demand response (DR) by interacting with the smart grids. Such interaction provides real-time pricing information and helps the building managers run specific policies to reduce energy usage during the peak periods and thus reduce costs and lead to a better energy usage. It also allows the utility companies to manage the demand and supply in a balanced and effective way which is good for running and operation of the whole grid.

(2) Renewable Energy Generation and Energy Storage. Conventional power generation involves usage of scarce fossil fuel and coal which are expensive and have impact on the global climate. Long distance transmission of electrical power also introduces high power loss and high initial infrastructure construction costs. Thus, the integration of green and renewable energy resources (solar, wind, geothermal, etc.) has become a promising trend for global climate control and sustainability. "Local generation, local consumption" notion can significantly reduce the waste and enable energy efficiency and sustainability.

However, renewable energy sources, such as solar and wind, have intermittent and variable availability and may not be able to provide energy when users need them most but provide it when the users may not need it. To solve such mismatch, it is necessary to use energy storage systems to temporarily store the energy for future demand and to share the excess energy with neighboring buildings that may be able to use it, i.e., by forming a microgrid.

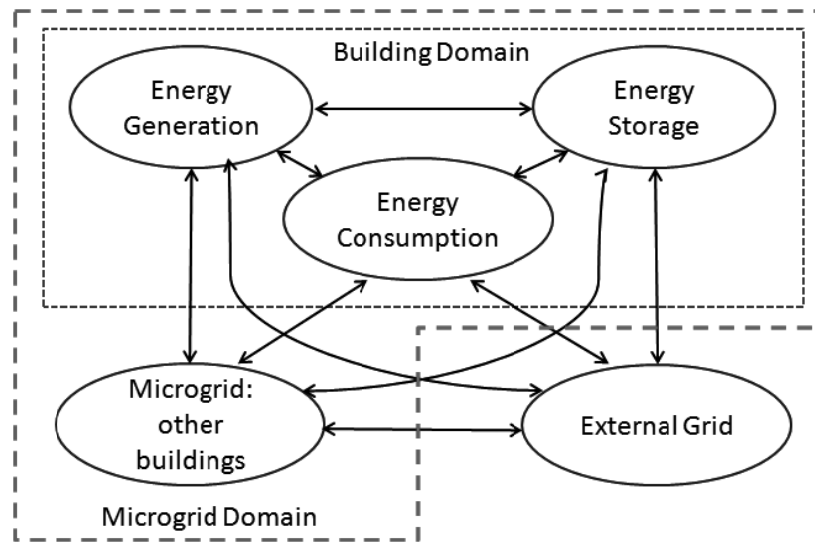

Figure 5.3. The relationship among energy generation, storage, consumption, and external grid in intelligent building and microgrid level.

At the microgrid level, the renewable energy generation and energy storage subsystems in intelligent buildings can further interact with the external grid and form a certain level of interaction and synergy to achieve a specific set of goals such as minimum energy import from the external grid, lowest overall energy cost, and lowest peak-time energy consumption, etc. The relationship among these subsystems and their interactions are shown in Figure 5.3. We can see that the three components in individual building domain interact with each other as well as with other buildings in

the microgrid. The buildings and/or microgrids can import/export their energy from/to the external grid depending on the real demands and strategies.

(3) Demand Response and Demand Side Management. The energy management and grid interaction subsystem is also responsible for the automated demand response (DR) [154] function and demand side management [155, 156]. DR is one of the types of building-grid interaction. It is now very broadly used in not only large office buildings but also residential buildings and smart homes.

It is linked to the smart grid for demand-provider mutual negotiation and dynamic utility pricing. It means that the building-side energy consumers actively monitor the grid-side power supply conditions and prices, and shut off some loads to reduce part of the energy consumption to avoid expensive energy usage during the peak times, or, start their own energy generators to meet the actual demands. This method is a little different from those trying to improve the energy efficiency in the building which basically tries to reduce the energy consumption without changing the tasks. DR means that the demands are restricted as a reaction to the energy prices in the utility market. DR provides multiple financial and operational benefits for users, grid operators, and utilities services. Typical benefits include reduced energy usage for end-users, lower wholesale energy market prices, and grid operational security benefits. Most of such functionalities and features are missing in conventional buildings. In more advanced cases, automated demand response can be developed over multiple suppliers to enable an automated strategy for different devices related to lighting or HVAC.

(4) Future Building-Grid Interaction for Energy Efficiency. Building-side grids (microgrids) are important parts of the smart grids. It is an important and challenging task to make them smarter and enable them to collaborate with the external grids to achieve better efficiency and cost-effectiveness. Especially, in the future, renewable energy generators may become available in local interconnected buildings, and they are also connected to the smart grids. If the generators' capability exceeds the microgrid's own demands, it will export the remaining energy to the external smart grid. Dynamic and optimized scheduling of these distributed generators located in multiple buildings can feed the demands better and reduce the overall cost. It can also achieve better energy efficiency in not only building scale but also in community, city, state, and even country scales. Also, through dynamic interaction between the intelligent buildings and the smart grid, not only the building-side users can

reduce their energy consumption and use energy more efficiently by avoiding high peak-time energy usage, the utility-side energy providers can reduce the peak-time load, allocate the power generation capacity more efficiently, and avoid constructing expensive new power plants for peak time demands.

5.3.3 Building Automation System (BAS)

BAS is a computerized distributed control system which automates the monitoring and control of various mechanical and electronic systems in intelligent buildings.

(1) Major Functions. BAS provides the most basic control functions for the major subsystems such as lighting, HVAC, water, gas, occupancy sensing, building access, and fire and safety systems. Using principles of control theory, BAS controls the operation of multiple feedback loops to keep a series of parameters under the set ranges without manual intervention. BAS system is one of the key differences between intelligent buildings and conventional dumb buildings. According to recent research [157], the market for BAS is expanding fast and there is potentially a great opportunity for research, standardization, and application in the near future.

BAS generally consists of multiple hardware and software entities including various sensors, actuators, controllers, and corresponding software. Multiple algorithms are embedded into the scheduling, controlling, and decision-making processes of the systems. BAS builds on top of the integrated communication backbone on which multiple types of data packets for different subsystems can be sent. The protocols for BAS are supposed to support the intercommunication among different subsystems. It integrates multiple subsystems and optimizes the performance by increasing interactions among them. The integration of multiple subsystems through open standards and protocols is critical for an effective and efficient BAS. The integration of BAS with other components in Figure 5.1 also affects the overall effectiveness of the intelligent buildings. As a summary, the BAS has the following key functions: (1) improved automated operation and monitoring of the subsystems; (2) optimized start (restart) and stop of subsystems like HVAC; (3) automated system diagnosis, abnormal event alarming and logging; (4) modeling and predicting potential problems and preventing them through extra intervention; (5) optimized maintenance scheduling and decision making.

(2) Standards and Protocols. The protocols, as the outcome of standardization process, are always bound to huge commercial market interests. The standardization makes the process very competitive among multiple stakeholders. The development of the Internet and computing benefited a lot from the openness of the standardization process. Such lessons also apply to the intelligent building industry. Just as the integration of multiple systems is a key for an intelligent building, *open and widely-accepted standards and protocols are the keys for the effective integration*. The standardization will help create interoperability and synergy among various participants of the markets. Compared with the private protocols, open standards allow all interested parties to join in and contribute. The process also potentially reduces the risk since the protocols usually have to be reviewed and evaluated by all parties, and any potential bug and issue can be found out and addressed. Specifically, it helps create a virtuous cycle among the three factors of *innovation, standardization, and investment*. Such cycle is valuable in promoting new advanced technologies into real applications and nurturing market's acceptance of new technologies related to the intelligent buildings. Two popular and leading standards for BAS in the intelligent buildings are: **BACnet** which stands for Building Automation and Control Networks (BACnet) [158] and **LonWorks** [159] which stands for "Local Operation Network". More details of them and other BAS protocols can be found in our paper [14].

(3) Lessons Learned for the Protocols and Standards. Given the long list of the various building automation tools and relatively long history of the development of these tools, we discuss briefly the lessons [114] we learned from the protocol development and standardization process.

- **Compatibility and Interoperability Issues.** Two major BAS protocols of BACnet and LonWorks are not compatible with each other. For the devices supporting one of these two protocols to talk to each other, a proxy device is needed. In the future, for a specific protocol to be more widely recognized and accepted, or for it to gain consensus in the research and industry community, multiple options and choices should be provided and included. **Interoperability** is needed and provided by default. In other words, it should be compatible or interoperable with other protocols. This is the case for all the current BAS protocols.

- **Security and Privacy Concerns.** As the application of smart technologies in the building environments becomes more and more popular, significant concerns on the security and privacy issues arise. This calls for appropriate security models to cover these concerns. For example, when

integrating multiple subsystems provided by various vendors into a truly smart building, it is important to design, implement, and enforce a set of unified security and privacy rules or policies to avoid potential security and privacy leaks.

- **Systematic Design and Evaluation.** Generally the current subsystems in the buildings are installed separately without systematic formal designs. But formal specification of designs and the corresponding automated tools for evaluation are necessary to ensure a valid and effective implementation and deployment of building automation system. Thus, in the long term, it is required to have such protocols and methods standardized to evaluate and guarantee the system reliability, dependability, and performance. More studies and standardization efforts in this aspect are needed in the future.

In summary, the development of the standards will speed up the maturity of the markets related to intelligent buildings and enable multiple vendors to provide interoperable devices with various features and prices. Open and competing markets will potentially nurture new intelligent building technologies. In the future, a limited number of well-accepted and open protocols may be desirable for the development of the intelligent buildings.

5.4 Small Residential Buildings: Smart Home

So far, most of our discussions are about the general issues in mostly large-sized commercial office buildings. However, for general residential buildings, or home buildings, there are a series of specific issues.

5.4.1 Large Office Buildings vs. Residential Buildings

Buildings are complex systems and various types of buildings may demonstrate significantly different energy consumption patterns. Compared to large-sized office buildings, small or medium sized residential buildings usually have smaller numbers and types of appliances, and the scales of the appliances can also be different. For example, the HVAC system in smart homes can be much simpler and much easier to control according to the occupants' dynamic schedules. Compared with the general fixed pattern and centralized control of large-size office buildings, the smart phone based location-aware automated energy control system is relatively more suitable for the small or medium

sized residential buildings. It is relatively easier and more realistic to apply finer-grained and dynamic energy control in these buildings without the involvement of multi-level policies from different levels of organizations.

5.4.2 Home Automation

Home automation is a specific case in residential buildings for the general concept of *building* automation. Due to the different scopes, home automation has a different focus. Specifically, the types of appliances in the residential buildings are relatively limited, and the total energy capacities are also not as large as those in commercial buildings. The central goal of the home automation is to meet the occupants' demands in terms of security, comfort, convenience, and energy efficiency. Generally, it consists of a light-weight HVAC, lighting system, and life safety and convenience appliances. Smart homes can also include smart health related appliances and services to improve the in-home life quality for the elderly and/or disabled populations. Typical home automation related appliances that the general intelligent office buildings do not have include the home entertainment systems such as home theatre and home gaming systems, real-time household monitoring and controlling equipments for air-conditioners, washers and driers, back-yard watering, pet feeding, floor cleaning robots, security and access control, etc. These systems can be connected through computer networks to a central system and potentially allow remote control from Internet after appropriate authentication. Overall, the home building automation system structure is simpler than the structure shown in Figure 5.1.

The home BAS is prone to be more specialized according to the occupant's own preferences or interests. Many interesting automated applications and scenarios may be deployed in the home area. For example, besides new functions, the home owners may be interested in **energy efficiency** and install smart thermostat systems to dynamically adjust and predict the running of the HVAC system according to his/her own working or resting schedules.

A typical example of home specific appliances management project is the HomeOS from Microsoft [160, 161] which aims to develop a dedicated operating system and allow a centralized control of devices for homes. Load monitoring and metering in smart building using home automation protocols is the topic of research at many universities, e.g., [162].

With technological developments, advance and maturity of standardization process, and popularity of the smart phone and Internet technologies, the cost of making home smarter is consistently decreasing. Specifically, more products are using iPhone or Android mobile applications to enable users to monitor and control in-home devices and systems in real-time. This trend makes common people be more acquainted to the smart home applications and begin accepting these low-cost systems. Moreover, the automated systems help enhance and improve the users' everyday life quality. They also help **reduce energy consumption**, save costs in the long run and promote global sustainability.

5.4.3 Home Area Network (HAN)

In home buildings, given their smaller size compared with the general commercial intelligent buildings, their consolidated communication network can be relatively simpler. A new term "Home Area Networking" (HAN) is used to describe the networking technologies that connect all the smart or computerized devices inside the homes for automation or Internet-based access and control.

There are a series of specific research projects focusing on home area networks [163-166], access control for data and devices inside home buildings [167, 168], and home network management issues [169, 170]. In this section, as one of the key perspectives discussed, we focus on the networking aspect, particularly the communication technologies and protocols that can be used in home buildings.

Multiple communication media can be used in a home building: wireless radio, UTP (Unshielded Twisted Pair) cable, telephone line, coaxial cable, and power line. Specifically, wireless networking technologies are very cost-effective for deployment in the residential buildings to interconnect various smart devices. Power line communication can also be used since normally all the power appliances in a single residential building are under one power transformer's territory. One of the typical scenarios is that the devices use TCP/IP protocol over multiple types of physical media and they connect to a central router running Network Address Translation (NAT) acting as a proxy server with firewall between the intra-home network and the Internet. The router can also be a WiFi access point for wireless devices in the building. Such scenarios enable the global accessibility and security of the home networks.

However, for home area network, some typical challenges that need to be addressed include: (1) How to make sure that the wireless signals inside the home building can cover the entire building without loss of any possible communications; (2) How to guarantee the security of the wired and wireless communication in the home building since signal is relatively easily accessible to potential attackers; appropriate authentication and encryption are necessary in such cases; (3) How to tackle the interference of the signals and specifically overcome the background noise in case of power line communication.

There are several smart-home specific communication standards which were included in Table I. Generally speaking, two biggest standardization organizations are IEEE and ITU-T. The IEEE standards include the "HomePlug" presented in IEEE 1901 and WiFi which is presented in IEEE 802.11 protocol series. The ITU-T recommendations include HomePNA series from HomePNA alliance [171] and G.hn [172] series promoted by HomeGrid Forum [173]. These are important standards for home area network.

5.4.4 Net-zero Energy Building and Energy Efficiency at Home

The term "Net Zero-Energy Building (NZEB)" [174, 175] refers to the buildings that have their own energy generators to feed their energy demands. They are approximately with net zero energy dependence to the outside power grid on an annual basis. Limited by the availability of renewable energy sources and seasonality, most of these buildings are also connected to the grid and import energy from outside when the self-generated capacity is below the actual usage. In reverse direction, they can also export excessive power to the grid through a "buy-back" policy between the building owners and utility companies. But overall, the energy they generate and consume is even and contributes zero carbon emission to the environment on an annual basis.

The term "Net Zero-Energy Building" (NZEB) is different from the concept of "Green Building" [176, 177] in the sense that the key goal of NZEB is sustainability and they tend to have much lower ecological impacts compared with other buildings. Due to the current limitations of the renewable energy generation, net zero-energy goal is primarily feasible in small and medium size residential buildings where the energy demands are relatively low compared with large office buildings. For example, in Washington University, we have a Tyson Research Center net zero-energy building [178] which won the "Living Building Challenge" [128] award. It successfully realizes the annual net zero-

energy goal by generating energy through solar panels and with conservative energy designs and operations. It also has cooperation with utility company to balance the generation and consumption on an annual basis.

Residential NZEBs require installing clean and renewable energy harvesting devices using biofuel, solar panel, wind turbine, etc. They also try to minimize water consumption by appropriate recycle or conservation methods. Local and sustainable materials are used and the whole construction process also considers minimizing the environmental impacts.

5.4.5 Smart Thermostat at Home

Smart thermostat or HVAC is another in-home application area that potentially can simultaneously improve users' comfort and energy efficiency. The conventional thermostat is manually controlled and cannot be tuned automatically according to the weather conditions, occupancy, and owner's comfort. For residential buildings specifically, the HVAC system is light-weight compared with the large-sized commercial office buildings. Hence, applying more intelligent and human-based control to tune the indoor conditions to match the occupants' actual demands is easier. Currently, there are several such control systems available both in academic research [179, 180] and in real commercial products [181] that are built on top of the existing home based HVAC with relatively low cost. Internet-controlled capability allows the users to monitor the HVAC conditions from anywhere at any time through remote PCs or smart phone applications based on iPhone or Android platforms [181]. The HVAC running policies and schedules can also be reconfigured and controlled on air in real time. Moreover, some systems offer learning capability which analyzes the usage patterns of the owners, predicts their behavior, and develops an optimal running schedule for the thermostat. According to different goals, there can potentially be different modes like aggressive scheduling strategies best for energy efficiency or mild scheduling strategies best for human comfort.

5.5 Convergence of Intelligent and Green Technologies in the Building Environments

In this section, we discuss an important trend of combining the key concepts of green and intelligent buildings in creating "intelligent green buildings".

5.5.1 Definition

An intelligent green building is usually defined as better building designs and operation using both intelligent and green technologies. Specifically, on one hand, its design, construction, and operation are supposed to create minimum impact on the environment, to use resources efficiently and conservatively, and to create healthy and comfortable living and working conditions for the occupants. On the other hand, with intelligent technologies and integrated systems, intelligent green buildings provide monitoring and control functions to automate the running and maintenance processes and ensure efficient and fast operation. These functions can help the building owners and operators make better decisions in offering safe, healthy, and comfortable environments to the occupants.

The green building concept is combined with the intelligent building concept to advocate the prospect of sustainability with modern advanced information and communication technologies. Intelligent technologies integrate the whole building into a coherent structure and create interoperability and interaction among subsystems to make the building run cost-effectively and even profitably while providing a healthy living environment for the owners in the long run.

Moreover, another motivation of combining the "green" and "intelligent" aspects is to promote not only good building design but also efficient operation of the buildings. As indicated in our previous research results on the energy efficiency of the green building testbed [15, 16, 114], "green buildings" that are "green" by design do not always lead to energy efficiency in operation. Thus, one of the major motivations for the "intelligent green building" is to connect these two aspects and try to use intelligent computing and networking technologies to enable energy efficiency and saving during running and operation of the buildings.

5.5.2 Energy-efficiency and Sustainability Benefits

To be more specific, intelligent green buildings have the following features or design goals. These features are also the major motivating and driving factors for the convergence of green and intelligent technologies.

- **Automated Control and Running:** Latest control protocols and technologies can be applied in the new context to facilitate the initial "green" design goals.

- **Efficient Energy Utilization:** Empowered by the integrated networks with multiple devices and sensors connected to it, energy is utilized in the building more efficiently.
- **Healthy and Comfortable Environment:** Using intelligent and green technologies, buildings can provide occupants with healthier and more comfortable environment without negatively impacting the environment. Better in-building environment can also improve the occupants' life quality and productivity.
- **Renewable Energy Generation:** Green buildings can be installed with renewable energy generators like solar panels and wind turbines to supply their own energy usage as much as possible. Such methods can reduce energy dependence on the grid to some extent.
- **Easily Adaptable to Future Needs:** The intelligent system inside the buildings can be easily tuned to accommodate the new demands from the owners and occupants without significant renovation to the buildings.
- **Long-term Profitability:** Compared with conventional buildings, the initial costs of green and intelligent designs can be relatively high. However, in the long run, the intelligent green buildings should cost less ultimately. It may also result in economic gains (like better resale values for building owners) and help the facilities and organizations to realize their social responsibilities and sustainability goals. These benefits can be better evaluated by a Life-Cycle Cost Analysis (LCCA) [182].
- **Low Green-House Gas Emission and Sustainability:** There is a trend and possibility that in the future the legislative and regulatory responsibility of the climate change will be transferred to the energy producers and consumers directly [183]. Hence, building owners are also increasingly requested to bear the social and economic responsibilities to improve the business efficiency and energy efficiency. It is also an indispensable part of global sustainability efforts.

In short, combining green and intelligent building technologies and processes can bring a lot of benefits for owners and occupants not only in terms of convenience and efficiency, but also in terms of cost-effectiveness, long-term profitability, and maintaining the social responsibilities in sustainability.

5.5.3 Key Supporting Technologies for Intelligent and Green Converged Buildings

Some of the latest key supporting technologies include the following:

- **Integrated Communication Backbone.** As we discussed, integrated in-building communication backbone is a key component of the green and intelligent convergence. It allows the building owners and occupants to effectively monitor and control their energy and resource usage, and apply instant changes and adjustments to see the improvements. Integrated communication backbone also saves duplicated infrastructure costs and is very cost-effective compared with multiple independent and proprietary communication networks. The other one that is related to this aspect is the Fiber-to-the-Telecom-Enclosure (FTTE) technology which encloses multiple telecom media and introduces comprehensive saving and reduction in multiple costs.
- **Networked Electrical Architecture.** As with the integrated communication networking infrastructure, the electrical infrastructure can also act as an integrated center for multiple electrical appliances such as lighting, energy, and control systems. For example, instead of the traditional pipe and wireline based lighting system, nowadays such lighting system is with embedded control capability and is connected with networks. Such perspective helps create a building environment more closely around the people, and preserve and improve the ROI for the owner and managers.
- **Water Conservation Technologies.** Water shortage is a significant global challenge and water monitoring and control technologies can make a huge difference in attacking such challenge. By connecting the water meters and sensors and delivering data and control messages through communication and networking technologies, the building owners and managers are able to get a real-time and complete picture of the water usage and help end-users achieve better experience while harvesting benefits in sustainability.
- **Integrated AV System.** Integrated audiovisual (AV) technology in the green and intelligent buildings helps link multiple organizations and their devices together, which promotes the usability and the value of the green and intelligent buildings. It also helps provide better comfort for occupants and better facilities management for the building owners and managers. Conference rooms with AV features embedded can also connect many intelligent devices such as smart lighting

sensors and windows shading systems, remote digital control systems, and video conferencing systems, etc.

5.6 Key Issues and Trends Discussions

In this section, we discuss some key issues and trends for the intelligent building and building-side grid research, especially focused on the energy efficiency and networking perspectives.

5.6.1 Energy Proportionality of the Buildings

According to our research on the green and conventional buildings' energy consumption, the data analysis results show that the actual energy consumption on most of the existing buildings (regardless of whether they are green buildings or not) is not proportional to the actual usage [15, 17]. In other words, a large portion of the energy is wasted, especially during hours when the building is unused or underutilized.

In our research efforts, we propose a method inspired by the computer industry in creating energy proportional computers. Specifically, the original computers consumed the same amount of electricity regardless of whether they were busy running programs or not. This has changed in recent years when multiple new technologies emerged to enable the core parts of the computer like CPU to consume less energy when they are idle or underutilized. We investigate the computer systems and the buildings and find that there are some common essences that potentially enable us to apply some key technologies in energy-proportional computing into creating energy-proportional buildings. As a simple definition, ***energy proportional building is a building whose energy consumption is approximately proportional to the actual occupancy rate.***

We found that several basic methods and technologies in supporting the energy-proportional computing can be applied to the buildings. They include: (1) identifying the key energy-consuming components; (2) wide dynamic power ranges; (3) active low-power modes; (4) seamless transition among multiple running modes. With these features identified and appropriately incorporated into the building environment with the assistance of the advanced networking and information technologies, we can enable the key components of the buildings and their running and operation to be energy proportional to the actual usage. Specifically, we list the two different application areas about energy proportionality and compare the key aspects in Table 5.2.

Table 5.2. Energy proportionality key aspects comparison between two application areas: computers and buildings

	Energy-proportional Computing	Energy-proportional Buildings
Key energy-consuming components	CPU, memory, hard disk, etc.	HVAC, lighting, appliances,
Wide dynamic power range	CPU, etc. can consume energy in a wide and dynamic range, say, 1/10 to 1/3 of peak without significant performance degradation	Enable some key component to consume less power in idle or standby mode, hence, achieve wide power range.
Active low-power modes	CPU run at lower frequency mode without significant performance loss, and without transition to other modes	Enable the key components (e.g., the home HVAC system) to work with lower activity degree, but still in active.
Multiple running modes	CPUs are allowed to work in different frequencies and speeds, hence consume energy according to the actual workload intensity.	Enable the key components (like lighting) to work in different intensities and modes, and with automated policy transition.

A typical example of creating such energy proportionality in the building environment is in our work [15].

5.6.2 Human Behavior Factors

People's awareness to the energy consumption and their behavior inside the buildings has huge impacts on the energy efficiency of the whole building. All the automated systems using advanced technologies work around and for owners or occupants. Neglect or unfamiliarity to the systems can lead to low effectiveness and efficiency of the advanced intelligent systems in the buildings. For example, we notice that most people may not care too much about the energy consumption in their work places while being opposite in their own home buildings. If the intelligent technology is too complicated for them to operate, there will be high possibility that the systems will be under- or unutilized. We summarize the following several key factors that can impact the adoption of intelligent systems and hence energy efficiency inside the buildings.

- **Awareness.** The occupants or the building owners may not know in detail how much energy is consumed and how it is consumed. Hence, creating real-time data display applications for the stakeholders' online access can make them aware of the energy consumption before

improvement measures are taken. A study by Oregon Sustainability Center [184] shows that we can generally reduce the commercial building energy consumption by 10% if we provide occupants with their energy usage information.

- **Sensitiveness.** The building stakeholders may have different degree of sensitivity to the energy consumption. Methods associating such sensitiveness with the economic benefits may motivate them to take actions to actively interact with the intelligent systems in the buildings to improve energy efficiency and cut costs. Another study [185] shows that providing users with in-home display on their real-time energy usage helps reduce the energy consumption by 15%. It demonstrates that combining energy awareness and sensitiveness has a great potential in saving energy.

- **Participation.** Conventional buildings barely involve any participation from the general occupants hence the energy policies formulation and decision processes are out of the control of most of them. Intelligent systems with convenient methods encouraging the stakeholders' active participation in the energy saving process can be very effective and fruitful. For example, smart phone applications are good ways to encourage such participation. Typical positive results are proved by two sustainability efforts of "Green Cup" energy-saving competition [186] and "Green Lab Initiative" [187] at Washington University in Saint Louis.

- **Social Factors.** The energy consumption issue is not only about costs but also about environmental sustainability. Hence, saving energy and introducing intelligence in buildings also have social implications. Besides the long-term cost benefits, introducing intelligent building designs and certificates may help stakeholders improve their public images in term of social roles and responsibilities. Future social network based applications (like in Facebook or Google Plus) involving energy saving profiles may help the energy efficiency efforts in much larger scales and potentially has profound impacts.

In short, besides the advanced technologies involved in the intelligent buildings, human behavior of the stakeholders also has huge impacts on the adoption of intelligent buildings. Using technical and non-technical methods (such as smart phones) to enable and encourage the stakeholders to be aware of the energy issue, and to actively participate in the operation and decision process can make it

more effective in terms of saving energy and supporting global sustainability. Advances in the standardization and certifying organizations and activities can also magnify such benefits.

5.6.3 Networking Convergence and Interaction with the Grids

Using consolidated multiple network infrastructures with open standards and protocols to enable the intelligent buildings to operate as integrated and harmonious systems have become necessary. Such convergence trend reminds us of what had happened in the developing history of computer and networking areas in which the broad acceptance and adoption of the TCP/IP (Transmission Control Protocol/Internet Protocol) protocol suite [151] significantly expedited the successful deployment of the Internet. For intelligent building developments, we believe that a unified and broadly-accepted building automation protocol can similarly accelerate this process.

The convergence has several potential benefits: (1) it will reduce the initial construction costs and the maintenance costs; (2) reduce the complexity of the networks inside the buildings; (3) facilitate the automation and interaction among different subsystems.

Another important issue and trend, as mentioned earlier, is that future *intelligent buildings will not only act as end energy consumers but also energy providers*. In such cases, the buildings generating more energy than what they consume will feed the rest of the energy to the neighbored buildings or even back to the grid. This scenario is also called Distributed Generators (DG) and microgrid scenario in some other circumstances. In such prospect, the building-side intelligent systems will connect and interact effectively with each other and with the smart grid. Integrated with appropriate "demand response" and dynamic energy pricing strategies, the building stakeholders can achieve cost-effectiveness while the smart grid can realize optimization and efficiency in even larger scales.

5.6.4 Cloud Computing in Facilitating the Interaction between Consumer-side and Provider-side Grid

The Internet is a great example for comparison with the power grid. While the current Internet has changed from the previously relative simpler role of delivering information from one place to another, the recent dramatic developments of several Internet companies like Facebook, Google,

and Apple have dramatically changed the ways people acquire information and interact with each other, and deeply shape the new directions for future Internet evolution.

Particularly, besides the smart phone technology, the emergence of cloud computing technology is an important factor that can potentially lead to somewhat similar "paradigm shift" for the power grid. The current power grid looks more or less like the previous Internet in the sense that the grid just delivers the power from one place to another without too much advanced intelligence incorporated. Potentially, we find the following places that the cloud computing technology can make a difference in the energy efficiency of buildings and microgrids:

- **Cloud-assisted In-building Energy Monitoring and Optimization.** Using clouds to store energy consumption data and to carry out offline modeling computation will free the building owners and operators from tedious and expensive maintenance on all kinds of servers and devices. Moreover, clouds can interact well with the smart phone technology in creating user-aware and user-customizable energy optimization applications in the building environments, just as we have found in our research [16].

- **Cloud-assisted Energy Capacity Allocation and Optimization in Microgrids.** In the above discussion on distributed generation and microgrid trend, there is a potential demand of creating interaction and synergy among intelligent buildings in a neighborhood to optimize the energy generation and utilization in a local scale. Cloud computing technology is very scalable and its usage can be easily generalized from the in-building optimization into the microgrid optimization usage. Using clouds, energy generation and consumption information of multiple intelligent buildings can be shared and exchanged to create an optimized capacity allocation strategy to achieve maximum efficiency in the microgrids, or even "smart community" and "smart cities"[188] grids in the future. The conventional power grid can benefit by using the cloud computing technology for information sharing and data storage without bearing significant amount of construction and maintenance costs. Locally optimized energy allocation and consumption can help reduce the overall consumption and achieve cost-effectiveness across the whole smart grid. Specialized applications can be built on top of such cloud computing platforms with lower costs and faster development and implementation speeds.

5.6.5 New Opportunities in a Smart World

Recently, there is a very significant paradigm shift happening which is the mobile Internet trend. In this shift, smart phones/pads with GPS, various network connections (such as 3G/4G, WiFi, Bluetooth, etc.), and multiple sensors are becoming much more popular and potentially can be a very important part of the intelligent building technologies. For example, there are smart thermostat devices coming with iPhone or Android applications enabling common device holders to be able to monitor and control the appliances in the buildings. More than that, every smart phone has multiple sensors (such as location sensors) which can be used to create location-sensitive applications to improve the energy efficiency of the building by introducing interaction among multiple buildings [16].

Internet of Things (IoT) [189] concept and the development of Cyber-Physical Systems (including wireless sensor networks [152]) also produce new opportunities. For example, the wireless sensor based power meters [121] enable easy and cheap indoor power metering without wirings. It is easy to gather information, maintain, and reconfigure the networks. Low-cost small-sized smart tags can also be used to monitor the occupancy rate inside the buildings and the information can be further used in deciding the building control policies to save energy, provide best human comfort, and increase human productivity.

In the future, it is expected that more such devices and applications will emerge and come into the intelligent buildings or smart homes and change everyone's daily life. These new intelligent technologies can be embedded and applied into the conventional buildings to improve the energy efficiency, security, human comfort, productivity, coordination with the smart grid, and global sustainability.

5.7 Brief Summary

In this chapter, we presented a survey of the current research and development status of the intelligent buildings and microgrids in a combined perspective of energy efficiency and mobile Internet. It focused on the major related technologies as well as discussions on key issues and trends that can potentially motivate the adoption and revival of the area after a relatively long history of stagnancy. We have attempted to draw an overall picture of the research status in this area and to

discuss potential areas for further research that can potentially generate huge impacts on everyone's daily life as well as global environmental sustainability which is important not only for the current population but also future generations.

Chapter 6

Energy Consumption Data Evaluation and Analysis for a Networked Green Building Testbed

In this chapter, we focus on our major work on the evaluation and analysis of the energy consumption data we collected for a green building testbed. We use the findings to guide the further designs in applying networking technologies in the building environments to improve the energy efficiency and enable our vision of "multi-scale" energy proportionalities. The content of this chapter is based on our previous publications [15, 17, 114].

6.1 Introduction

Energy consumption in buildings is significant and energy efficiency for the buildings is vital for the environment and sustainability. According to a general survey about the buildings' impacts to the natural environment in United States, buildings are responsible for around 38% of the total carbon dioxide emissions; 71% of the total electrical energy consumption; 39% of the total energy usage; 12% of water consumption; 40% of non-industrial waste [116]. In the mean time, the costs of traditional fossil fuels are rising and their negative impacts on the planet's climate and ecological balance make it necessary for us to find new clean-energy sources and improve the energy efficiency in the buildings.

However, buildings are complex systems and many factors can affect the total energy consumption in different buildings. It is meaningful to find the major factors and patterns through modeling and

analysis for different types of buildings. Such results can be used to construct appropriate methods and strategies to improve the energy efficiency for both “green” and “non-green” (conventional) buildings. We summarize the research on the topic into three sequential key steps:

(1) Energy monitoring. The consumption and generation of energy are monitored and logged in different granularities including the whole building, floors, departments, labs, rooms, and even occupants.

(2) Energy modeling and evaluation. Through off-line modeling and evaluation, find the energy consumption patterns and factors that may influence the consumption and the extent of their impact.

(3) Practical changes and strategy adjustments. The modeling and evaluation results should be used to find the key energy components of the building, to apply modifications, and to devise corresponding strategies to reduce energy consumption.

In this chapter, we focus on the first two steps and also discuss some important issues and our thoughts on the third step. Our study is based on a new on-campus green building testbed. Unlike many other existing works that are based solely on simulations, our work is based on real measured data for a currently in-use building testbed.

The key contributions of the content in this chapter are that we: (1) present a unique green building testbed for energy efficiency experimentation, (2) find the short-period and long-period correlation patterns between energy consumption and the environmental factors such as temperature and humidity, (3) find the daily average energy patterns over a long period using regression modeling and analysis, (4) find the effect of occupancy by studying office hours and after hours separately and by studying summer and fall seasons separately, (5) identify the absence of “energy-proportionality” through a systematic evaluation and analysis, and (6) reveal the lessons we learned from the analysis and discuss our idea to create energy proportional buildings by following similar concepts from the computer industry.

6.2 Related Work

Research related to energy consumption measurement and modeling includes building energy simulation tools, climate effect modeling, and sensor networks based energy monitoring and analysis.

For building energy simulation tools, many of them take building parameters as input and estimate energy usage [116]. An example is “EnergyPlus” by the Department of Energy (DOE) to predict energy flow in buildings [117]. Overall, simulation software is relatively a cheap way for evaluating the building energy consumption without deploying a whole metering infrastructure.

There is also some research to find the relationship between building energy consumption and climate or weather condition through modeling [118, 119]. The related research consists of: (1) simulating the heat transfer processes and building structures (envelope, tree shelter, etc.) to find how the climate can impact building energy efficiency; (2) study of solar effects on heat and mass transfer and their impacts. A complete reference list of related efforts can be found at [120].

For sensor network applications in the building environments, the research relates to electrical monitoring or lighting monitoring in a lab or a floor level using sensor nodes [121, 122] (see the list at [120]). Wireless Sensor Networks (WSN) are used to sense and control the lights according to the detection results of the sunlight for a building based on human activities, to monitor the electrical energy consumption, to log the human activities and to adjust the HVAC (Heating, Ventilation, and Air Conditioning) working time to provide better comfort, etc.

6.3 Testbed and Methodology

In this section, we describe the testbed we worked on and present the methodology for the modeling and analysis.

6.3.1 Testbed Description and Features

Our testbed is a 150,875 square feet large office building constructed in 2010. It received a Gold certificate from LEED (Leadership in Energy & Environmental Design) rating system [123] by U.S. Green Building Council (USGBC) [124]. It adopts a series of energy efficiency and sustainability features. Figure 6.1 illustrates how the monitoring and storage network is structured in our testbed. Currently, the overall consumption and resource usage for the building are monitored and logged through a series of meters. The data are then transferred to the backend central storage server every 1 hour (some are 30 minutes) through wired network for future off-line data modeling and analysis using SQL (Structured Query Language).

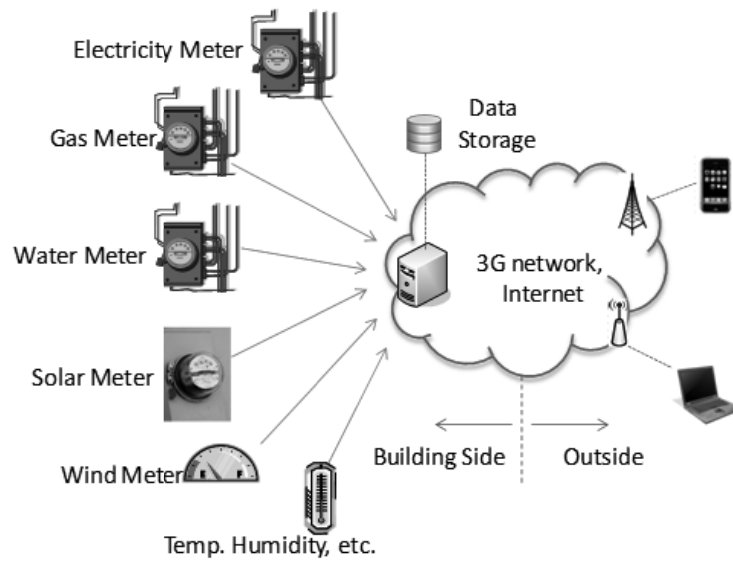

Figure 6.1. Testbed metering network and online real-time monitoring

From our discussions with the building management and maintenance staff, we know that it is a very *typical* large green office building with typical subsystems such as HVAC, lighting, and water systems. We believe that the experiment and further data analysis findings from this testbed apply to other large office buildings.

6.3.2 Data Source and Analysis Methodology

We studied the metering structure and sorted out the most useful measured data by analyzing the relationships among various parameters. Based on it, the data points that we make use of include: the total electrical energy consumption, the heating and cooling energy consumption, and the outdoor and indoor environmental data such as temperature and humidity. The heating and cooling parts can be deemed as the HVAC consumption while the total electricity consumption covers a wider range of loads in the building. Though separate lighting data may be useful, such data is not currently available. Moreover, the data mostly are semi-hourly or hourly logged data and we unify them to an hourly basis for uniform analysis.

Our primary modeling and evaluation goal is to identify the energy consumption pattern and know how it is related to: (1) the *environmental factors*, and (2) *the occupancy rate*. So, we first analyze the relationship between electricity, heating, and cooling energy consumption and the outdoor environmental factors. Our method is to combine the short period (longer than 1 day and less than

1 week) and the long period (several months) correlation analysis over hourly logged data to show the overall trends. We group the hourly data into multiple granularities such as weekly and monthly to reveal the complete correlation differences over a relatively long period. We also develop Multiple Polynomial Regression (MPR) model and Multiple Linear Regression (MLR) model to reveal longer term average seasonality trends. Moreover, to reveal the potential impact of the *occupancy rate to the building energy consumption*, we break the dataset into working hours and after hours and carry out detailed evaluation and comparison.

6.4 Evaluation and Analysis

In this section, we present the detailed modeling and evaluation results and the corresponding analysis.

6.4.1 Environmental Impacts Analysis

Here, we focus on the environmental factors such as temperature and humidity, and study their impacts on the total electrical and HVAC energy consumption.

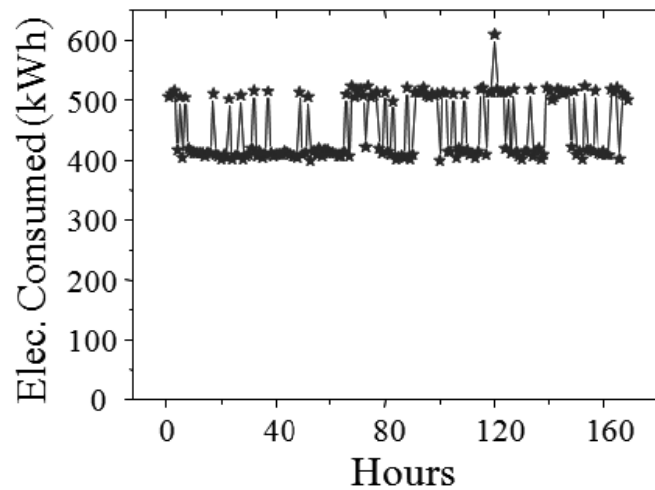

Figure 6.2. Total electrical energy consumption traces of 168 hours (7 days)

(1) Short Period Basic Trend Analysis

In Figure 6.2, we show the total electrical energy consumption traces for 7 days. We observe that the total electricity consumption toggles between 400kWh to 500kWh. After we consulted with the

building maintenance staff, we found that the electricity provision system is offering a coarsely redundant capacity and some major ON-OFF units may have caused the above pattern. Overall, the electrical consumption shows very little variation between days and nights, which means that *it possibly has a low correlation with occupancy*.

For heating and cooling, our testbed building uses two coordinated hot and chilled water loop subsystems to create the designated and comfortable temperature for every room. Heating data for the same period are presented in Figure 6.3 (due to the similar patterns between heating and cooling subsystems, in this chapter, we mostly focus on discussing heating data results). Note that in the figures we use the British Thermal Unit (BTU) as the unit for heating and cooling. 1 BTU is equal to 1055 joule or 0.293 watt-hours. In Figure 6.3, we approximately see 7 peaks. Periodicity of the heating energy consumption is conspicuous.

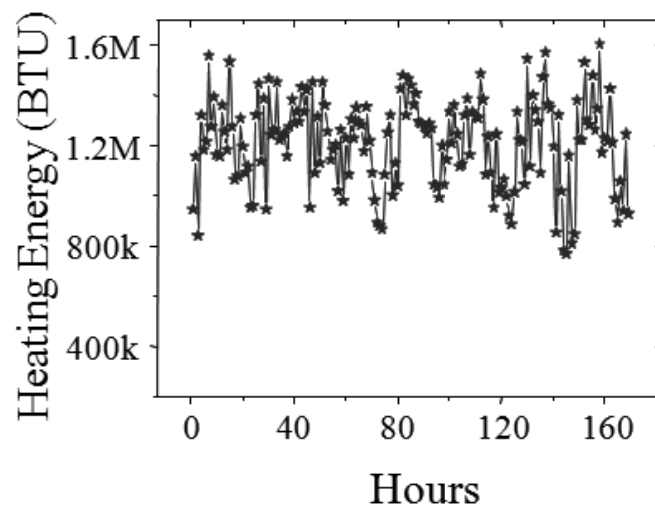

Figure 6.3. Heating consumption traces of 168 hours (7 days)

Observation: (a) The electrical loads cover a wide variety of appliances and some may be more correlated with environmental factors or occupancy than others. Hence, *tuning sub-systems such as HVAC, lighting, office appliance and other loads separately may help reduce energy consumption*. (b) *The heating and cooling sub-system is affected by the outdoor temperature more than electrical sub-systems*. We believe that it is mostly due to the way HVAC systems are designed for large buildings.

(2) Short Period Correlation Analysis

Our preliminary observation is based on the above two figures is that *heating and cooling are more correlated to the outdoor weather conditions than the total electric consumption*. To verify this observation, we visually inspect the simple correlation between the two groups of factors: (1) group 1 made of electric consumption, heating energy, and cooling energy; (2) group 2 containing temperature and humidity. We put them together to see if there is any conspicuous and straightforward connection.

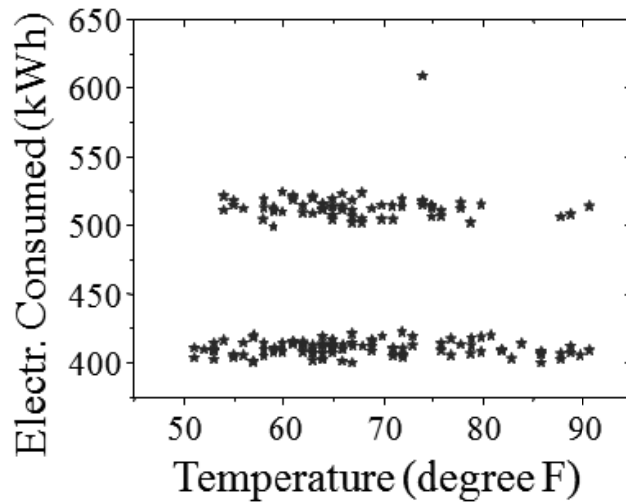

Figure 6.4. Total electrical energy consumption with temperature

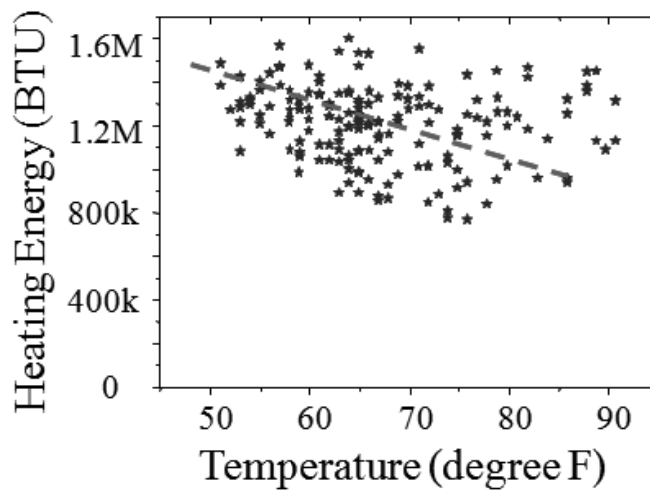

Figure 6.5. Heating energy consumption with temperature

Figure 6.4 shows the relationship between electrical energy and temperature. It shows little linear relationship. Figure 6.5 is the relationship between heating energy and temperature, in which we still do not find very strong linear relationship.

Observation: overall, heating energy is relatively more correlated to the outdoor weather conditions than the total electric consumption.

(3) Long Period Correlation Analysis

We now study the correlation among multiple factors over a longer period. After filtering out incomplete and inaccurate data, we get a continuous dataset for about 10 months (39 weeks). It ranges from 3/18/2011 to 12/31/2011. We group the data into weeks and every week has $24 \times 7 = 168$ data points. For each 168 data point set, we calculate the correlations among multiple factors. These factors include: temperature (denoted as X), humidity (Y), total electrical energy consumption (Z), heating energy (H), and cooling energy (C). We also mark the seasons on the timeline according to the Missouri climate convention.

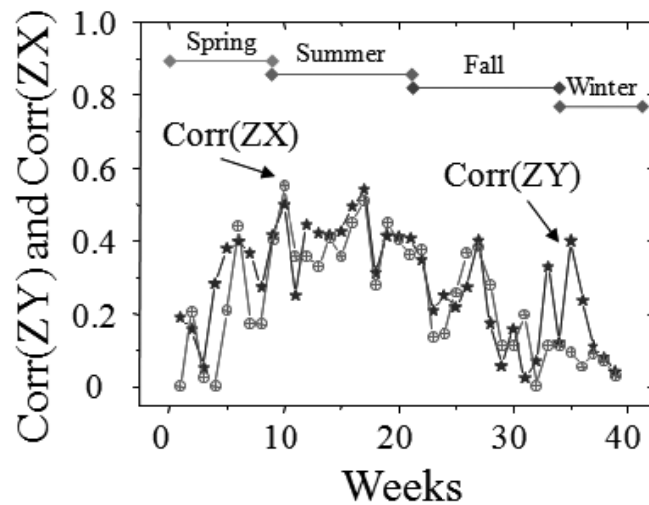

Figure 6.6. Correlations between electrical energy (Z), temperature (X), and humidity (Y)

The correlations between electrical energy consumption and weather conditions are shown in Figure 6.6. They are mostly below 0.5. Interestingly, the correlation for summer season is a bit higher than that for fall and winter seasons. The results validate the visual test results we got in the short period analysis presented earlier. Note that the X and Y in the figures do not mean x-axis and y-axis, but

temperature and humidity in our notation. The results for the correlations of heating energy with weather conditions are shown in Figure 6.7.

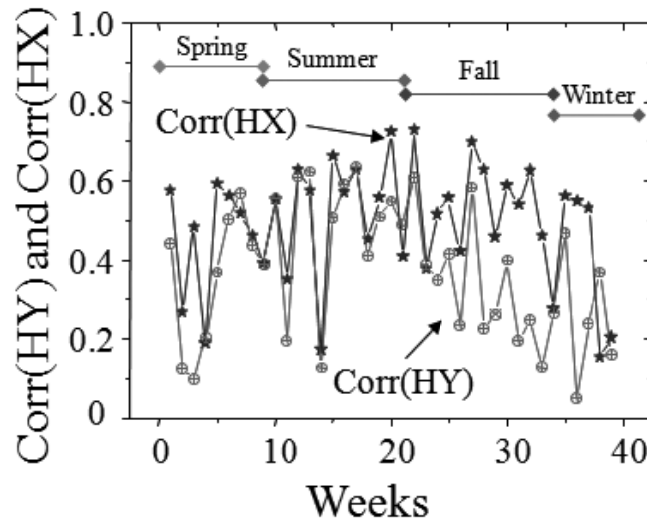

Figure 6.7. Correlations between heating energy (H), temperature (X) and humidity (Y)

Observation: the data analysis clearly shows that the *total electrical energy consumption has low correlation with outdoor weather condition*. Same applies to heating and cooling energy consumption. The figures roughly indicate that *the heating and cooling systems do not actively take the outdoor weather condition as factors to dynamically adjust the running schedule and policies to save energy*.

(4) Daily Average Data Analysis

So far, we studied *hourly* electricity, heating, and cooling energy data (1 data sample per hour). We also aggregate the data into *daily* averages to see if there are any new findings. Specifically, we calculate the daily average temperature and humidity, and the daily total electric, heating, and cooling energy consumption. By doing this, we have a data set for each day and a total 245 data sets for the period from 5/1/2011 to 12/31/2011.

The daily heating and cooling trends are shown in Figure 6.8. The seasonality is clear for both heating and cooling data in that there is more cooling and less heating energy in the summer. In total, for the above period, the energy usage is 8.1 billion BTU for heating and 16.9 billion BTU for cooling. It is interesting that the cooling system uses about *twice* the energy than heating. In the *summer months the cooling energy usage is significantly higher than that in other months*.

The daily electrical energy consumption trend is shown in Figure 6.9 in which we find a very regular fluctuation. The seasonality is not that obvious.

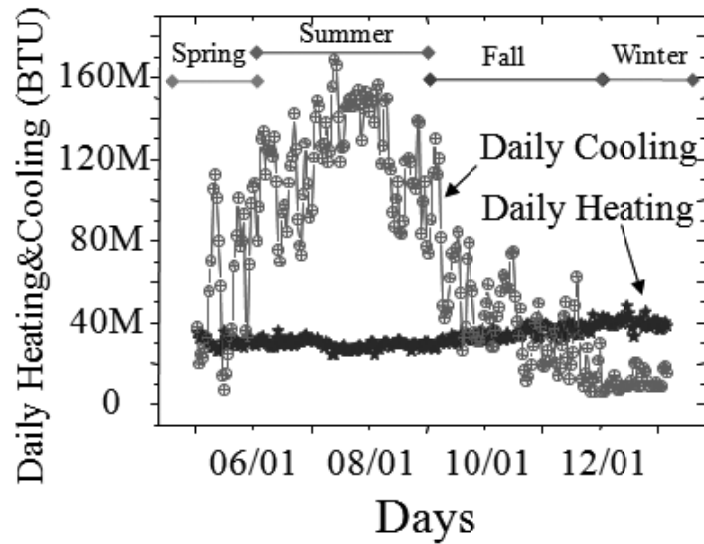

Figure 6.8. Daily heating and cooling energy during the specified period

Observation: the electricity provisioning in this building is relatively fixed and “extra capacity” is generally provided to satisfy any burst usage. *In other words, a lot of electrical energy is wasted, especially, during after hours.*

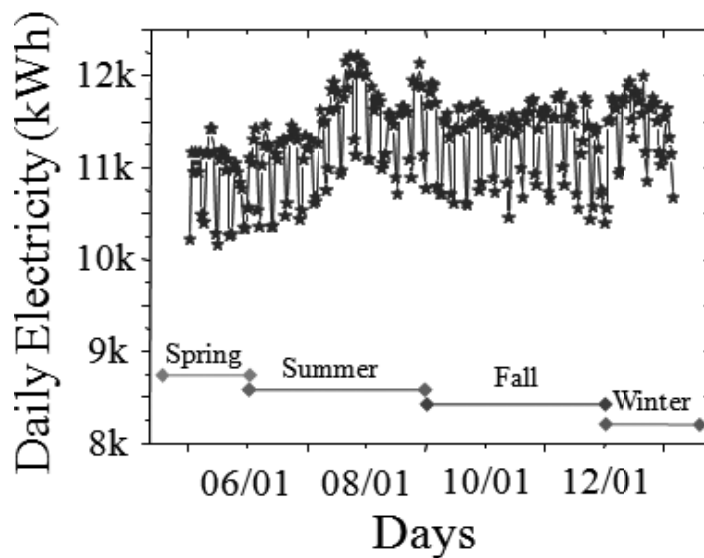

Figure 6.9. Daily electrical energy consumption

(5) Regression Modeling and Analysis

We further use regression models to analyze the relationship among multiple factors and observe the statistical results to see if they can justify the findings. We try both Multiple Polynomial Regression (MPR) and Multiple Linear Regression (MLR) models, and compare the two results.

First, we use the same daily average dataset and we have a vector of data point for each day. The vector is <daily average temperature, daily average humidity, daily electrical energy, daily heating energy, daily cooling energy> and we have 245 data vectors in total. We compute the coefficients of each factor in the two types of regression models, calculate the errors and conduct tests to check the effectiveness of the models.

Table 6.1. Regression results for electricity, heating, and cooling energy

	Electrical Energy		Heating Energy		Cooling Energy	
MPR	R²	0.1902	R²	0.8634	R²	0.9884
MLR	R²	0.0213	R²	0.8610	R²	0.9072

Table 6.1 presents results of the MPR and MLR on electrical, heating, and cooling energy predictions with temperature and humidity as two parameters. As shown in Table 6.1, the coefficient of determination R^2 is the fraction of the total variation explained by the regression [125]. For example, for electrical energy MPR, ***R^2 is 0.1902 which means that the MPR regression model can only explain 19.02% of the variation of electrical energy usage.*** In comparison, the R^2 value for cooling energy is 0.9884 which means that the ***MPR can explain 98.84% of the variation of the cooling energy consumption.*** This result validates our previous conclusion.

We also use 3D plots to demonstrate how well the regression models fit with the scattered plot of the measured values. The results for electrical and heating energy using MPR are shown in Figure 6.10 and Figure 6.11 respectively.

Observation: The regression model differences between electrical and heating energy clearly remind us that various energy subsystems of the buildings are impacted differently by the environmental factors; hence, for better energy efficiency, we should ***tune each subsystem separately*** as observed. For example, heating and cooling respond more to the environment and we may use environment condition to tune the running policy of the HVAC system and save energy.

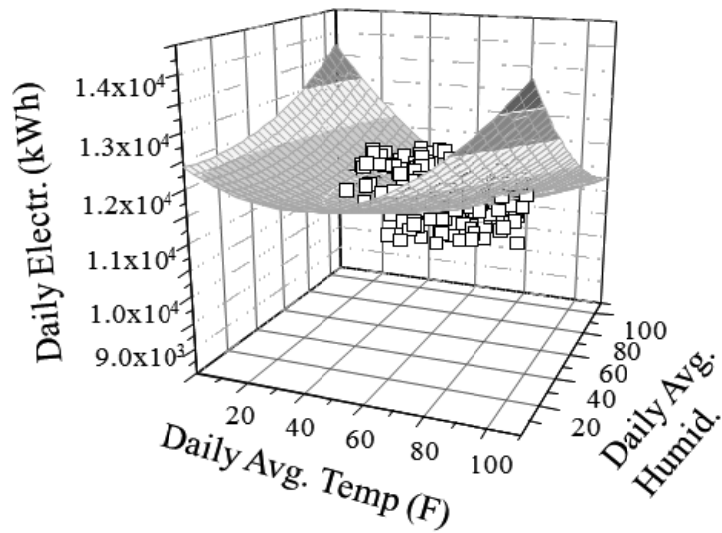

Figure 6.10. Daily electrical energy consumption MPR regression plane

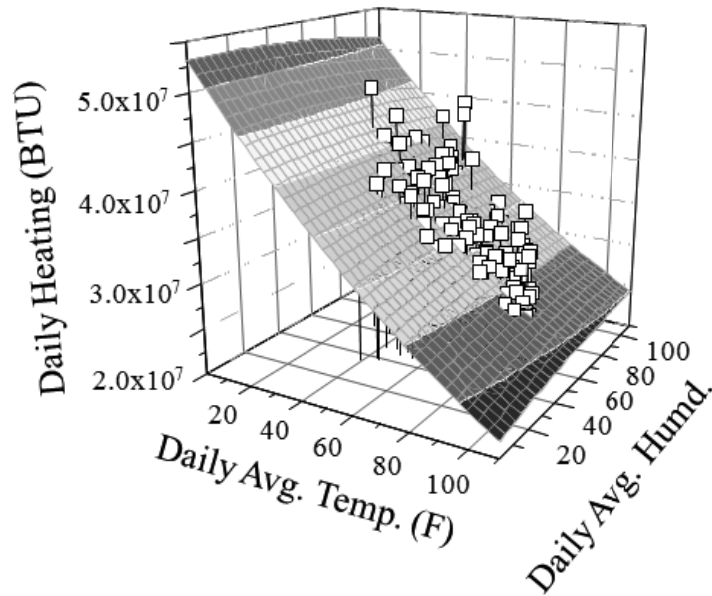

Figure 6.11. Daily heating energy consumption MPR regression

6.4.2 Occupancy Impact Analysis

In this section, we focus on the occupancy and study how it can impact the energy consumption.

(1) Weekdays/Weekends Energy Consumption Comparison

We roughly divide the data into three subsets: *regular office hours* (8:00am to 8:00pm of weekdays), *after hours* (8:00pm to 8:00am of weekdays), and *weekend* (whole days of Saturday and Sunday). We study the data by weeks and for every week we have three subsets. For every subset, we calculate their electrical and heating energy averaged in 24 hours, and compare them to see the differences. The results are shown in Figure 6.12 and Figure 6.13, respectively. From Figure 6.12, we can see that the electrical energy consumption during office hours is about 15% more than that for after hours and weekends. The numbers for after hours and weekends ***are not as low as expected*** which also illustrates that the current building operation is far from efficient and is not proportional to the actual usage or occupancy.

The heating energy consumption pattern, as shown in Figure 6.13 however, is a little bit different. Overall, the heating energy consumption for after hours is about 6% higher than weekends, and 19% higher than those for office hours. It is interesting to know that the heating consumption for the office hours is the lowest compared to the other two. It is probably due to the fact that ***the occupancy rate is higher during the office hours and more people are active and providing body heat in the building and hence reduce the external heating energy demands.***

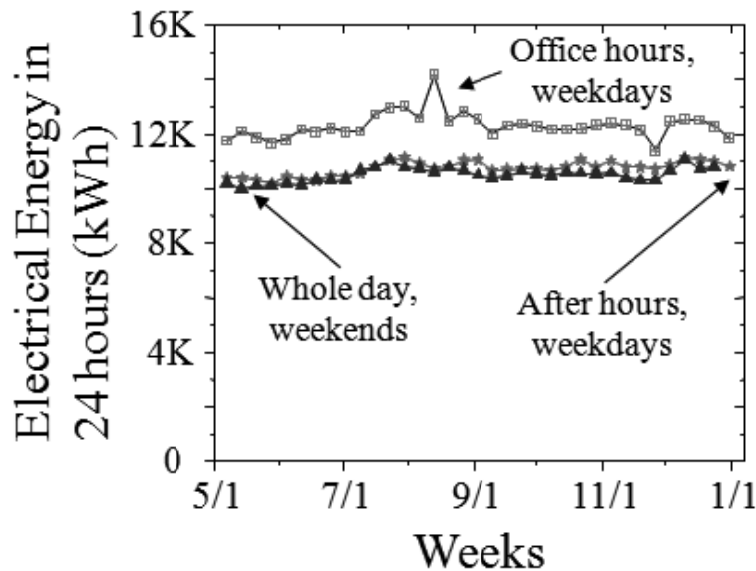

Figure 6.12. The comparison of electrical energy consumption averaged in 24 hours for office hours, after hours, and weekends

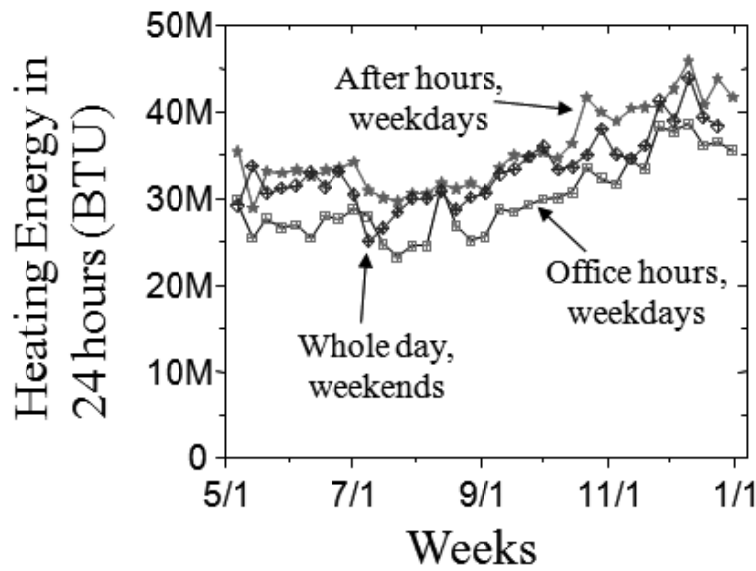

Figure 6.13. The comparison of heating energy consumption averaged in 24 hours for office hours, after hours, and weekends

Observation: the analysis clearly shows that the *actual occupancy rate has very low impact to the energy consumption*. Ideally, the numbers for after hours and weekends should be significantly lower than those numbers for office hours given that the main purpose and usage of the building testbed under investigation is for on-campus teaching and research.

(2) Correlation Comparisons: Weekdays and Weekends

We also want to see if the occupancy rates of various hours have different *correlation patterns*. For example, when usage is relatively high in the office hours, we want to see if the total energy consumption has more significant correlation to the environmental factors or not. Such analysis can help determine how occupancy affects the energy subsystems which can then be used for tuning the subsystems for better energy efficiency.

The results are shown in Figure 6.14. It consists of three sub-figures and each one is stacked with three curves. They illustrate the correlations among various parameters in different hours. Figure 6.14 indicates that different hours and hence *different occupancy rates do not have a very significant impact on the correlation patterns*. In the example of Figure 6.14, we only consider the temperature and similar results hold for humidity. Also note that some "broken parts" in some of the figures are because a small portion of data is missing for those weeks. However, this does not change the basic observation.

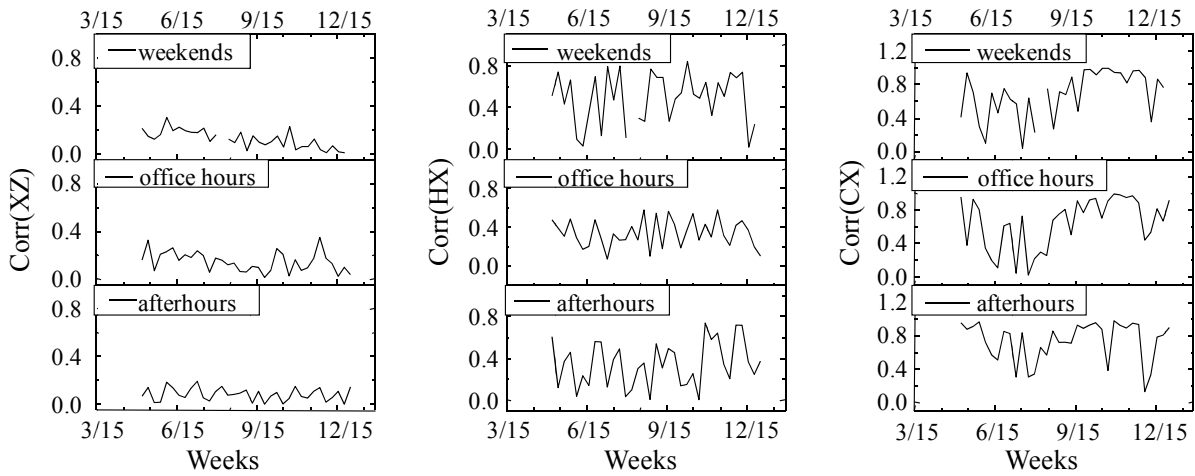

Figure 6.14. Correlation comparisons among office hours, after hours, and weekends. The correlations are $\text{Corr}(XZ)$, $\text{Corr}(HX)$, and $\text{Corr}(CX)$ from left to right respectively. (Z: electrical energy, H: heating, C: Cooling, X: temperature, Y: humidity).

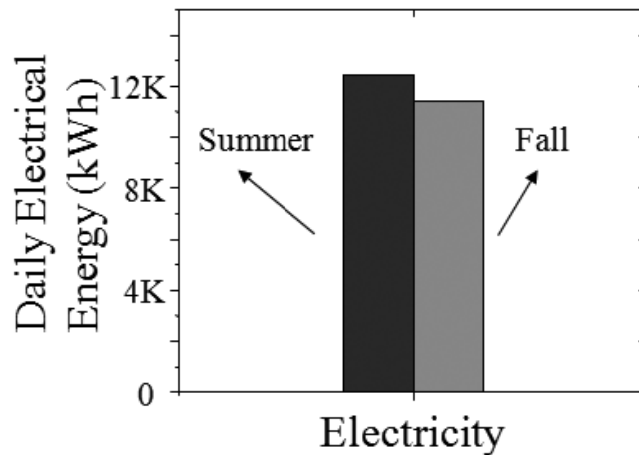

Figure 6.15. Summer and Fall daily electrical energy consumption comparison

(3) Energy Consumption Comparison: In-semester & Holidays

To further see how the occupancy rate can impact the energy consumption, we selected out the data for in-semester days and summer holidays and analyzed. According to the academic calendar of Washington University for year 2011, we pick the period between August 30 to December 09 (101 days in total) as the fall semester, and the period between May 10 to August 29 (111 days in total) as

the summer holiday season. Generally, the summer holiday season has lower occupancy rate as the regular fall semester in our testbed building.

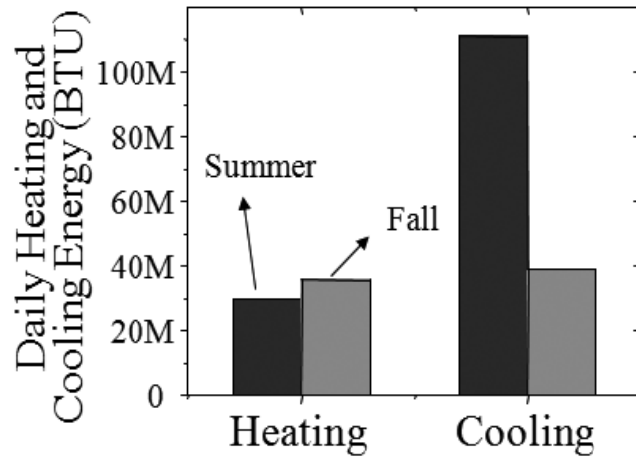

Figure 6.16. Summer and Fall daily heating and cooling energy consumption comparison

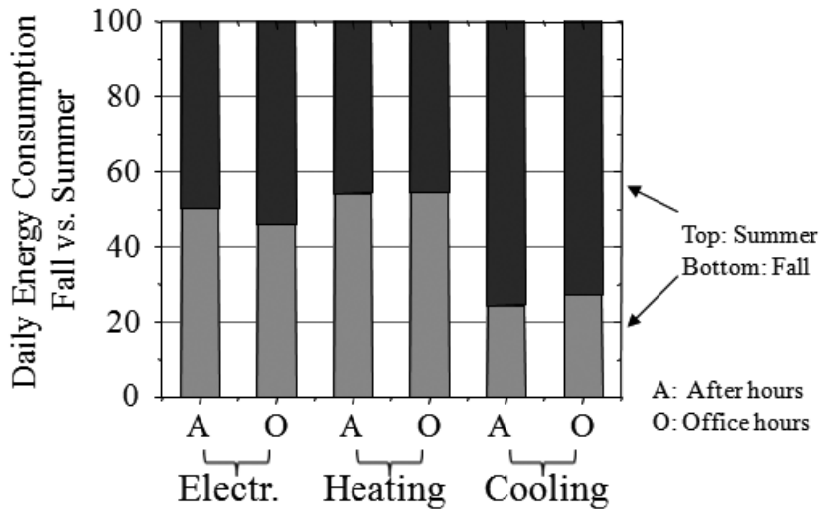

Figure 6.17. The daily energy consumption comparison between Summer and Fall, considering after hours and office hours

Firstly, we compute the total electrical energy consumption for the above two periods and average them by the days. The results are shown in Figure 6.15 which indicates that the electrical consumption varies very little for these two periods. Specifically, the summer season daily electrical

usage is about 8.8% higher than fall season. We also compared the heating and cooling energy consumptions which are shown in Figure 6.16. Daily average heating energy of the fall season is about 20% higher than summer, while daily cooling is 65% lower than summer season. Such results are consistent with the analysis results of the previous several subsections. If we separate the two periods into office hours and after hours, then we have a more detailed view of the energy consumption patterns. As shown in Figure 6.17, we scale the daily energy consumption in Y axis into a 0 to 100 range. We find that for electricity usage during after hours, it is almost fifty-fifty between summer and fall seasons, while summer is a little bit higher than fall for office hours (first two columns in Figure 6.17). Summer and fall heating energy are almost even for both after hours and office hours (middle two columns in Figure 6.17). After hours and office hours have also close cooling energy consumption (the 5th and 6th columns in Figure 6.17).

Observation: the comparison in different granularities shows that there is **no *direct and visible connection between the energy consumption and the occupancy rate***. In other word, a lot of energy is wasted regardless of the actual usage. More detailed office hours and after hours' separation in the two seasons confirm our observation.

6.5 Energy Modeling Discussions

In this section, we summarize the observations in our testbed, and discuss our perspectives.

6.5.1 Observations Summary

In summary, we found that even a green building may consume more energy than necessary. In other words, ***the energy subsystems' running and operation may not be smart and efficient***. A green building may **NOT** be an energy-proportional building even though it may have a LEED gold certificate [123]. The centralized heating and cooling control, and fixed running policies for such large office buildings are probably the main reasons to blame.

Given the situation we found in our green building testbed, it is also expectable and understandable that for the huge amount of existing conventional buildings, the proportionality issues are more conspicuous and serious. For residential and small office buildings, we do believe that more options are available to improve the efficiency since the buildings are less complex and easier to be controlled and adjusted to be energy efficient.

6.5.2 Energy Proportional Buildings: A New Concept Derived from Computer Industry

By definition, *an energy-proportional building is one in which the energy consumption is approximately proportional to the usage and occupancy*. We came up with this term based on “Energy Proportional Computing,” which is currently very popular in the computing industry. In the past, computing equipments consumed the same amount of energy regardless of load. New CPU designs are such that they consume little energy when idle and the consumption increases with the load. This leads to significant energy savings since the computers are mostly idle. We believe it is possible to apply this concept of energy proportionality to both new green buildings and conventional buildings. Several observations from the computer industry include:

(1) Major Components. The major energy-consuming components of computers are the processors (CPUs), disks, memory, and external devices. For buildings, we also have energy-consuming components such as: HVAC, lighting, and other electrical appliances and loads. For big office buildings, the HVAC systems may be a counterpart of CPUs. After successfully identifying the key energy-consuming components for a specific building (key components may vary for different types of buildings), the key parts can be redesigned or reprogrammed to be smarter, to be able to work in several gears, and dynamically adjust the running schedule with different energy consumption rates.

(2) Running Modes. Mobile smart devices and embedded devices like sensor network nodes mostly work in a bimodal mode to save energy. They require high performance for short period followed by relatively longer idle time in standby or sleep mode. The cases for servers are different whose CPU utilization usually is between 10% and 50% of maximum and can rarely be in sleep or idle mode for a long time. For the building environments, we can also consider different cases. Big office buildings are rarely in completely idle or standby mode since it is possible for some occupants in the building working overnight. Thus, considering both costs and benefits in such cases, we may tune energy-saving to focus on lighting or other appliances first. For small-office or residential buildings, however, the lessons from the mobile devices can certainly be more helpful. The buildings can have a dynamic and flexible running schedule and put the small HVAC and appliances to standby and idle modes more aggressively. Dynamic switching among modes helps reduce the energy consumption significantly just as in mobile devices.

(3) Processors' Features. There are two key CPU features that can be used in creating an energy proportional building: “*wide dynamic power range*” and “*active low-power modes*” [126]. CPUs nowadays have wide power ranges. Desktops and server processors can consume less than 1/3 of the peak power at low activity modes. Mobile devices can reach 1/10th of peak power. This means that the processors can consume energy in a very wide and dynamic range. The feature of “active low-power modes” means that the processors can run normally in **ACTIVE** low-power mode instead of complete standby or idle mode. In the building environment, frequent switching from active to standby or sleep modes may introduce significant extra costs especially for big office buildings. Applying such “active low-power modes” feature in building could avoid the transition penalties while maintaining the active status. Key components like HVAC in the buildings can be tuned to offer somewhat similar features like energy-proportional computers by adjusting the running policies dynamically [16] and consume less energy.

6.6 Nine Lessons Learned from the Green Building Testbed

In this section, our primary focus is to summarize the lessons we learned from the testbed and to find potential implications for future designs and implementations of more intelligent and energy-efficient buildings. It is worth mentioning that we are investigating from an energy efficiency perspective, though there can also be others related to building design, construction, material usage, and life-cycle sustainability. We also put the issue in a larger scale, i.e., in consumer-side power grid scale which is beyond a single building's scope. We believe that such perspective is important for a future world of smart grid. The major contribution of this section is based on the paper [114].

6.6.1 Lesson #1: Centralized and fixed-pattern control leads to less flexibility and efficiency in conventional buildings

We investigated a series of buildings in our campus including our green building testbed and find that most of them incorporate centralized control designs for the subsystems such as HVAC (Heating, Ventilation, Air-conditioning, and Cooling), lighting, safety and security, and other appliances and subsystems. Multiple buildings share a centralized subsystem. Also, there is almost no interaction or synergy among these subsystems. For example, the running schedule of HVAC system

usually does not work together with the safety and security system. It does not make use of recorded occupancy rate and activities information to adjust the running schedule, and the HVAC system almost consumes fixed amount of energy regardless of the real usage at different working hours. In other words, multiple subsystems run individually in a fixed pattern and there are very few or even no efforts to integrate them into a coherent system to gain better energy efficiency and realize real automated operation.

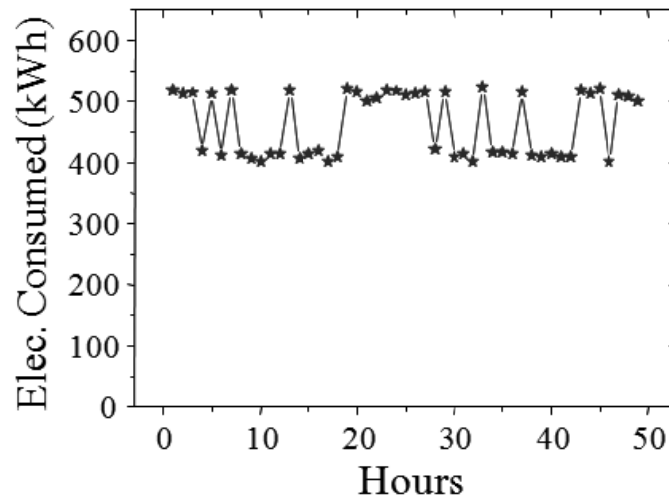

Figure 6.18. Total electrical energy consumption traces of 48 hours for our testbed building

Particularly, in our testbed, we recorded energy consumption data for almost one year and studied the energy consumption pattern. We studied both short-term and long-term correlations between two groups of parameters [15]: one is the energy consumption parameters such as electrical, heating, and cooling energy consumption; the other group includes environmental factors such as temperature and humidity. The data modeling and analysis results show very low correlations among these two groups of parameters. For example, some simple electricity consumption traces for 2 days are shown in Figure 6.18. We can see that for these periods, the consumption toggles between two values and the patterns show little direct and clear correlation with the office and non-office hours. We discussed this with the electricity system maintaining technical staff of the building and found that the electricity provisioning systems offer relatively fixed pattern which includes redundant capacity and introduce little variation among different hours. We also find that this is not a special case, but a common method for most buildings in a campus.

To summarize the lesson we learn in this regard, we find that to enable the electricity consumption to be more correlated to the actual usage for better energy efficiency, we need to change the centralized control and fixed-pattern running mode into distributed control and dynamic switching among multiple running modes. Distributed control enables different building sections and subsystems to run as relatively independent systems and to adjust their own running policies and schedules to save energy based on actual usage or occupancy rate. Multiple running modes and dynamic switching among them make the energy provision match the actual demand actively, and the building system can be more flexible.

The economic potentials of doing this can be huge for several reasons. First, for single building, most of the energy waste in non-office or non-active hours can be avoided. Second, a large number of conventional buildings can benefit from it and the total economic benefits in a larger scale can be very significant. Third, distributed control and interaction bring more opportunities for various software and hardware vendors to work together, which potentially expedite the process of protocol standardization.

6.6.2 Lesson #2: Energy Harvesting cannot replace Energy Conservation

Energy harvesting means that the buildings are installed with renewable energy generators to provide alternative energy sources other than from the power grid. Typical energy harvesting facilities include solar panels, wind turbines, geo-thermal generators, biomass generators, etc. Energy conservation means that the building is installed with intelligent energy-saving devices or systems, or applied with specific policies to control the energy consumption and avoid waste. In the efforts of making buildings more efficient and reducing energy dependence to the outside power grid, these two mechanisms can usually collocate in a specific building.

Our testbed office building has solar panels and wind turbine on the roof. We found that the energy generated by the energy harvesting devices contributes less than 0.1% of the total energy consumption in this testbed building. Though the percentage can be a little bit higher for small and medium sized residential buildings, we find that it is not a good or cost-effective idea to just spend a lot of money installing as many solar panels as possible to cover the total energy consumption. Instead, we find that much of the energy in the building is wasted due to a series of reasons. For

example, the centrally controlled and fixed running policy of the HVAC system leads to at least 50% of the total energy waste, especially in the non-office hours of weekdays and in the weekends. Also, lighting and other public electrical appliances in the buildings are mostly without intelligent and dynamical control mechanism which contributes to a part of the waste.

Comparing the two sides of energy harvesting and energy conservation, we find that given the current status of the energy efficiency in various buildings, it is reasonable to focus more on the energy conservation than energy harvesting efforts. There is significant room for energy conservation by reducing energy waste by applying some simple energy conservation policies or strategies. It is generally much cheaper than buying energy harvesting renewable energy generators to feed the gigantic demand and to cover the high energy consumption which includes a huge amount of wasted energy. In short, energy harvesting cannot replace energy conservation in our opinion.

6.6.3 Lesson #3: Building sections partitioning technology is necessary for building-level energy efficiency optimization

As shown in the data analysis results in our previous modeling and analysis work [15], for the building as a whole, it is difficult to set up strong correlation between its total energy consumption and the environmental factors and occupancy rates. The reason we find is that building is a very complex system, and its separate sections and subsystems may demonstrate very diverse energy consumption patterns and have different correlations with related factors, and hence demonstrate various rooms for potential improvements. If we sum up all the energy consumption data and study them as a total number, we may lose a lot of useful information.

Thus, we coin a term of "deep building partitioning" technology to reflect our idea that we may study building's subsections and subsystems separately. We can study the energy consumption of these systems and model their correlation patterns individually. It will enable us to know which sections or subsystems can be adjusted according to the actual weather condition and which sections or subsystems can be adjusted based on the real occupancy rates. Then we can apply networking and computing technologies to these subsystems to gain best results out of limited resources. For example, for the lighting subsystem, its real electricity consumption will be highly correlated with the occupancy rates in the building. Thus, we may apply related technologies to automatically turn off some or most of the devices during non-office hours or week-ends. Similarly, for HVAC systems,

especially the small-sized HVAC systems for small and median resident buildings, their running schedules and strategies can be formed considering the weather conditions to achieve optimized energy consumption. Such ideas can be generalized to multiple types of buildings. Due to the diversity of buildings and various appliances in them, it is necessary to do such deep building partitioning based on each actual building before achieving optimized energy results for it. Generally, we divide this deep building partitioning technology into three key steps:

(1) Partitioned energy monitoring. Building subsystems and subsections are monitored separately and their energy consumption is logged for offline modeling to find their correlation patterns for further consideration.

(2) Separate energy modeling and analysis. The goal of this step is to find energy pattern for each subsystems and subsections that can potentially be adjusted to save energy.

(3) Applying changes using networking and other technologies. Based on the modeling and analysis results of the step (2), we will know which subsystems and subsections can achieve best energy saving if we apply limited networking devices. Then we can devise the strategies for each subsystem or subsection to achieve optimization for a whole building.

6.6.4 Lesson #4: Buildings should be designed and operated to be energy proportional

We know that buildings are complex systems, and it may be difficult to enable them to have simple and straightforward correlation with specific parameters. However, built upon the deep building partitioning technology, it is possible to enable the buildings to achieve best energy saving with limited resources. In other words, we may achieve "energy proportionality" to the actual usage or occupancy.

There are two incentives to achieve this goal. First, energy consumption in buildings is a billion-dollar problem and making them more energy efficient is of significant economic meaning as well as social implications in terms of promoting global sustainability. Second, by implementing the idea using networking and computing technologies, the buildings can be turned smarter, and will serve people better and provide more advanced features that are not possible before.

To achieve such energy proportionality, we propose to learn from the history of computer development. The original computers were designed consuming constant amount of energy

regardless of whether they were busy or idle, which caused significant waste of energy. Nowadays, the computers, especially the CPUs inside are designed to be energy proportional and consume significantly less energy when they are not busy. Thus, we propose to import this concept to the building environment. Given the significant amount of energy consumed in the building environment, if we are able to create such energy proportional buildings and apply the related ideas to a wide range, then we can potentially save billions of dollars. Thus, such technologies can be of both technical merits and economic impacts to the society.

We study the key methods and technologies in energy proportional computers. Particularly, we find that the following two features of energy proportional computers [126] can be imitated in buildings to enable an energy proportional building.

(1) Identifying the major energy-consuming components in buildings. In computers, the major energy-consuming components are CPUs, memory units, etc. Making them energy proportional is an important step to enable an energy proportional computer. Similarly, for energy-proportional buildings, we need to identify the major energy-consuming subsystems and subsections, and adjust and change their running policies or strategies to make it energy proportional.

(2) Enabling the key components to work in multiple active running modes with different energy-consuming rates. One of the key technologies of the CPUs in energy proportional computers is that it allows the CPUs to be active but working in different intensity and hence consuming less energy than conventional CPUs. Similarly in the building environment, after we identify the key components, we can apply networking and other computing technologies to allow the key components to work in a smarter way and to be able to switch between multiple active running modes according to the real occupancy rates or usage conditions.

6.6.5 Lesson #5: Enabling multi-scale (organization or user-level) energy proportionality using networking and computing technologies

A more aggressive goal than creating energy proportional buildings is to create multi-scale energy proportionality. It means that the energy proportional perspective can be realized at multiple granularities. In other words, by applying a series of networking and computing technologies, we

may be able to allow not only building level energy proportionality, but energy proportionality for any scale, for example, a single user or a specific organization.

A typical example to achieve energy proportionality for a single user is applying networking technology based on smart phone with location-sensor to create a platform allowing users to automatically and dynamically control or adjust their own energy usage policy and profile across multiple buildings [16] in real time or according to their current locations. By doing this, users will be able to consume optimized amount of energy according to their real demand and usage. The individual user may have to follow the energy policies enforced or required by a larger affiliated organization such as a company or department in university. Hence, as long as individual users in a specific organization use applications like this, the energy proportionality for this organization can be achieved. Similar policy structure and policy enforcement can be applied to many other scales to achieve multi-level energy efficiency optimization goals. The details of how such energy saving policies can be negotiated and formed can be found in our previous system framework design paper [16]. A simple comparison of the concepts of energy proportionality in multiple granularities can be found in Table 6.2.

Table 6.2. Comparison of energy proportionality concepts in multiple granularities.

	Computer	Building	User	Organization
Identifying Major components	CPU, RAM, etc.	Key subsystems such as HVAC or electrical appliances	All components under the user's control	All components under the organization's automatic control
Key idea	Dynamic running mode changes	Networked monitoring and control; Real time dynamic energy policy adjustment; Location based mode switching and control		
Key enabling technologies	1. Multiple active running modes for CPU	1. Apply active running modes to key appliances	1. Direct monitoring and control	1. Multi-scale energy policies enforcement under its realm
	2. Wide energy adjustment range	2. Allow dynamic control based on real usage	2. Dynamical adjustment based on location	2. Aggregate the building and user energy proportionality

There are several major benefits of realizing such multi-scale energy proportionality. The first one is the economic benefit. Apparently, a huge amount of energy waste can be avoided in multiple scales, and the total effects can be accumulated to a significantly large amount of energy savings for a specific region or country. The second benefit is that we can achieve better organization-based control and better representation of their existence. In other words, these organizations can design and enforce their own group energy-consuming policies and achieve optimized energy usage in their own territories. They can also play more important roles as high-level energy policy related strategy makers.

6.6.6 Lesson #6: Actively involving occupants and stakeholders' awareness and participation can make a huge difference

With the proposed idea of involving smart mobile location based network control, we can greatly promote the broad awareness and participation in the energy efficiency efforts. People's awareness of the energy consumption issue and their behavior inside the buildings has huge impacts on the energy efficiency of the whole building. All the automated systems using advanced technologies work around and for the people or occupants. Neglect or unfamiliarity to the systems may lead to low effectiveness and efficiency of the advanced intelligent systems in the buildings. For example, most of people may not care too much about the energy consumption in their work places while on the contrary they may care more at their own homes. If the intelligent technology is too complicated for them to use, there will be a high possibility that the systems will be under- or unutilized. We summarize the following key factors that can influence the adoption of intelligent systems and hence energy efficiency inside buildings.

(1) Awareness. The occupants or the building owners may not know in detail how much energy they consume and how it is consumed. Hence, creating real-time data display applications for online access can make the stakeholders aware of the energy consumption before improvement measures are taken. A study by Oregon Sustainability Center shows that the commercial buildings' energy consumption can generally be reduced by 10% if occupants are provided the energy usage information.

(2) Sensitiveness. Building stakeholders may have different degrees of sensitivity to the energy consumption issues. Methods associating such sensitiveness with the economic benefits may

motivate them to take measures to actively interact with the intelligent systems in the buildings to improve the energy efficiency and save costs. Another study shows that providing users with in-home display of their real-time energy usage helps reduce the energy consumption by 15%. It demonstrates that combining the awareness and sensitiveness has a great potential in saving energy.

(3) Participation. Conventional buildings involve very little participation from the general population hence the energy policy and decision are out of the control of most of them. Intelligent systems with convenient methods encouraging the stakeholders' active participation in the energy saving process can be very effective and fruitful. For example, smart phone applications [16] can be used to encourage such participation. Two green efforts of "Green Cup" energy-saving competition and "Green Lab Initiative" in Washington University have confirmed this.

To summarize, if we can actively involve occupants and stakeholders' awareness, sensitiveness, and participation for the energy saving efforts through multiple policies, facilities, and activities, we can make huge difference in terms of reducing energy waste and improving energy efficiency for both individuals and organizational groups in multiple scales. It also means a lot for social sustainability.

6.6.7 Lesson#7: Integrating social behavior and activities in sustainable education tools may have a huge impact

Energy consumption is an issue not only about cost but also about environmental sustainability. Hence, saving energy and introducing intelligence into buildings also have social implications. Besides the long-term cost benefits, introducing intelligent building designs and certificates may help the stakeholders improve their public images in term of social roles and responsibilities. Future social network based applications involving energy saving profiles may help the energy efficiency efforts in a much larger scale and potentially have profound impacts.

To be more specific, we propose to take advantage of the smart phone and location service based idea [16] by designing and implementing a sustainability education tool with social network plugin (such as Facebook, Twitter, and Google plus) on the top of the smart-phone based energy monitoring and control application. A simple illustration of the concept is in Figure 6.19. By creating a bridge between the energy monitoring/control modules and the social network module on the smart phone platform, and facilitating their interaction, we may be able to create extra incentives and motivations for every common energy user to know the energy consumption issue and participate in

the global sustainability efforts, taking advantage of the fast and effective information propagation of the social networking applications. For example, a specific smart phone holder may post their energy profiles and energy-saving data through social network applications, influence other people's energy consumption habits, propagate good energy and sustainability concepts, and encourage everyone to participate in this global effort. Online social sustainability related activities may also benefit from such platform.

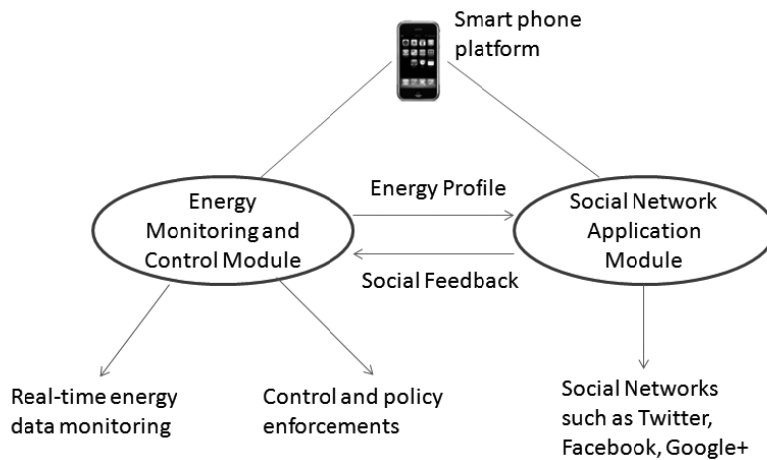

Figure 6.19. Bridging energy monitoring and control with social network applications

There are two major forms that we can use the tool for wide-scale sustainability education. The first is through online social network dissemination and propagation as discussed above. By doing this, sustainability education can be carried out in every occupant's real everyday life and their social behavior can affect those who are in their social network connections. The second form is through online or offline sustainability related competitions or social activities. The effects of competitions can be magnified by social media and everyone's social behavior. The proposed idea builds upon our previous successful experience, and the new socialized idea may achieve even broader impacts. The potential for commercial applications is expected to be big if the proposed goals are realized and turned into real commercial products.

6.6.8 Lesson #8: Create synergy among multiple intelligent buildings to enable optimization in a larger (microgrid) scale

The importance of energy independence at multiple scales has been proven in the history of massive electricity blackouts internationally and their corresponding costs. The concept of microgrid [127] is

to promote such energy independence. It promotes generating energy especially renewable energy (such as solar, wind, fuel cells, etc.) as near consumers as possible in a small-scale geographic area. The distributed energy generators provide a reliable and inexpensive alternative to the local consumers especially during peak time or even in the case of electricity blackout. The costs and risks of long-distance energy transmission and delivery are also reduced. Microgrids are very friendly to environmental sustainability due to the savings they introduce and the renewable energy generation they promote. Currently, microgrid concept is still in its incubation stage, and it is mostly restricted to the energy backup sources in small scale and lacks mechanisms and designs for smart dynamic allocation and scheduling among multiple sources.

For sustainability, we envision that in the future, buildings will not only act as sole consumers of the power grid, they will also become sources of energy, given the fact that more and more new buildings are now being installed with renewable energy generators such as solar panels, wind turbines, and biofuel-based energy generators. "Local generation, local consumption" policies can significantly reduce the energy dependence of the grids from different scales. By using smart-phones and cloud computing technologies to allow microgrids to dynamically monitor, schedule, and allocate generation and consumption capacities, significant amounts of power transmission loss can be saved. With such optimization, peak energy demands can be reduced, potentially saving a lot of infrastructure investment in the construction of power plants. In short, it is of high significance in terms of sustainability to enable innovations at microgrid scale.

Hence, from a technical perspective, we identify several key components for possible innovations in this theme:

- (1) Network the buildings and create a central knowledge plane;
- (2) Optimized allocation and distribution of generated energy;
- (3) Smart prediction and balanced energy delivery.

A conceptual illustration of this scenario is shown in Figure 6.20. We propose to network neighboring buildings in a microgrid such that each building becomes an "Autonomous System" (AS) monitoring its own energy and interchanging real-time consumption and generation capacity information with neighboring buildings as well as a central knowledge server. Each building has a monitoring agent, a policy agent, an interaction agent, and a control system implementing agents

that network together to achieve multiple functional optimizations. It virtually creates a central "knowledge plane" in a central server for the microgrid which is in charge of communicating with the agents of multiple buildings to collect real time information through distributed networking and dynamic scheduling of the energy capacity of the microgrid. Individual buildings work in a distributed manner as well as interact with the central server without creating "single-point-of-failure" even when the central server is down. In Figure 6.20, the top part is a network topology corresponding to the bottom physical building distribution. We can see that each building actually is a networked domain or an "autonomous system" which hides the inside networking structure to the outside. Every building is actually connected to the grid so even in case of faults or networking failure the building can continue functioning without any interruption. The central microgrid server and the agents in all the buildings can interactively work with cloud computing services for storage and application without introducing significant initial construction and maintenance costs.

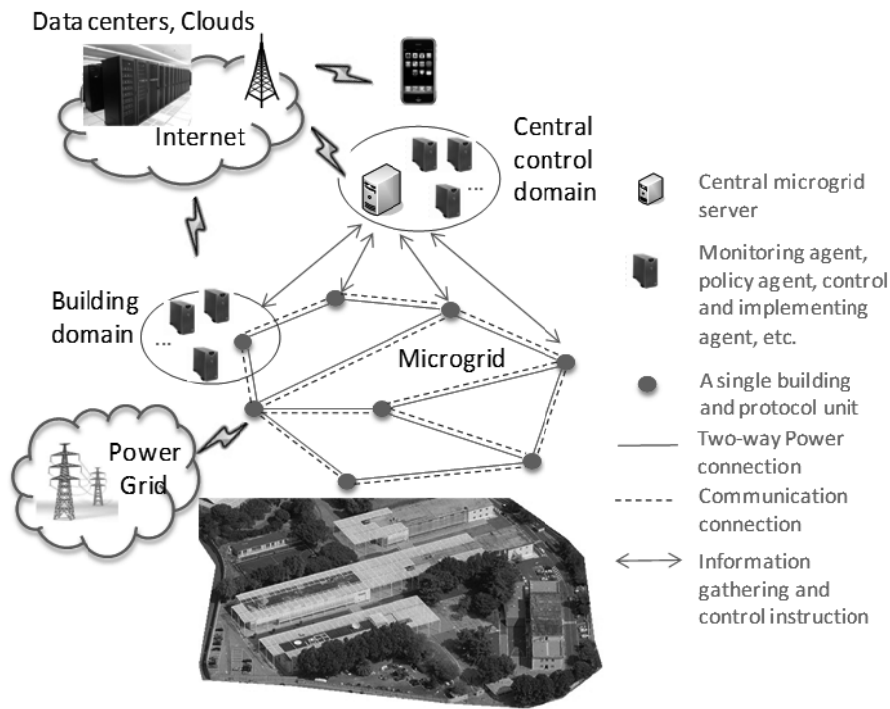

Figure 6.20. A simple illustration of the multiple building microgrid networking and control structure.

On top of the networking topology and protocol problems, the energy efficiency optimization problem can be formalized and modeled as a computing optimization problem. Given all the

constraints, we can use *linear programming* to solve such optimization problems *in polynomial time*.

6.6.9 Lesson #9: Synthesizing three dimensions related to the building concepts for future buildings

There are multiple dimensions of features relating to the concept of intelligent buildings depending on the major design goals. The three most important ones are:

- (1) Communication capability and intelligence;
- (2) Energy generation and conservation capability;
- (3) Material, physical design, environment friendliness, and sustainability.

These are shown in Figure 6.21. If a building is designed and equipped with multiple intelligent technologies, then it is good in the first dimension. The general "intelligent building" concept falls in this category. Similarly, "net-zero energy buildings" [128] mostly focus more on the second dimension which is energy generation and conservation capability for the building to provide relatively stricter and more aggressive energy performance on an annual basis. Lastly, "green buildings" focus on the third dimension using more environment friendly materials and designs to support the global sustainability and environment-protection call.

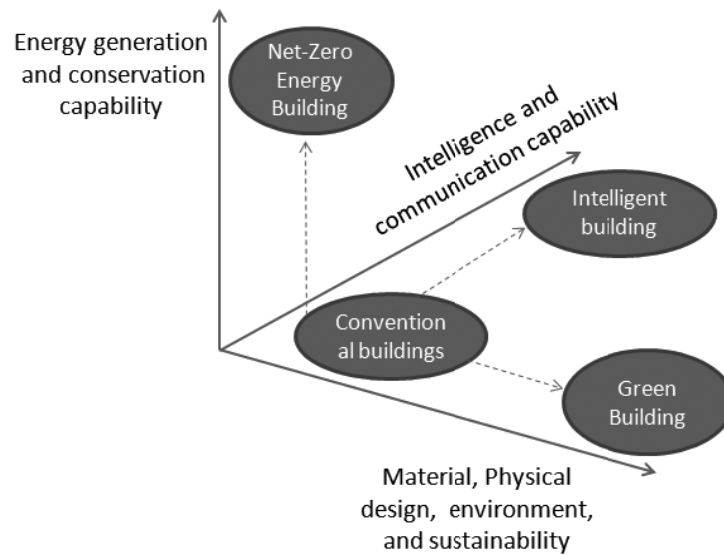

Figure 6.21. Three dimensions of features related to building concept

In our opinion, in terms of global sustainability and energy efficiency, future building designs should do better jobs in all three dimensions. In other words, all three dimensions should be synthesized in a single building, not only by design and construction, but also by the real operation of energy-conservation and generation functional facilities, or the intelligent and networking systems installed and run in the building. For example, an intermediate design combining some of the three individual dimensions mentioned above is called "intelligent or bright and green converged buildings" which integrate features of dimensions (1) and (3).

6.7 Brief Summary

In this chapter, we presented the results and findings of our multi-disciplinary project on building energy efficiency by evaluating and analyzing the energy consumption data we collected in a large office green building testbed. The results showed that the energy consumption in the building is not proportional to both environmental factors and the actual usage and occupancy. The detailed analysis revealed multiple reasons including centralized control and fixed running policies in the buildings. Combined with the concepts we borrowed from the computer industry, we developed a concept of future energy-proportional buildings in which the energy consumption is proportional to the actual usage and occupancy. In a combined networking and energy efficiency perspective, we also summarize the major 9 lessons we learned from the testbed and discussed what they mean for the future intelligent building designs and operation.

Chapter 7

Multi-scale Energy Proportionality Using Location-based Networked Control

Continuing the work in Chapter 6 and based on the findings, in this chapter, we propose a method to enable multi-scale energy proportionality based on smart location-based automated energy control across multiple buildings. It essentially enables a perspective of multi-scale energy proportionality. We further build a prototype system for the location-based idea and present the experimental results, which prove the effectiveness of the proposed idea. The content of this chapter is based on two of our publications [16, 17].

7.1 Introduction

As discussed in the introduction of Chapter 6, buildings are significant energy consumption sources and many factors lead to lower energy efficiency in them, and we have summarized the research on the topics into three major sequential steps:

(1) Energy monitoring. The consumption and generation of energy are monitored and logged in different granularities including the whole building, floors, departments, labs, rooms, and even occupants.

(2) Energy modeling and evaluation. Through off-line modeling and evaluation, find the energy consumption patterns and factors that may influence the consumption and the extent of their impact.

(3) Practical changes and strategy adjustments. The modeling and evaluation results are used to find the key energy components of the building, to apply adjustments, and to devise strategies to reduce energy consumption.

We covered the first two steps in Chapter 6. The results show that due to centralized and fixed pattern control, the actual running of the green building is not energy efficient even though it is "green" by design. Inspired by "energy proportional computing" in modern computers, in this chapter, we propose a smart location-based automated energy control framework using smart phone platform and cloud computing technologies to enable multi-scale energy proportionality, which includes *building, user, and organizational level energy proportionality*. We further build an experimental prototype system to demonstrate the effectiveness of the proposed idea. The results show the potential benefits of the idea in terms of both economic benefits and social sustainability benefits.

Unlike simulation based solution, our work is based on real measured data for a currently in-use on-campus green building, and a real system to control the energy automation. We use the latest information technologies such as mobile smart phone with location service, distributed control, and cloud computing to actively involve the occupants in the energy-saving process. Energy-saving policies from multiple sources such as individuals and organizations are considered in an integrated policy framework in deciding the final energy saving strategies. We aim to create an energy-efficiency testbed that can be easily migrated to all kinds of buildings and achieve energy savings in multiple scales.

In this chapter, firstly, we summarize and refine our previous work in the conference papers [15, 16]. We basically proposed a smart location based networked energy control framework to tackle the issue and improve the energy efficiency. Above that, we add new contributions to complete the three steps described above. Particularly,

- (1) We synthesize the previous separate contributions into a complete framework. It includes the research and work in the whole process of identifying the key problems, finding methods to solve the problem, and developing prototype system to prove the effectiveness of the proposed method.
- (2) We build a novel experimental prototype system which demonstrates the real time location-based automated energy policy control across multiple buildings. It is the basic step to change from the

current centralized control and fixed pattern energy consumption modes to distributed and dynamic energy control in common buildings.

(3) Based on these, we propose to create a future of multi-scale energy proportionality. The central idea is to generalize the smart phone and location-based energy control idea and involve multiple level organizations' policies control. It aggregates the energy saving of individual users and allows distributed and dynamic energy control, which is the key for energy proportionality.

7.2 Smart Location-Based Automated Energy Control Framework

In this section, we present the details of our idea.

7.2.1 Overall Structure

There are multiple design components and aspects which interact with each other and form a complete framework of our idea to fulfill the goals. We envision an occupant oriented and involved networked system and depict it in Figure 7.1.

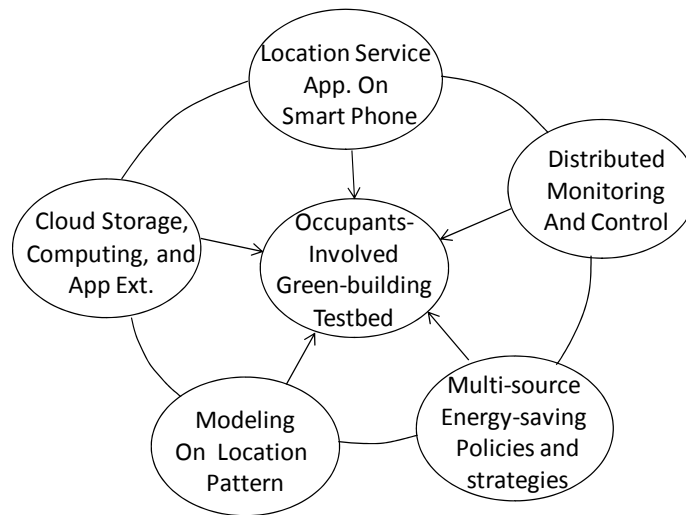

Figure 7.1. Overall structure of our design with components and their interaction

The key design components include: mobile devices based distributed energy monitoring and remote control, location application on smart phone, multi-source energy-saving policies and

strategies, cloud computing platform based data storage and application, and energy data modeling and strategy formation. We discuss these below.

7.2.2 Energy Monitoring

To achieve the goal, it is needed to monitor the energy consumption not only for the whole building, but also in multiple granularities like departments, floors, labs, rooms and individuals. This requires installing monitoring devices into different levels of the building-side grid containing breaker and panels. We currently use both the centrally located high-end commercial metering devices and the low-end panel and power strip level metering devices.

We envision developing a future “Smart Everything” living building environment in which all the electric devices are smart and are able to not only record energy data and upload them automatically through IP network, but also enforce the control and energy-saving policy in real-time and support remote configuration. However, currently there is no one company or research organization that can provide all the products for different sensing and monitoring purposes. One underlying reason may be that this is still an emerging research area, and there are not enough hardware and software available. The standardization process and the broad acceptance of such devices in industry are also not as mature as those for Internet devices such as routers and switches.

Thus, we divide our research efforts into two basic categories. First, we try to integrate the energy sensing and monitoring with networking capability to create an automated data collection, storage, and display system. Our idea is to create a “Smart Box” as an extended box for different sensors and meters without data storage and networking capability. By doing this, we create a common protocol for different sensing and monitoring devices and let them work in a uniform and automated way. We are designing a preliminary suite of protocols and interfaces for interconnecting multiple smart boxes and providing the extensible Application Programming Interface (API) for further functional extension. The results of our work may possibly contribute to the IETF community by interacting with the IETF EMAN (Energy Management) working group. Of course, compatibility will be a big issue when creating such smart box, and we are starting from some common devices and extend the compatible list gradually.

Second, the energy-saving policy will be applied with automation. We need the operation plane (panel, breaker, power strips, etc.) to be also smart to control the on/off status of the circuits and

appliances. These devices are with IP-based capability so that they can be configured and notified in real-time to accomplish the designated strategies and policies.

As shown in Figure 7.2, existing panels are extended by external smart boxes with monitoring, networking, and control modules; existing sensors are extended by integrating external monitoring, networking and control modules; new smart panels aware of our new technologies come with monitoring, networking, and controlling modules; new smart appliances and loads come with the sensing modules for multiple sensing functionalities.

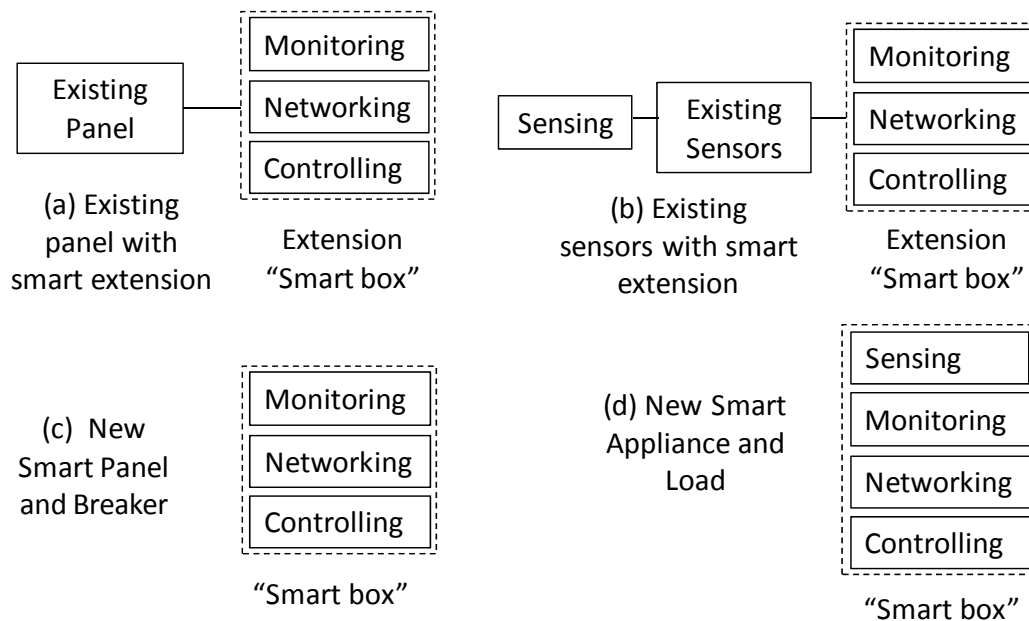

Figure 7.2. Integration of existing devices through “smart box” extension

Obviously it will take some time to achieve the above vision. However, we start the first step of the experiment and we believe this is an important step towards achieving the goals.

7.2.3 Smart Mobile Devices as Remote Controls

In the last several years, smart mobile devices have become very popular. Smart phones generally have multiple networking interfaces such as 3G, WiFi, WiMAX, Bluetooth, and have multiple sensors including GPS (Global Positioning System) sensor. Because of various connectivity provisions and global accessibility to the Internet, they are suitable for use in any system that needs humans’ online participation or interaction. The “Internet of Things” [98] trend makes the cost even lower and the sensors are connected to the Internet at all time.

Smart phones are ideal for monitoring, controlling, and managing the energy control systems remotely from anywhere at any time. After appropriate authentication and authorization, the occupants are permitted to modify and change their energy-saving policies online by interacting with the policy servers of their office and residential buildings. Such design allows dynamic changes to the energy-saving policies and offers better flexibility to the occupants. It can be a good complement to the general policy decision process based on the modeling results. Such an “app” can be easily developed for the smart phone based on the web technology.

7.2.4 Multi-source Energy-saving Policies Hierarchy

In a real environment, various parts of an organization, such as campus, building, department, and labs may be in charge of different components of a building. Each of these may have their own policies and requirements that need to be taken care of in controlling the energy consumption. Even in a single home building, locations of multiple family members and their preferences need to be taken into account. Therefore, in our location based automatic control scheme, we add policies coming from these levels of control hierarchy.

Figure 7.3 shows an example of the policy hierarchy. As shown, there may be a tree-like structure for the building control plane in which there are policy servers enforcing the energy-saving policies covering different levels. This also applies to the residential buildings in which the tree structure may be relatively simple. The mobile users can be connected into the Internet through smart phone, tablet, or even laptop with WiFi connections. In the example shown in Figure 7.3, the mobile smart phone holder leaves the home building and travels towards his office building. The movement and location changes will trigger the policy servers to adjust the energy-saving policies for both buildings accordingly. The action steps are denoted as “①②③” in the figure.

In our previous research on next generation Internet [5, 37] as well as the policy-oriented Internet architecture [78], we have experimented with several policy based control schemes. We apply similar ideas to the building and community environments. In particular, each control region can be defined as a “realm” [37] which is managed by a realm manager (also a policy server in our building testbed). Energy control policies may span multiple realms and sometime conflicts may have to be resolved.

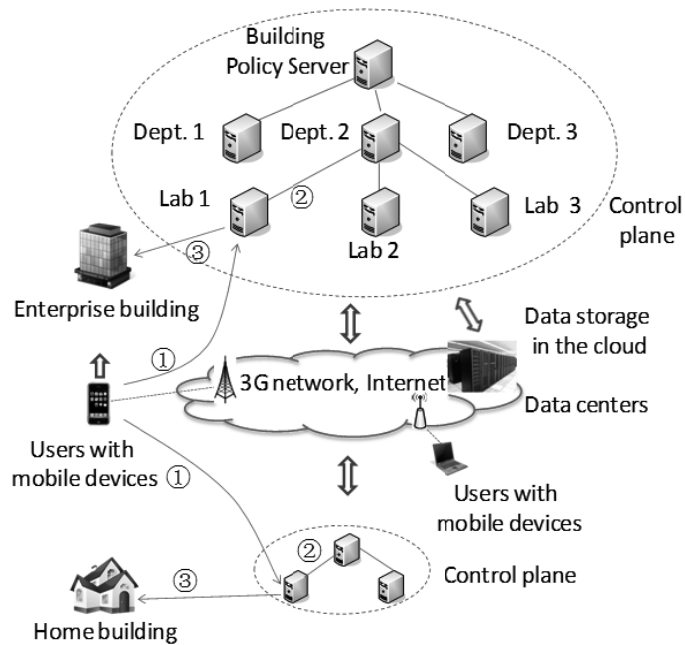

Figure 7.3. Example dynamic multi-source energy-saving policy adjustment by the mobile devices

7.2.5 Mobile Device Location-Based Automatic Control

Almost all phones can determine their location by referring to signal strengths from various transmission towers. Newer smart phones can do so much more precisely with the embedded GPS. We use this location information in designing automatic control policies that can turn on/turn off energy consuming devices at home or office depending upon the location and direction of movement of the user. By doing so, a dynamic and flexible policy can be applied which satisfies the user's preferences for energy saving and comfort. An "App" on the device can automatically enforce these desired policies.

With the help of the location-aware mobile devices, these dynamic adjustment policies could also enable the cooperation and interaction among different buildings. For example, when the location detection daemon on the user's smart phone detects that the user has moved out of a threshold distance range from his home building and is moving into a threshold distance range of his office building, then a message is sent to a centralized server to trigger the policy control process. The office building room owned by the user will start pre-heating/cooling to prepare a user-customized or optimized working environment, while the message also triggers the home building to transit into an energy-saving mode.

7.2.6 Cloud Computing and Storage

Cloud computing has become very promising in the last few years. We have two basic kinds of jobs which need the cloud-computing platform: (1) The cloud-based data storage, and (2) the cloud-based modeling and analysis computation. We have a preliminary design of how to integrate the system into the cloud computing platform, as shown in Figure 7.4.

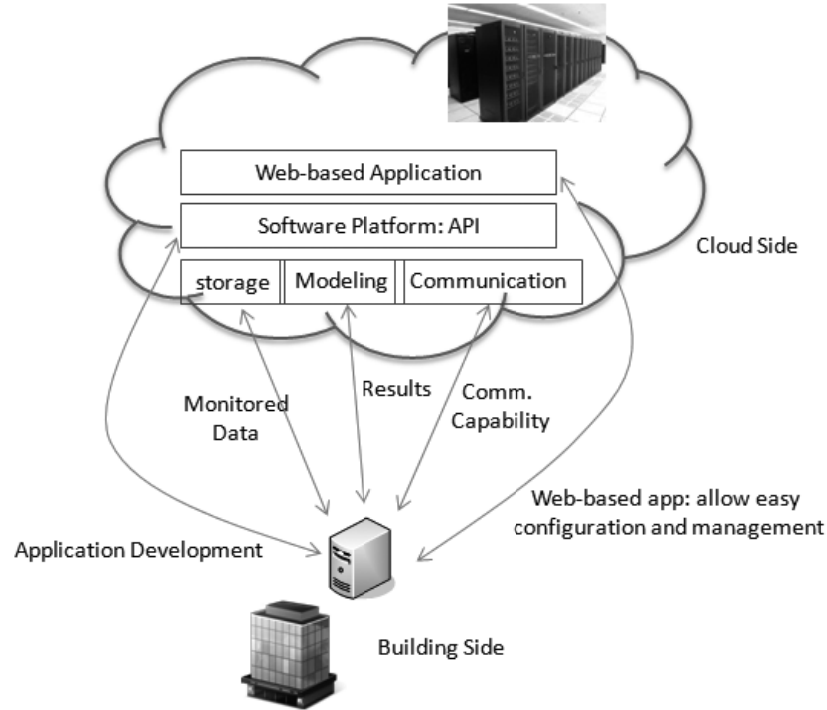

Figure 7.4. Cloud computing components and interaction with the building side servers

In the figure, the cloud provides the basic data storage and retrieval service for the logged building energy consumption data. Computation-intensive modeling and analysis jobs are mostly done in the cloud. The communication layer provides configurability, reliability, and security for the network communication between the cloud and the client. The middle layer in Figure 7.4 is for cloud application development by using the open API provided by the cloud providers such as Google App Engine. The reason we incorporate this layer in our design is that it can alleviate the overhead to develop the cloud application and accelerate our application development and deployment process. It also becomes much easier to integrate other services using the same platform (such as authentication services, email services and user interfaces) to the application on demand and make the development of a cloud application a less complicated task. The top layer is the application layer.

We are researching and developing a user-friendly prototype web-based user interface and application for the building environment, which can be easily configured and managed by the remote client.

7.3 Prototype System, Experimental Results, and Multi-scale Energy Proportionality

This section focuses on the prototype system we build to prove the effectiveness of the idea proposed in Section 6.2.

7.3.1 Prototype Description

In this prototype system, we implemented a simple scenario involving a user associated to two groups of electrical appliances: those in his/her home apartment and those in his/her office room. It is shown in Figure 7.5. It is a simplified scenario of what is shown in Figure 7.3.

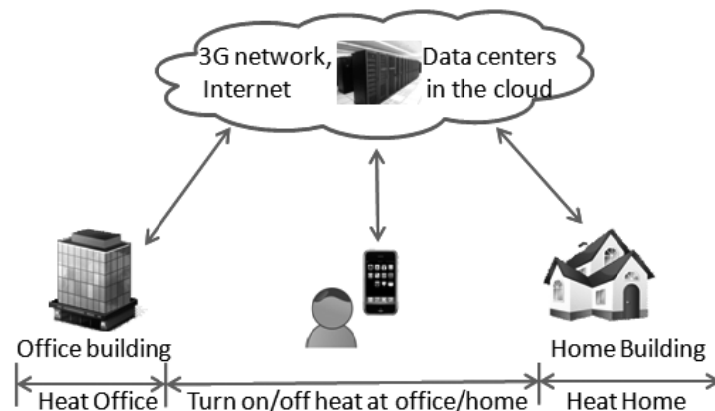

Figure 7.5. A simple example scenario of location-based automated control

Our goal is to allow the user to be able to dynamically adjust and control his/her devices across two buildings. The basic function we try to realize is to enable the server to detect the user's location changes and trigger the energy policy changes by turning on/off the electrical appliances in both buildings associated to the user. By doing this, we essentially enable users to control and implement their own energy policies in real time, and enable their energy consumption to be proportional to their actual usage.

(1) Hardware and networking structure

In the prototype system, the hardware that we use include the "Kill-A-WattTM" electrical meters [129], WeMoTM control devices [130], servers in each building which act as both web daemon server and in-building controller, WiFi routers, and smart devices with location sensors (GPS module).

The networking structure of the prototype system of the home building side is shown in Figure 7.6. The basic function is that the smart mobile device with location sensor keeps sending its location data back to the web servers inside the home building and the office building. The web daemon servers behind the firewall and NAT (Network Address Translation) are accessed from outside by port mapping technology. It also calculates the distance between it and the mobile devices to decide if the distance passes a specific threshold to trigger energy policy changes in either of the buildings. If it does, then it initiates the controller to send instructions to turn on/off specific devices in its territory according to the energy policies.

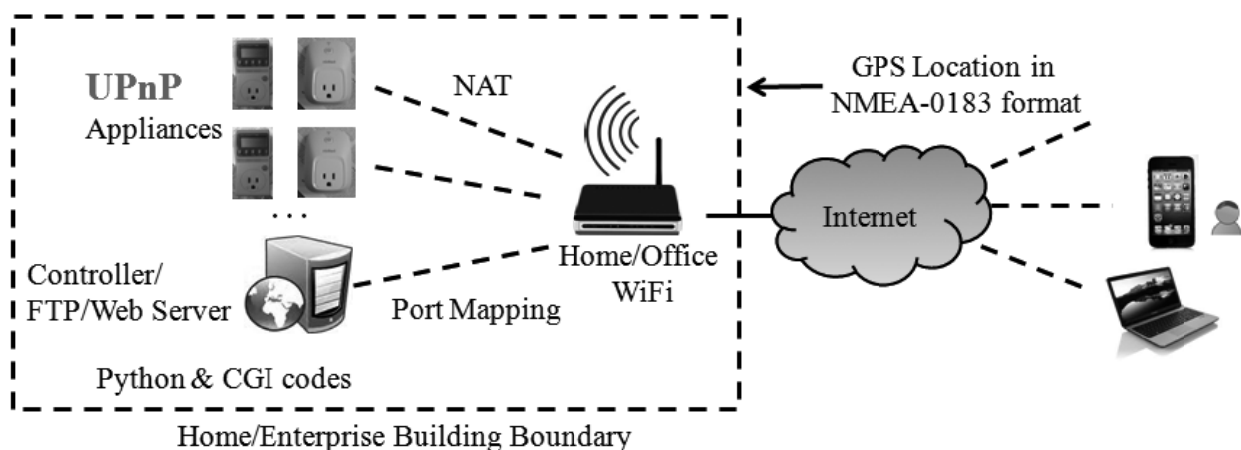

Figure 7.6. Prototype system networking structure

(2) Software

The software part includes the software for GPS location data recording and sending to the web server in NMEA (National Marine Electronics Association)-0183 compliant format, and the WiFi router's configuration and management software which provides port mapping service for web access from outside of the NAT. The web server is programmed with CGI (Common Gateway Interface) scripts to execute Python codes controlling the WeMo devices through UPnP (Universal Plug and Play) protocol. Besides the location based automated control, these software parts working together with the hardware also enable the devices in both buildings to be controllable from Internet in real time through smart devices.

7.3.2 Experiments and Results

We first measure the baseline electricity appliances' power associated with the user in both buildings. The major appliances in the home building of the prototype system and their baseline power measurement and estimation are shown in Table 7.1. Note that in this prototype system we primarily focus on electricity appliances, though in the real case, HVAC can be a significant energy consuming source worth applying dynamic control to make a difference in improving energy efficiency. Similarly, the appliances in office room and its baseline power measurements are shown in Table 7.2.

Table 7.1. Home electricity appliances' baseline power measurements

Type	Lighting		Refrigerator (GE)	Microwave Stove(Philips)	Laptop (Mac Pro 15")	HVAC
Items	Porch:	54W	Start: 200W, gradually to 170W	1.3kW	Normal: 41W Active or charging: 60W	N/A
	Bedroom:	18*2 = 36W				
	Living Room:	54*2+42 = 150W	Compressor work for 9 min, stop for 9 min			
	Kitchen:	52*5 = 260W				
	Bathroom:	54W				
Avg. Power		550W	185/2 W	1.3kW	50W	

Table 7.2. Office room electricity appliances' baseline power measurements

Type	Lighting	Desktop	Laptop (Mac Pro 15")	HVAC
Items	32W * 6 = 192W	Host: Boot – 110W Normal – 67W	Normal: 41W Active or charging: 60W	N/A
		Monitor: Normal – 72W, Active – 80~ 90W		
Avg. Power	192W	160W	50W	

To compare and find the real saving of our prototype system, we divide the users' energy usage into three potential modes: *luxury mode*, *moderate mode*, and frugal *mode*. For each mode, we estimate how much energy will be consumed in a daily basis. The estimation results for home and office are shown in Table 7.3 and Table 7.4 respectively, which also explain the three modes.

Then we apply the location based idea and dynamically control the appliances in both home and office to reduce the energy waste and maximize the energy efficiency. We track and record the location of the user in 24 hours' period and apply dynamic control and policy changes in both home and office. The location history shown in Google map is in Figure 7.7.

Table 7.3. Daily home electricity consumption estimation of three modes

	Lighting	Refrig.	Microwave	Laptop	HVAC		
Luxury Mode (user is energy insensitive)	Always ON except sleeping	Constantly, 185w/2*24 = 2.22 kWh	Constantly, 1.3kw*0.05= 0.065 kWh	Always ON at home	N/A		
	$550w*24*2/3=8.8kWh$			$50w*24*2/3=0.8kWh$			
Moderate Mode	Only ON when at home awake			Constantly, 185w/2*24 = 2.22 kWh		Constantly, 1.3kw*0.05= 0.065 kWh	Only ON when at home awake
	$550w*24*1/3= 4.4 kWh$						$50w*24*1/3= 0.4 kWh$
Frugal Mode (user is energy sensitive)	Only 60% ON when at home awake			Constantly, 185w/2*24 = 2.22 kWh		Constantly, 1.3kw*0.05= 0.065 kWh	Only 60% ON when at home awake
	$4.4 *0.6 =2.64kWh$						$0.4*0.6 = 0.24kWh$
Total	L: 11.90kWh ;	M: 7.09kWh;	F: 5.17kWh				

It shows that the user approximately spent 14 hours at home in which 8 hours for sleep, 2 hours for lunch and rest, and 4 hours for working at home. The total recorded real energy consumption at home during this period is 5.285 kWh, which includes 2.7kWh for lighting, 2.22kWh for refrigerator, 0.065kWh for microwave stove, 0.3kWh for laptop. Also, during this period, the appliances in office room are kept in "OFF" status by the control server of the prototype system. Location history also shows that about 6 hours are spent in office and almost half of the time the desktop is used and for the other half time the laptop is used. The real total energy consumption at office is 2.26kWh, which includes 1.15kWh for lighting, 0.96kWh for desktop, and 0.15kWh for laptop. For the remaining 4

hours, the user is not at home/office, and all the devices are in "OFF" status, except the refrigerator at home.

Table 7.4. Daily office electricity consumption estimation of three modes

	Lighting	Desktop	Laptop	HVAC
Luxury Mode (user is energy insensitive)	Always ON when at office 192W*8= 1.54kWh	Always ON 24/7	Always ON when at office	N/A
		160W*24 =3.84kWh	50W*24*1/3= 0.4kWh	
Moderate Mode		Only ON when at office	Only 50% ON when at office	
	160W*24*1/3 =1.28kWh	0.4*0.5= 0.2 kWh		
Frugal Mode (user is energy sensitive)	Only 60% ON when at office	OFF when at office, use desktop		
	1.28*0.6=0.77kWh	0kWh		
Total	L: 5.78kWh ;	M: 3.02kWh;	F: 2.31kWh	

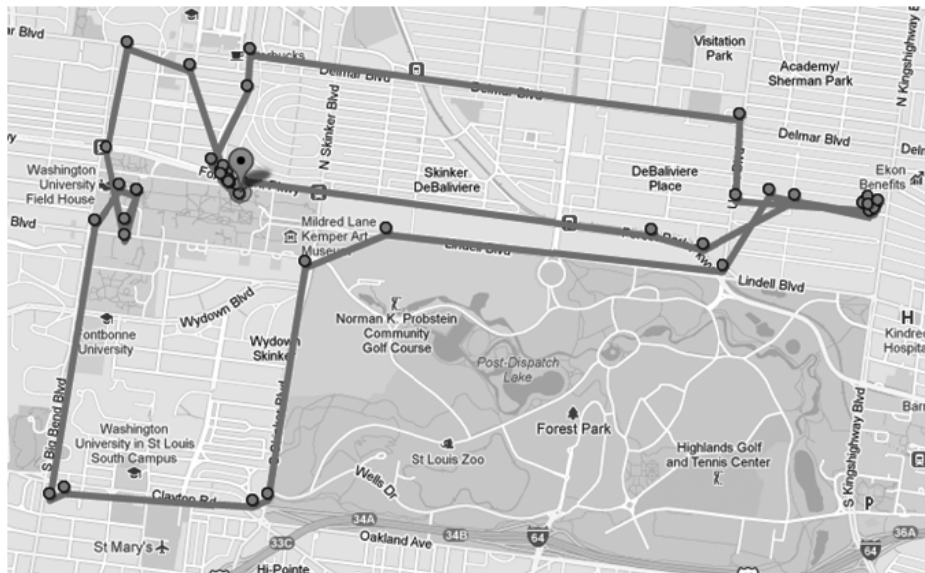

Figure 7.7. Location history in a 24 hours' period

Thus, for comparison, we put the real recorded energy consumption data after applying our idea together with the energy consumption estimation results of the three modes, to demonstrate how much energy can be saved. The results are shown in Figure 7.8. The simple takeaway message is that the real energy consumption of the prototype system after applying our location based idea is *very close to the frugal mode's energy consumption*. It means that with our new idea, the general users can still enjoy luxury living style without special care or changes, but they only need to pay the costs like living in a frugal mode.

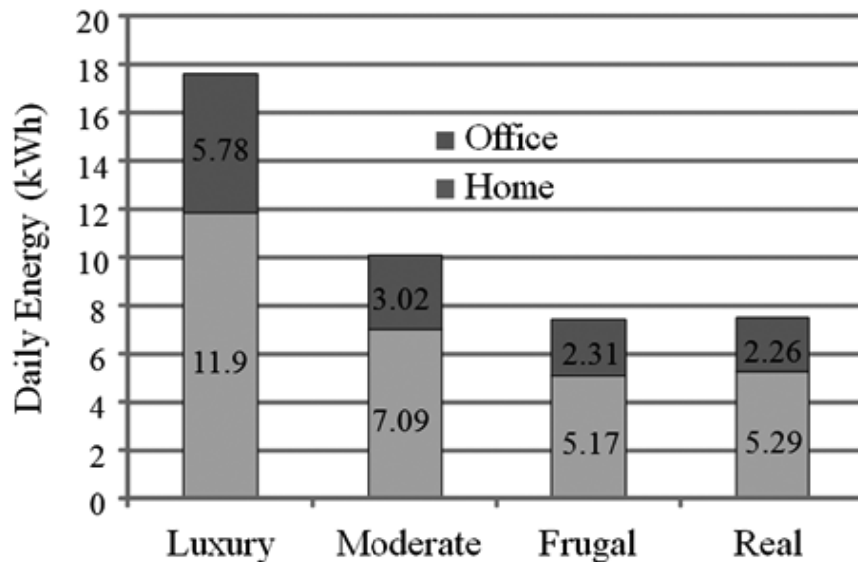

Figure 7.8. Comparison of the real energy consumption after applying our idea with the three modes' energy estimation

7.3.3 Multi-scale Energy Proportionality

To summarize the experiments and results, we can see that the effect of energy saving is conspicuous, although given different types of buildings and occupants' energy using habits, there can be different degrees of saving.

The above prototype system experiments vividly illustrate how *user-scale energy proportionality* is realized by using networking and computing technologies, since the user's energy consumption becomes approximately proportional to his/her actual usage. Besides user-level energy proportionality, applying similar idea into multi-scale organizations in a building, as described in Section 6.3, it virtually enables both *organization-level energy proportionality and building-*

level energy proportionality. Specifically, when a particular user controls and adjusts the appliance policies under his/her territory, he/she has to follow a specialized group policies enforced by the organization such as a laboratory or a department. The organization also enforces the policies for publicly shared parts such as HVAC, lighting, fire and safety, and elevator systems. It could designate special working staff to control and apply energy proportionality for these subsystems. The laboratory or department *aggregates* each user' energy proportionality and the publicly shared subsystems' energy proportionality, to achieve an organization scale energy proportionality. Similarly, the idea can be generalized to building level since it basically aggregates multiple organizations inside the building and multiple public subsystems working for all the organizations in the building.

Achieving multi-scale energy proportionality has profound economic impacts to the society in terms of avoiding huge energy waste and saving costs for users and organizations. The benefits would make a huge difference if the idea gets broadly implemented and deployed. The networking and computing technologies used for the system enable the building running and operation to be more intelligent and efficient, and in an automated manner without manual intervention. All the stakeholders including the common occupants and users, organizations' authorities, and buildings' owners and tenants could have total flexible control over their own energy policies, which is a very promising feature for our proposed idea. Moreover, the proposed system also involves every user and organization to participate in the energy saving efforts, which is potentially a very good training and education method to encourage everyone to study and participate in resolving global climate and sustainability issues in everyday life. Further incorporation of social network plugin into the smart mobile phone based energy control platform would generate even broader impacts [16].

7.4 Brief Summary

In this chapter, we summarized our work regarding green building energy consumption data analysis and new design applying networking and computing technologies to improve the energy efficiency. We put them into a complete three-step research framework and added new contribution of creating a prototype system and doing related experiments proving the ideas and concepts we proposed. By finishing a complete three-step research and experiments, we aim to enable multi-scale energy proportionality. We envision that the idea will provide not only significant economic benefits but also huge social benefits in terms of global sustainability.

Chapter 8

Summary

During the last decade, Internet has come into almost every industry and changed our everyday living. The major usage of Internet has changed dramatically and the original designs are facing significant challenges. So the first focus of this dissertation is on the research of a new Internet architecture that address multiple challenges such as routing scalability, mobility, multihoming, renumbering, traffic engineering, and policy enforcements. Our framework design incorporates a series of new design principles which mimic the biological evolutionary principles.

On the other hand, interdisciplinary research opportunities arise among multiple areas such as networking, energy, and smart grids. Particularly, we focus on researching potential methods of applying Internet and networking technologies to the intelligent buildings, which is also the consumer-side part of the smart grids, for smart automation and energy efficiency optimization.

Hence, our primary research was focused on two correlated parts: Part I, next generation Internet architecture and key research issues; and Part II, cyber-assisted energy efficiency, smart grid, and sustainability. For the PART I, we designed the future Internet architecture to be evolvable, scalable, providing mobility support, etc. For PART II, however, we envisioned the future Smart Grids to incorporate more Internet and networking technologies to make its infrastructure smarter, more energy efficient, and use more renewable energy sources for global sustainability. In this dissertation, we covered the major contributions for both these two parts.

For PART I, first, we introduced the basic framework of the new Internet architecture we proposed, which we named as MILSA. It uses the ID Locator Split concept and is a holistic and evolutionary architecture based on administrative realm-based organizational control and new naming and addressing schemes, attacking the major deficiency of the current Internet. It essentially

differentiates two types of dependency relationships: administrative dependency and functional dependency. It incorporates a series of new design principles mimicking the principles of the biological evolution, and is expected to be deployable in the existing Internet gradually.

After that, we further presented several design enhancements to the naming and mapping mechanism in the framework. Particularly, we illustrated the details on how the ID Locator Split works in the protocol stack, how the IDs in various tiers are designed, and how the ID space in different tiers can be mapped into lower tier IDs through dynamical bindings and mappings.

In addition, we discussed the hybrid transition mechanisms. We designed the mechanisms to enable our architecture to accommodate both of the two competing directions of ID locator split on the host side and "core edge separation". We took advantage of the common mapping system and designed it to work in a compatible way. Such enhancements provide combined features and flexible deployment.

To support data and user level multihoming, we presented and discussed a multihoming framework built upon host multihoming infrastructure, given the trend that contents and users are supposed to have more important roles in the future Internet architecture. It is designed to support step-by-step deployment with incremental features and costs.

Second, we focused on the evaluation of the inter-domain routing system based on real routing table data for routing scalability and a series of other related issues. By defining a series of novel quantitative metrics and carrying out systematic evaluation with these metrics, we try to find useful information for the future Internet architecture design and deployment considering various incentives and strategies. Hence, the major evaluation work includes not only the evaluation to know the current status of the inter-domain routing system but also the evaluation related to new Internet architecture deployment.

For PART II, first, we did a comprehensive review of the key research topics and issues in intelligent buildings with a perspective combining energy efficiency and networking technologies. After that, we did the energy consumption data collection, modeling, and evaluation for a green building testbed. We found the major reasons underlying the inefficiency of the typical conventional buildings. Specifically, we found that the real energy consumption of the building is not proportional to the actual usage of weather conditions due to the reasons such as centralized control and fixed running pattern. Based on that, we proposed the concept of "energy proportionality" in buildings

similar to the energy proportionality in computers. The benefits of the energy proportional buildings prospect include energy efficiency and savings, users' comfort and productivity, and global sustainability.

After that, we proposed a method using smart location-based automated energy control to enable multi-scale energy proportionality for both individual building as well as across multiple buildings. It changes the centralized and fixed pattern energy control into distributed and dynamic pattern energy control, and allows not only building level energy proportionality but also energy proportionality for any group scale, for example, a single user or a specific organization. We further built a prototype system for the location-based idea and presented the experimental results, which proved the effectiveness of the proposed idea.

References

- [1] D. Meyer, L. Zhang, K. Fall, "Report from IAB workshop on routing and addressing," RFC 4984, September, 2007.
- [2] Software Defined Networking (SDN), http://en.wikipedia.org/wiki/Software-defined_networking
- [3] S. Paul, J. Pan, R. Jain, "Architectures for the Future Networks and the Next Generation Internet: A Survey," Computer Communications, UK, Volume 34, Issue 1, 15 January 2011, Pages 2-42.
- [4] J. Pan, R. Jain, S. Paul, "A Survey of Research on Future Internet Architectures," IEEE Communications Magazine, Vol. 49, No. 7, July 2011, pp. 26-36.
- [5] J. Pan, S. Paul, R. Jain, Mic Bowman, "MILSA: A Mobility and Multihoming Supporting Identifier Locator Split Architecture for Naming in the Next Generation Internet," in the Proceedings of IEEE Global Communications Conference (GLOBECOM) 2008, New Orleans, LA, USA, 30 November - 4 December 2008.
- [6] J. Pan, R. Jain, S. Paul, M. Bowman, X. Xu, S. Chen, "Enhanced MILSA Architecture for Naming, Addressing, Routing and Security Issues in the Next Generation Internet," in the Proceedings of IEEE International Conference on Communications (ICC) 2009, Dresden, Germany, 14 June - 18 June 2009.
- [7] J. Pan, S. Paul, R. Jain, "Hybrid Transition Mechanism for MILSA Architecture for the Next Generation Internet," in IEEE Globecom Workshop on Future Internet (FutureNet II) 2009, Honolulu, Hawaii, 30 November - 4 December 2009.
- [8] J. Pan, R. Jain, S. Paul, and C. So-In, "MILSA: A New Evolutionary Architecture for Scalability, Mobility, and Multihoming in the Future Internet," IEEE Journal on Selected Areas in Communications (JSAC), Special issue on Routing Scalability, Vol. 28, Issue 8, pp 1344-1362, October 2010.

- [9] J. Pan, R. Jain, and S. Paul, "Enhanced Evaluation of the Inter-domain Routing System for Balanced Routing Scalability and New Internet Architecture Deployment," IEEE Systems Journal, September, 2013..
- [10] J. Pan, R. Jain, and S. Paul, "A Novel Incremental-Deployable Multi-granularity Multihoming Framework for the Future Internet," in the Proceedings of IEEE Global Communications Conference (GLOBECOM) 2012, Anaheim, CA, December 3-7, 2012.
- [11] T. Li, "Design Goals for Scalable Internet Routing," IRTF RFC 6227, May 2011.
- [12] USGBC Research Committee, "A National Green Building Research Agenda," November, 2007.
- [13] M. R. Finley Jr., A. Karakura, and R. Nbogni, "Survey of intelligent building concepts," IEEE Communication Magazine, April 1991.
- [14] J. Pan, R. Jain, S. Paul, "A Survey of Energy Efficiency in Buildings and Microgrids using Networking Technologies," accepted by IEEE Communications Surveys and Tutorials, Special issue on Energy and Smart Grid, 2014.
- [15] J. Pan, R. Jain, S. Paul, P. Biswas, et al., "Toward an Energy-Proportional Building Prospect: Evaluation and Analysis of the Energy Consumption in a Green Building Testbed," in the Proceedings of IEEE Energytech 2013, Cleveland, OH, May 21-23, 2013.
- [16] J. Pan, R. Jain, P. Biswas, et al., "A Framework for Smart Location-Based Automated Energy Controls in a Green Building Testbed," in the Proceedings of IEEE EnergyTech 2012, Cleveland, OH, May 29-31, 2012.
- [17] J. Pan, R. Jain, S. Paul, "Energy Efficiency Evaluation and Network Architecture Design and Prototyping for the Consumer-side Smart Grids of Buildings," submitted to IEEE Journal on Selected Areas in Communications (JSAC), Special issue on Smart Grid Communications, 2013.
- [18] NSF Future Internet Architecture Project. [Online Webpage]. <http://www.nets-fia.net/>
- [19] NSF NeTS FIND Initiative. [Online Webpage]. <http://www.nets-find.net>
- [20] Named Data Networking Project. [Online Webpage]. <http://www.named-data.net>
- [21] MobilityFirst Future Internet Architecture Project. [Online Webpage]. <http://mobilityfirst.winlab.rutgers.edu/>

- [22] NEBULA Project. [Online Webpage]. <http://nebula.cis.upenn.edu>
- [23] eXpressive Internet Architecture Project. [Online Webpage]. <http://www.cs.cmu.edu/~xia/>
- [24] Global Environment for Network Innovations (GENI) Project. [Online Webpage]. <http://www.geni.net/>
- [25] OpenFlow Switch Consortium. [Online Webpage]. <http://www.openflowswitch.org/>
- [26] Future Internet Assembly. [Online Webpage]. <http://www.future-internet.eu/home/future-internet-assembly.html>
- [27] FIRE: Future Internet Research and Experimentation. [Online Webpage]. <http://cordis.europa.eu/fp7/ict/fire/>
- [28] European Future Internet Portal, <http://www.future-internet.eu/>
- [29] The Network of the Future Projects of EU FP7. [Online Webpage] http://cordis.europa.eu/fp7/ict/future-networks/home_en.html
- [30] The FP7 4WARD Project. [Online Webpage]. <http://www.4ward-project.eu/>
- [31] GEANT2 Project. [Online Webpage]. <http://www.geant2.net/>
- [32] AKARI Architecture Design Project. [Online Webpage]. <http://akari-project.nict.go.jp/eng/index2.htm>
- [33] JGN2plus- Advanced Testbed Network for R&D. [Online Webpage]. <http://www.jgn.nict.go.jp/english/index.html>
- [34] China Education and Research Network (CERNET). [Online Webpage]. <http://www.edu.cn/english/>
- [35] CERNET2 Project. [Online Webpage]. http://www.cernet2.edu.cn/index_en.htm
- [36] Internet 3.0 project. [Online Webpage] <http://www1.cse.wustl.edu/~jain/research/index.html>
- [37] R. Jain, "Internet 3.0: Ten Problems with Current Internet Architecture and Solutions for the Next Generation," IEEE MILCOM 2006, Washington, DC, October 23-25, 2006.
- [38] Perkins, C., Ed., "IP Mobility Support for IPv4", RFC 3344, August 2002.

- [39] Johnson, D., Perkins, C., and J. Arkko, “Mobility Support in IPv6”, RFC 3775, June 2004.
- [40] J. Rosenberg, H. Schulzrinne, G. Camarillo, et al., “SIP: Session Initiation Protocol,” RFC 3261, June 2002.
- [41] J. Abley, K. Lindqvist, E. Davies, et al., “IPv4 multihoming practices and limitations,” RFC 4116, July 2005.
- [42] R. Moskowitz, P. Nikander and P. Jokela, “Host Identity Protocol (HIP) Architecture,” RFC4423, May 2006.
- [43] E. Nordmark, M. Bagnulo, “Internet Draft: Shim6: level 3 multihoming Shim protocol for IPv6,” draft-ietf-shim6-proto-09, October, 2007.
- [44] D. Farinacci, V. Fuller, D. Meyer, et al, “Locator/ID Separation Protocol (LISP),” RFC 6830, January, 2013.
- [45] Mike O’Dell, “Internet Draft: GSE - an alternate addressing architecture for IPv6,” draft-ietf-ipngwg-gseaddr-00, February 24, 1997.
- [46] Ion Stoica, Daniel Adkins, et al, “Internet Indirection Infrastructure,” ACM SIGCOMM ’02, Pittsburgh, Pennsylvania, USA, 2002.
- [47] Internet Research Task Force Routing Research Group Wiki page, 2008.
<http://trac.tools.ietf.org/group/irtf/trac/wiki/RoutingResearchGroup>
- [48] T. Li, “Internet Draft: Preliminary Recommendation for a Routing Architecture,” draft-irtf-rrg-recommendation-00, February 2009.
- [49] P. Nikander, et al, “Host Identity Indirection Infrastructure (Hi3),” in the Second Swedish National Computer Networking Workshop 2004 (SNCNW2004), Karlstad, Sweden, Nov. 2004.
- [50] C. Vogt, “Six/one router: a scalable and backwards compatible solution for provider-independent addressing,” In ACM SIGCOMM MobiArch Workshop, Seattle, WA, 2008.
- [51] D. Jen, M. Meisel, D. Massey, L. Wang, B. Zhang, and L. Zhang, “APT: A Practical Tunneling Architecture for Routing Scalability,” Technical Report 080004, UCLA, 2008.
- [52] G. Huston, “Scaling Inter-domain Routing—A View Forward,” Internet Protocol Journal, 4(4):2–16, December, 2001.

- [53] G. Huston, "Analyzing the Internet BGP Routing Table," *The Internet Protocol Journal*, July, 2003.
- [54] P. Francis, X. Xu, H. Ballani, "FIB Suppression with Virtual Aggregation and Default Routes," draft-francis-idr-intra-va-01.txt, September, 2008.
- [55] H. Ballani, P. Francis, T. Cao, and J. Wang, "ViAggre: Making Routers Last Longer!" *Proceedings of Hotnets*, 2008.
- [56] Y. Afek, O. Ben-Shalom, and A. Bremler-Barr, "On the Structure and Application of BGP Policy Atoms," in *ACM SIGCOMM Internet Measurement Workshop*, November, 2002.
- [57] L. Subramanian, M. Caesar, C. Ee, M. Handley, M. Mao, S. Shenker, I. Stoica, "HLP: a next-generation interdomain routing protocol," *ACM SIGCOMM*, August, 2005.
- [58] L. J. Cowen, "Compact routing with minimum stretch," *the 10th Annual ACM-SIAM Symposium on Discrete Algorithms (Jan. 1999)*, pp. 255–260.
- [59] X. Yang, "NIRA: A new Internet routing architecture," *Proceedings of ACM SIGCOMM FDNA 2003 Workshop*, Karlsruhe, Germany, August, 2003.
- [60] I. Castineyra, N. Chiappa, M. Steenstrup, "The Nimrod Routing Architecture," RFC 1992, August, 1996.
- [61] R. Whittle, S. Russert, "TTR Mobility Extensions for Core-Edge Separation Solutions to the Internet's Routing Scaling Problem," August 25, 2008.
- [62] C. de Launois, B. Quoitin, and O. Bonaventure, "Leveraging Network Performances with IPv6 Multihoming and Multiple Provider-Dependent Aggregatable Prefixes," *Elsevier Computer Networks*, volume 50, June, 2006.
- [63] R. Atkinson, S. Bhatti, and S. Hailes, "A Proposal for Unifying Mobility with Multi-Homing, NAT, & Security," in *ACM MobiWac*, Greece, 2007.
- [64] T. Bates, Y. Rekhter, "Scalable Support for Multihomed Multi-provider Connectivity," RFC 2260, January, 1998.
- [65] V. Devarapalli, R. Wakikawa, A. Petrescu, et al., "Network Mobility (NEMO) Basic Support Protocol," RFC 3963, January, 2005.

- [66] L. Gao, "On Inferring Autonomous System Relationships in the Internet," IEEE Globe Internet, November, 2000.
- [67] L. Subramanian, S. Agarwal, J. Rexford, and R. H. Katz, "Characterizing the Internet hierarchy from multiple vantage points," Proceedings of the IEEE Infocom 2002, June, 2002.
- [68] T. Bu, L. Gao, and D. Towsley, "On characterizing BGP routing table growth," In IEEE Global Internet Symposium, November, 2002.
- [69] F. Wang, L. Gao, J. Wang, and J. Qiu, "On understanding of transient interdomain routing failures," Proceedings of ICNP 2005, Boston, MA, November, 2005.
- [70] T. G. Griffin and G. Huston, "BGP Wedgies," RFC 4264, November 2005.
- [71] O. Bonaventure, "Reconsidering the Internet Routing Architecture," Internet Draft draft-bonaventure-irtf-rrg-rira-00.txt, March, 2007.
- [72] N. Feamster, H. Balakrishnan, J. Rexford, A. Shaikh, and J. van der Merwe, "The case for separating routing from routers," Proceedings of ACM SIGCOMM Workshop on Future Directions in Network Architecture, August, 2004.
- [73] T. G. Griffin, A. D. Jaggard, and V. Ramachandran, "Design principles of policy languages for path vector protocols," in Proceedings of ACM SIGCOMM'03. ACM Press, August 2003, pp. 61–72.
- [74] J. Day, Patterns in Network Architecture: A Return to Fundamentals, Prentice Hall, Jan 2008.
- [75] C. Dovrolis, "What would Darwin think about clean-slate architectures?" ACM SIGCOMM Computer Communication Review. January 2008.
- [76] A. Feldmann, "Internet clean-slate design: What and why?" SIGCOMM Computer Communication Review, vol. 37, no. 3, pp. 59-64, July 2007.
- [77] J.H. Saltzer, D.P. Reed, D.D. Clark, "End-to-end arguments in system design," ACM Transactions on Computer Systems (TOCS), Vol.2, Issue 4, pp 277-288, November, 1984.
- [78] S. Paul, R. Jain, J. Pan, Mic Bowman, "A Vision of the Next Generation Internet: A Policy Oriented Perspective," British Computer Society (BCS) International Conference on Visions of Computer Science, Imperial College, London, September 22-24, 2008.

- [79] N. Feamster, L. Gao, and J. Rexford, "How to lease the Internet in your spare time," ACM SIGCOMM Computer Communication Review, pp. 61–64, January, 2007.
- [80] D. Thaler, "Why do we really want a ID/locator split anyway?" presented to MobiArch 2008, Seattle, WA, August, 2008.
- [81] L. Mathy, et al, "LISP-DHT: Towards a DHT to map identifiers onto locators," draft-mathy-lisp-dht-00, February, 2008.
- [82] H. Zhang and M. Chen, "Forming an IPv6-only Core for Today's Internet," Proceedings of ACM SIGCOMM IPv6 Workshop, August, 2007.
- [83] X. Xu, Dayong Guo, "Hierarchical Routing Architecture," Proc. 4th Euro-NGI Conference on Next Generation Internetworks, Krakow, Poland, 28-30 April, 2008.
- [84] A. Durand, R. Droms, B. Haberman, J. Woodyatt, "Dual-stack lite broadband deployments post IPv4 exhaustion," draft-durand-softwire-dual-stack-lite-01, November 2008.
- [85] E. Nordmark, R. Gilligan, "Basic Transition Mechanism for IPv6 Hosts and Routers," RFC 4213, October, 2005.
- [86] V. Fuller, T. Li, "Classless Inter-domain Routing (CIDR): The Internet Address Assignment and Aggregation Plan," RFC 4632, August 2006.
- [87] Y. Rekhter, T. Li, S. Hares, "A Border Gateway Protocol 4 (BGP-4)," RFC 4271, January 2006.
- [88] R. Stewart, "Stream Control Transmission Protocol," RFC 4960, September 2007.
- [89] X. Liu, L. Xiao, "A Survey of Multihoming Technology in Stub Networks: Current Research and Open Issues," IEEE Network, Vol. 21, Issue 3, May-June 2007.
- [90] C. de Launois, B. Quoitin, and O. Bonaventure, "Leveraging Network Performances with IPv6 Multihoming and Multiple Provider-Dependent Aggregatable Prefixes," Elsevier Computer Networks, vol. 50, June 2006.
- [91] R. Atkinson, S. Bhatti, and S. Hailes, "A Proposal for Unifying Mobility with Multi-Homing, NAT, & Security," ACM MobiWac, Greece, 2007.

- [92] T. Bates, Y. Rekhter, "Scalable Support for Multihomed Multi-provider Connectivity," RFC 2260, January 1998.
- [93] T. Koponen, M. Chawla, B.-G. Chun, et al., "A Data-Oriented (and Beyond) Network Architecture," ACM SIGCOMM 2007, Kyoto, Japan, August 2007.
- [94] V. Jacobson, D.K. Smetters, et al., "Networking Named Content," in Proceedings of CoNEXT 2009, Rome, Italy, December 1-4, 2009.
- [95] P. Maniatis, M. Roussopoulos, E. Swierk, et al., "The Mobile People Architecture," ACM Mobile Computing and Communications Review (MC2R), vol. 3, no. 3, July 1999.
- [96] M. Roussopoulos, P. Maniatis, E. Swierk, et al., "Person-Level Routing in the Mobile People Architecture." USENIX Symposium on Internet Technologies and Systems, October 1999.
- [97] S. Paul, R. Jain, J. Pan, "Multi-Tier Diversified Architecture for the Next Generation Internet," Proceedings of International Conference on Cloud Computing and Virtualization (CCV 2010), Singapore, May 17-18, 2010.
- [98] Internet of Things [Online]. Available: http://en.wikipedia.org/wiki/Internet_of_Things
- [99] K. Xu, Z. Duan, Z.-L. Zhang, and J. Chandrashekar, "On Properties of Internet Exchange Points and Their Impact on AS Topology and Relationship," Networking, Springer-Verlag, LNCS, Vol. 3042, pp. 284–295, 2004.
- [100] H. Haddadi, M. Rio, G. Iannaccone, A. Moore, and R. Mortier, "Network topologies: inference, modeling and generation," IEEE Commun. Surveys Tutorials, Vol. 10, No. 2, 2008.
- [101] T. Bates, et al., "The CIDR Report," [Online]. Available: <http://www.cidr-report.org/>
- [102] M. Roughan, W. Willinger, O. Maennel, et al., "10 Lessons from 10 Years of Measuring and Modeling the Internet's Autonomous Systems," IEEE Journal on Selected Areas in Communications, vol. 29, no. 9, Oct. 2011.
- [103] L. Cittadini, W. Mühlbauer, S. Uhlig, et al., "Evolution of Internet Address Space Deaggregation: Myths and Reality," in IEEE Journal on Selected Areas in Communications, Vol. 28, No. 8, October 2010.
- [104] K. Fall, G. Iannaccone, and S. Ratnasamy, "Routing tables: Is smaller really much better?" Proc. of HotNets'09, New York, USA, October 2009.

- [105] CAIDA: The Cooperative Association for Internet Data Analysis [Online]. Available: <http://www.caida.org>
- [106] Oregon Route Views, “University of Oregon Route Views Project,” Eugene, OR. [Online]. Available: <http://www.routeviews.org/>
- [107] X. Dimitropoulos, D. Krioukov, G. Riley, K. Claffy, “Revealing the Autonomous System Taxonomy: The Machine Learning Approach,” Passive and Active Measurements Workshop (PAM), March, 2006.
- [108] X. Dimitropoulos, D. Krioukov, M. Fomenkov, “AS Relationships: Inference and Validation,” ACM SIGCOMM Computer Communication Review, January, 2007.
- [109] B. Zhang, L. Zhang, “Evolution Towards Global Routing Scalability,” draft-zhang-evolution-01.txt, March 3, 2009.
- [110] V. Cerf, B. Davie, A. Greenberg, et al., “FIND Observer Panel Report,” April 9, 2009. [Online]. Available: http://www.nets-find.net/FIND_report_final.pdf/
- [111] A. Feldmann, “Internet clean-slate design: What and why?” SIGCOMM Computer Communication Review, vol. 37, no. 3, pp. 59-64, July 2007.
- [112] C. Dovrolis, “What would Darwin think about clean-slate architectures?” ACM SIGCOMM Computer Communication Review. January 2008.
- [113] C. Labovitz, S. Iekel-Johnson, D. McPherson, et al., “Internet Inter-Domain Traffic,” Proc. of ACM SIGCOMM 2010, India, August 30–September 3, 2010.
- [114] J. Pan, R. Jain, S. Paul, “Nine Lessons Learned from a Green Building Testbed: a Networking and Energy Efficiency Perspective,” in the Proceedings of IEEE World Congress on Sustainable Technologies (WCST-2013), December 9-12, 2013, London, UK.
- [115] USGBC Research Committee, “A National Green Building Research Agenda,” November, 2007.
- [116] Building Energy Software Tools Directory, U.S. Department of Energy, http://apps1.eere.energy.gov/buildings/tools_directory/.
- [117] EnergyPlus Energy Simulation Software, U.S. Department of Energy, <http://apps1.eere.energy.gov/buildings/energyplus/>

- [118] F. Flouquet, "Local weather correlations and bias in building parameter estimates from energy-signature models," *Energy and Buildings*, Volume 19, Issue 2, Pages 113-123, 1992.
- [119] K. Wan, D. Li, J. Lam, "Assessment of climate change impact on building energy use and mitigation measures in subtropical climates," *Energy*, Volume 36, Issue 3, Pages 1404-1414, March, 2011.
- [120] Reference List for Building Energy Modeling, <http://cse.wustl.edu/~jp10/energyref.htm>
- [121] X. Jiang, M. V. Ly, J. Taneja, "Experiences with a High-Fidelity Wireless Building Energy Auditing Network," in the Proceedings of the 7th ACM Conference on Embedded Networked Sensor Systems (SenSys 2009), New York, 2009.
- [122] V. Singhvi, A. Krause, C. Guestrin, "Intelligent Light Control using Sensor Networks," Proc. of the 3rd international conference on Embedded networked sensor systems (SenSys 2005), 2005.
- [123] USGBC Leadership in Energy and Environmental Design (LEED), <http://www.usgbc.org/DisplayPage.aspx?CategoryID=19>
- [124] U. S. Green Building Council, <http://www.usgbc.org/>
- [125] R. Jain, "The Art of Computer Systems Performance Analysis: Techniques for Experimental Design, Measurement, Simulation, and Modeling," Wiley, 1991.
- [126] L.A. Barroso, U. Holzle, "The Case for Energy-Proportional Computing," *IEEE Computer*, Dec. 2007, Vol 40, Issue 12, pp. 33-37.
- [127] R. Lasseter, A. Akil, C. Marnay, et al, "The CERTS (Consortium for Electric Reliability Technology Solutions) White Paper on Integration of Distributed Energy Resources – The CERTS MicroGrid Concept," Lawrence Berkeley National Lab, 2002.
- [128] Net Zero Energy Building Certificate by "Living Building Challenge," <http://living-future.org/netzero/>
- [129] P3 International, Kill-A-Watt product series, <http://www.p3international.com/products/p4400.html>
- [130] Belkin WeMo switch, <http://www.belkin.com/us/wemo/>

- [131] R.H. Lasseter, P. Paigi, "Microgrid: a Conceptual Solution," in Proceedings of 35th IEEE Annual Conferences on Power Electronics Specialists, pp 4285-4290, Vol.6, June 20-25, 2004.
- [132] Microgrid Hub, Galvin Electricity Initiative, 2012, [Online Webpage], <http://www.galvinpower.org/microgrids>
- [133] N. hatziargyriou, H. Asano, R. Iravani, C. Marnay, "Microgrid: An Overview of Ongoing Research, Development, and Demonstration Projects, " IEEE Power and Energy Magazine, July/Autust, 2007.
- [134] C. Marnay, G. Venkataramanan, "Microgrids in the evolving electricity generation and delivery infrastructure," IEEE Power Eng Soc Gen Meet 2006:18–22.
- [135] Pareto Energy, "Briefing on Energy Improvement District Microgrid," Presentation to US Congressional Staff, May 10, 2010.
- [136] F. Sim, "Using Moore's Law to Make Energy Personal," Intel Open Energy Initiative Panel, May, 2010.
- [137] Galvin Electricity Initiative, "Microgrids: a Critical Component of U.S. Energy Policy," May 20, 2010.
- [138] R. H. Lasseter, P. Paigi, "Microgrid: a Conceptual Solution," 35th Annual IEEE Power Electronics Specialists Conference, Aachen, Germany, 2004.
- [139] C. Chen, Y. Wang, J. Lai, Y. Lee, et al, "Design Of Parallel Inverters For Smooth Mode Transfer Microgrid Applications," IEEE Transactions on Power Electronics, 25(1), (2010): 6-15.
- [140] Y. Ito, Z. Yang, and H. Akagi. "DC Microgrid Based Distribution Power Generation System," in the 4th International Conference on Power Electronics and Motion Control (IPEMC 2004), vol. 3, pp. 1740-1745, 2004.
- [141] X. Li, Y. Song, and S. Han, "Study On Power Quality Control In Multiple Renewable Energy Hybrid Microgrid System," in IEEE Power Tech 2007, Lausanne, pp. 2000-2005. IEEE, 2007.
- [142] J. Sumita, K. Nishioka, Y. Noro, H. Shinohara, et al, "A Study Of Isolated Operation Of A Microgrid Configured With New Energy Generators," IEEE Transactions on Power and Energy 127 (2007): 145-153.

- [143] T. E. Hoff, H. J. Wenger, C. Herig, and R. W. Shaw Jr., "A Micro-Grid with PV, Fuel Cells, and Energy Efficiency," In Proceedings of the 1998 Annual Conference, American Solar Energy Society, pp. 225-230. 1998.
- [144] F. Katiraei, R. Iravani, N. Hatziargyriou, and A. Dimeas, "Microgrids Management: Control and Operation Aspects of Microgrids," IEEE Power and Energy Magazine, May/June, 2008.
- [145] N.W. A. Lidula, A.D. Rajapakse, "Microgrid Research: A Review of Experimental Microgrids and Test Systems," Renewable and Sustainable Energy Reviews, 15(2011) 186-202, 2011.
- [146] P. Basak, S. Chowdhury, S. Halder nee Dey, S.P. Chowdhury, "A Literature Review on Integration of Distributed Energy Resources in the Perspective of Control, Protection and Stability of Microgrid," Renewable and Sustainable Energy Reviews,16(2012) 5545-5556, 2012.
- [147] E. Planas, A. Gil-de-Muro, J. Andreu, I. Kortabarria, I. Martinez de Alegria, "General Aspects, Hierarchical Controls and Droop Methods in Microgrids: A Reviews," Renewable and Sustainable Energy Review, 17 (2013) 147-159, 2013.
- [148] S. Wang, "Intelligent Buildings and Building Automation," Taylor & Francis, Feb 1, 2010 - 248 pages.
- [149] North American Intelligent Building Roadmap, by Continental Automated Building Association (CABA),
<http://www.caba.org/resources/Documents/IBRM%202011%20Presentation%20March%209.pdf>
- [150] K. A. Jamsa, "Cloud Computing," Jones & Bartlett Publishers, Apr 30, 2012 - 322 pages.
- [151] A. S. Tanenbaum, "Computer Networks," Prentice Hall, 2003 - 891 pages.
- [152] W. Dargie and C. Poellabauer, "Fundamentals of Wireless Sensor Networks: Theory and Practice", John Wiley and Sons, 2010 ISBN 978-0-470-99765-9, pp. 168–183, 191–192
- [153] H. C. Ferreira, L. Lampe, J. Newbury, et al., "Power Line Communications: Theory and Applications for Narrowband and Broadband Communications over Power Lines," John Wiley & Sons, Jul 22, 2011 - 536 pages.
- [154] C. W. Gellings, "The Smart Grid: Enabling Energy Efficiency and Demand Response," Fairmont Press, Jun 1, 2009 - 300 pages.

- [155] H. Liang, B. J. Choi, W. Zhuang, et al., "Towards optimal energy store-carry-and-deliver for PHEVs via V2G system," in IEEE INFOCOM, 2012, pp. 1674-1682.
- [156] Y. Cao, T. Jiang, and Q. Zhang, "Reducing electricity cost of smart appliances via energy buffering framework in smart grid," IEEE Transactions on Parallel and Distributed Systems, vol. 23, no. 9, pp. 1572-1582, 2012.
- [157] Commercial Building Automation Systems, research report of Pike Research, <http://www.pikeresearch.com/research/commercial-building-automation-systems>
- [158] BACnet official website , <http://www.bacnet.org/>
- [159] LonWorks, official website, <https://www.echelon.com/technology/lonworks/>
- [160] HomeOS: Enabling smarter homes for everyone, Microsoft Research, <http://research.microsoft.com/en-us/projects/homeos/>
- [161] C. Dixon, R. Mahajan, S. Agarwal, et al, "The Home Needs an Operating System (and an App Store)," in HotNets IX, ACM, 20 October 2010.
- [162] D. Irwin, A. Wu, S. Barker, A. Mishra, et al, "Exploiting Home Automation Protocols for Load Monitoring in Smart Buildings," in Proceedings of the 3rd ACM Workshop on Embedded Sensing Systems for Energy-Efficiency in Buildings (BuildSys 2011), Seattle, WA, November 2011.
- [163] M. Chetty, J-Y. Sung, R. Grinter, "How Smart Homes Learn: The Evolution of the Networked Home and Household," in the Proceedings of UbiComp 2007, pages 127-144.
- [164] R. Grinter, W. Edwards, M. Chetty, et al, "The Ins and Outs of Home Networking: The Case for Useful and Usable Domestic Networking," ACM ToCHI 16, 2(2009), 8:1-8:28.
- [165] E. Shehan, W.K. Edwards, "Home Networking and HCI: What Hath God Wrought?" in the Proceedings of CHI 2007, pages 547-556.
- [166] P. Tolmie, A. Crabtree, T. Rodden, et al, "Making the Home Network at Home: Digital Housekeeping," in the Proceedings of ECSCW 2007, pages 331-350.
- [167] M. Mazurek, J. Arsenault, J. Breese, et al, "Access Control For Home Data Sharing: Attitudes, Needs And Practices," in the Proceedings of CHI 2010, pages 645-654.

- [168] T. Kim, L. Bauer, J. Newsome, et al, "Challenges in Access Right Assignment for Secure Home Networks," in the Proceedings of HotSec 2010.
- [169] E. Poole, M. Chetty, R. Grinter, et al, "More than Meets the Eye: Transforming the User Experience of Home Network Management," in the Proceedings of DIS 2008, pages 455-464.
- [170] J. Rode, E. Toye, A. Blackwell, "The Domestic Economy: a Broader Unit of Analysis for End User Programming," in the Proceedings of CHI 2005, pages 1757-1760.
- [171] HomePNA alliance, official website, <http://www.homepna.org/>
- [172] V. Oksman, "G.hn: The New ITU-T Home Networking Standard," IEEE Communications Magazine, Volume: 47, Issue: 10 Page(s): 138-145.
- [173] Home Grid Forum, official website, <http://www.homegridforum.org/>
- [174] T. Hootman, "Net Zero Energy Design: A Guide for Commercial Architecture," John Wiley & Sons, Sep 25, 2012 - 464 pages.
- [175] A.J. Marszal, P. Heiselberg, J.S. Bourrelle, et al, "Zero Energy Building—A review of definitions and calculation methodologies," Energy and Buildings, pp 971-979, Vol. 43, Issue 4, 2010.
- [176] J. Yudelson, "The Green Building Revolution," Island Press, Oct. 30, 2007 - 272 pages
- [177] United States Environment Protection Agency (EPA): Green Building, [Online Webpage], <http://www.epa.gov/greenbuilding/>
- [178] Tyson Research Center, Washington University in Saint Louis, <http://tyson.wustl.edu/lc/index.php/>
- [179] J. Lu, T. Sookoor, V. Srinivasan, et al., "The Smart Thermostat: Using Occupancy Sensors To Save Energy In Homes," Proc. of the 8th ACM Conference on Embedded Networked Sensor Systems (SenSys '10), Zurich, Switzerland, Nov. 3-5, 2010, Pages 211-224.
- [180] G. Gao, K. Whitehouse, "The Self-Programming Thermostat: Optimizing Setback Schedules Based On Home Occupancy Patterns," in the Proceedings of the First ACM Workshop on Embedded Sensing Systems for Energy-Efficiency in Buildings, November 03-03, 2009, Berkeley, California.
- [181] Nest Learning Thermostat, <http://www.nest.com/>

- [182] Life-Cycle Costing Manual for the Federal Energy Management Program, National Institute of Standards and Technology (NIST), 1995 edition,
<http://fire.nist.gov/bfrlpubs/build96/PDF/b96121.pdf>
- [183] Bright Green Buildings, by Continental Automated Building Association (CABA),
<http://www.caba.org/brightgreen>
- [184] Oregon Sustainability Center, <http://www.oregonsustainabilitycenter.org/>
- [185] In-Home Display Units: An Evolving Market, Part 1, IDC, March 4, 2008, 24 pages.
- [186] Washington University Green Cup Competition, <http://greencup.wustl.edu>
- [187] Washington University Green Lab Initiative, <http://greenlabs.wustl.edu/>
- [188] European Commission Smart Cities and Communities Initiatives,
http://ec.europa.eu/energy/technology/initiatives/smart_cities_en.htm
- [189] L. Atzori, A. Lera, G. Morabito, "The Internet of Things: A Survey," Computer Networks (Elsevier), pp 2787-2805, Vol. 54, Issue 15, October 2010.

Vita

Jianli Pan

Education

Ph.D., Washington University, Computer Engineering, May 2014.

M.S., Washington University, Computer Engineering, May 2010.

M.S., Beijing University of Posts and Telecommunications, Information Engineering, April 2004.

B.S., Nanjing University of Posts and Telecommunications, Electrical Engineering, July 2001.

Publications

Journals (including submitted):

Jianli Pan, Raj Jain, Subharthi Paul, "Energy Efficiency Evaluation and Network Architecture Design and Prototyping for the Consumer-side Smart Grids of Buildings," submitted to IEEE Journal on Selected Areas in Communications (JSAC), Special issue on Smart Grid Communications, 2013.

Jianli Pan, Raj Jain, Subharthi Paul, "A Survey of Energy Efficiency in Buildings and Microgrids using Networking Technologies," accepted by IEEE Communications Surveys and Tutorials, Special issue on Energy and Smart Grid, 2014.

Jianli Pan, Raj Jain, Subharthi Paul, "Enhanced Evaluation of the Inter-domain Routing System for Balanced Routing Scalability and New Internet Architecture Deployment," IEEE Systems Journal, September, 2013.

Subharthi Paul, Raj Jain, Jianli Pan, et al, "Application Delivery Multi-Cloud Environments using Software Defined Networking," accepted by Computer Networks (Elsevier), 2013.

Jianli Pan, Raj Jain, Subharthi Paul, and Chakchai So-In, "MILSA: A New Evolutionary Architecture for Scalability, Mobility, and Multihoming in the Future Internet," IEEE Journal on Selected Areas in Communications (JSAC), Special issue on Routing Scalability, Vol. 28, Issue 8, pp 1344-1362, October 2010.

Jianli Pan, Raj Jain, Subharthi Paul, "A Survey of Research on Future Internet Architectures," IEEE Communications Magazine, Vol. 49, No. 7, July 2011, pp. 26-36.

Chakchai So-In, Raj Jain, Subharthi Paul, and Jianli Pan, "Virtualization Architecture using the ID/Locator Split Concept for Future Wireless Networks (FWNs)," *Computer Networks (Elsevier), Special Issue on Wireless for the Future Internet*, Vol. 55, Issue 2, pp. 415-430, February 2011.

Subharthi Paul, Jianli Pan, and Raj Jain, "Architectures for the Future Networks and the Next Generation Internet: A Survey," *Computer Communications, UK*, Volume 34, Issue 1, Pages 2-42, 15 January 2011.

Chakchai So-In, Raj Jain, Subharthi Paul and Jianli Pan, "Virtual ID: ID/Locator Split in a Mobile IP Environment for Mobility, Multihoming and Location Privacy for the Next Generation Wireless Networks," *International Journal of Internet Protocol Technology 2010 - Vol. 5, No.3*, pp. 142-153.

Conferences:

Subharthi Paul, Raj Jain, Jianli Pan, et al, "OpenADN: A Case for Open Application Delivery Networking," in the Proceedings of IEEE ICCCN 2013, Nassau, Bahamas, July 30-August 2, 2013.

Jianli Pan, Raj Jain, Pratim Biswas, et al., "Toward an Energy-Proportional Building Prospect: Evaluation and Analysis of the Energy Consumption in a Green Building Testbed," in the Proceedings of IEEE Energytech 2013, Cleveland, OH, May 21-23, 2013.

Jianli Pan, Raj Jain, Subharthi Paul, "Nine Lessons Learned From a Green Building Testbed: a Networking and Energy Efficiency Perspective," in Proceedings of IEEE World Congress on Sustainable Technologies (WCST-2013), December 9-12, 2013, London, UK.

Jianli Pan, Raj Jain, Subharthi Paul, "A Novel Incremental-Deployable Multi-granularity Multihoming Framework for the Future Internet," in the Proceedings of IEEE Global Communications Conference (GLOBECOM) 2012, Anaheim, CA, December 3-7, 2012.

Jianli Pan, Raj Jain, Pratim Biswas, et al., "A Framework for Smart Location-Based Automated Energy Controls in a Green Building Testbed," in the Proceedings of IEEE EnergyTech 2012, Cleveland, OH, May 29-31, 2012.

Subharthi Paul, Raj Jain, Jianli Pan, "A Future Internet Architecture Based on De-conflated Identities," in the Proceedings of IEEE Global Communications Conference (GLOBECOM) 2010, Miami, FL, December 6-10, 2010.

Subharthi Paul, Raj Jain, Jianli Pan, "Multi-Tier Diversified Architecture for the Next Generation Internet," in the Proceedings of International Conference on Cloud Computing and Virtualization (CCV) 2010, Singapore, May 17-18, 2010.

Chakchai So-In, Raj Jain, Subharthi Paul, and Jianli Pan, "Virtual ID: A Technique for Mobility, Multi-Homing, and Location Privacy in Next Generation Wireless Networks," in the Proceedings of the Second IEEE International Workshop on Mobile IPv6 and Network-based Localized Mobility Management (MobiWorld), CCNC 2010, January 2010.

Subharthi Paul, Raj Jain, and Jianli Pan, "An Identifier/Locator Split Architecture for Exploring Path Diversity through Site Multi-homing - A Hybrid Host-Network Cooperative Approach," in the Proceedings of IEEE International Conference in Communications (ICC) 2010, Cape Town, South Africa, 23-27 May, 2010.

Jianli Pan, Subharthi Paul, Raj Jain, "Hybrid Transition Mechanism for MILSA Architecture for the Next Generation Internet," in the Proceedings of IEEE Globecom Workshop on Future Internet (FutureNet II) 2009, Honolulu, Hawaii, 30 November - 4 December 2009.

Jianli Pan, Raj Jain, Subharthi Paul, Mic Bowman, Xiaohu Xu, Shanzhi Chen, "Enhanced MILSA Architecture for Naming, Addressing, Routing and Security Issues in the Next Generation Internet," in the Proceedings of IEEE International Conference on Communications (ICC) 2009, Dresden, Germany, 14 June - 18 June 2009.

Jianli Pan, Subharthi Paul, Raj Jain, Mic Bowman, "MILSA: A Mobility and Multihoming Supporting Identifier Locator Split Architecture for Naming in the Next Generation Internet," in the Proceedings of IEEE Global Communications Conference (GLOBECOM) 2008, New Orleans, LA, USA, 30 November - 4 December 2008.

Subharthi Paul, Raj Jain, Jianli Pan, Mic Bowman, "A Vision of the Next Generation Internet: A Policy Oriented Perspective," Proceedings of British Computer Society (BCS) International Conference on Visions of Computer Science, Imperial College, London, September 22-24, 2008.

Chakchai So-In, Raj Jain, Subharthi Paul, and Jianli Pan, "A Policy Oriented Multi-Interface Selection Framework for Mobile IPv6 Using the ID/Locator Split Concepts in the Next Generation Wireless Networks," Proceedings of the 2nd International Conference on Computer and Automation Engineering (ICCAE 2010), Singapore, February 26 - 28.

Subharthi Paul, Raj Jain, Jianli Pan, Chakchai So-in, "Multi-Tier Diversified Service Architecture for Internet 3.0: The Next Generation Internet," WUSTL CSE Technical Report No. WUCSE-2010-31, June 23, 2010,

Subharthi Paul, Jianli Pan, and Raj Jain, "Architectures for the Future Networks and the Next Generation Internet: A Survey," WUSTL Technical Report, WUCSE-2009-69, October 2, 2009, 59 pp.

Wanjing Wang, Shanzhi Chen, and Jianli Pan, “A new method for multi-homing and multi-interface address selecting based on Mobile IPv6” , 2007 International Conference on Broadband Network & Multimedia Technology (IC-BNMT), Beijing, China, September, 2007.

Jianli Pan, Shanzhi Chen, “A Mobile IPv6 firewall traversal scheme integrating with AAA”, In Proceedings of the 2nd IEEE WiCOM (WiCOM'06), Wuhan, China, September, 2006.

Jianli Pan, Yun Hu, Yixian Yang, “Classification and research on the architecture of the Distributed Intrusion Detection System (DDoS)”(in Chinese), In Proceedings of the 1st National Natural Science Foundation Conference on Network and Information Security Research, Beijing, 2003.

PATENT:

Jianli Pan, Tao Yu, and Shanzhi Chen, “Method and apparatus for the firewall traversal problem in mobile environments”, Docket Number 200610001438.7, patent granted in Aug 2009, China.