

Architectures for the Next Generation Internet and the Future Networks



RAJ JAIN

Washington University in Saint Louis

Saint Louis, MO 63130

Jain@cse.wustl.edu

<http://www.cse.wustl.edu/~jain/>

A tutorial presented at IEEE International Conference on
Communications (ICC) 2011, Kyoto, Japan, June 9, 2011



1. Why Next Gen?
2. Internet 3.0
3. Content Centric Networks
4. Challenged Networks
5. Routing Architectures: Open Flow, ID-Locator Split Proposals
6. Next Generation Testbeds

Future Internet Projects

- ❑ In 2005 US National Science Foundation started a large research and infrastructure program on next generation Internet
- ❑ Q: How would you design Internet today? Clean slate design.
- ❑ “Future Internet Design” (FIND): 48+ projects
 - ❑ Stanford, MIT, Berkeley, CMU, ...
 - ❑ “An Architecture for Diversified Internet” at WUSTL
- ❑ “Global Environment for Networking Innovations” (GENI): 29+ projects
- ❑ European Union: 7th Framework program
- ❑ Japan: AKARI (A small light in the dark pointing to the future)
- ❑ China, Korea, Australia, ...20+ countries

Ref: S. Paul, J. Pan, R. Jain, "Architectures for the Future Networks and the Next Generation Internet: A Survey," Accepted for publication in Computer Communications, July 2010, 72 pp.,

<http://www.cse.wustl.edu/~jain/papers/i3survey.htm>

Why to worry about Future Internet?



Billion dollar question!

Key Problems with Current Internet

1. Security:

Fundamental architecture design issue
Control+Data are intermixed
Security is just one of the policies.



2. No concept of **ownership**

(except at infrastructure level)

Difficult to represent organizational, administrative hierarchies and relationships. Perimeter based.

⇒ Difficult to enforce organizational policies

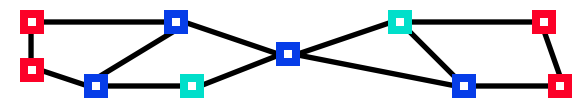
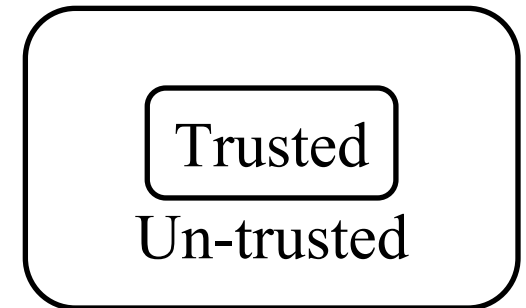

Realms

Problems (cont)

3. Identity and location in one (IP Address)
Makes mobility complex.
4. Assumes live and awake end-systems
Does not allow communication while sleeping.
Many energy conscious systems today sleep.
5. No representation for real end system: the human.



Ref: R. Jain, "Internet 3.0: Ten Problems with Current Internet Architecture and Solutions for the Next Generation," Proceedings of Military Communications Conference (MILCOM 2006), Washington, DC, October 23-25, 2006

Names, IDs, Locators



Name: John Smith

ID: 012-34-5678

Locator:

1234 Main Street
Big City, MO 12345
USA

- ❑ Locator changes as you move, ID and Names remain the same.
- ❑ **Examples:**
 - Names: Company names, DNS names (Microsoft.com)
 - IDs: Cell phone numbers, 800-numbers, Ethernet addresses, Skype ID, VOIP Phone number
 - Locators: Wired phone numbers, IP addresses

Future Internet: Areas of Research

1. New architectures
2. Security
3. Content Delivery Mechanisms
4. Delay Tolerant Networking
5. Management and Control Framework
6. Service Architectures
7. Routing: New paradigms
8. Green Networking
9. Testbeds

Ref: S. Paul, J. Pan, R. Jain, "Architectures for the Future Networks and the Next Generation Internet: A Survey," Accepted for publication in Computer Communications, July 2010, 72 pp., <http://www.cse.wustl.edu/~jain/papers/i3survey.htm>

Five Trends in Networking

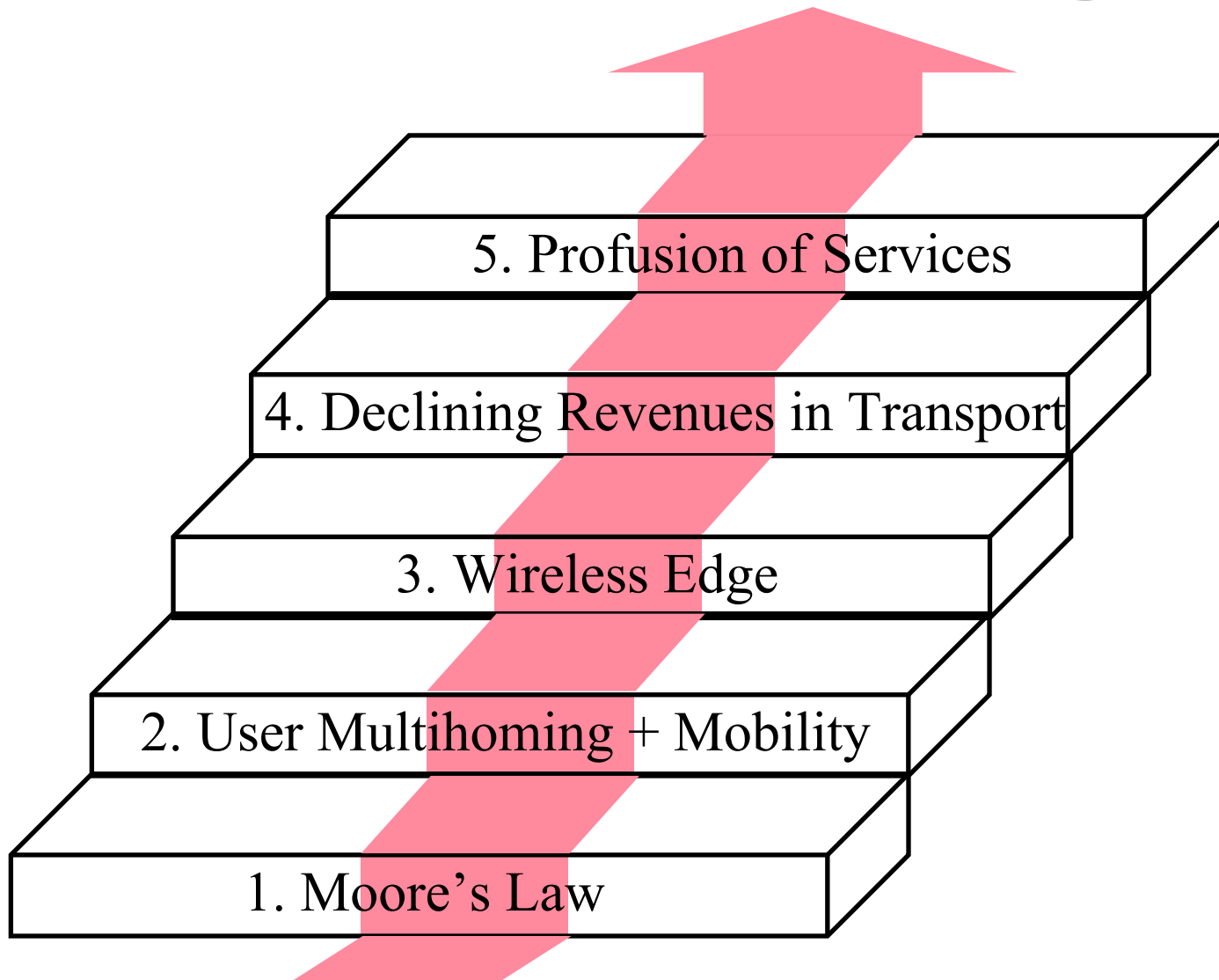

Trend 1: Moore's Law

- ❑ Computing Hardware is cheap
- ❑ Memory is plenty

⇒ Storage and computing (Intelligence) in the net

- ❑ Energy ↔ Matter
- ❑ Space ↔ Time
- ❑ Communication in Space ↔ Communication in Time

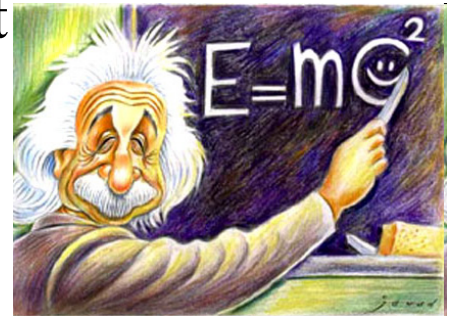

- ❑ Link

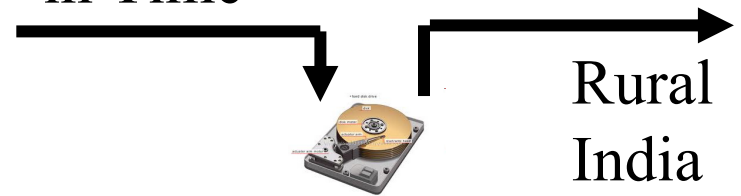

- ❑ Storage (USB, Caching,...)

Next Gen nets will use storage in networks, e.g., DTN, CCN

Trend 2: Multihoming + Mobility

- ❑ Centralized storage of info
 - ❑ Anytime Anywhere computing
 - ❑ Dynamically changing Locator
 - ❑ User/Data/Host/Site/AS Multihoming
 - ❑ User/Data/Host/Site Mobility
- ⇒ ID/Locator Split

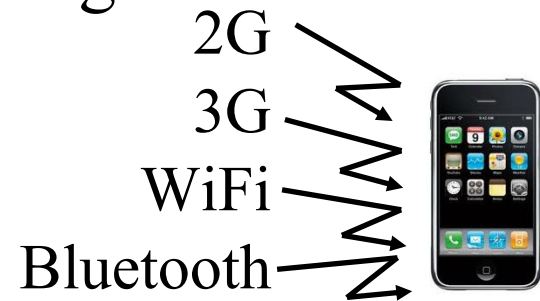

**Mobile Telephony already distinguishes ID vs. Locator
We need to bring this technology to IP.**

Trend 3: Wireless Edge



1. Billions \Rightarrow Scalable
2. Heterogeneous \Rightarrow Customization of content
3. Slow \Rightarrow Bottleneck \Rightarrow Receiver Control
(IP provides sender controls but no receiver controls)

Need to design from receiver's point of view

Trend 4: Declining Revenues in Transport

- ❑ Telecom carriers' disappearing revenues in basic transport
- ❑ New opportunities in apps and Intelligent transport



2000 FedEx
Trucking



2010 FedEx Office
Distribution Centers, Email, ...

Future of ISPs is to go beyond best effort trucking services

Trend 5: Profusion of Services



- ❑ Almost all top 50 Internet sites are services [Alexa]
- ❑ Smart Phones: iPhone, Android Apps
 - ⇒ New globally distributed services, Games, ...
 - ⇒ More clouds, ...

Networks need to support efficient service setup and delivery



2. Internet 3.0

- ❑ Internet 3.0: Next Generation Internet
- ❑ Internet Generations
- ❑ Organizational Representation
- ❑ User- Host- and Data Centric Models
- ❑ Policy-Based Networking Architecture
- ❑ Multi-Tier Object-Oriented View
- ❑ Virtualization

Internet 3.0: Next Generation Internet

- ❑ Internet 3.0 is the name of the Washington University project on the next generation Internet
- ❑ Goal 1: Represent the commercial reality of distributed Internet ownership and organization
- ❑ Goal 2: Develop a clean slate architecture to overcome limitations of the current internet
- ❑ Goal 3: Develop an incremental approach to implement the architecture

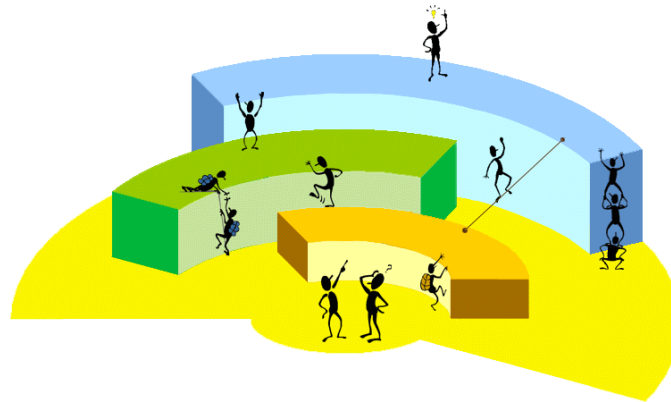

Internet Generations

❑ Internet 1.0 (1969 – 1989)

- Single ownership \Rightarrow Trust
- complete knowledge
- Algorithmic optimality \Rightarrow RIP

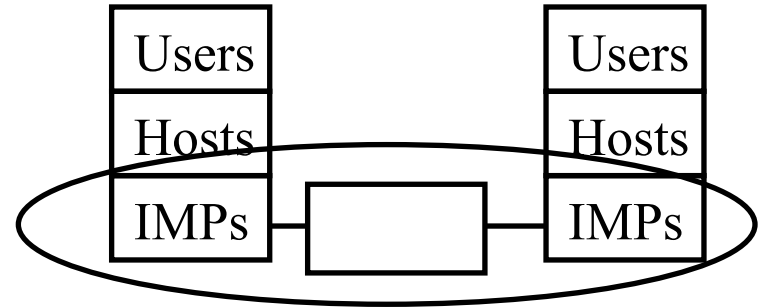

❑ Internet 2.0 (1989–2009) Commerce

- Multiple ownership of infrastructure \Rightarrow Distrust, **Security**
- No knowledge of internal topology and resources
- *Policy based* routing \Rightarrow BGP

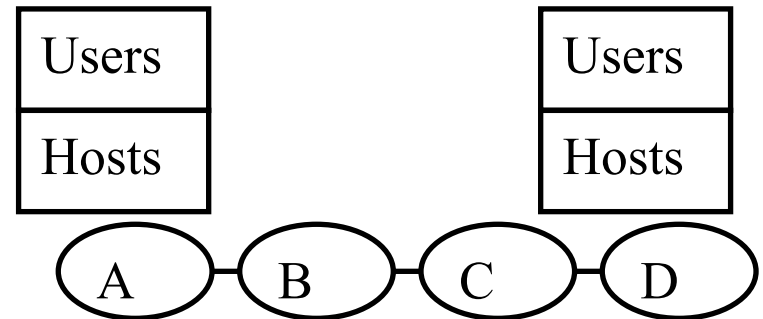

❑ Internet 3.0 (2009–2029) Commerce

- Users, Content, Host ownership
- Requirements, Service Negotiation
- Mobility of users and distributed data

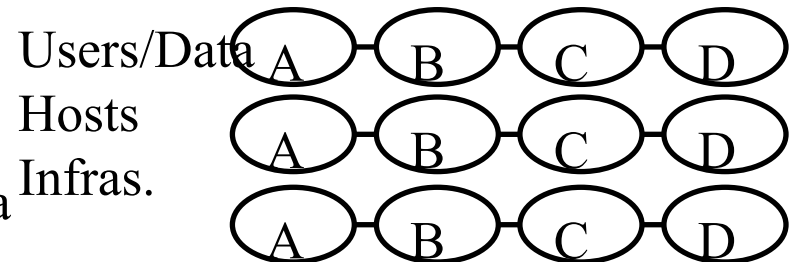

Service Center Evolution

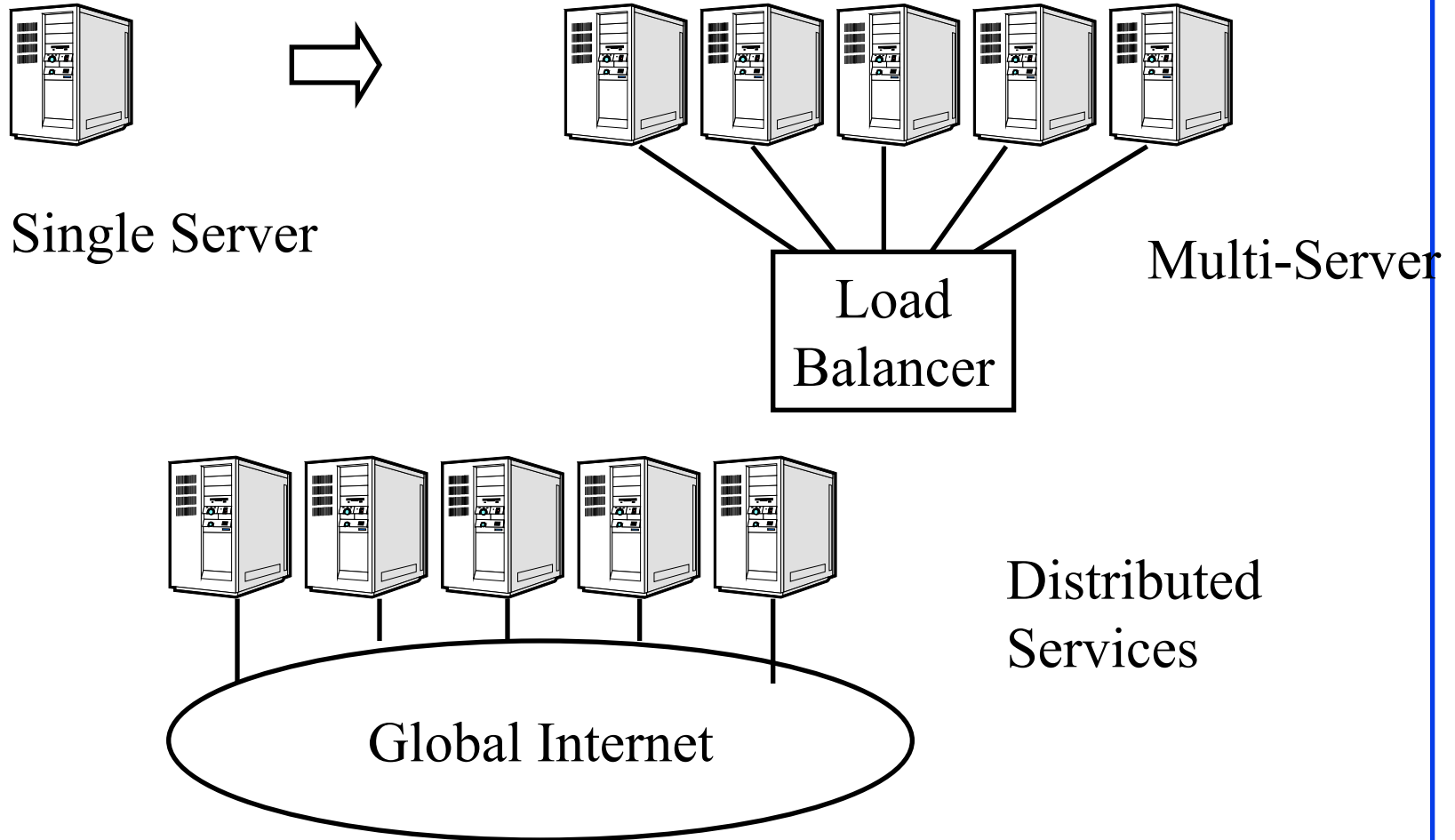

Need a distributed load balancer for globally distributed datacenters

Globally Distributed Services

- ❑ Scale \Rightarrow Global \Rightarrow Distributed \Rightarrow Multihomed
- ❑ Internet 1.0 is designed for point-to-point communication
- ❑ Significant opportunities for improvement for global services

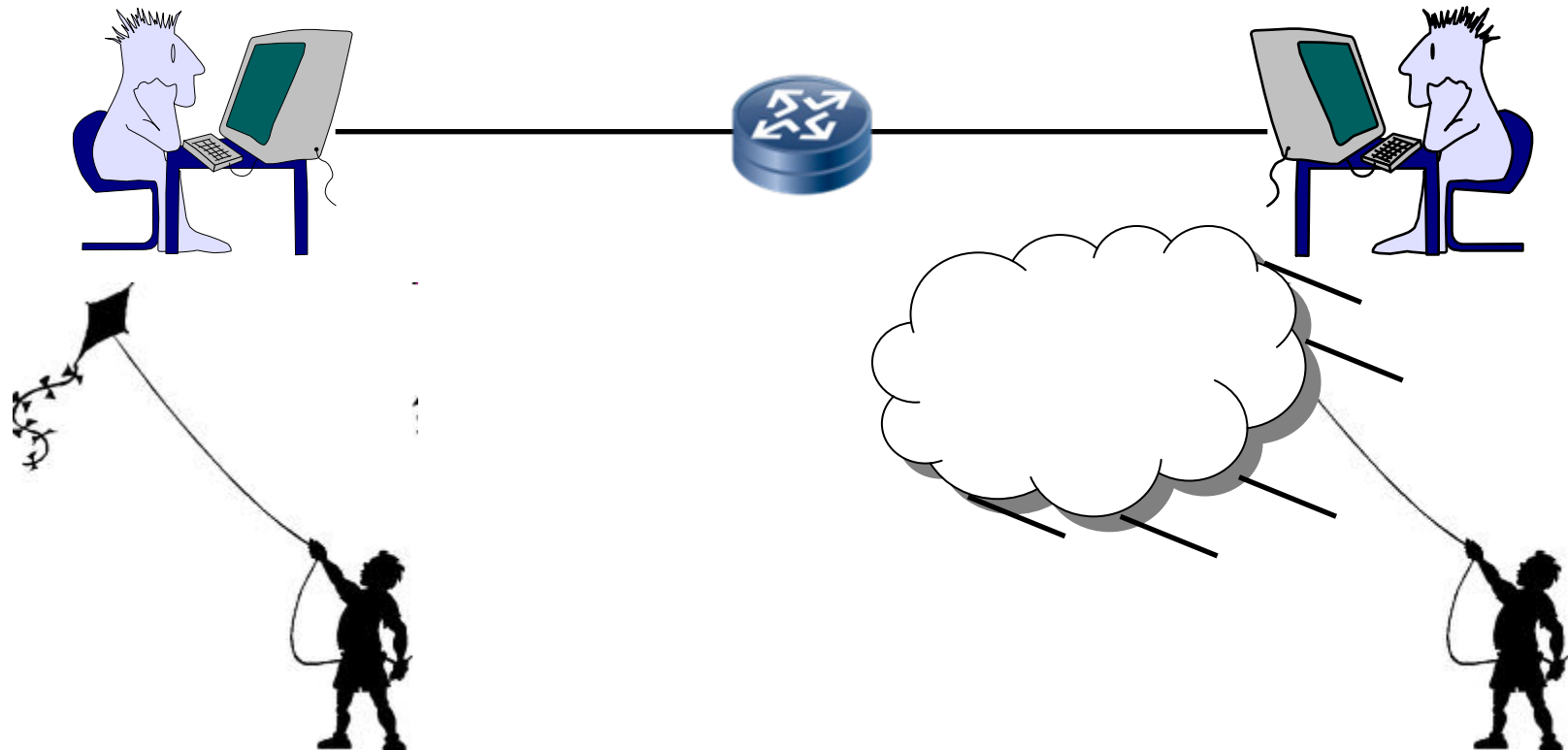

Globally Distributed Services (Cont)

- It's the service responsibility to find the right server for the client

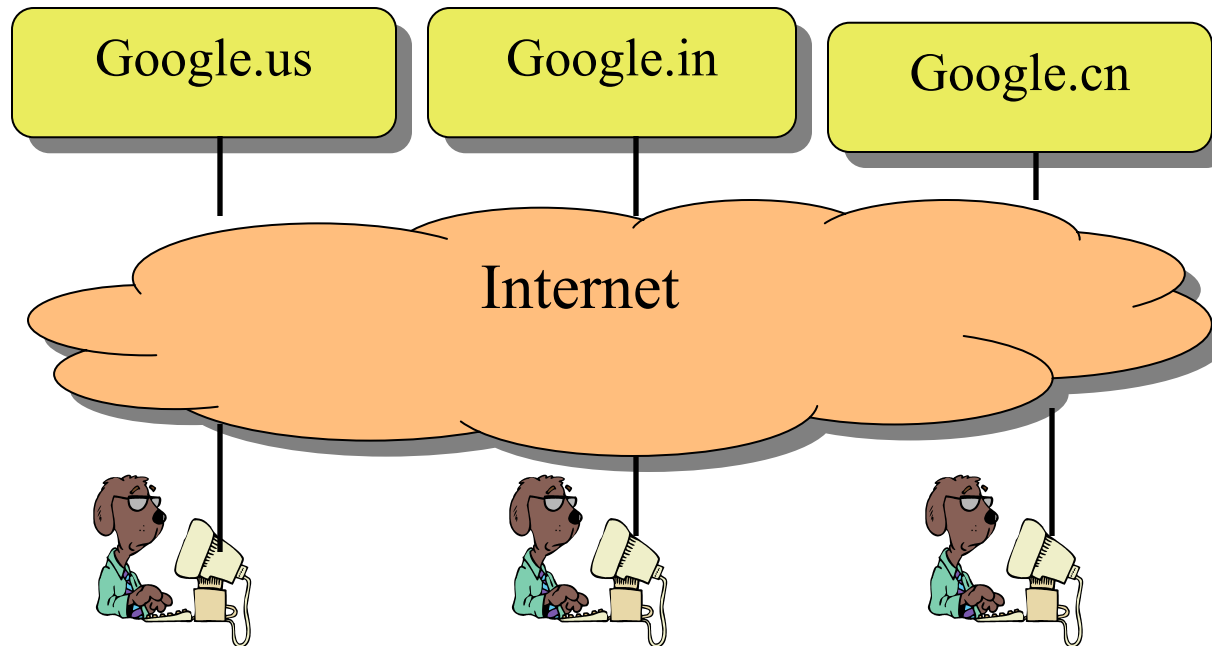

Trend: Private Smart WANs

- ❑ Services totally avoid the Internet core \Rightarrow Many private WANs
- ❑ Google WAN, Akamai \Rightarrow Rules about how to connect users

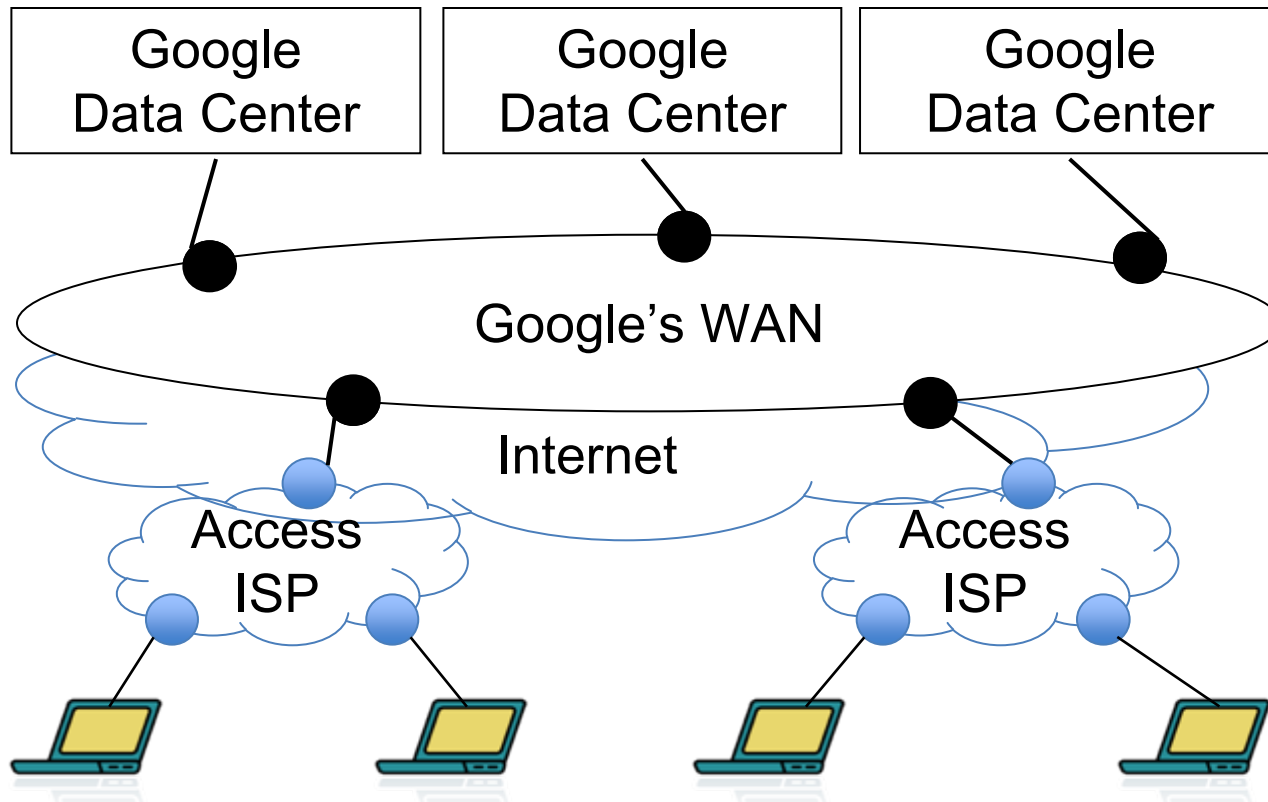

Opportunity for ISPs to offer these types of WAN services

OpenSDN

- ❑ High-Speed WAN architected for Service Delivery.
- ❑ Allows ASPs to quickly setup services

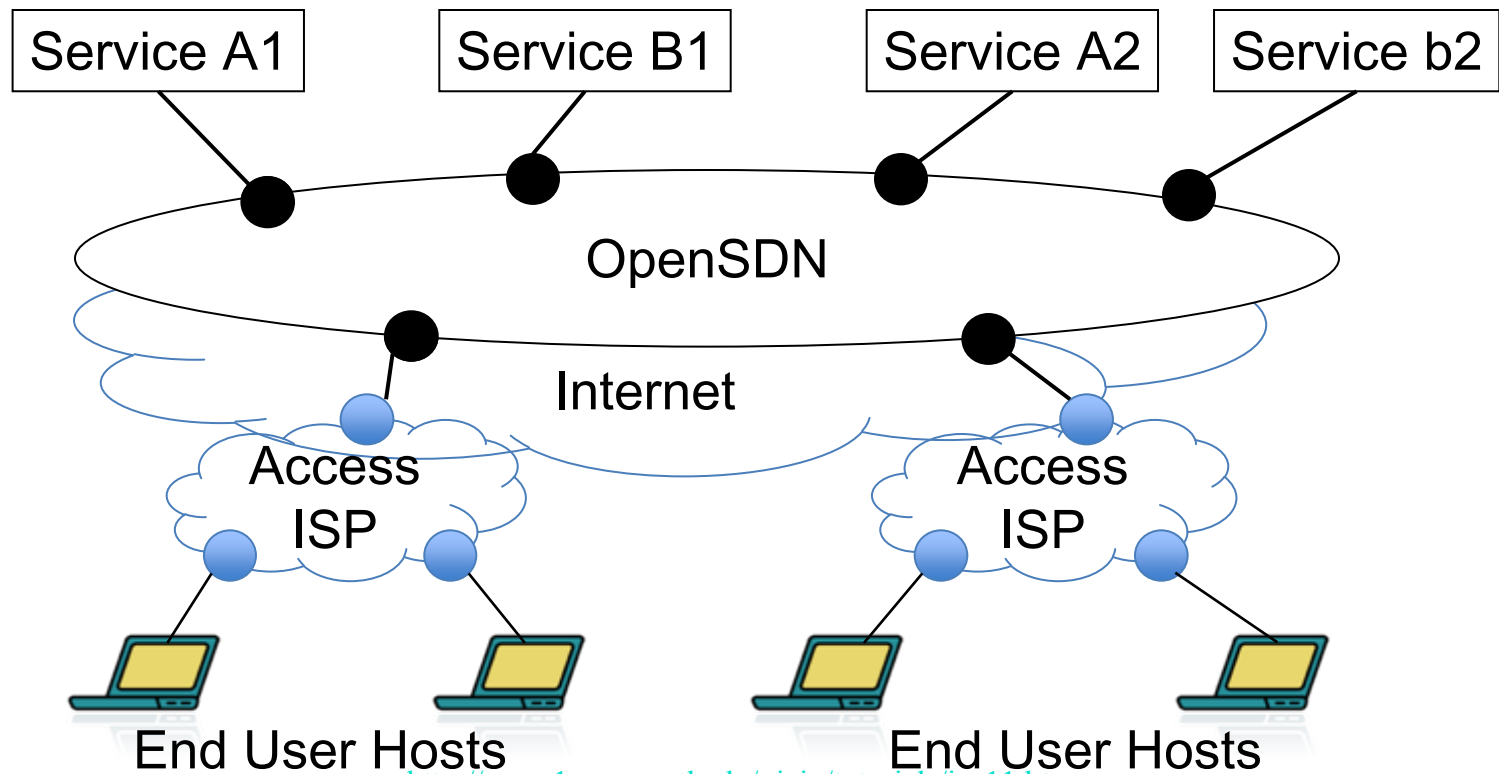

Ten Key Features that Services Need

1. **Replication**: Multiple datacenters appear as one
2. **Fault Tolerance**: Connect to B if A is down
3. **Load Balancing**: 50% to A, 50% to B
4. **Traffic Engineering**: 80% on Path A, 20% on Path B
5. **Flow based forwarding**: Movies, Storage Backup, ...
ATMoMPLS, TDMoMPLS, FRoMPLS, EoMPLS, ...
Packets in Access, Flows in Core
6. **Security**: Provenance, Authentication, Privacy, ...
7. **User Mobility**: Gaming/Video/... should not stop as the user moves
8. **Service composition**: Services using other services
9. **Customization**: Every service has different needs
10. **Dynamic Setup** \Rightarrow Networking as a Service

Five Arch Design Principles for Success

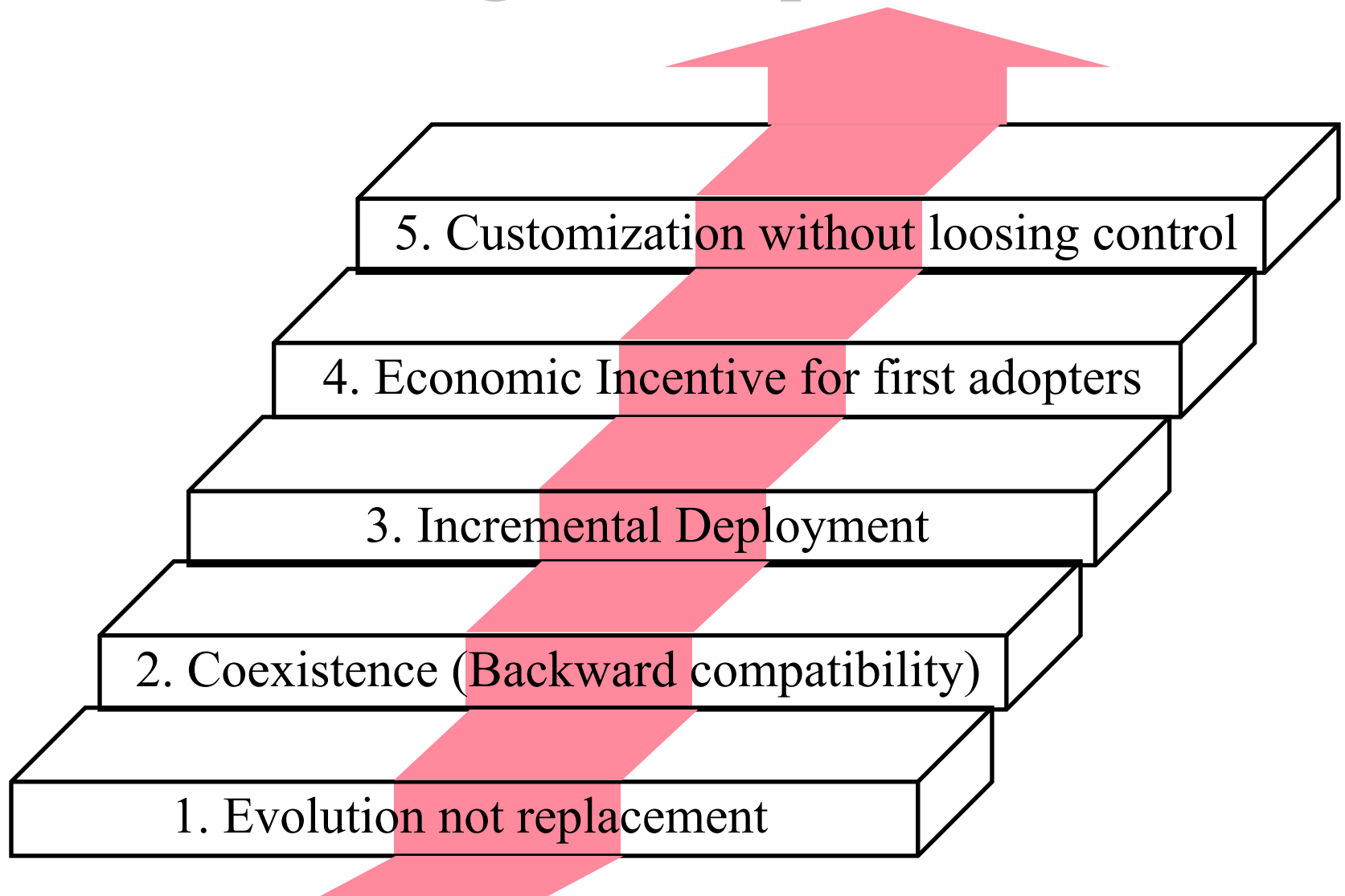

Networking: Failures vs Successes

- ❑ 1986: MAP/TOP (vs Ethernet)
- ❑ 1988: OSI (vs TCP/IP)
- ❑ 1991: DQDB
- ❑ 1994: CMIP (vs SNMP)
- ❑ 1995: FDDI (vs Ethernet)
- ❑ 1996: 100BASE-VG or AnyLan (vs Ethernet)
- ❑ 1997: ATM to Desktop (vs Ethernet)
- ❑ 1998: ATM Switches (vs IP routers)
- ❑ 1998: MPOA (vs MPLS)
- ❑ 1999: Token Rings (vs Ethernet)
- ❑ 2003: HomeRF (vs WiFi)
- ❑ 2007: Resilient Packet Ring (vs Carrier Ethernet)
- ❑ IntServ, DiffServ, ...



Technology alone does not mean success.

Five Architecture Design Principles

1. Evolution not replacement.
2. Coexistence (Backward compatibility):
Old on New. New on Old
3. Incremental Deployment
4. Economic Incentive for first adopters
5. Customization without losing control
(No active networks)

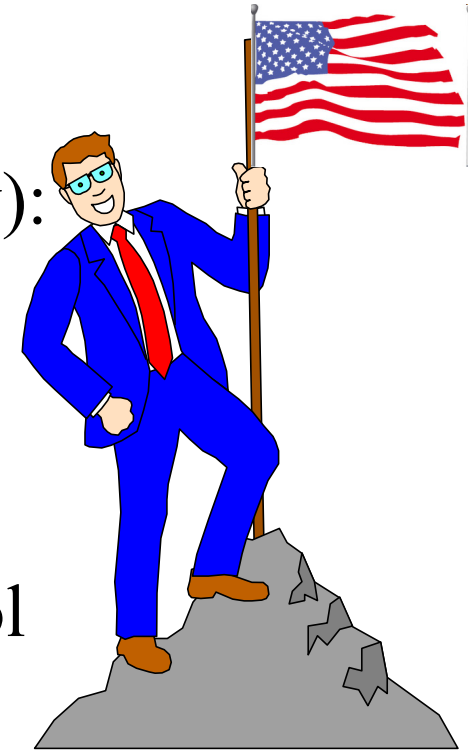

**Most versions of Ethernet followed these principles.
Many versions of IP did not.**

The Narrow Waist

- Everything as a service over service delivery narrow waist
- IP, HTTP, Content, Service delivery, ...

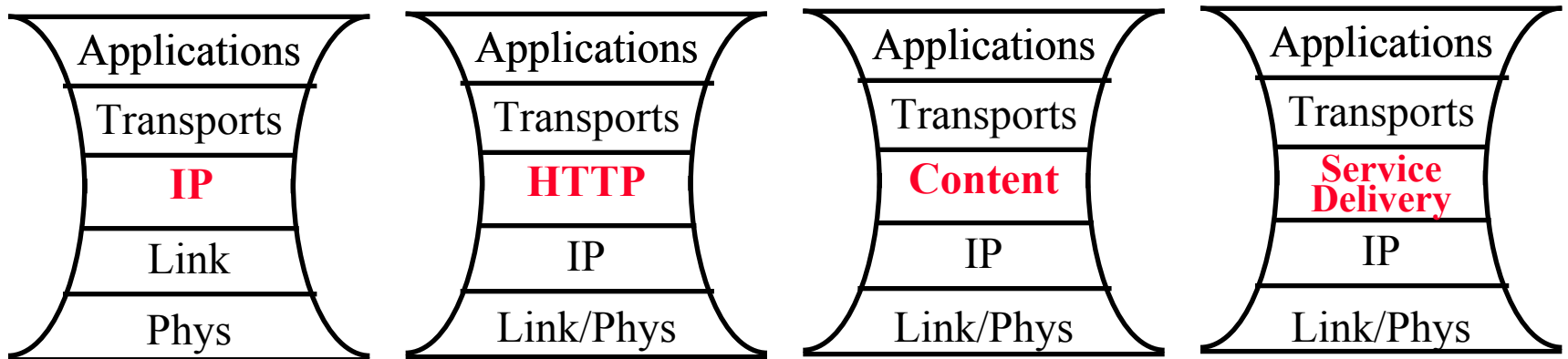



3. Content Centric Networks

- ❑ Content-Centric Networks (CCN)
- ❑ CCN Packets
- ❑ CCN Capable Routers Operation
- ❑ CCN Security

Content-Centric Networks

- ❑ IP cares about “**Where**”: forward packets from A to B
- ❑ Users care about “**What**”: Movie X
- ❑ Replace “packets” with “Data Objects” or “Interests” (requests)
- ❑ Replace “Addresses” with “Names of Objects”

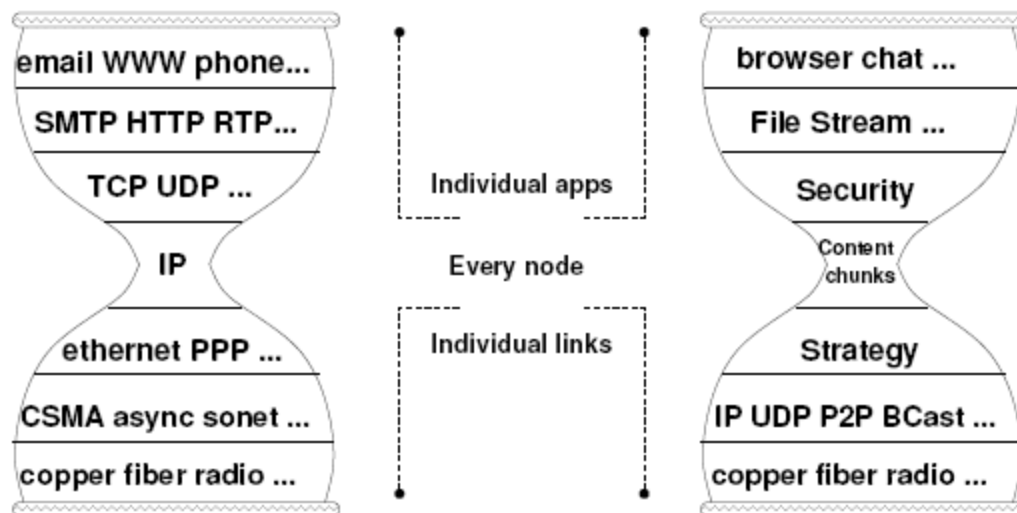

[JAC09]

Ref: [JAC09] V. Jacobson, et al, “Networking Named Content,” CoNEXT 2009, December 2009

CCN Packets

- ❑ Interest Packets: Request for Data

- ❑ Data Packets: Signed Data

- ❑ Longest prefix match is used as in IP addresses

`http://www.cse.wustl.edu/~jain/talks/ftp/in3_video` matches

`http://www.cse.wustl.edu/~jain/talks/ftp/in3_video/V00/S00`

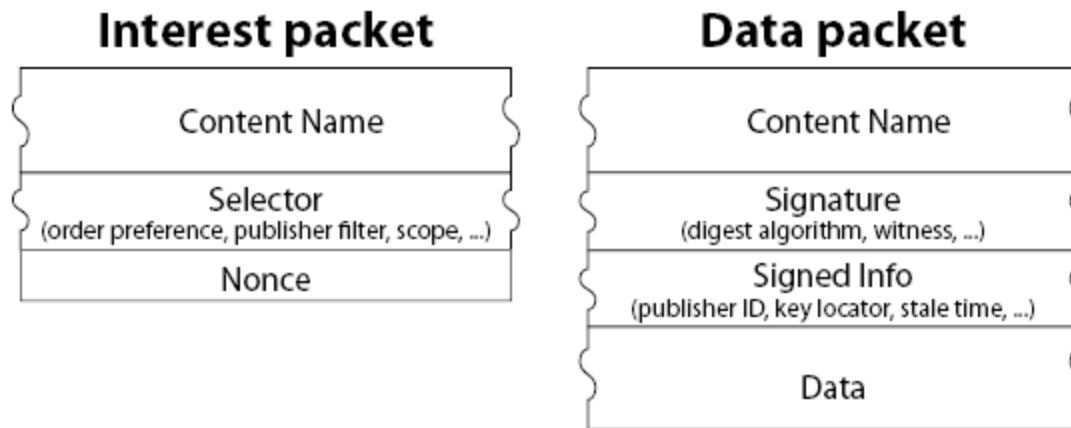

[JAC09]

CCN Capable Routers Operation

- ❑ **Content Store:** Local cache of data
- ❑ **Pending Interest Table (PIT):** Recent requests forwarded
- ❑ **Forwarding Information Base (FIB):** Known data locations
- ❑ **Faces:** Requesting processes and hardware interfaces

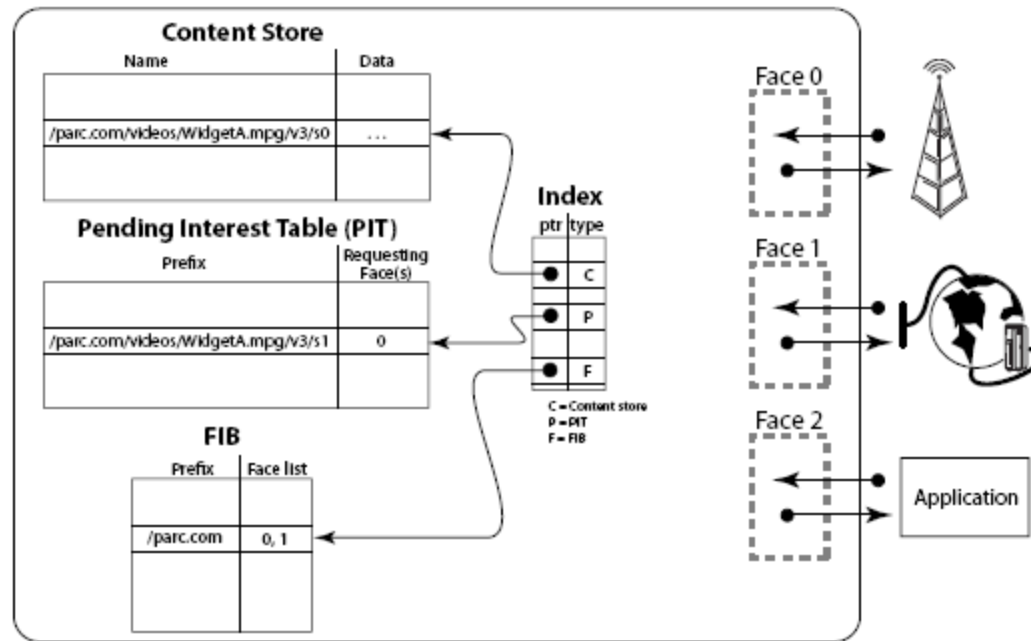

[JAC09]

Routers Operation (Cont)

- ❑ Applications send “Interest” in data X
- ❑ Router looks up in local store and sends if found
- ❑ Router looks up in PIT, if entry already exists (someone requested it recently) , adds the interest, face to the same entry
- ❑ Router looks up in FIB, if entry exists (data location is known), a PIT entry is made and the interest is multicasted to all faces in the FIB entry
- ❑ If there is no FIB entry, interest is discarded (router does not know how to get the data)
- ❑ When data arrives, Content Store match \Rightarrow duplicate, discard
PIT match \Rightarrow Forward to all faces
FIB match \Rightarrow No PIT \Rightarrow Unsolicited \Rightarrow Discard
- ❑ Data providers register their data \Rightarrow Creates FIB entries

CCN Security

- ❑ Data-Centric Security \Rightarrow Protections travel with the data
- ❑ All data is signed
- ❑ Data can be replicated or moved
- ❑ All data is versioned and is immutable once in the system
- ❑ IP and CCN routers can coexist. Public domain code available.

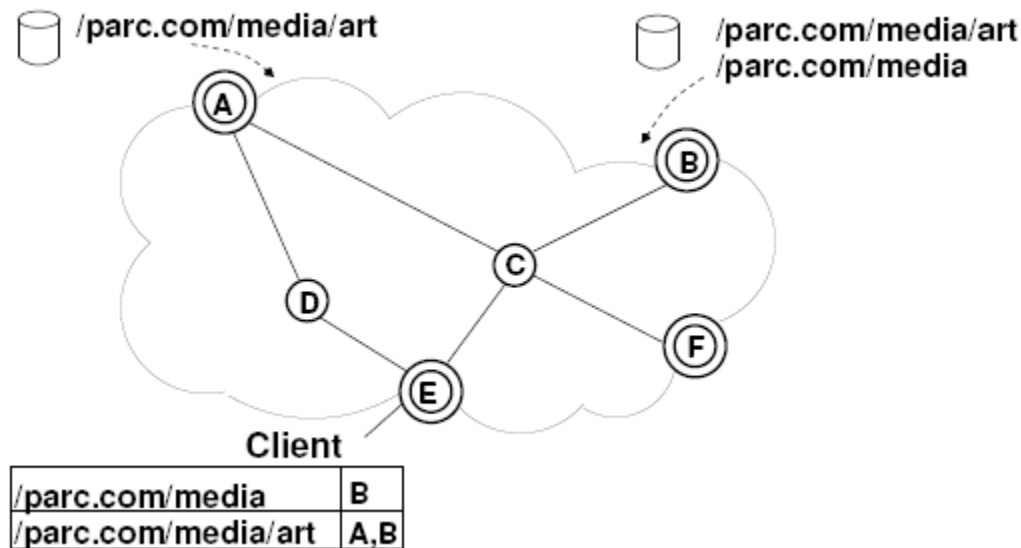

VOIP over CCN

- ❑ On-demand publishing: Data is produced only when some wants to connect
- ❑ Callee's phone registers a service
- ❑ Caller looks for the service
- ❑ Issue: Complexity/State proportional to # of flows/users



Ref: V. Jacobson, et al, "VoCCN: Voice over Content-Centric Networks," ACM ReArch 2009, Rome, Italy.



4. Challenged Networks

Challenged \Rightarrow End-to-end not continuous

E.g., DTN, Sensor, Ad-hoc, ...

- ❑ Delay/Disruption Tolerant Net (DTN)
 - Bundle Protocol
 - Bundle Delivery Options
 - Known Issues with Bundle Protocol
- ❑ Other Challenged environments

Delay/Disruption Tolerant Net (DTN)

- ❑ Intermittent Connectivity
- ❑ Long or variable delay
- ❑ Asymmetric data rates
- ❑ High Error Rates

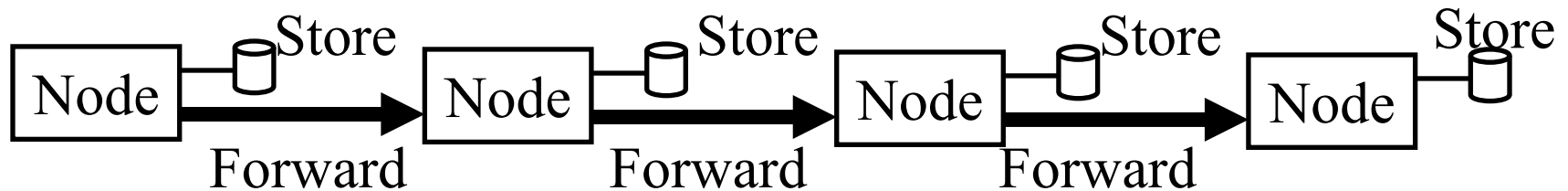

Bundle Protocol

- ❑ End-to-end protocol for DTNs
- ❑ Runs between application and transport
- ❑ Ties together heterogeneous regions
- ❑ Bundles can be fragmented or reassembled on the way

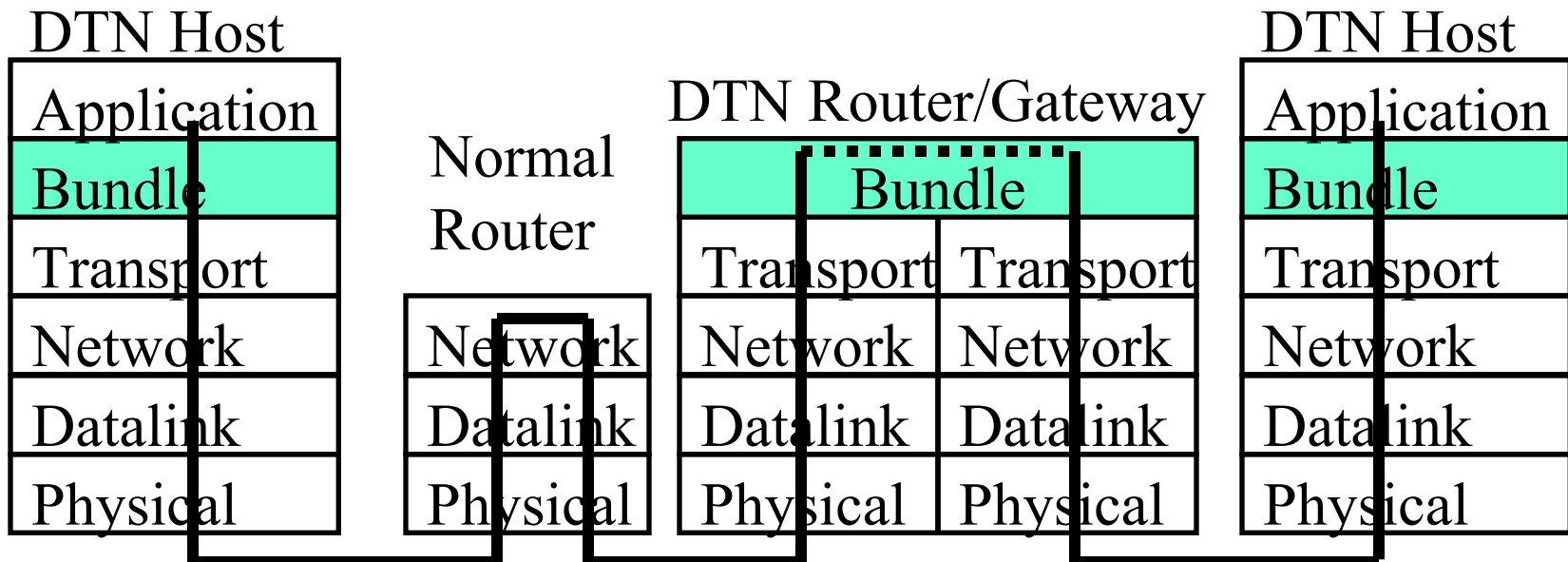

Bundle Protocol (Cont)

- ❑ Three Types of DTN Nodes: Hosts, Routers, Gateways (Convergence layer adapter)
- ❑ IPv6-like extension headers are used in bundle
- ❑ Custody transfer of bundles
- ❑ A node releases storage when someone else accepts custody
- ❑ End-to-End reliability can be achieved by requesting return receipt

Ref: [RFC4838, RFC 5050]

Bundle Delivery Options

1. Custody transfer requested
 2. Source custody acceptance required
 3. Report on bundle delivery
 4. Ack by application requested
 5. Report on bundle reception
 6. Report on custody acceptance
 7. Report on bundle forwarding
 8. Reporting on bundle deletion
- Priority of Delivery: Bulk, normal, exped.
 - Security: Confidentiality, Authentication, error detection
 - Notifications can be to another reply-to-entity

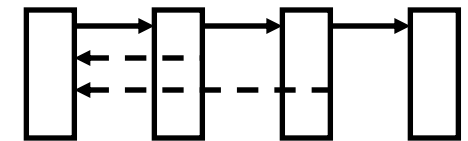
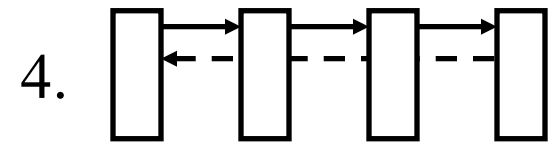
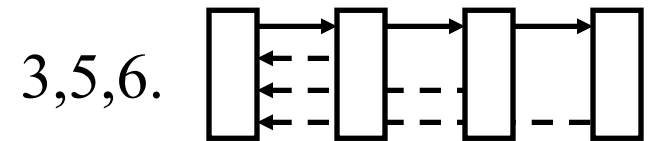
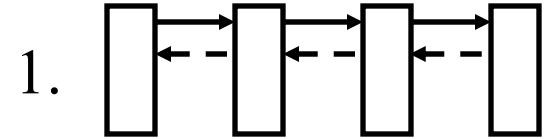

————— Bundle
 ← - - - Ack

Known Issues with Bundle Protocol

Specification in Development. Not yet defined:

- ❑ Operations for forming bundle protocol addresses
- ❑ Means for key exchange and security associations
- ❑ QoS mechanisms
- ❑ How to bind IDs to addresses
- ❑ Multiple different convergence layers
⇒ Multiple naming schemes ⇒ How to map?
- ❑ How to exchange routing information among regions?

Ref: L. Wood, W. Eddy, P. Holliday, "A Bundle of Problems," IEEE Aerospace conference, Big Sky, Montana, March 2009.

Other Challenged Environments

- ❑ **Delay/Fault tolerant Mobile Sensor Networks (DFT-MSN)** [1]: Adjust sleep and multicast for power conservation.
- ❑ **Postcards from the edge** [2]: Post office nodes cache data for mobile nodes.
- ❑ **Disaster day after networks (DANs)** [3]: Prioritized data transmission over network islands
- ❑ **Selectively Connected Networks (SCNs)** [4]: Proxy wakes up nodes only when necessary.

Ref: [1] Y. Wang and H. Wu, "Delay/Fault-Tolerant Mobile Sensor Network (DFT-MSN): A New Paradigm for Pervasive Information Gathering," IEEE Transactions on Mobile Computing, Vol 6, No 9, pp 1021-1034, 2007.

[2] R. Yates, D. Raychaudhuri, S. Paul, et al., "Postcards from the Edge: A Cache-and-Forward Architecture for the Future Internet," NSF NeTS FIND Initiative, <http://www.nets-find.net/Funded/Postcards.php>

[3] H. Luo, R. Kravets, T. Abdelzaher, "The-Day-After Networks: A First-Response Edge-Network Architecture for Disaster Relief," NSF NeTS FIND Initiative, <http://www.nets-find.net/Funded/DayAfterNet.php>

[4] M. Allman, K Christenson, B. Nordman, V. Paxson, "Enabling an Energy-Efficient Future Internet Through Selectively Connected End Systems," HotNets-VI, 2007.



5. Routing Architectures

- ❑ OpenFlow
- ❑ ID-Locator Split
 - Host Identity Protocol: HIP
 - ID Locator Split via Core-Edge Separation
 - LISP Protocol Details
 - MILSA

OpenFlow

- ❑ Allows researchers to run experimental protocols on production networks
- ❑ Each router/switch has a flow forwarding table
- ❑ Forwarding table is prepared by a central controller
- ❑ Vendors do not need to expose internal workings of their switches
- ❑ No need to program switches. Just program the central controller.

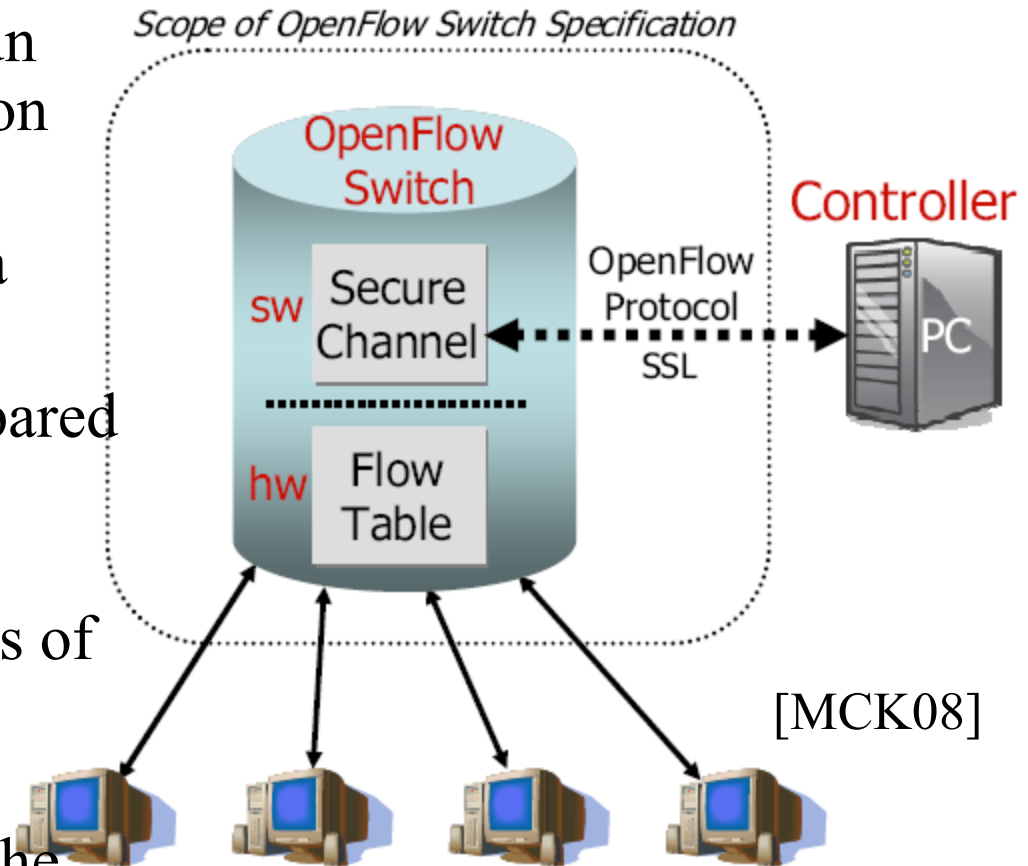

Ref: [MCK08] "OpenFlow: Enabling Innovation in Campus Networks," OpenFlow Whitepaper, March 2008

OpenFlow (Cont)

- ❑ Three Components:
 - Flow table: How to identify and process a flow
 - Secure Channel: Between controller and the switch
 - Open Flow Protocol: Standard way for a controller to communicate with a switch

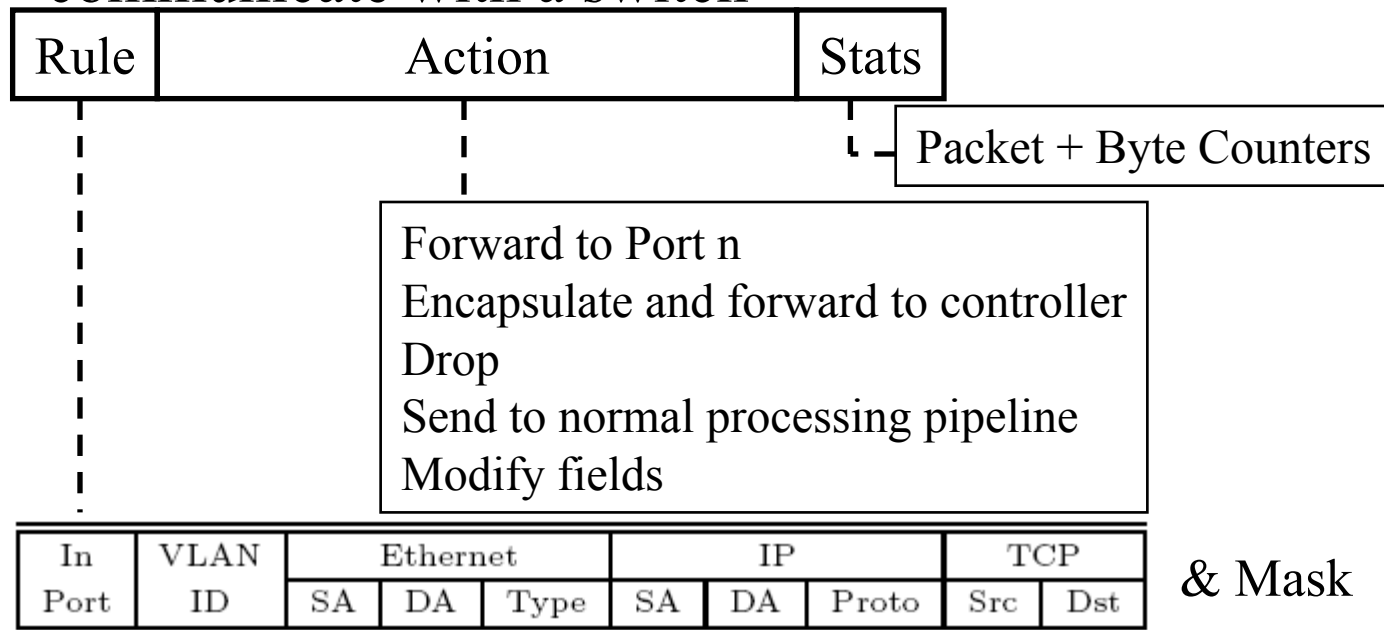

OpenFlow (Cont)

- ❑ TCAMs are used to match the fields
- ❑ Controller forwards the packets correctly as the mobile clients move
- ❑ Can handle non-IP networks
- ❑ OpenFlow Consortium is developing OpenFlow Switch Specification.
- ❑ Reference designs for Linux, Access points (OpenWRT), and NetFPGA (hardware)
- ❑ Combined packet and circuit switching
- ❑ Software defined networks

Ref: [MCK08], OpenFlowSwitch.org

Software Defined Networks

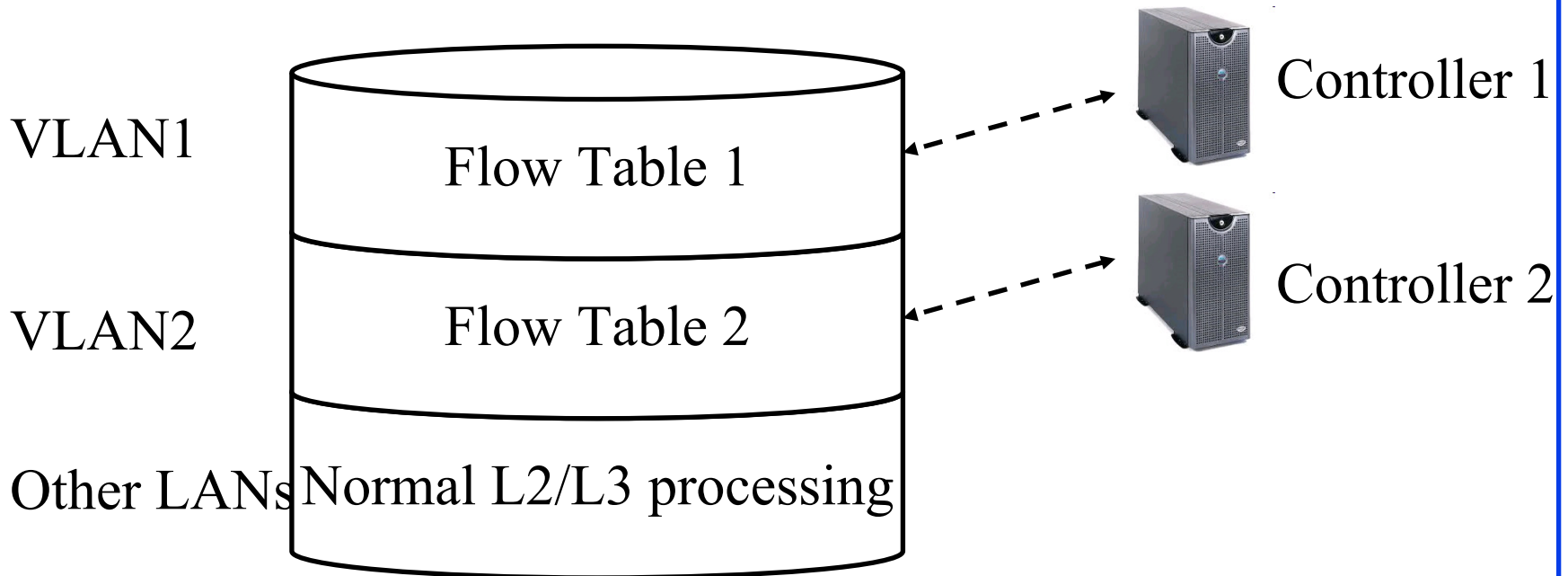

Reactive and Proactive Operation

Proactive

- ❑ Switch flow tables pre-populated by the controller
- ❑ No flow setup time
- ❑ Loss of control connection does not affect operation
- ❑ Many entries never triggered

Reactive

- ❑ First packet of the flow triggers new flow entries
- ❑ Flow setup time
- ❑ Limited operation if control connection lost
- ❑ Efficient use of flow table entries

OpenFlow allows both models

Current Limitations of OpenFlow

- ❑ Use all switch features (vary with products)
- ❑ New packet formats (non-IP, non-Ethernet, ...)
- ❑ Non-flow based applications
- ❑ Setup delay on new flows

ID-Locator Split

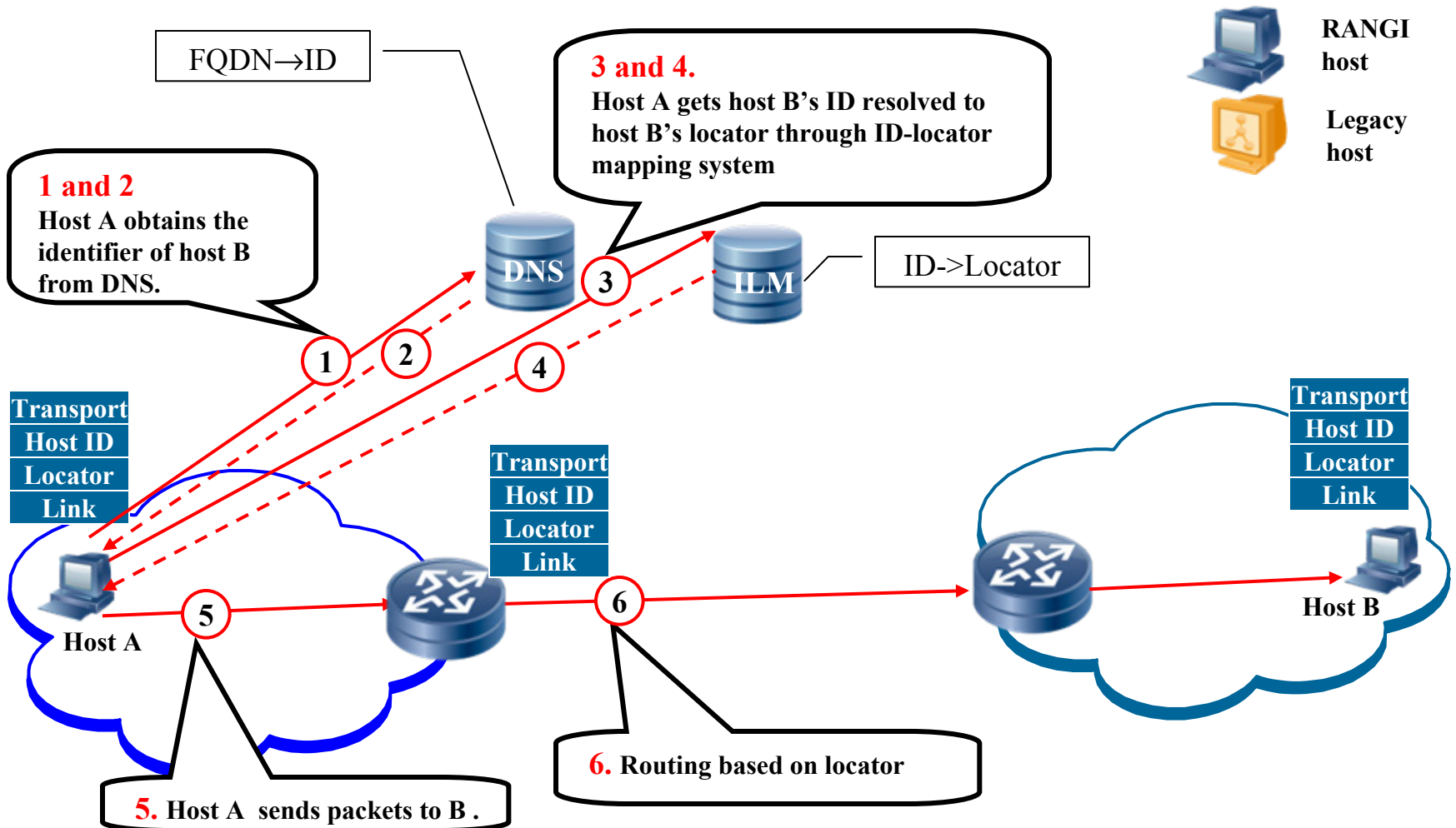

ID-Locator Split (Cont)

- ❑ Allows hosts to move
- ❑ Allows entire organizations to move
Allows organizations to change providers
- ❑ No need to use “Provider Independent (PI)” addresses
- ❑ Provider Aggregatable (PA) addresses are preferred since they result in shorter BGP tables
⇒ Scalable
- ❑ Several proposals for host-based ID-locator split:
HIP, Shim6, I3, and HI3
- ❑ All hosts have ID and global locators
- ❑ Allow mobility, multihoming, renumbering

HIP

- ❑ Host Identity Protocol
- ❑ 128-bit Host ID tag (HIT)
- ❑ TCP is bound to HIT. HIT is bound to IP address in the kernel
- ❑ Uses flat cryptographic based identifier
- ❑ Two Methods:
 - Locator registered using Update packets to DNS
 - ⇒ Does not allow fast mobility
 - Use rendezvous servers
 - ⇒ Does not adhere to organizational boundary
- ❑ Requires changes to end hosts

Ref: R. Moskowitz, P. Nikander and P. Jokela, "Host Identity Protocol (HIP) Architecture," IETF RFC4423, May 2006.

ID Locator Split via Core-Edge Separation

- ❑ Edge routing is based on ID.
Core routing based on global locators
- ❑ Requires no changes to end hosts.
Preferred solution for router vendors.
- ❑ Proposals: LISP, IVIP, DYNA, SIX/ONE, APT, TRRP
- ❑ LISP: Locator-ID Separation Protocol
- ❑ Uses IP-in-IP tunneling
- ❑ Edge routers translate IDs to routing locators and encapsulate
- ❑ No changes to core routers
- ❑ No centralized ID to locator mapping databases
- ❑ No support for host mobility, multihoming, traffic engineering

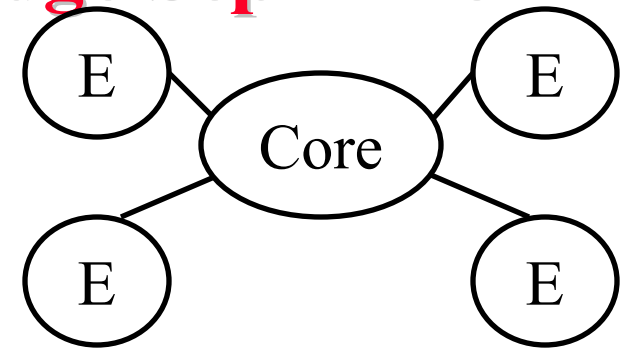

Refs: [LIT09, MEY07, RRG08]



LISP Protocol Details

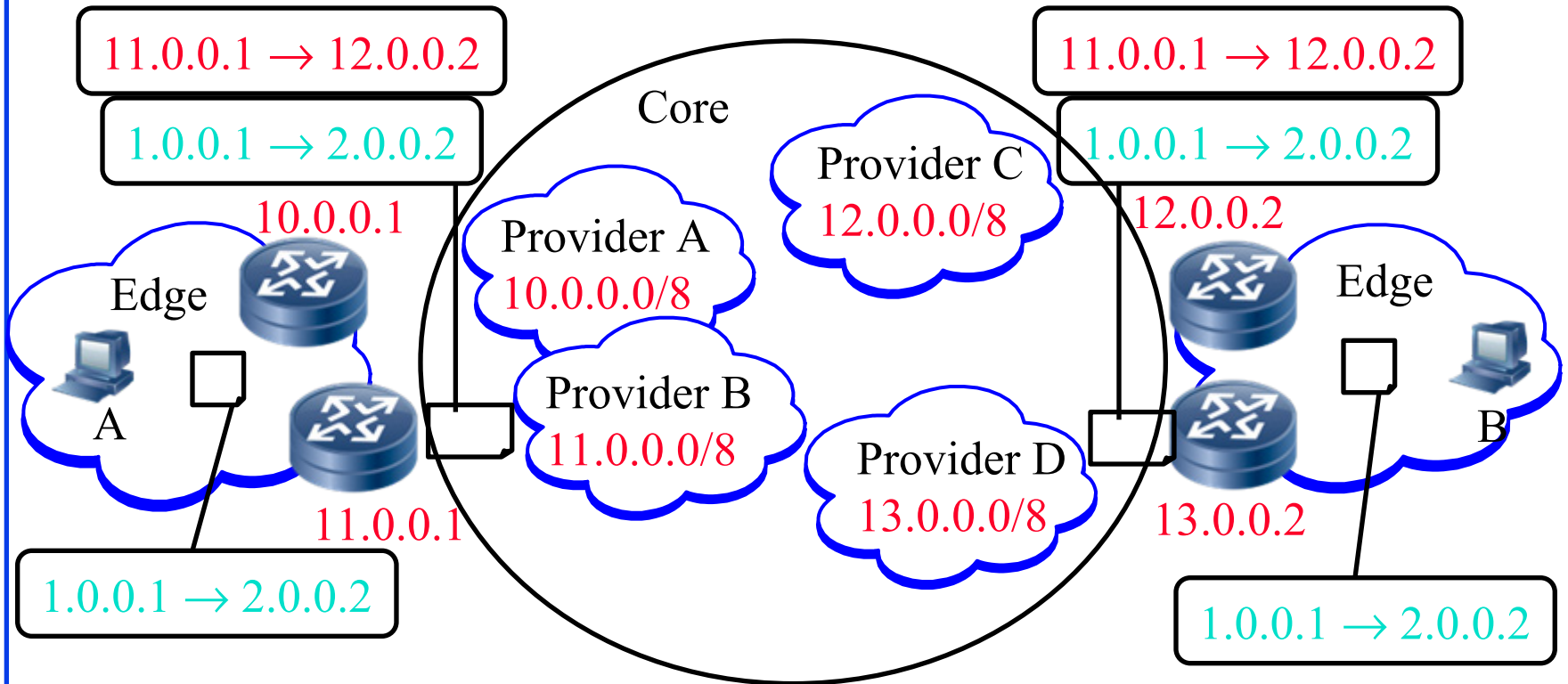

EIDs: Green
Locators: Red

DNS: B → 2.0.0.2

Mapping Entry:

EID-Prefix: 2.0.0.0/8

Locator Set:

12.0.0.2, priority 1, weight 50

13.0.0.2, priority 1, weight 50

Ref: www.nanog.org/meetings/nanog41/presentations/lisp-nanog-abq.pdf

MILSA

- ❑ Mobility and Multihoming Supporting ID-Locator Split Architecture
- ❑ New layer 3.5
- ❑ Distributed ID-locator mapping service
- ❑ New IDs = Secure Flat+Hierarchical
 - ⇒ No PI addresses in the global routing
- ❑ Proxy edge routers can translate IDs to locators
 - ⇒ Allows both router based and host based transition
- ❑ Incremental deployment

Refs: J. Pan, S. Paul, R. Jain, et al., "MILSA: A Mobility and Multihoming Supporting Identifier Locator Split Architecture for Next Generation Internet," GLOBECOM 2008, <http://www.cse.wustl.edu/~jain/papers/milsa.htm>



6. Next Generation Testbeds

- ❑ Past: PlanetLab, Emulab
- ❑ Federation
- ❑ GENI, Requirements, Subsystems
- ❑ GENI Prototype Clusters
- ❑ Supercharged PlanetLab Platform (SPP)
- ❑ FIRE
- ❑ AKARI

PlanetLab

- ❑ Global networking research testbed
- ❑ 1055 nodes at 490 sites [Nov 2009]
- ❑ Researchers use it to experiment with new ideas on distributed storage, network mapping, peer-to-peer systems, distributed hash tables, and query processing

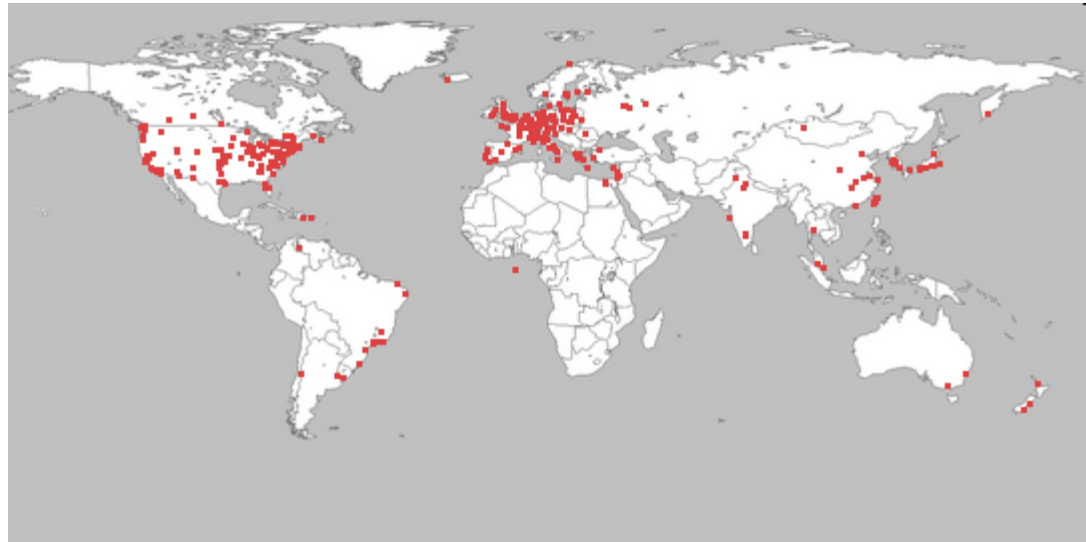

Ref: <http://www.planet-lab.org/>

PlanetLab (Cont)

- ❑ Linux virtual server software on Interneted nodes
- ❑ **Slivers** = Piece of a resource
- ❑ Node manager (**NM**) manages the node's virtual servers
- ❑ Planet Lab Control (**PLC**) interacts with NM
- ❑ Experimenters request a "**Slice**" = slivers in various sites

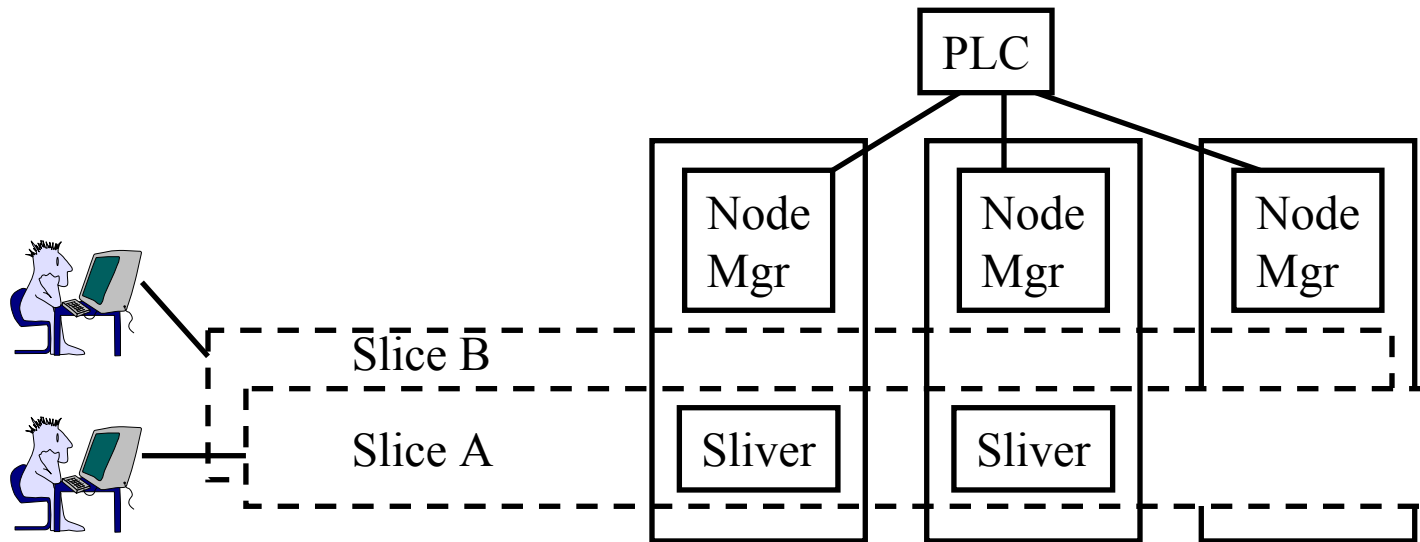

Emulab

- ❑ Networking research testbed at University of Utah
- ❑ Available for public use for research and education
- ❑ Software implemented at two dozen sites around the world
- ❑ Allows simulated links and nodes in slices
⇒ Allows fault studies
- ❑ Provides repeatability



[emulab.net]

Ref: <http://www.emulab.net/>

Federation

- ❑ Larger testbeds
- ❑ Testbeds for specialized resources such as access technologies
- ❑ Specialized research communities and cross-discipline
- ❑ Challenges:
 - Homogenization of diverse context
 - Interoperability of security protocols
 - Political or social-economic issues
 - Intellectual Property rights
 - Commercial and non-commercial interests

Ref: OneLab2 Whitepaper: ``On Federations..., January 2009,
<http://www.onelab.eu/index.php/results/whitepapers/294-whitepaper-1-on-federations.html>

GENI

- ❑ Global Environment for Network Innovations
- ❑ Dedicated shared substrate facility for large-scale experiments
- ❑ US National Science Foundation project
- ❑ Dedicated backbone links through LambdaRail and Internet2
- ❑ Diverse and extensible set of technologies

Refs: [GENI01, ON410]

GENI Requirements

- ❑ Sliceability: Sharing with isolation.
- ❑ Programmability: All components should be programmable
- ❑ Virtualization: Slicing via virtualization or space/time sharing.
- ❑ Federation: Combination of independently owned testbeds
- ❑ Observability: Allow specifiable measurement framework
- ❑ Security: Should not harm production Internet

Refs: [AND052, SHA05, CLA05, RAY05, BLU05, BELL05, KAA05]

GENI Subsystems

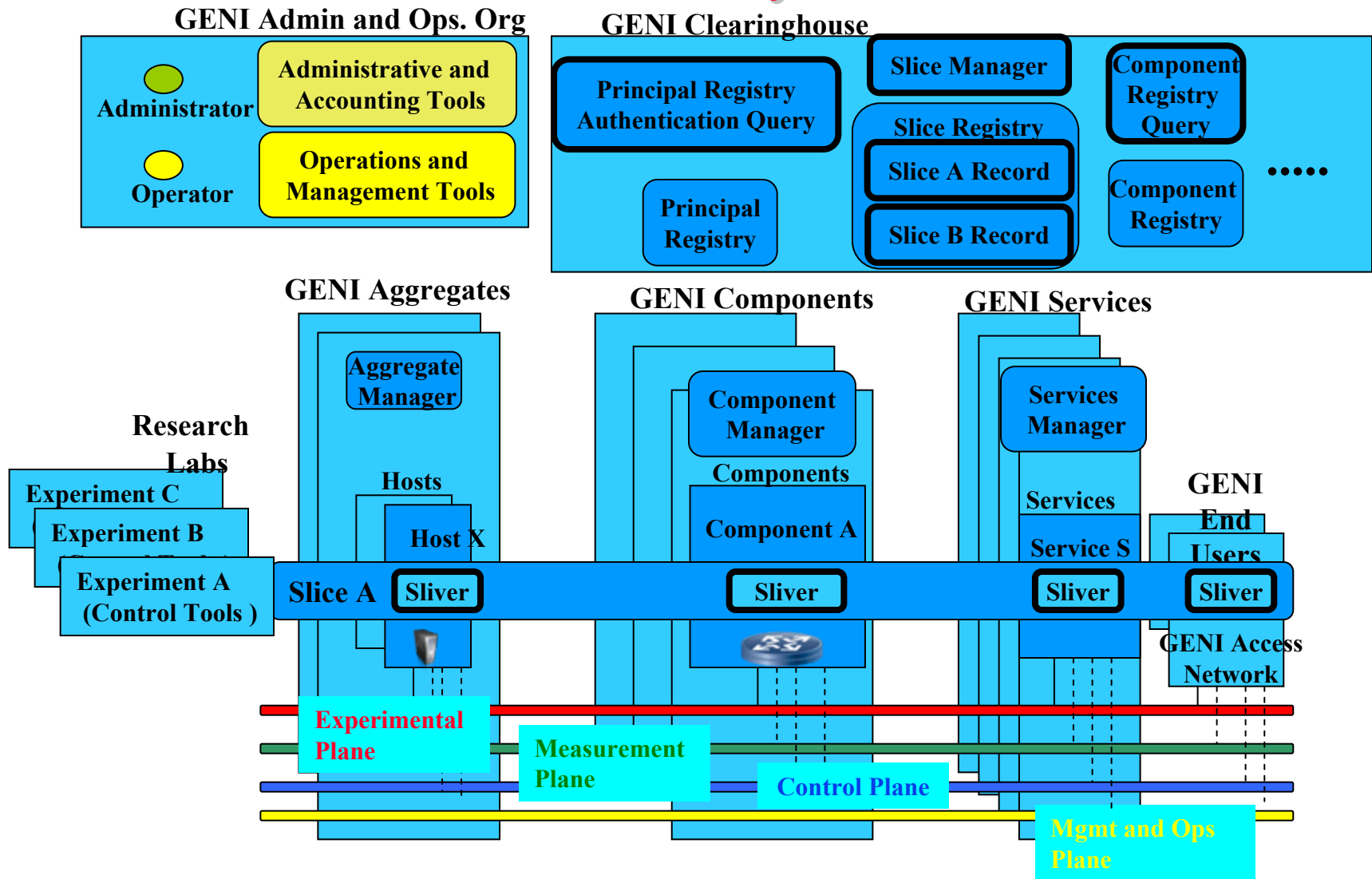

GENI Prototype Clusters

Five Clusters in Spiral 1:

1. Trial Integration Environment with DETER (TIAD):
Emulab based security experiments testbed
 2. PlanetLab: Federate all slice-based substrates PlanetLab, Emulab, VINI, and GENI
 3. ProtoGENI: Federation of Emulab testbeds,
Enhanced Emulab Control
 4. Open Resource Control Architecture (ORCA):
Resource manager runs under the host operating system
Uses virtualization to allocate containers
 5. Open Access Research Testbed (ORBIT): Wireless testbed
with emulated and real nodes
- Spiral 2: Improved instrumentation, tools for integration
 - Spiral 3: Integration. Experimentation across clusters.

Ref: GENI Spiral 1, <http://groups.geni.net/geni/wiki/>

Virtualizable Network Concept

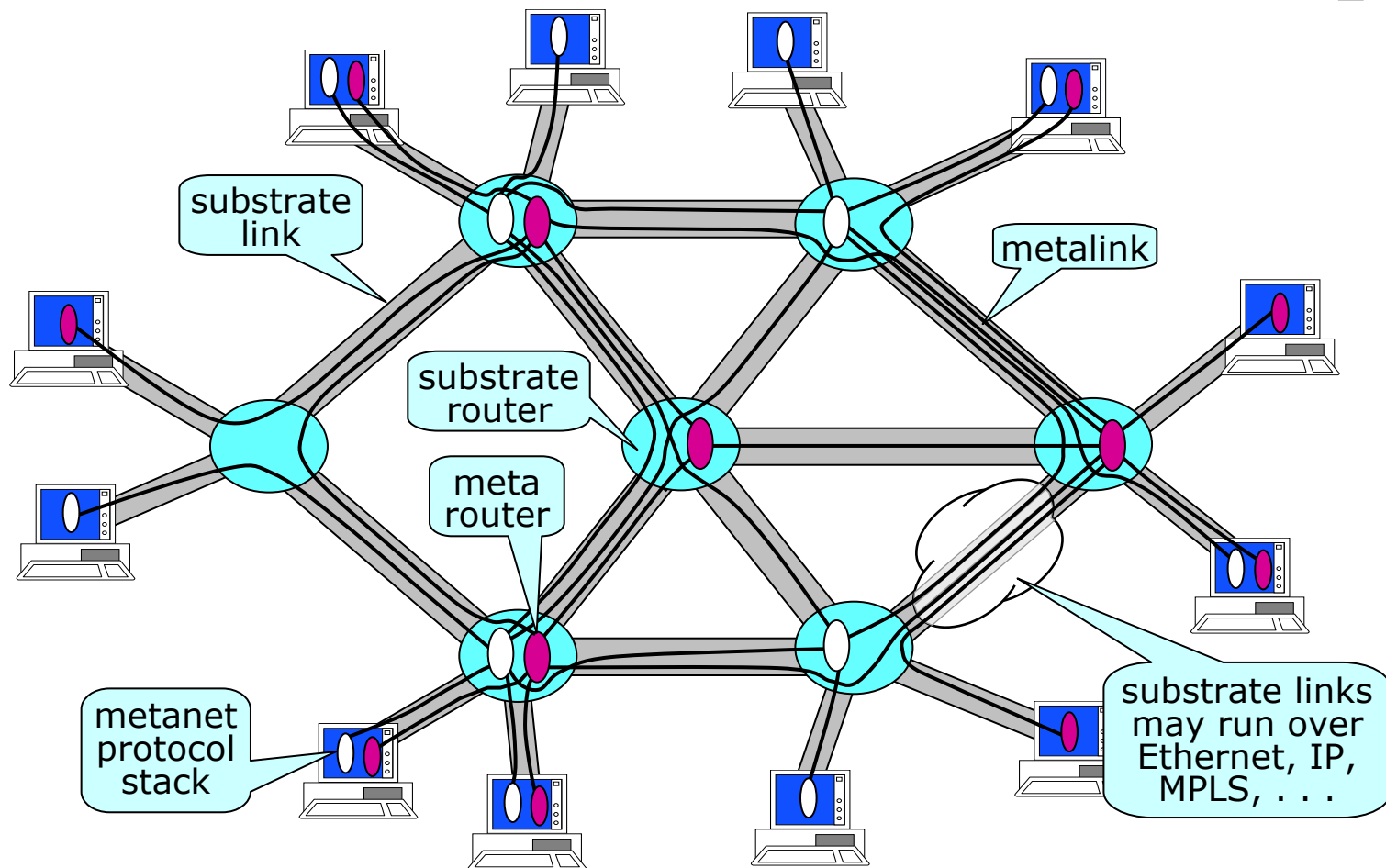

Ref: T. Anderson, L. Peterson, S. Shenker, J. Turner, "Overcoming the Internet Impasse through Virtualization," *Computer*, April 2005, pp. 34 – 41.

Slide taken from Jon Turner's presentation at Cisco Routing Research Symposium

Virtualization

- ❑ Allows multiple overlays on a single substrate
- ❑ Allows nodes to treat an overlay as a native network
- ❑ Provides isolation \Rightarrow multiple architectures, Partitioned Control
- ❑ Allow testing diverse routing protocols and service paradigms
- ❑ Better architectures will attract more users and become main line
- ❑ Allows diversified services while utilizing economies of scale in the substrate components
- ❑ Virtualization over IP networks
 \Rightarrow Not suitable for experiments at lower layers

Ref: T. Anderson, L. Peterson, S. Shenker, J. Turner, "Overcoming the Internet Impasse through Virtualization," Computer, Volume 38, Issue 4, pp 34-41, April 2005.

Supercharged PlanetLab Platform (SPP)

- ❑ Allows multiple virtual routers w different stacks
- ❑ Fast path for line speed packet forwarding
- ❑ Slow path for application specific processing
- ❑ Multiple meta-networks (routers, links) on a substrate
- ❑ 3 Components: Line cards, switching fabric, control proc
- ❑ Virtualizing line cards is difficult
- ❑ Processing Pool Architecture:
No processing in line cards
Simply switch to proc engines

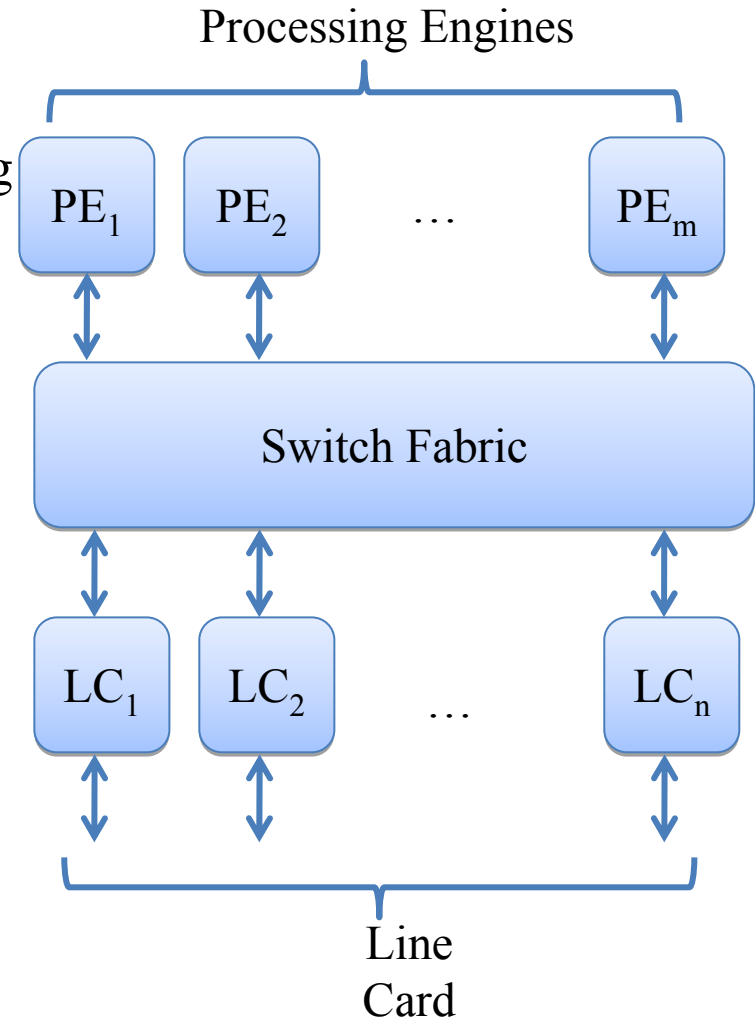

Refs: [TUR06, TUR107, TUR207]

FP7/ICT Program 2011/12

Challenge 1 - "Pervasive and Trusted Network and Service Infrastructures"

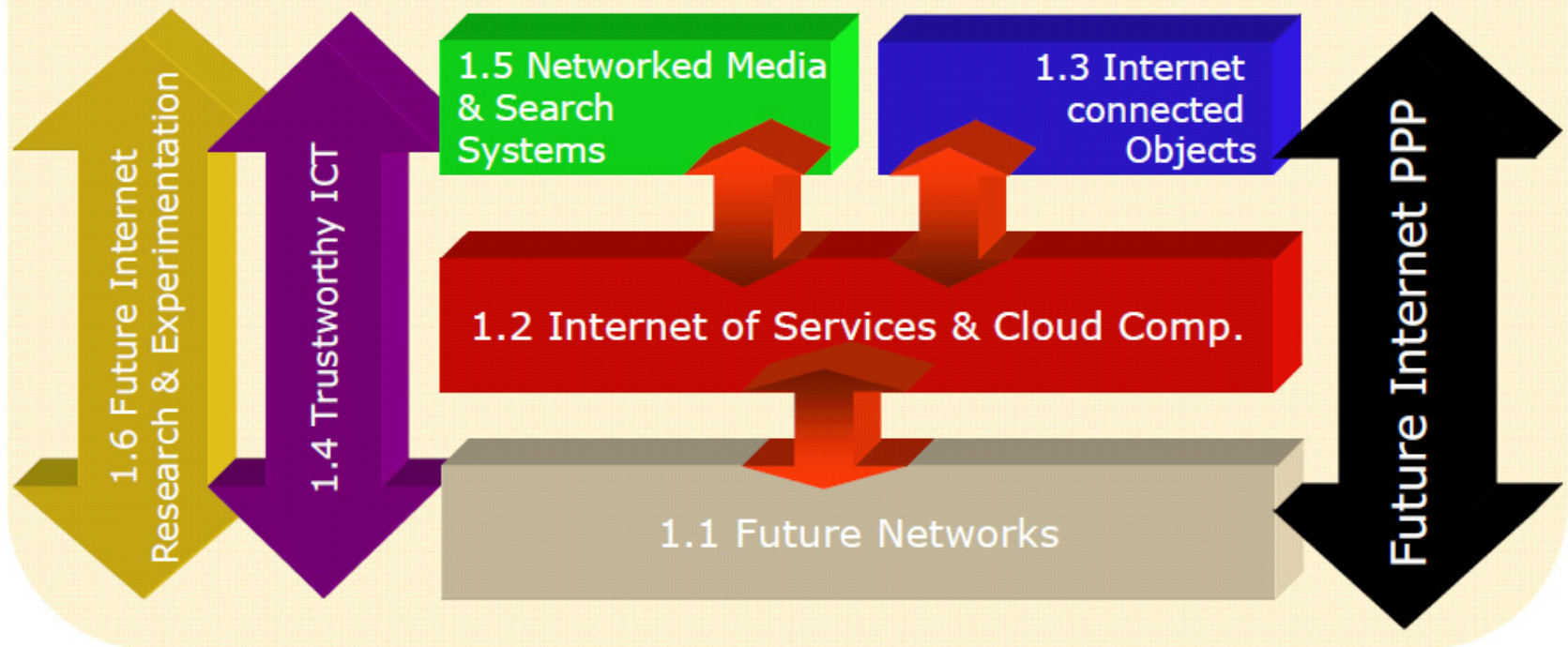

Ref: European Framework Programme for Research and Innovation (FP7),

http://ec.europa.eu/information_society/activities/foi/research/eu-japan/eujapan3/docs/fatelnig.pdf

Washington University in St. Louis

<http://www1.cse.wustl.edu/~jain/tutorials/icc11.htm>

©2011 Raj Jain

FIRE

- ❑ Future Internet Research and Experimentation
- ❑ Federate multiple existing testbeds in Europe
⇒ Provide a large multi-context research testbed

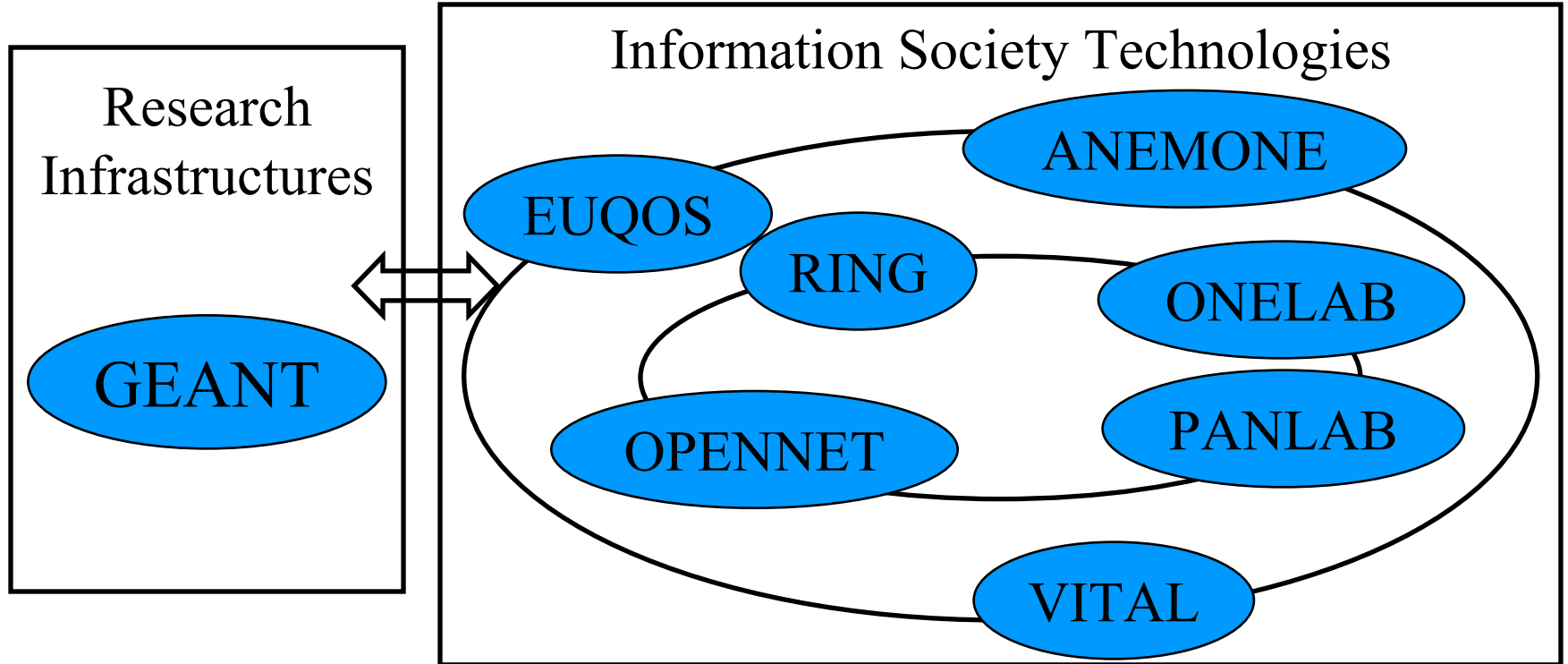

Japan

- ❑ Next Generation (Incremental): NXGN
 - Add QoS and authentication to IP
- ❑ New Generation (Clean slate): NWGN for 2015+
 1. National Institute for Information and Communications Technology (NiCT) is leading the research on NWGN
 - AKARI= A Small light pointing to the future
 2. Testbeds:
 - JGN2plus testbed for Network Virtualization
 - JGN X testbed for NWGN services and operations
 3. NWGN Promotion Forum (Japan Wide, Industry and Academic)

Ref: <http://akar-project.nict.go.jp>

AKARI Components

1. Parallel Optical Packet Transmission
2. All-Optical path/packet switching
3. Packet division multiple access
4. ID/Locator separation
5. Overlay network/Virtualization
6. Self-Organizing control

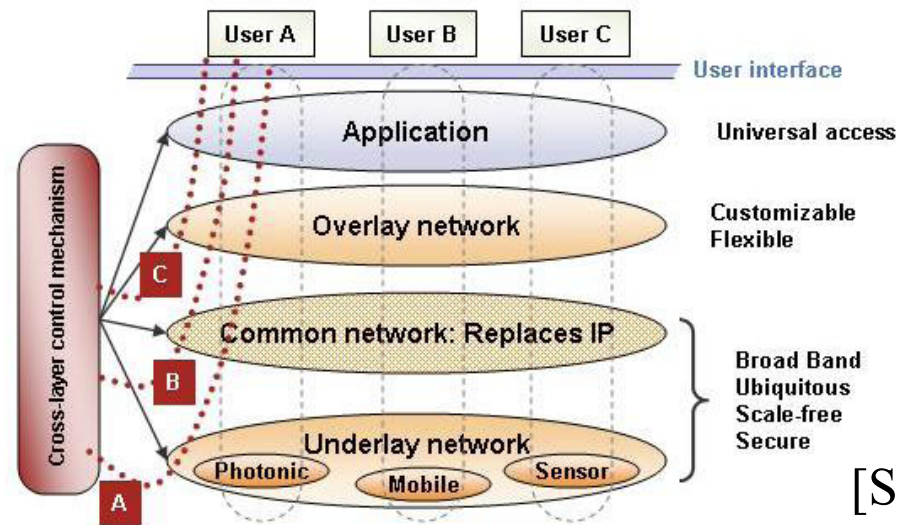

[Source: AKARI]

Ref: "AKARI Architecture Conceptual Design", <http://akari-project.nict.go.jp/eng/conceptdesign.htm>

Top 10 Features of Next Generation Internet

1. Security
2. Mobility
3. User/Data-Centric: Network support of data objects
4. Easy to use: Self-organizing, better user control
5. Disruption Tolerant
6. Green: Proxy, Sleep Modes,
7. Services: Storage, Translation, Monitoring
8. Organizational Representation
9. Virtualizable to create Application Specific Context
10. Policy Enforcement

NSF FIA Winners

- ❑ **Named Data Networking:** CCN
 - Routing scalability, Fast forwarding, Trust models, Network security, Content protection and privacy
- ❑ **Mobility First:** Generalized Delay Tolerant Networking with self-certifying public key addresses
- ❑ **Nebula** (Latin for Cloud): Trustworthy data, control and core networking for cloud computing
- ❑ **eXpressive Internet Architecture (XIA):** Application programming interface (API) for communication, flexible context-dependent mechanisms for establishing trust

Ref: NSF Announces Future Internet Architecture Awards, August 27, 2010,
http://www.nsf.gov/news/news_summ.jsp?cntn_id=117611

Washington University in St. Louis <http://www1.cse.wustl.edu/~jain/tutorials/icc11.htm>

©2011 Raj Jain

XIA

- ❑ Partners: CMU, BU, UWisc
- ❑ Security, x-centric
- ❑ Principals: Hosts, Domain, Contents, Services, Users
- ❑ Secure identifiers for all principals: Hash of the public key
- ❑ Content naming based on cryptographic hash of the content
⇒ Receiver can verify correct content

Ref: A. Anand, et al, "XIA:An Architecture for an Evolvable and Trustworthy Internet,"

<http://reports-archive.adm.cs.cmu.edu/anon/2011/CMU-CS-11-100.pdf>

Washington University in St. Louis

<http://www1.cse.wustl.edu/~jain/tutorials/icc11.htm>

©2011 Raj Jain

eXpressive Internet Protocol (XIP)

- ❑ Allows multiple destinations
- ❑ Allows multiple paths to a destination
- ❑ XIP addresses are directed acyclic graphs (DAGs)

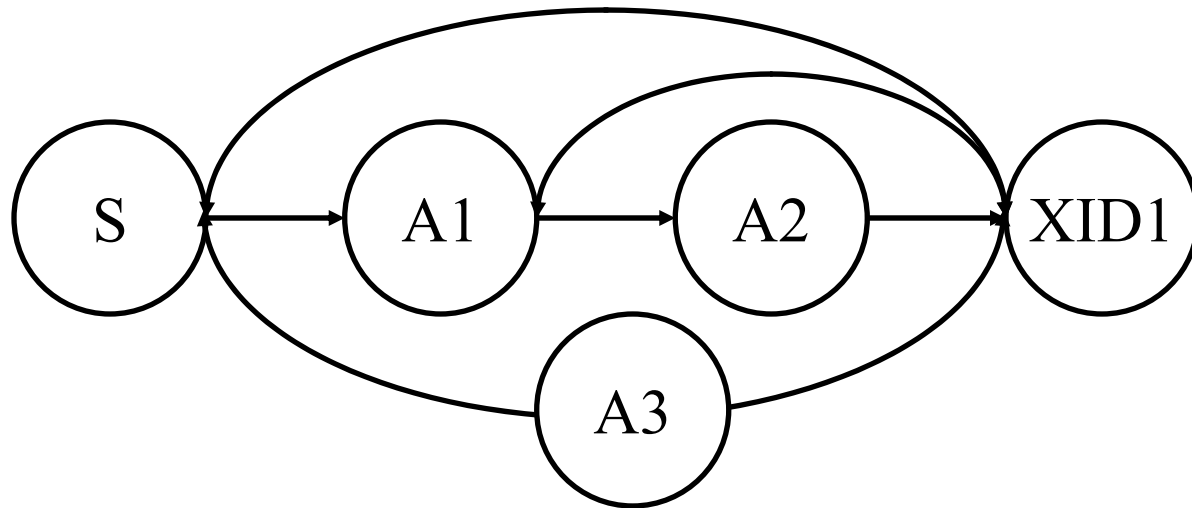

XIP Packet Header

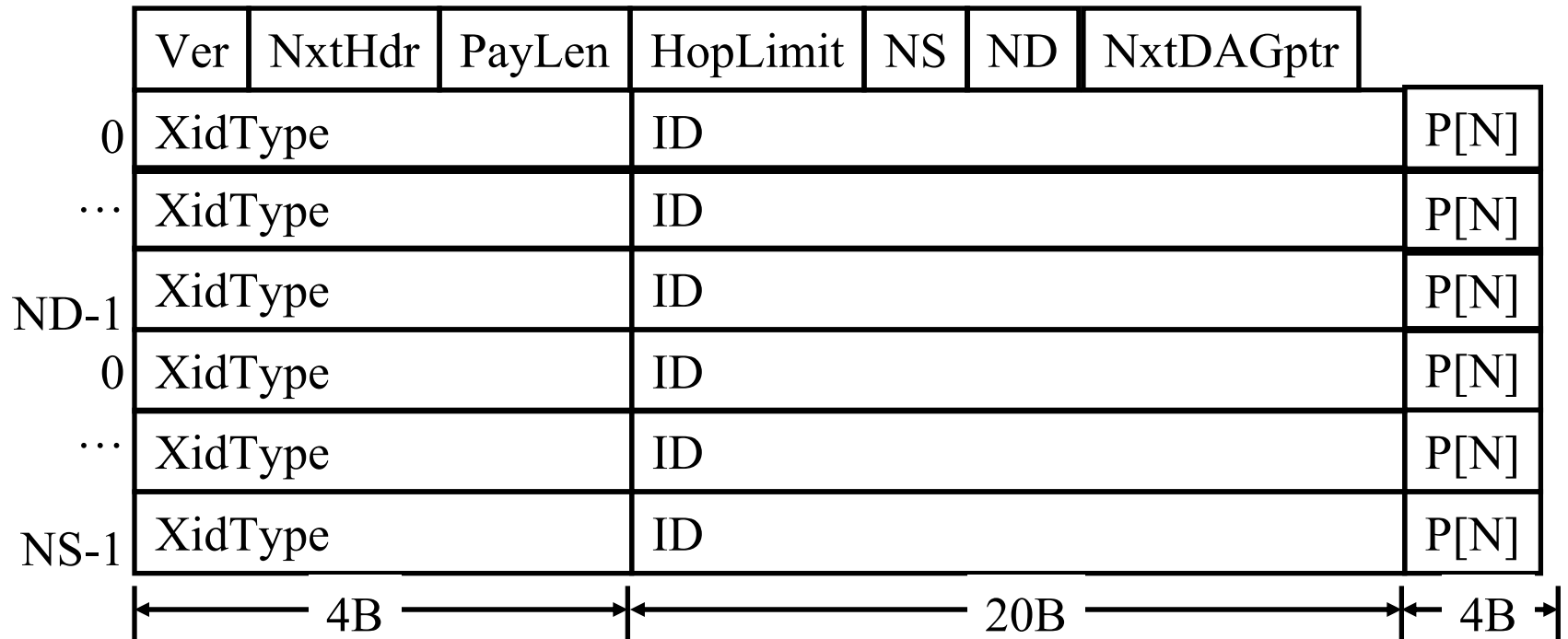

- ❑ Variable length DAG fields
- ❑ 28B per DAG (4B type, 20B address, 4 1B edge pointers)

XIP Transfer Example

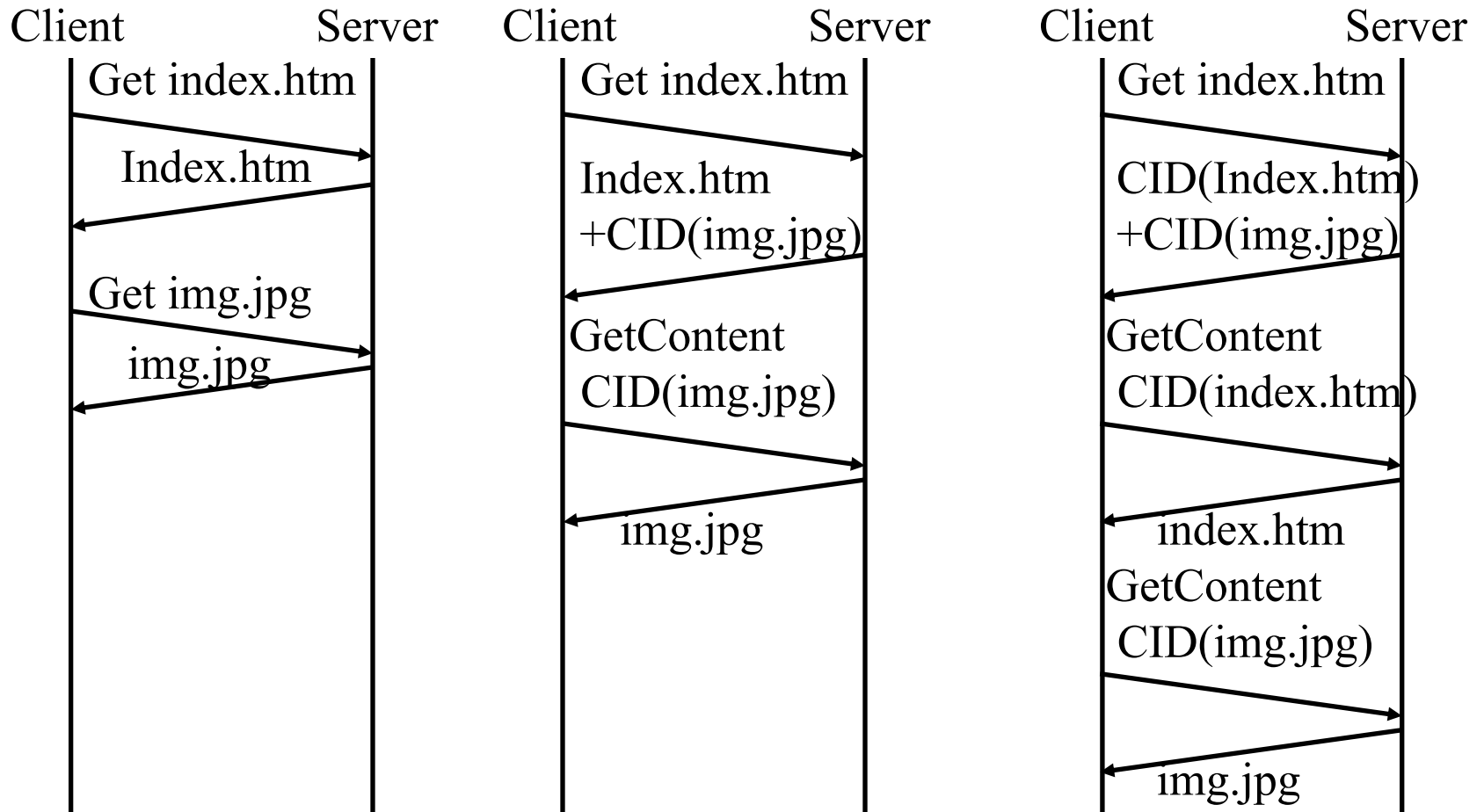

- With CID, clients can get the content from other servers, replicas, and caches

Services on XIA

- ❑ Services are identified as: $AD_{ID}:Host_{ID}:Service_{ID}$
- ❑ Resolvers may resolve the $Service_{ID}$ to $AD_{ID}:Service_{ID}$ (Host is not specified)
- ❑ AD can select any host with that service
 $\Rightarrow AD_{ID}:Host_{ID}:Service_{ID}$
- ❑ If the service moves, new client is notified of the new hostID via a signed message from the previous host

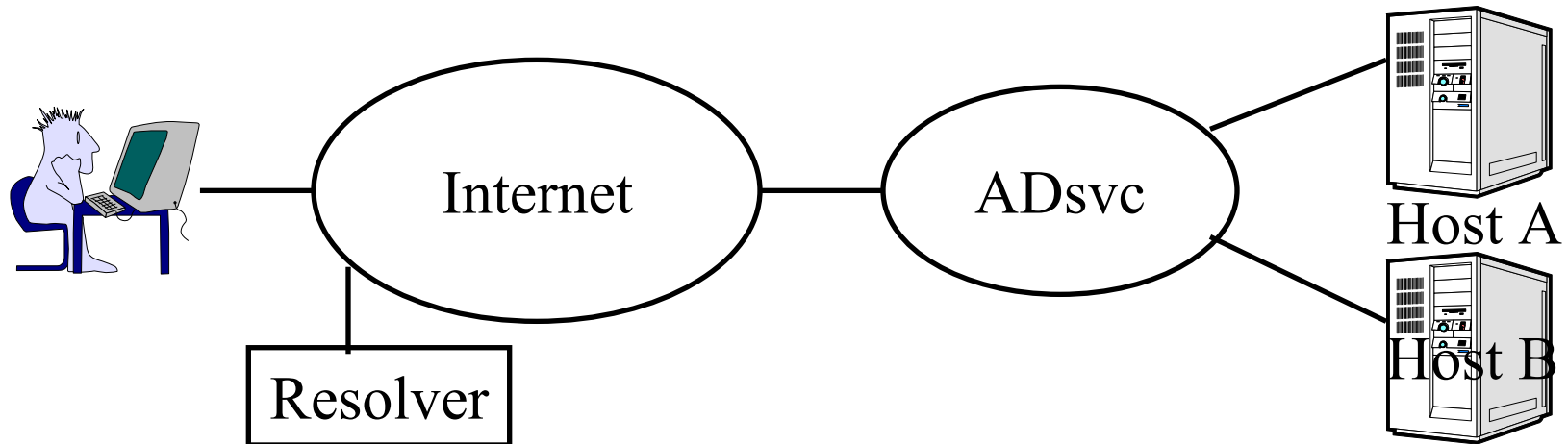

MobilityFirst

- ❑ Partners: Rutgers, UMass, Duke, UMichigan, UNC, MIT, UNebraska, UWisconsin
- ❑ Designed for mobile devices: 4B cell phones
 1. Separation of naming and addressing
 2. Self-certifying public key network addresses
 3. Generalized Delay-tolerant networking
 4. Hop-by-hop transport protocol over path segments
 5. Flat-label internet routing with public key addresses
 6. Separate network management plane
 7. Privacy features for user and location data
 8. Programmability of routers for evolution

Ref: <http://mobilityfirst.winlab.rutgers.edu/>

NEBULA

- ❑ Trustworthy cloud computing
 - ❑ Multiple stakeholders: Sender, receiver, transit providers, middle boxes, ... Each has its own policy
 - ❑ A packet is forwarded if the path meets all policies
1. Nebula Control Plane (NVENT): policy negotiation. Generates Proof of Consent (PoC) – Route authorized
 2. Nebula Data plane (NDP): Uses PoC and generates Proof of Path (PoP) – Route followed
 3. Nebula Core (NCORE): Provides high availability paths

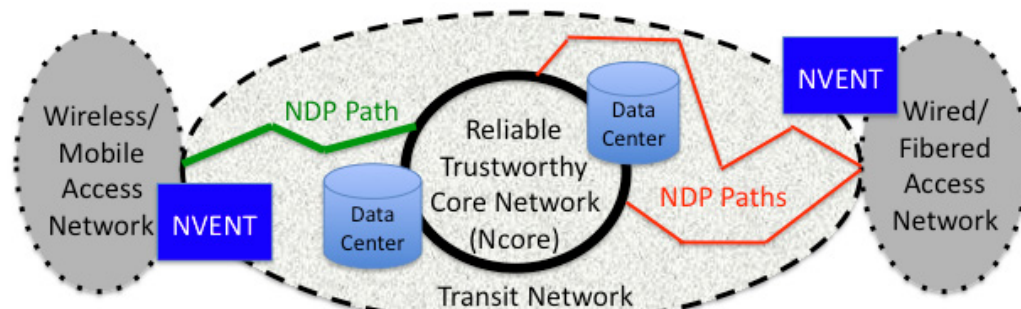

Ref: http://nebula.cis.upenn.edu/NEBULA_brief.pdf

Washington University in St. Louis

<http://www1.cse.wustl.edu/~jain/tutorials/icc11.htm>

©2011 Raj Jain

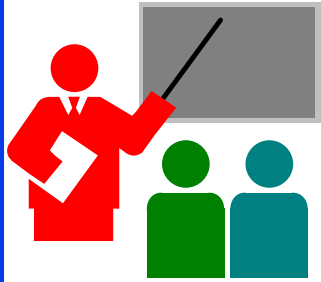

Summary: NGI Research

- Clean-slate Internet architecture program started with NSF FIND program in 2005. Now extensive research in Europe, Japan, China, Korea, Taiwan, ...

	USA	Europe	Japan
Architecture	1. FIND 40+ projects 2. FIA a. NDN b. XIA c. MobilityFirst d. Nebula	FP7: 1. Network of the future 2. Service and software architectures, Infrastructures and Engineering 3. Secure, Dependable and Trusted Infrastructure 4. Networked Media	AKARI
Testbed	GENI	GEANT2 (34 NRENs) FIRE	JGN2, JGN2plus, JGN2 X

Thank You!

